

CINCH PART NUMBER MATRIX

P/N: 581 01 48 005

P/N: 581 01 48 007

48-WAY HEADER ASSEMBLY WITH OUT FERRITE FILTERS

48-WAY HEADER ASSEMBLY WITH FERRITE FILTERS

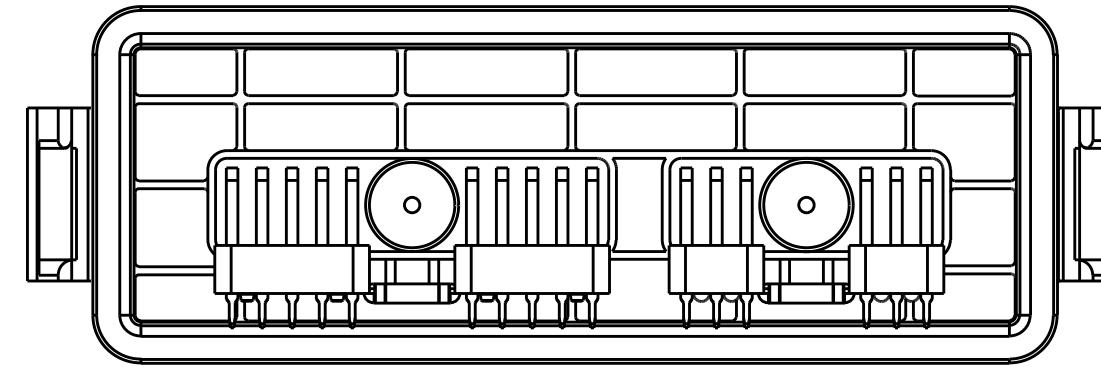
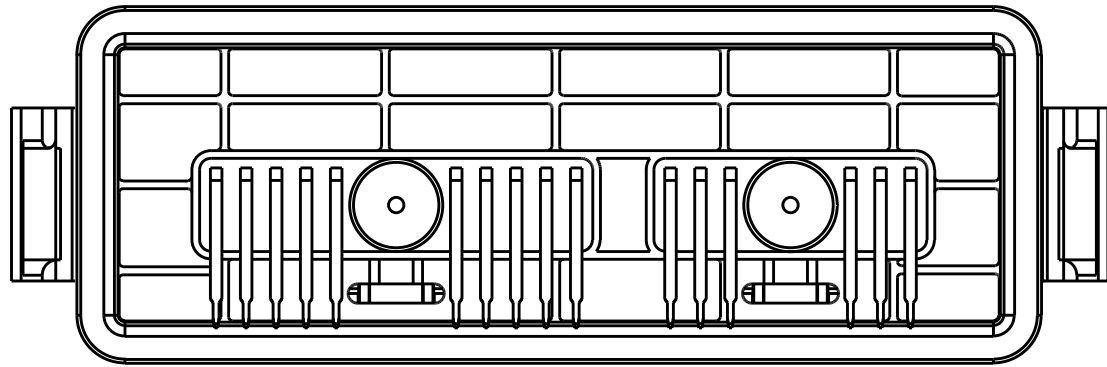
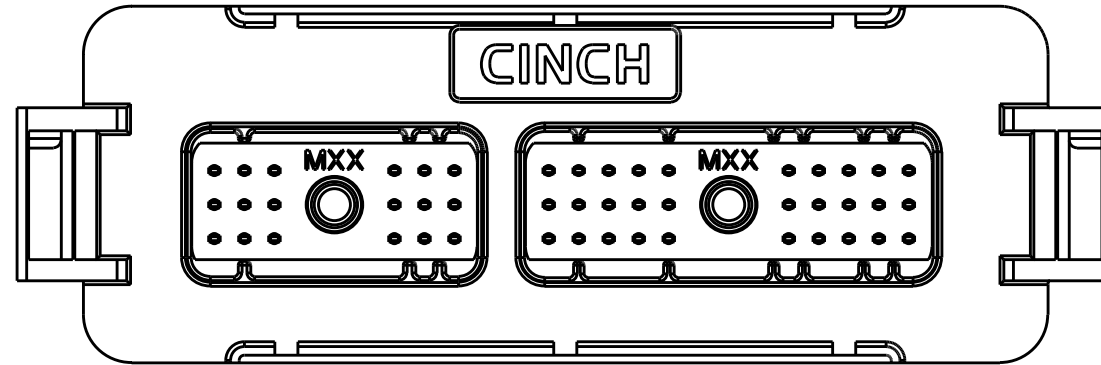
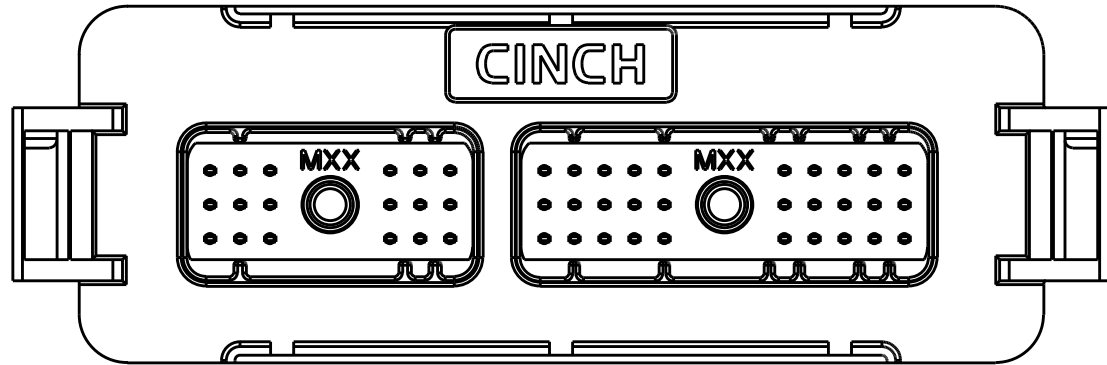

MATES WITH CINCH HARNESS CONNECTORS P/N:
581 01 18 023 (18-WAY) AND 581 01 30 029 (30-WAY)

DRAWING REVISIONS

REV	DOCUMENT	APP	DATE
A	REL. FOR PRODUCTION D.O. 05-1157	A.C.	7/21/05
B	ECN: 05A468 ADDED LEGS AND ADDED SLOTS TO RIBS	A.C.	9/27/05
C	ECN: 06A635 ADDED SHEET 5 ADDED SHEET 6 MODIFIED SHEET 3 MODIFIED SHEET 4	A.C.	3/24/06
D	ECN: 06A408 REFORMATTED DRAWING PCB LAYOUTS REDRAWN WITH ADDITIONAL KEEP OUT AREAS	A.C.	9/28/06
E	CO 4256	N.C.	3/31/20

NOTES:

- ALL DIMENSIONS ARE IN INCHES;
DIMENSION INSIDE [.XX] ARE IN MM, AS REF. ONLY.
- MATERIALS:
INTERFACE SEAL: SILICONE RUBBER, COLOR BLUE;
INSULATOR: 30 % GLASS FILLED POLYMER, COLOR BLACK;
BUSHING: BRASS ALLOY, UNPLATED 10-24 UNC THREAD;
TERMINAL BLADE: 1.5 MM BRASS WITH TIN OVER NICKEL PLATING;
FILTERS: FERRITE BLOCKS.
- ALL HEADERS ARE REFLOW OR WAVE SOLDERING PROCESS, ROHS COMPLIANT.
- MATES WITH CINCH SHS PUSH-TO-SEAT HARNESS CONNECTORS (SEE TABLE ABOVE).
- THERMALLY CONDUCTIVE ADHESIVE PASTE SOLD SEPARATLY: RECOMMENDED IS LOCTITE 383.
- MOSFET SPRING PLATES ARE SOLD SEPARATLY (FOR INSTALLATION REFER TO ENCLOSURE ASSEMBLY INSTRUCTIONS) SPRING LABELED AS "L" IS CINCH P/N: 581 00 00 020 AND SPRING LABELED AS "R" IS CINCH P/N: 581 00 00 021.
(IT IS RECOMMENDED THAT THE 4 SLOTS BE PROTECTED DURING CONFORMAL COATING)
- STANDARD PACKAGE SIZE: 72 PARTS/CARTON BOX.

UNITS		RoHS COMPLIANT		MODELED BY:	
ENGLISH	INCHES	PRO/E		CINCH	
DO NOT SCALE DRAWING		DESIGN BY	DATE	TITLE	
UNLESS OTHERWISE SPECIFIED: ALL DIMENSIONS ARE IN INCHES		B. KOSTIC	09/03/04	SE HEADERS MODULAR ICE	
FILLET/RADII .02 MAX	TOLERANCES .X ± .1 .XX ± .01 .XXX ± .005 ANGULAR ± .5°	DESIGN ENGINEER		MATERIAL	CONTROL SPEC NUMBER
		B. KOSTIC	09/03/04	SEE NOTE 2.	
		DESIGN ENGINEERING MGR.		MATERIAL SPEC NUMBER	PROJECT NUMBER
		A. CAINES	11/18/04	A 14562	
THIS DOCUMENT IS THE PROPERTY OF CINCH. NEITHER THIS DOCUMENT NOR ANY OF THE INFORMATION CONTAINED IN IT MAY BE DUPLICATED OR DISCLOSED WITHOUT PRIOR WRITTEN CONSENT OF CINCH.		MFG. ENGINEERING		CAD FILE NUMBER	DRAWING NUMBER
		R. GARZA	11/18/04	5810148005S	581 01 48 005 S
		QUALITY ASSURANCE		CAGE IDENT NO.	SCALE
		R. QUIROZ	11/18/04	71785	B 1:1
				SIZE	SHEET 1 OF 6

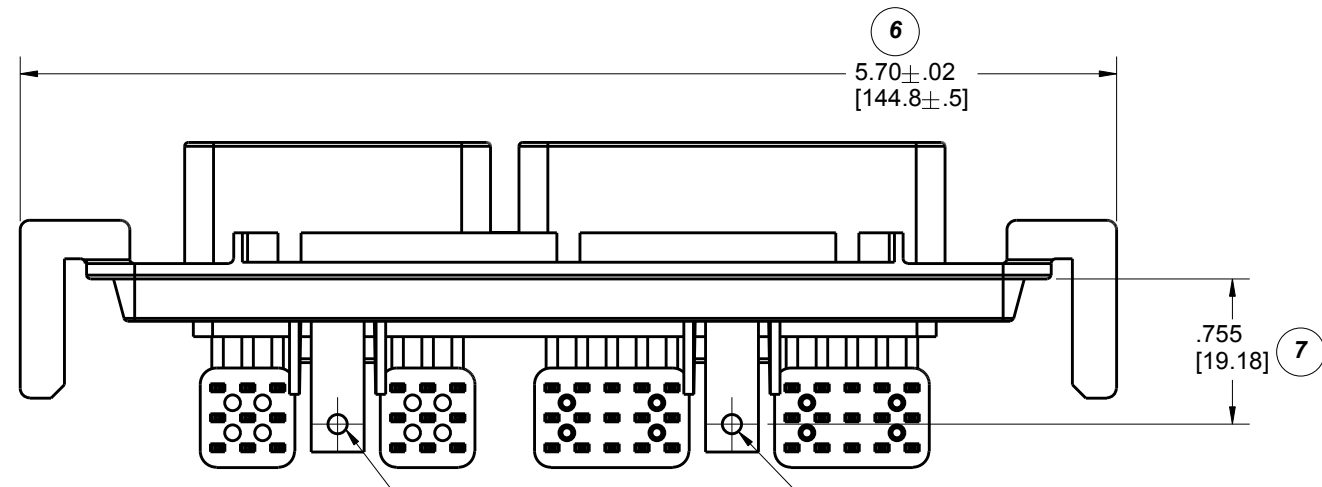
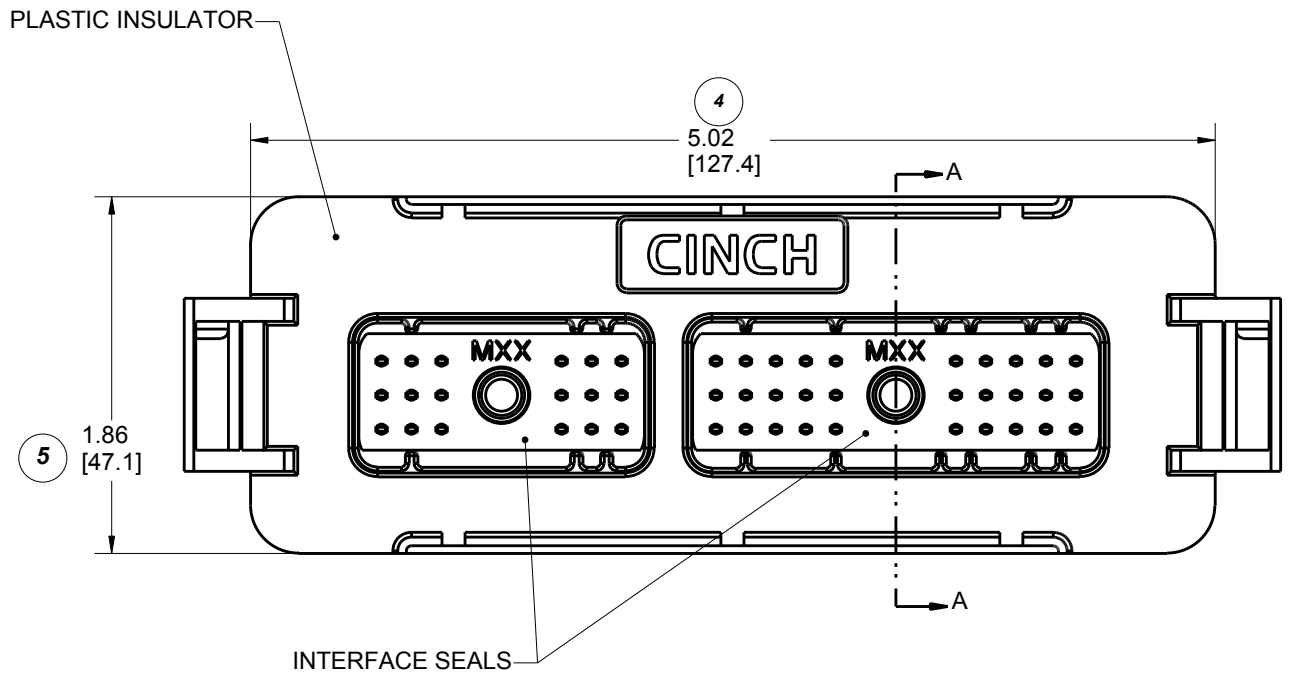
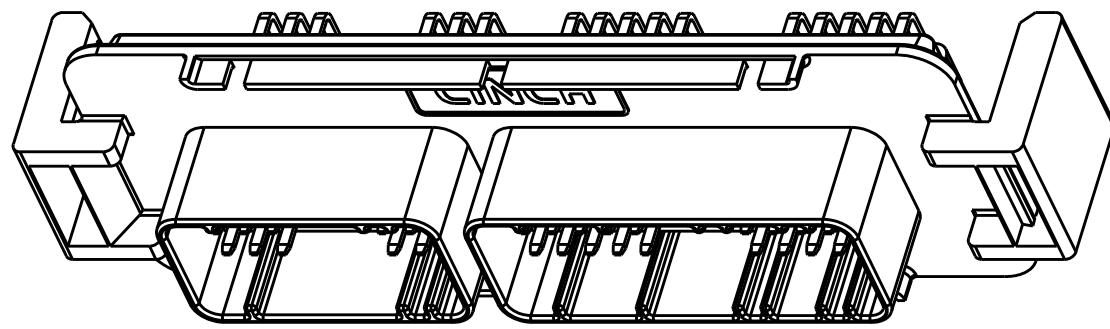
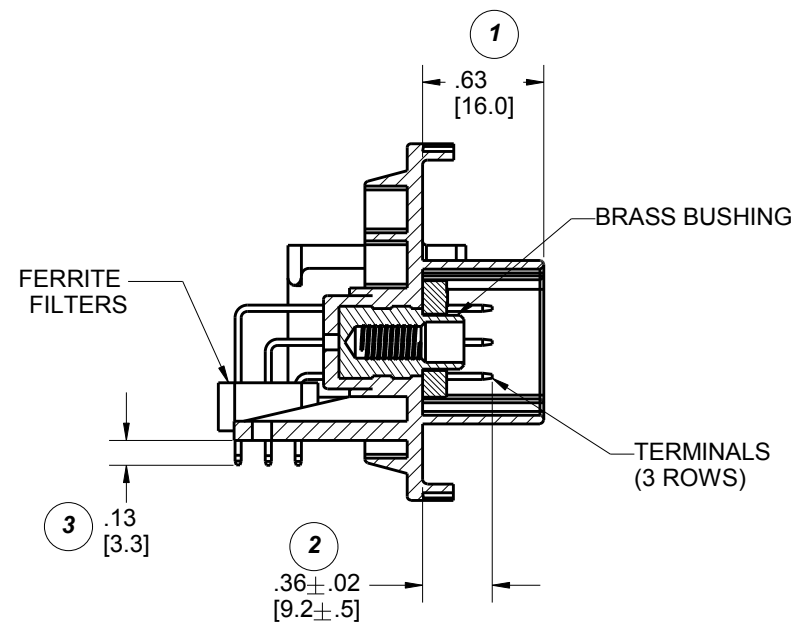

FOR PCB MOUNTING #4 SELF-TAPPING SCREW IS RECOMMENDED TORQUE: 2-3 IN*LB. [0.23-0.34 Nm]

CINCH P/N: 581 01 48 007 SHOWN (HEADER WITH FILTERS)

UNITS ENGLISH		CINCH		1700 FINLEY RD LOMBARD, IL. 60148	
DO NOT SCALE DRAWING		TITLE SE HEADERS MODULAR ICE			
UNLESS OTHERWISE SPECIFIED: ALL DIMENSIONS ARE IN INCHES		PRO/E DRAWING			
FILLET/RADII .02 MAX		TOLERANCES X ± .1 XX ± .01 XXX ± .005 ANGULAR ± .5°		CAD FILE NUMBER 5810148005S	DRAWING NUMBER 581 01 48 005 S
TOLERANCES AND LIMITS APPLY OVER ADDITIVE FINISH		CAGE IDENT NO. 71785	SIZE B	SCALE 1:1	REV E
THIS DOCUMENT IS THE PROPERTY OF CINCH. NEITHER THIS DOCUMENT NOR ANY OF THE INFORMATION CONTAINED IN IT MAY BE DUPLICATED OR DISCLOSED WITHOUT PRIOR WRITTEN CONSENT OF CINCH.		SHEET 2 OF 6			

PCB LAYOUT WITHOUT HEAT SINKS

PCB TOP SIDE GENERAL ZONING & KEEP OUT AREAS

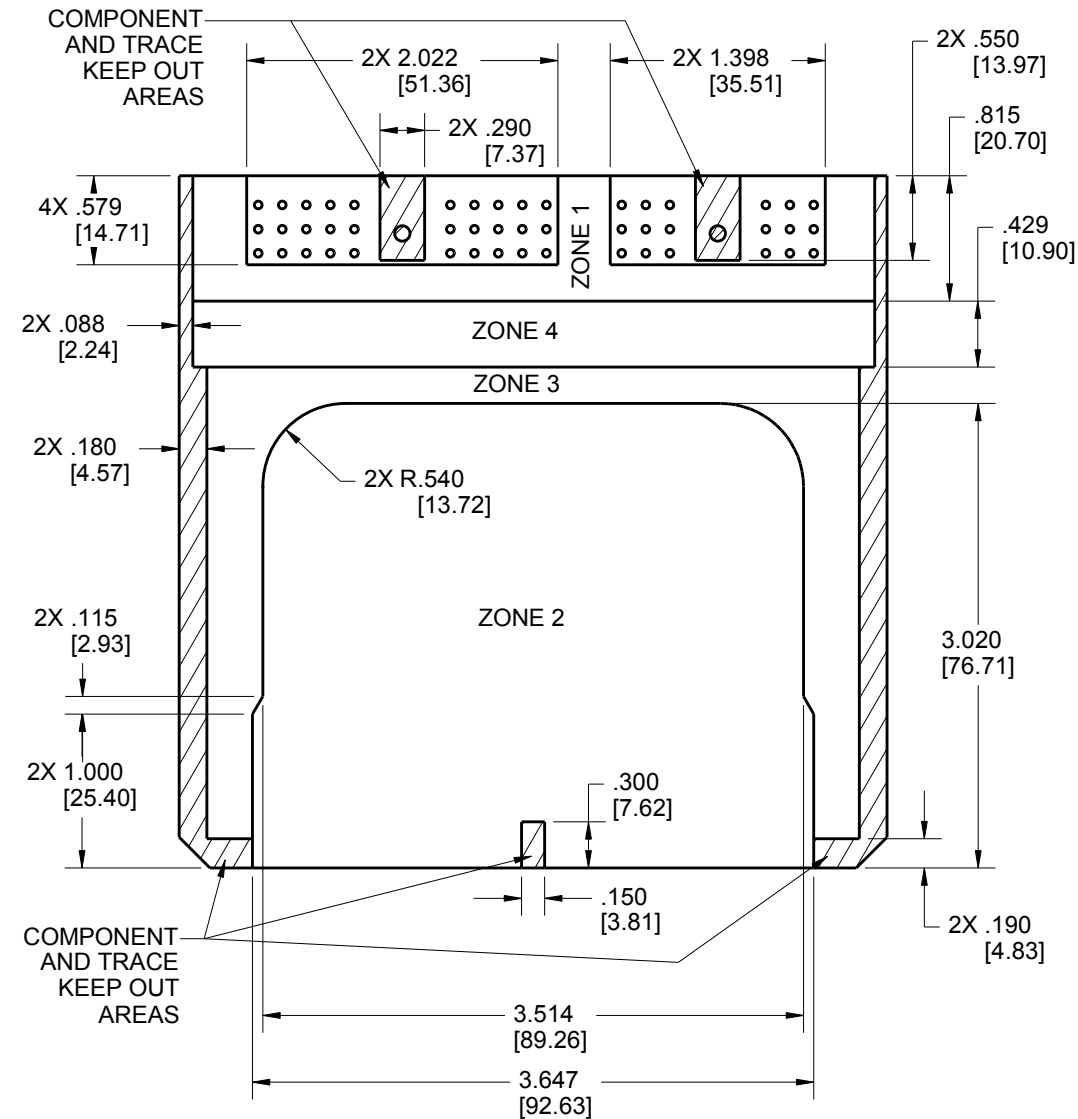

PCB BOTTOM SIDE GENERAL ZONING & KEEP OUT AREAS

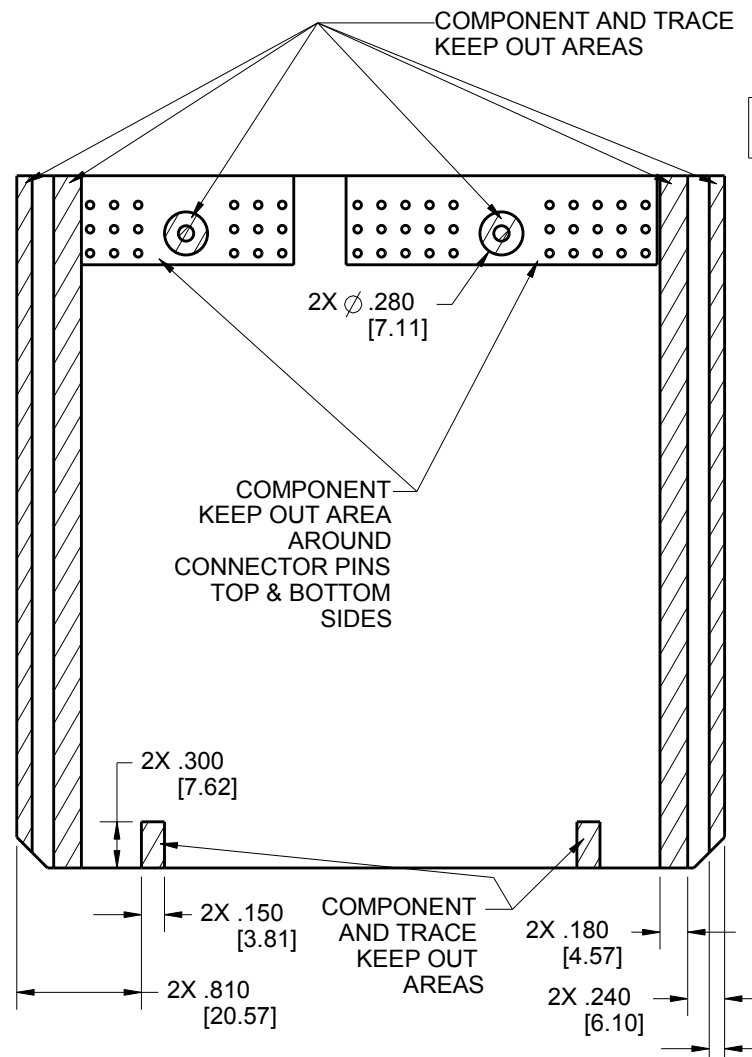

PCB OVERALL DIMENSIONS AND HOLE LOCATIONS

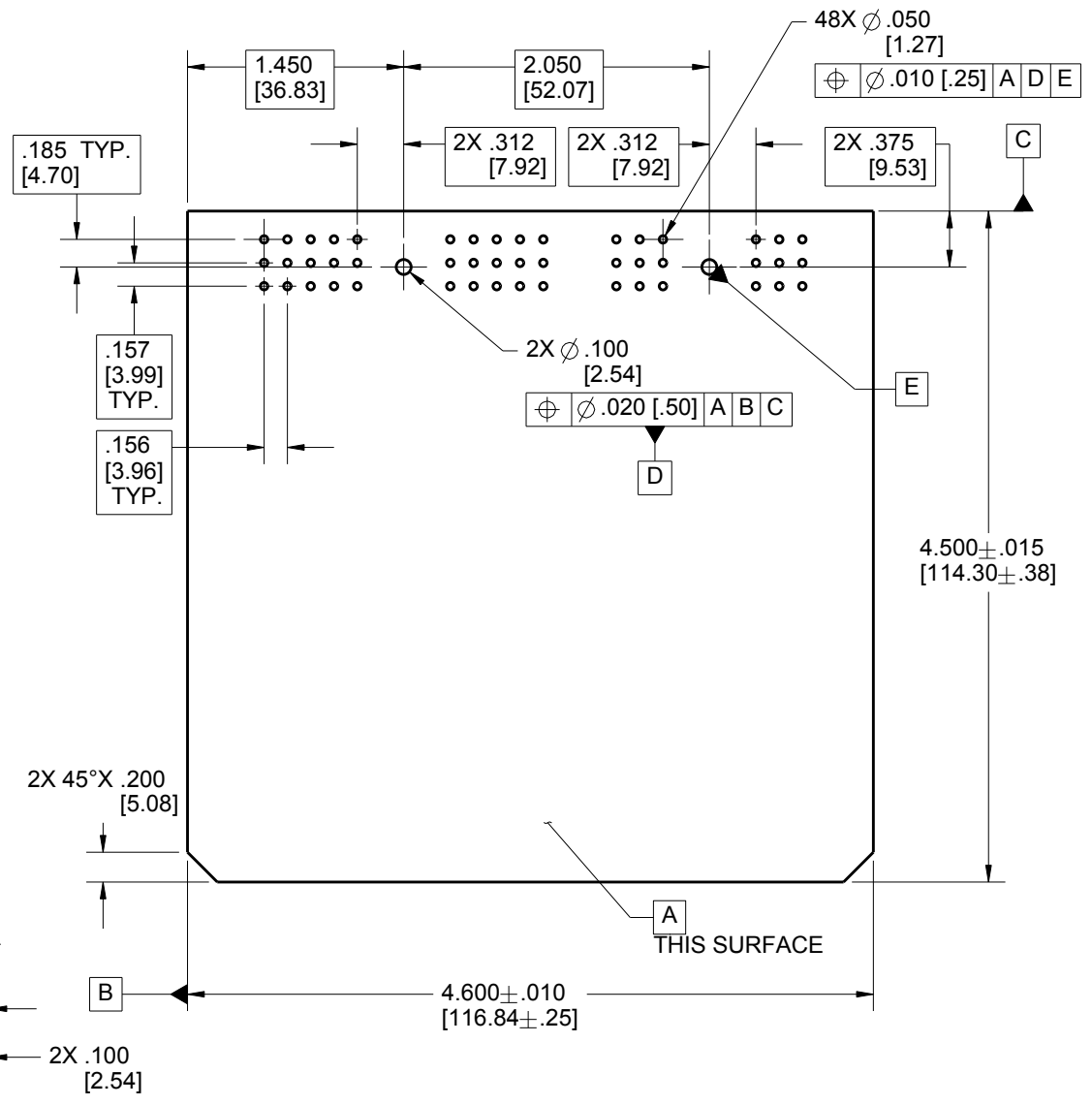

PCB COMPONENT HEIGHT ZONES (SIDE VIEW)

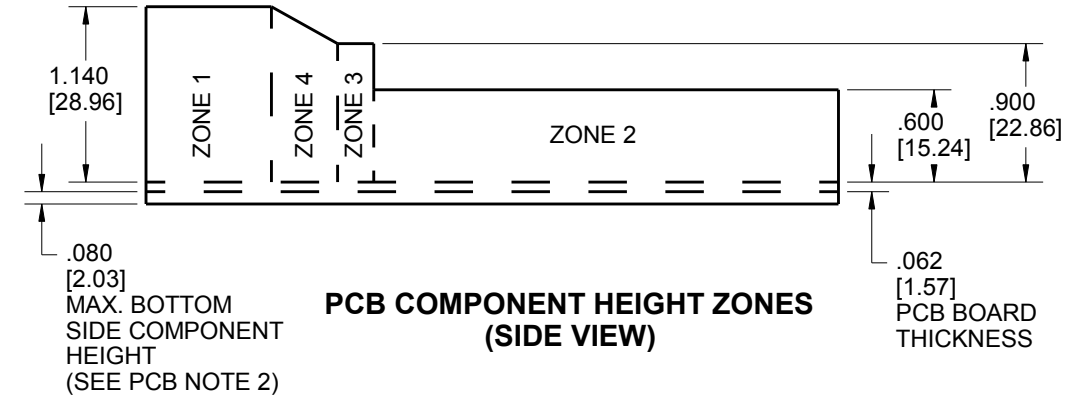

PCB COMPONENTS HEIGHT LIMIT

	ZONE 1	ZONE 2	ZONE 3	ZONE 4
MAX. HEIGHT FOR COMPONENTS (ABOVE PCB)	1.140"	.600"	.900"	SEE PCB NOTE 3

- PCB NOTES:**
- ON BOTTOM SIDE OF THE PCB, COMPONENTS OR TRACES MUST BE MIN. .100" AWAY FROM THE EDGE OF THE PCB.
 - THE BOTTOM SIDE OF THE PCB SHOULD NOT HAVE COMPONENTS OR LEADS THAT EXTEND HIGHER THAN .080" (SEE PG. 6 SIDE VIEW).
 - AREA HAS VARIABLE HEIGHT. SEE PCB COMPONENT HEIGHT ZONES VIEW FOR DETAILS.

UNITS ENGLISH	CINCH		1700 FINLEY RD LOMBARD, IL. 60148
DO NOT SCALE DRAWING	TITLE SE HEADERS MODULAR ICE		
UNLESS OTHERWISE SPECIFIED: ALL DIMENSIONS ARE IN INCHES	PRO/E DRAWING		
FILLET/RADII .02 MAX	TOLERANCES	CAD FILE NUMBER	DRAWING NUMBER
TOLERANCES AND LIMITS APPLY OVER ADDITIVE FINISH	-X ± .1 XX ± .01 XXX ± .005 ANGULAR ± .5°	5810148005S	581 01 48 005 S
THIS DOCUMENT IS THE PROPERTY OF CINCH. NEITHER THIS DOCUMENT NOR ANY OF THE INFORMATION CONTAINED IN IT MAY BE DUPLICATED OR DISCLOSED WITHOUT PRIOR WRITTEN CONSENT OF CINCH.		CAGE IDENT NO. 71785	REV E
		SCALE 4:5	SHEET 3 OF 6

PCB LAYOUT WITH ONE HEAT SINK

PCB TOP SIDE GENERAL ZONING & KEEP OUT AREAS

PCB BOTTOM SIDE GENERAL ZONING & KEEP OUT AREAS

PCB OVERALL DIMENSIONS AND HOLE LOCATIONS

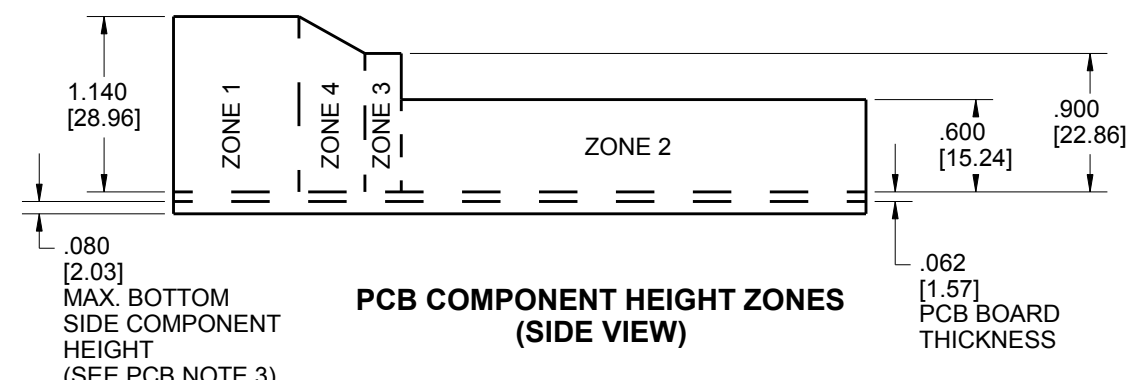
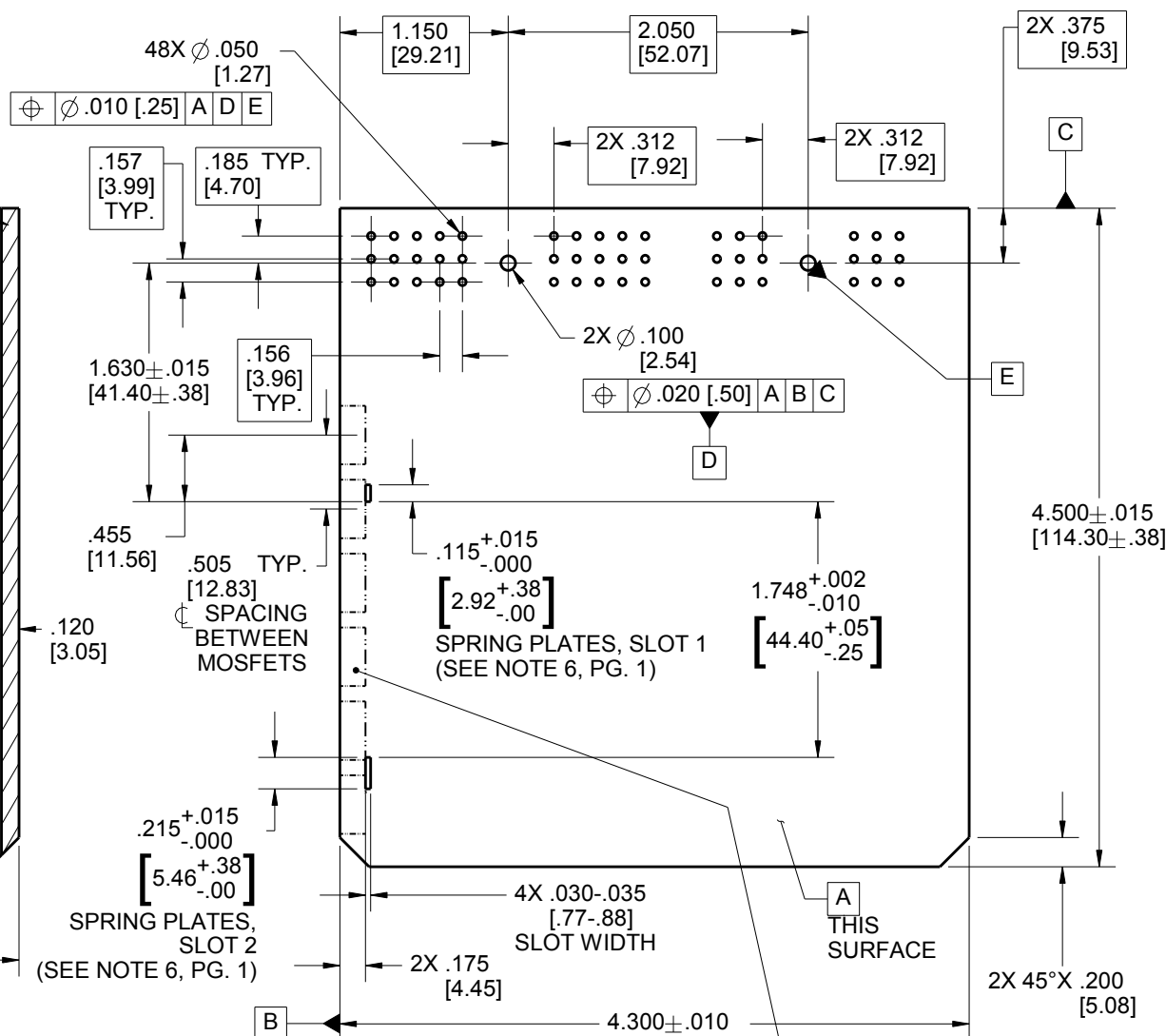
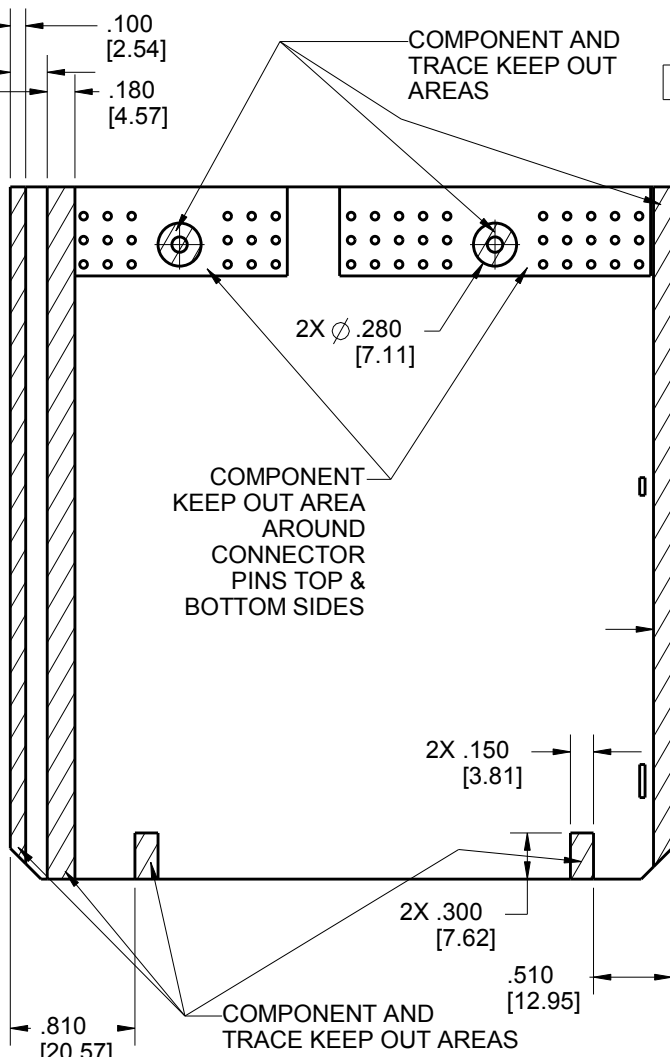
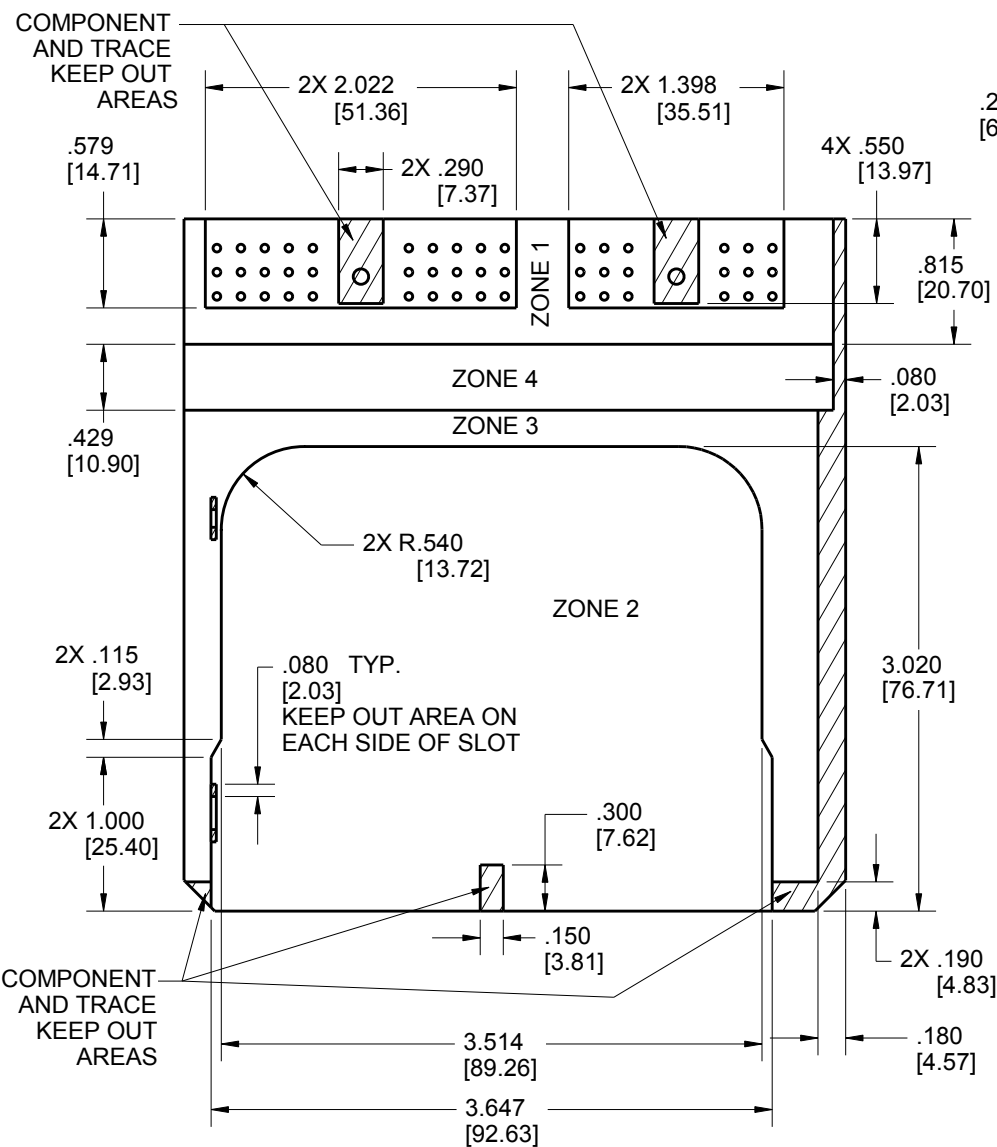

PCB COMPONENTS HEIGHT LIMIT

	ZONE 1	ZONE 2	ZONE 3	ZONE 4
MAX. HEIGHT FOR COMPONENTS (ABOVE PCB)	1.140"	.600"	.900"	SEE PCB NOTE 4

PCB NOTES:

- IF MOSFET SPRINGS ARE USED, ZONE 3 SHOULD CONTAIN ONLY MOSFETS AND TRACES BETWEEN THE SPRINGS AND EDGE OF THE BOARD.
- ON BOTTOM SIDE OF THE PCB, COMPONENTS OR TRACES MUST BE MIN. .100" AWAY FROM THE EDGE OF THE PCB.
- THE BOTTOM SIDE OF THE PCB SHOULD NOT HAVE COMPONENTS OR LEADS THAT EXTEND HIGHER THAN .080" (SEE PG. 6 SIDE VIEW).
- AREA HAS VARIABLE HEIGHT. SEE PCB COMPONENT HEIGHT ZONES VIEW FOR DETAILS.

MOSFET LOCATION(S) MAX. 6 TO-220 STYLE MOSFETS THIS SIDE ONLY. THIS SIDE REQUIRES MOSFET SPRING LABELED AS "R" (SEE NOTE 6, PG. 1)

UNITS	ENGLISH		CINCH		1700 FINLEY RD LOMBARD, IL. 60148
DO NOT SCALE DRAWING	TITLE SE HEADERS MODULAR ICE				
UNLESS OTHERWISE SPECIFIED: ALL DIMENSIONS ARE IN INCHES	TOLERANCES				
FILLET/RADIUS .02 MAX	X ± .1 XX ± .01 XXX ± .005 ANGULAR ± .5°				
TOLERANCES AND LIMITS APPLY OVER ADDITIVE FINISH	THIS DOCUMENT IS THE PROPERTY OF CINCH. NEITHER THIS DOCUMENT NOR ANY OF THE INFORMATION CONTAINED IN IT MAY BE DUPLICATED OR DISCLOSED WITHOUT PRIOR WRITTEN CONSENT OF CINCH.				
CAD FILE NUMBER 5810148005S	DRAWING NUMBER 581 01 48 005 S		REV E		
CAGE IDENT NO. 71785	SIZE B	SCALE 4:5	SHEET 5 OF 6		

8

7

6

5

4

3

2

1

D

D

FOR EASE OF ASSEMBLY
IT IS RECOMMENDED THAT MOSFET(S) BE
TILTED UP TO 10° IN POSITIVE DIRECTION
(SEE DOTTED LINE)

APPLY THIN BEAD OF THERMALLY CONDUCTIVE
ADHESIVE PASTE TO ENTIRE MOSFET SURFACE.
(SEE NOTE 5.)

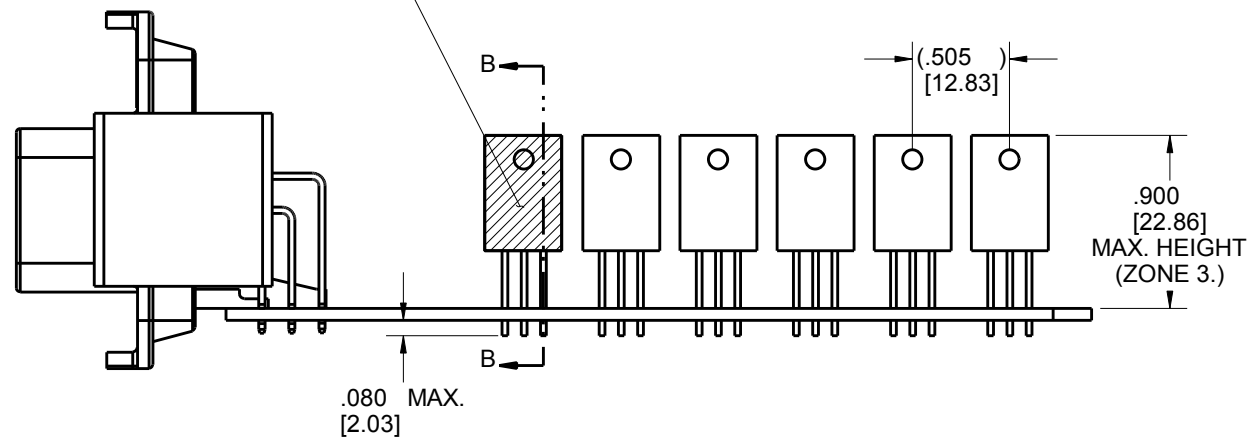

**SIDE VIEW
REQUIRED TO-220 PACKAGE PROFILE**

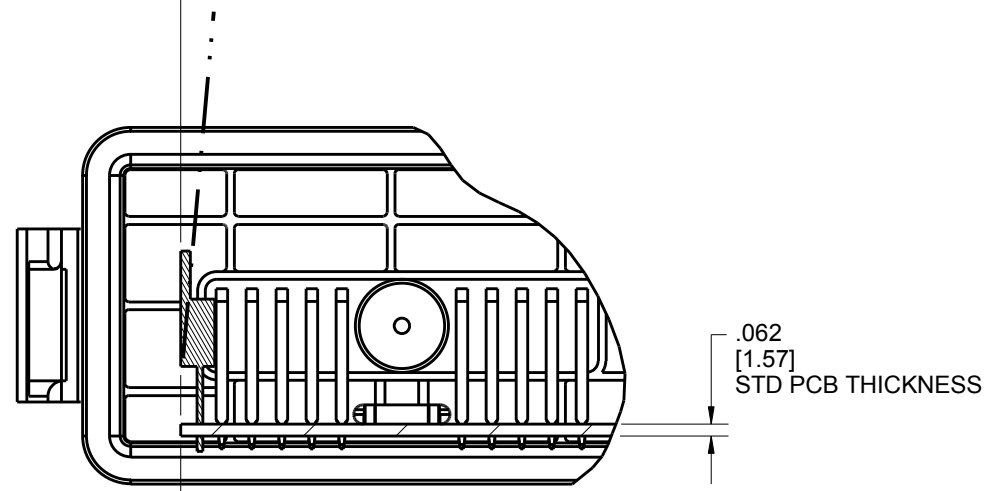

MOSFET MUST LIE IN THE SAME
PLANE WITH EDGE OF PCB
(AS SHOWN)

**REQUIRES TO-220 PACKAGING PROFILE
PARTIAL SECTION B-B**

C

C

B

B

A

8

7

6

5

4

3

2

1

UNITS ENGLISH		CINCH		1700 FINLEY RD LOMBARD, IL. 60148	
DO NOT SCALE DRAWING		TITLE SE HEADERS MODULAR ICE			
UNLESS OTHERWISE SPECIFIED: ALL DIMENSIONS ARE IN INCHES		PRO/E DRAWING			
FILLET/RADII .02 MAX		TOLERANCES X ± .1 XX ± .01 XXX ± .005 ANGULAR ± .5°		CAD FILE NUMBER 5810148005S	DRAWING NUMBER 581 01 48 005 S
TOLERANCES AND LIMITS APPLY OVER ADDITIVE FINISH		CAGE IDENT NO. 71785	SIZE B	SCALE 1:1	REV E
THIS DOCUMENT IS THE PROPERTY OF CINCH. NEITHER THIS DOCUMENT NOR ANY OF THE INFORMATION CONTAINED IN IT MAY BE DUPLICATED OR DISCLOSED WITHOUT PRIOR WRITTEN CONSENT OF CINCH.		SHEET 6 OF 6			



Компания «ЭлектроПласт» предлагает заключение долгосрочных отношений при поставках импортных электронных компонентов на взаимовыгодных условиях!

Наши преимущества:

- Оперативные поставки широкого спектра электронных компонентов отечественного и импортного производства напрямую от производителей и с крупнейших мировых складов;
- Поставка более 17-ти миллионов наименований электронных компонентов;
- Поставка сложных, дефицитных, либо снятых с производства позиций;
- Оперативные сроки поставки под заказ (от 5 рабочих дней);
- Экспресс доставка в любую точку России;
- Техническая поддержка проекта, помощь в подборе аналогов, поставка прототипов;
- Система менеджмента качества сертифицирована по Международному стандарту ISO 9001;
- Лицензия ФСБ на осуществление работ с использованием сведений, составляющих государственную тайну;
- Поставка специализированных компонентов (Xilinx, Altera, Analog Devices, Intersil, Interpoint, Microsemi, Aeroflex, Peregrine, Syfer, Eurofarad, Texas Instrument, Miteq, Cobham, E2V, MA-COM, Hittite, Mini-Circuits, General Dynamics и др.);

Помимо этого, одним из направлений компании «ЭлектроПласт» является направление «Источники питания». Мы предлагаем Вам помощь Конструкторского отдела:

- Подбор оптимального решения, техническое обоснование при выборе компонента;
- Подбор аналогов;
- Консультации по применению компонента;
- Поставка образцов и прототипов;
- Техническая поддержка проекта;
- Защита от снятия компонента с производства.



Как с нами связаться

Телефон: 8 (812) 309 58 32 (многоканальный)

Факс: 8 (812) 320-02-42

Электронная почта: org@eplast1.ru

Адрес: 198099, г. Санкт-Петербург, ул. Калинина, дом 2, корпус 4, литера А.