



### Main

Range of product	Zelio Logic
Product or component type	Modem communication interface
Data backed up	Flash memory

### Complementary

Kit composition	1 x SR2CBL07 Modem communication interface
Product compatibility	SR.B..... SR2E.....
Function available	Send alarm/receive instruction Send alarm to e-mail address Transfer program Update firmware monitoring
Number of messages	<= 28
Electrical data recording	Date and time Discrete and digital value Telephone/e-mail
[Us] rated supply voltage	12...24 V DC
Supply voltage limits	10...28.8 V
Supply current	<= 550 A 30 mA 12 V 30 mA 24 V
Power dissipation in W	1.1 W
Reverse polarity protection	With
Associated fuse rating	1 A
Electrical connection	1 cable Com-M specific to Zelio, RS232 serial, specific Zelio communication protocol link with the modem, AT commands 1 cable Com-Z specific to Zelio, specific Zelio communication protocol Zelio Logic smart relays SR.B..... and SR2 E..... Version (>= V3.1)
Insulation	1780 V optocoupler, connector type: Com-Z specific to Zelio By the cable SR2 CBL07, connector type: Com-M specific to Zelio
Connections - terminals	Screw terminals, 1 x 0.25...1 x 2.5 mm <sup>2</sup> , AWG 24...AWG 14, flexible cable with cable end Screw terminals, 2 x 0.25...2 x 0.75 mm <sup>2</sup> , AWG 24...AWG 18, flexible cable with cable end Screw terminals, 1 x 0.2...1 x 2.5 mm <sup>2</sup> , AWG 25...AWG 14, semi-solid cable Screw terminals, 1 x 0.2...1 x 2.5 mm <sup>2</sup> , AWG 25...AWG 14, solid cable Screw terminals, 2 x 0.2...2 x 1.5 mm <sup>2</sup> , AWG 24...AWG 16, solid cable
Tightening torque	4.42 lbf.in (0.5 N.m)
Product weight	0.44 lb(US) (0.2 kg)

### Environment

product certifications	CSA C-Tick GOST UL
standards	EN/IEC 60068-2-27 Ea EN/IEC 60068-2-6 Fc EN/IEC 61000-4-11 EN/IEC 61000-4-12

The information provided in this documentation contains general descriptions and/or technical characteristics of the performance of the products contained herein. This documentation is not intended as a substitute for and is not to be used for determining suitability or reliability of these products for specific user applications. It is the duty of any such user or integrator to perform the appropriate and complete risk analysis, evaluation and testing of the products with respect to the relevant specific application or use thereof. Neither Schneider Electric Industries SAS nor any of its affiliates or subsidiaries shall be responsible or liable for misuse of the information contained herein.

EN/IEC 61000-4-2 level 3  
 EN/IEC 61000-4-3  
 EN/IEC 61000-4-4 level 3  
 EN/IEC 61000-4-5  
 EN/IEC 61000-4-6 level 3

IP degree of protection	IP20 (terminal block) conforming to IEC 60529 IP40 (front panel) conforming to IEC 60529
environmental characteristic	EMC directive conforming to EN/IEC 61000-6-2 EMC directive conforming to EN/IEC 61000-6-3 EMC directive conforming to EN/IEC 61000-6-4 EMC directive conforming to EN/IEC 61131-2 zone B Low voltage directive conforming to EN/IEC 61131-2
disturbance radiated/conducted	Class B conforming to EN 55022-11 group 1
pollution degree	2 conforming to EN/IEC 61131-2
ambient air temperature for operation	-4...131 °F (-20...55 °C) conforming to IEC 60068-2-1 and IEC 60068-2-2 -4...104 °F (-20...40 °C) conforming to IEC 60068-2-1 and IEC 60068-2-2
ambient air temperature for storage	-40...158 °F (-40...70 °C)
operating altitude	6561.68 ft (2000 m)
altitude transport	<= 10000 ft (3048 m)
relative humidity	95 % without condensation or dripping water

### Offer Sustainability

WARNING: This product can expose you to chemicals including:

WARNING: This product can expose you to chemicals including:

Lead and lead compounds, which is known to the State of California to cause cancer and birth defects or other reproductive harm.

Lead and lead compounds, which is known to the State of California to cause cancer and birth defects or other reproductive harm.

For more information go to [www.p65warnings.ca.gov](http://www.p65warnings.ca.gov)

For more information go to [www.p65warnings.ca.gov](http://www.p65warnings.ca.gov)

### Contractual warranty

Warranty period 18 months

### Communication Interface

#### Rail Mounting

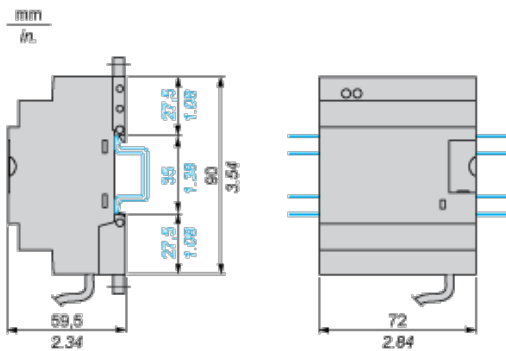

#### Screw Mounting (Retractable Lugs)

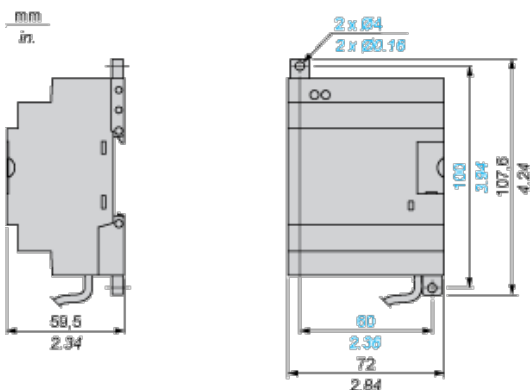



Компания «ЭлектроПласт» предлагает заключение долгосрочных отношений при поставках импортных электронных компонентов на взаимовыгодных условиях!

Наши преимущества:

- Оперативные поставки широкого спектра электронных компонентов отечественного и импортного производства напрямую от производителей и с крупнейших мировых складов;
- Поставка более 17-ти миллионов наименований электронных компонентов;
- Поставка сложных, дефицитных, либо снятых с производства позиций;
- Оперативные сроки поставки под заказ (от 5 рабочих дней);
- Экспресс доставка в любую точку России;
- Техническая поддержка проекта, помощь в подборе аналогов, поставка прототипов;
- Система менеджмента качества сертифицирована по Международному стандарту ISO 9001;
- Лицензия ФСБ на осуществление работ с использованием сведений, составляющих государственную тайну;
- Поставка специализированных компонентов (Xilinx, Altera, Analog Devices, Intersil, Interpoint, Microsemi, Aeroflex, Peregrine, Syfer, Eurofarad, Texas Instrument, Miteq, Cobham, E2V, MA-COM, Hittite, Mini-Circuits, General Dynamics и др.);

Помимо этого, одним из направлений компании «ЭлектроПласт» является направление «Источники питания». Мы предлагаем Вам помощь Конструкторского отдела:

- Подбор оптимального решения, техническое обоснование при выборе компонента;
- Подбор аналогов;
- Консультации по применению компонента;
- Поставка образцов и прототипов;
- Техническая поддержка проекта;
- Защита от снятия компонента с производства.



#### Как с нами связаться

**Телефон:** 8 (812) 309 58 32 (многоканальный)

**Факс:** 8 (812) 320-02-42

**Электронная почта:** [org@eplast1.ru](mailto:org@eplast1.ru)

**Адрес:** 198099, г. Санкт-Петербург, ул. Калинина, дом 2, корпус 4, литера А.