

Ambient Light Sensor

Version 1.1

SFH 5701 A01



Features:

- Analog output current is proportional to Ambient Light Intensity
- Spectral response close to human eye sensitivity
- Integrated dark current suppression
- Built in thermal compensation
- Linear response over 6 decades of illumination range
- The product qualification test plan is referenced to the guidelines of AEC-Q102 (Failure mechanism based stress test qualification for discrete optoelectronic semiconductors in automotive applications.)

Applications

- Sunlight sensor / head lamp control
- Control of display backlighting
- Mobile devices
- Home automation/ smart speakers
- Smart TV
- Industrial displays
- Smart lighting control

Ordering Information

Type:	Output current I_{OUT} [μ A] $V_{DD} = 5$ V, $E_V = 100$ lx (white LED)	Ordering Code
SFH 5701 A01	typ. 135	Q65112A5751

Note: Only one bin within one packing unit, see characteristics.

Maximum Ratings ($T_A = 25\text{ °C}$)

Parameter	Symbol	Values	Unit
Operation temperature range	T_{op}	-40 ... 100	°C
Storage temperature range	T_{stg}	-40 ... 100	°C
Supply voltage (for definition of voltage polarity refer to Appnote AN132)	V_{ddmax}	6	V
Supply current (internally limited; for definition of voltage polarity refer to Appnote AN132))	I_{ddmax}	15	mA
Forward voltage (for definition of voltage polarity refer to Appnote AN132)	V_F	0.56	V
Forward current (for definition of voltage polarity refer to Appnote AN132)	I_F	0.5	mA
ESD withstand voltage (acc. to ANSI/ ESDA/ JEDEC JS-001 - HBM)	V_{ESD}	2000	V
ESD withstand voltage (acc. to ANSI/ ESDA/ JEDEC JS-002 - CDM)	V_{ESD}	750	V
ESD withstand voltage (acc. to ANSI/ ESDA/ JESD22-A115-MM)	V_{ESD}	400	V

Operating Conditions

Parameter	Symbol	Values			Unit
		min	typ	max	
Supply voltage (for the choice of R_{LOAD} refer to Appnote AN132)	V_{dd}	1.45		5.5	V
Supply current ($V_{DD} = 5\text{ V}$, for the choice of R_{LOAD} refer to Appnote AN132)	I_{dd}	0.01		10k	μA
Illuminance range	E_V	0.01		10k	lx

Characteristics ($T_A = 25\text{ °C}$)

Parameter	Symbol	Values	Unit
Spectral sensitivity ($V_{DD} = 5\text{ V}$, $E_V = 100\text{ lx}$, white LED)	(typ) S	1	μA/ lx
Wavelength of max. sensitivity	(typ) $\lambda_{S\ max}$	600	nm
Spectral range of sensitivity	(min) $\lambda_{10\%}$	450	nm
	(max) $\lambda_{10\%}$	705	nm

Parameter		Symbol	Values	Unit
Dimensions of radiant sensitive area	(typ)	L x W	0.33 x 0.33	mm x mm
Half angle	(typ)	φ	± 60	$^{\circ}$
Output impedance	(typ)	Z_{OUT}	10	M Ω
Forward voltage ($I_F = 200 \mu A$, $E = 0$)	(typ)	V_F	0.52	V
Supply current ($V_{DD} = 5 V$, $E_V = 100 \text{ lx}$ (white LED))	(typ)	I_{dd}	135	μA
Output dark current ($V_{DD} = 5 V$, $E_V = 0 \text{ lx}$)	(typ) (max)	I_{OUT_dark} I_{OUT_dark}	3.4 50	nA nA
Rise time ($R_{LOAD} = 33 \text{ k}\Omega$, $E_V = 100 \text{ lx}$, for different testing conditions refer to the Appnote AN132)	(typ)	t_r	14	ms
Temperature coefficient	(typ)	$T_{C\ IOUT}$	-0.07	%/K

Relative Spectral Sensitivity ^{1) page 12}

Photodiode $S_{rel} = f(\lambda)$

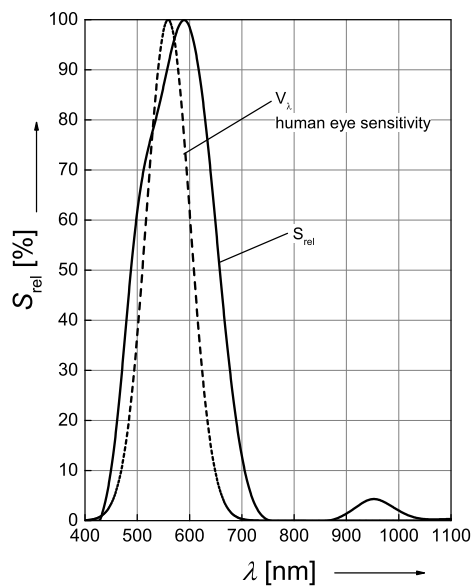

Output Current ^{1) page 12}

$I_{OUT} = f(E_V)$; white LED; $V_{DD} = 5 V$

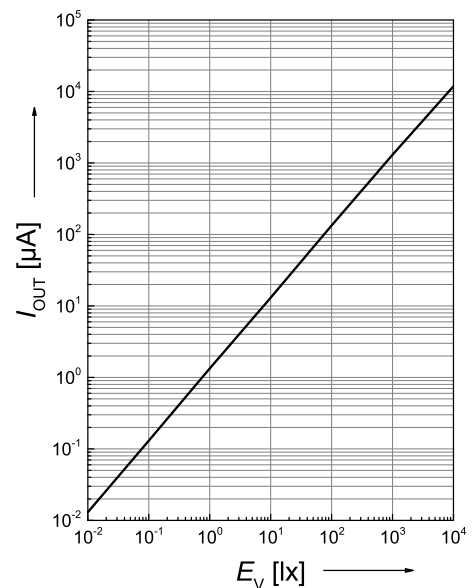

Dark Current ^{1) page 12}

$I_{\text{dark}} = f(V_{\text{DD}})$

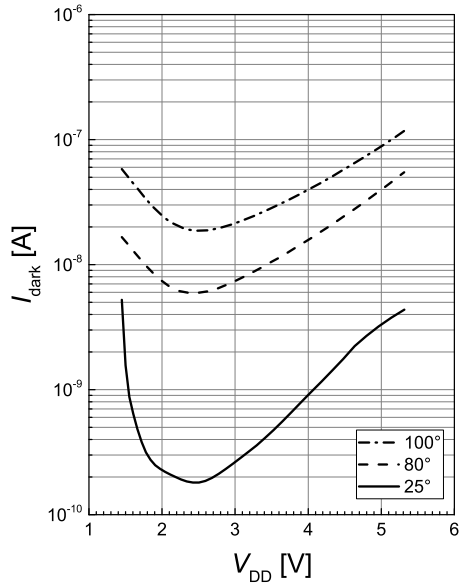

Output Current ^{1) page 12}

$I_{\text{OUT}}(T) / I_{\text{OUT}}(25^{\circ}\text{C}) = f(T_A)$; $E_v = 100\text{lx}$; white LED; $V_{\text{DD}} = 5\text{ V}$

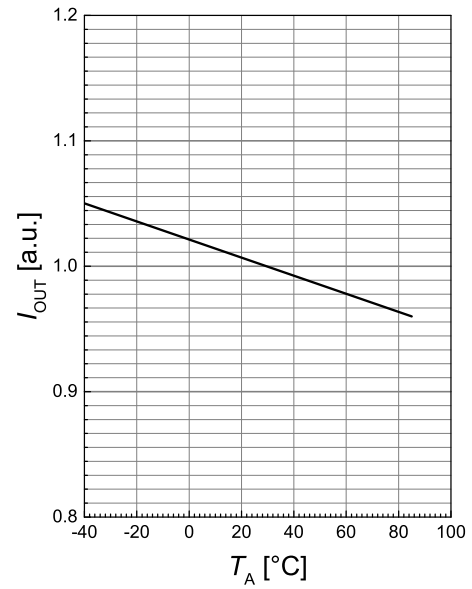

Dark Current ^{1) page 12}

$I_{\text{dark}} = f(T_A)$; $V_F = 5\text{ V}$

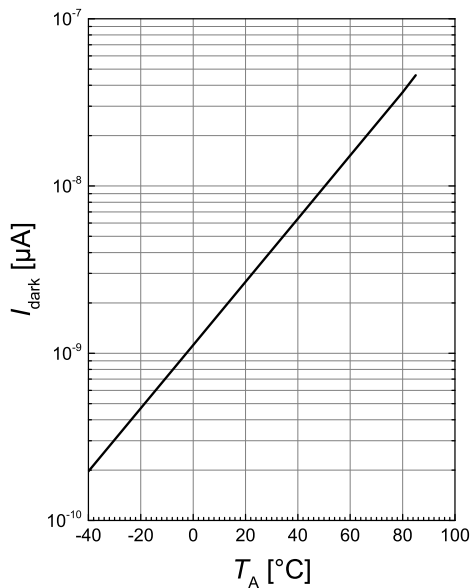

Forward Current ^{1) page 12}

$I_F = f(V_F)$; $E = 0$

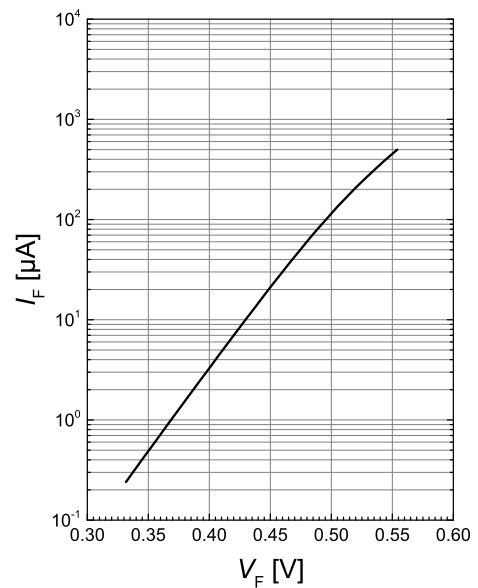

Directional Characteristics (Horizontal) ^{1) page 12}

Photodiode $S_{rel} = f(\phi)$

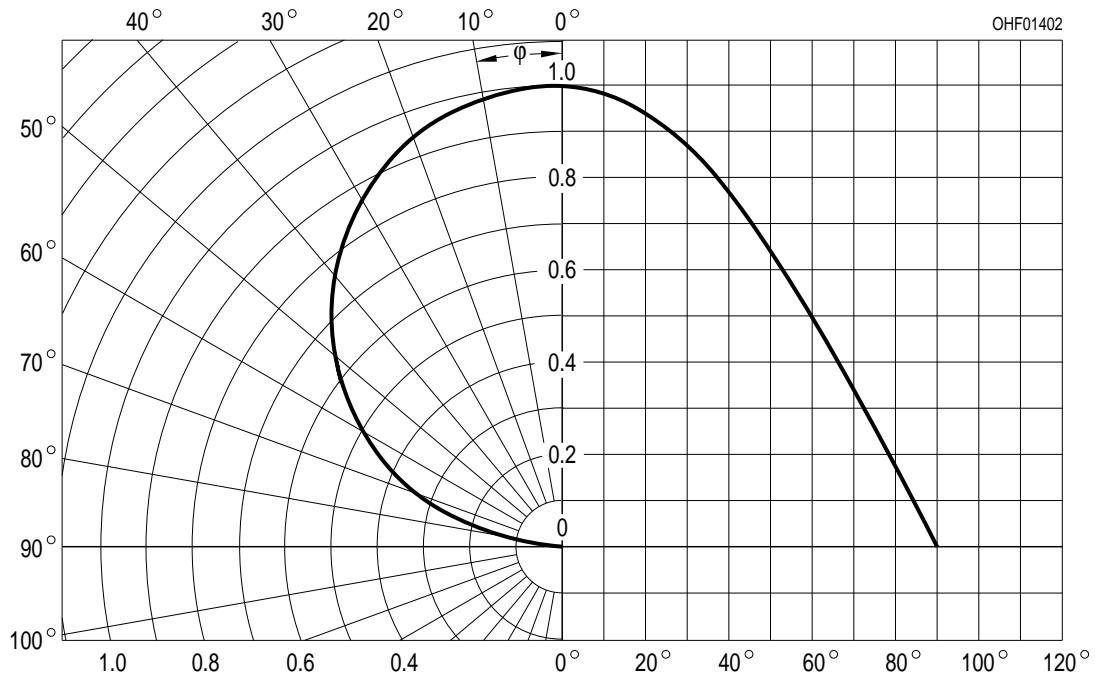

Package Outline

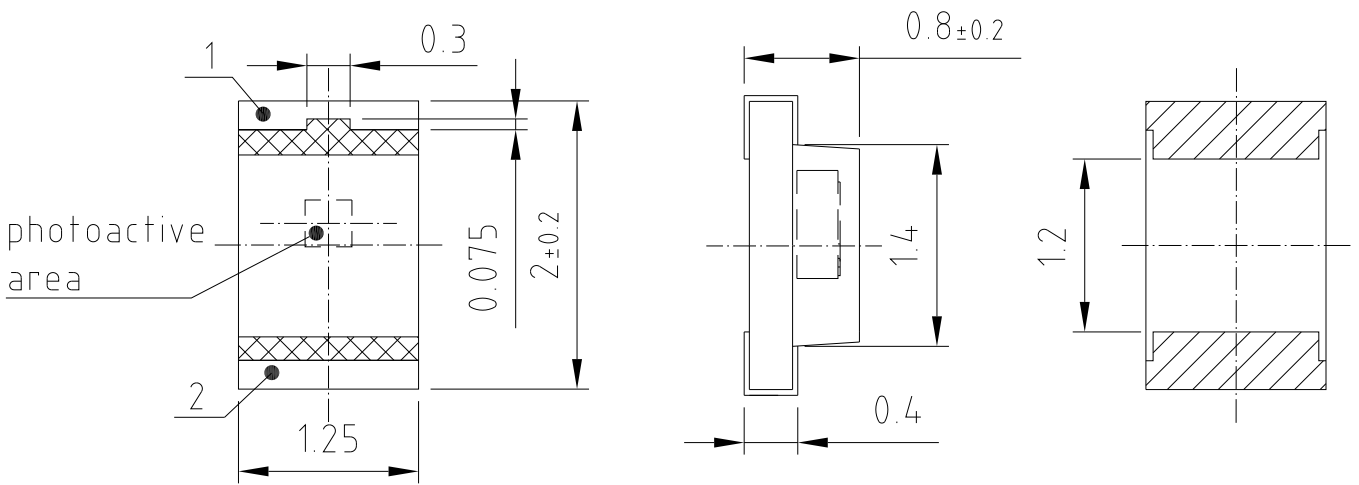

general tolerance ± 0.1
 lead finish Au

C67062-A0260-A1KA-01

Dimensions in mm.

Pinning

Pin	Description
1	anode (OUT)
2	cathode (VDD)

Approximate Weight:

3.8 mg

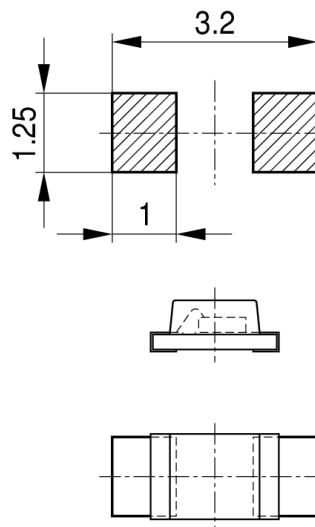
Recommended Solder Pad

Component location on pad

OHFP2578

Dimensions in mm.

Reflow Soldering Profile

Product complies to MSL Level 4 acc. to JEDEC J-STD-020E

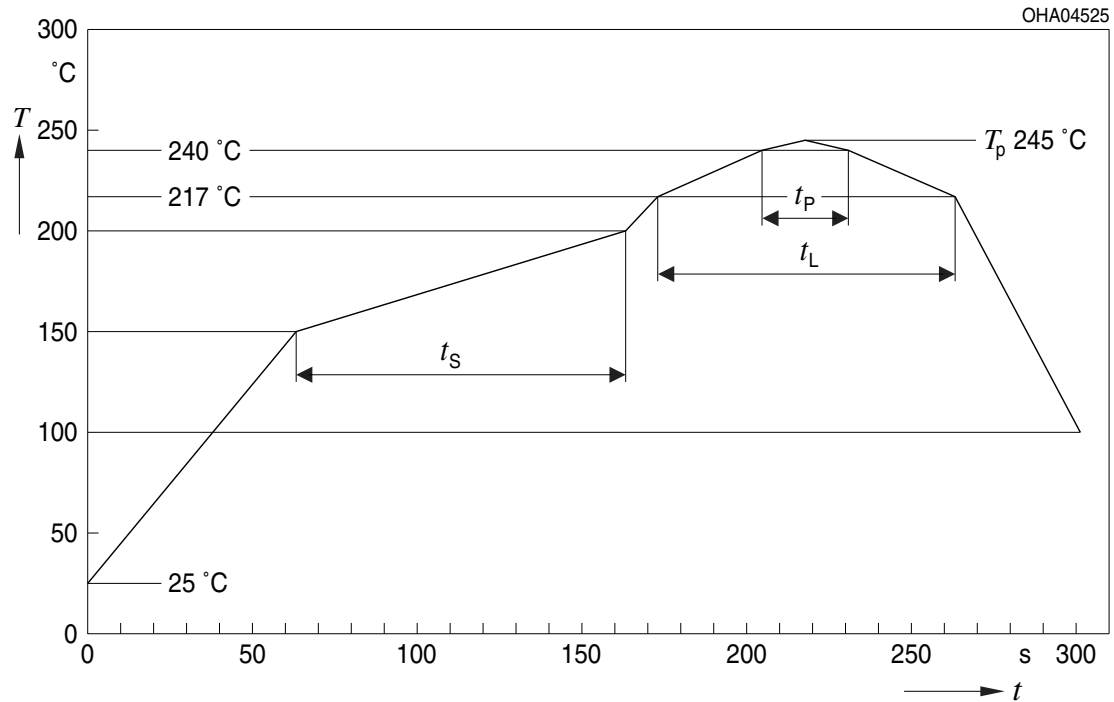

OHA04612

Profil-Charakteristik Profile Feature	Symbol Symbol	Pb-Free (SnAgCu) Assembly			Einheit Unit
		Minimum	Recommendation	Maximum	
Ramp-up Rate to Preheat*) 25 °C to 150 °C			2	3	K/s
Time t_S T_{Smin} to T_{Smax}	t_S	60	100	120	s
Ramp-up Rate to Peak*) T_{Smax} to T_P			2	3	K/s
Liquidus Temperature	T_L	217			°C
Time above Liquidus temperature	t_L		80	100	s
Peak Temperature	T_P		245	260	°C
Time within 5 °C of the specified peak temperature $T_P - 5$ K	t_p	10	20	30	s
Ramp-down Rate* T_P to 100 °C			3	6	K/s
Time 25 °C to T_P				480	s

All temperatures refer to the center of the package, measured on the top of the component

* slope calculation DT/Dt : Dt max. 5 s; fulfillment for the whole T-range

Tape dimensions [mm]

W	P ₀	P ₁	P ₂	D ₀	E	F
8 + 0.3 / -0.1	4 ± 0.1	2 ± 0.05 or 4 ± 0.1	2 ± 0.05	1.5 ± 0.1	1.75 ± 0.1	3.5 ± 0.05

Reel dimensions [mm]

A	W	N _{min}	W ₁	W _{2max}
180	8	60	8.4 + 2	14.4

Barcode-Product-Label (BPL)

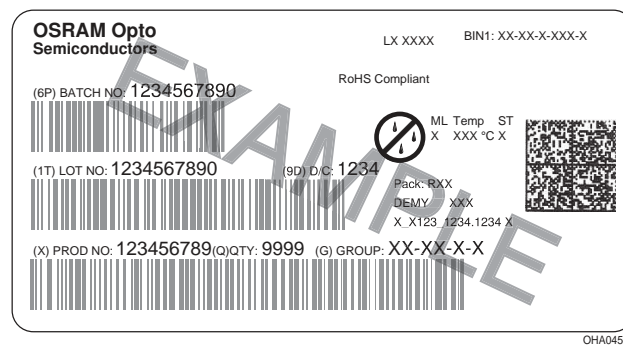

Dry Packing Process and Materials

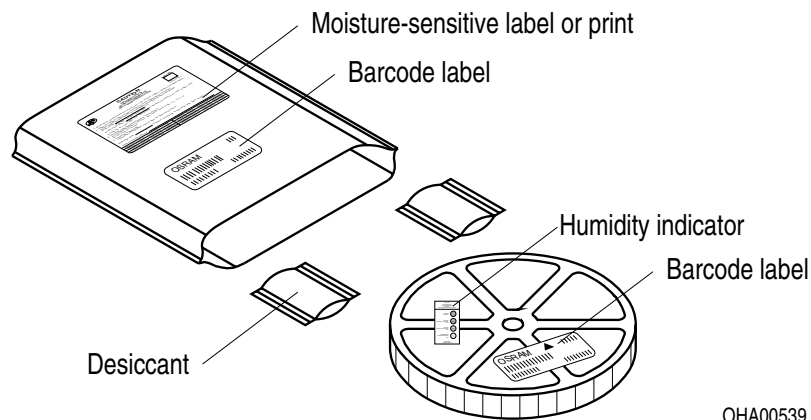

Note:

Moisture-sensitive product is packed in a dry bag containing desiccant and a humidity card. Regarding dry pack you will find further information in the internet. Here you will also find the normative references like JEDEC.

Transportation Packing and Materials

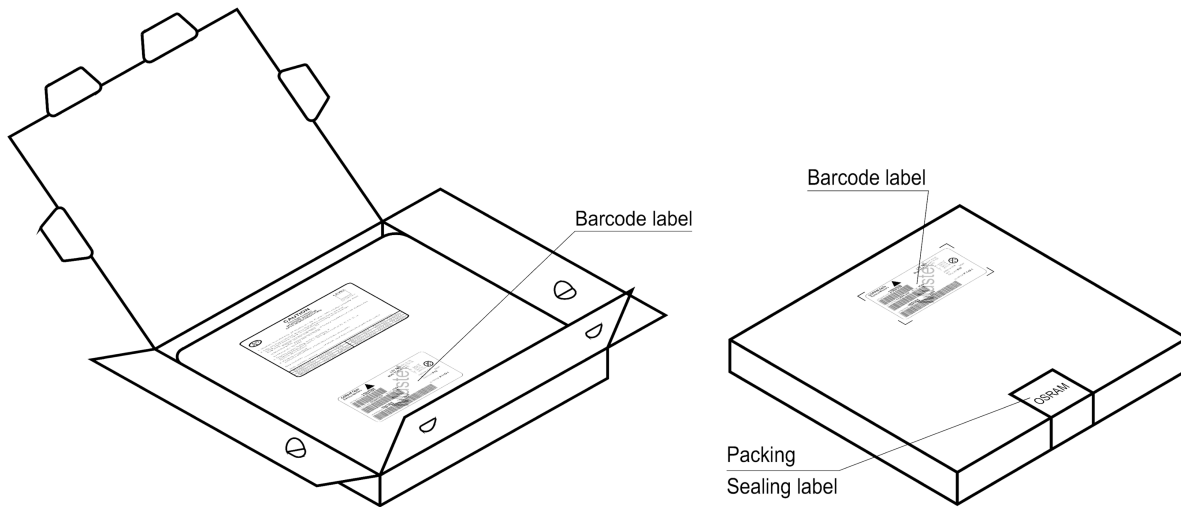

OHA02044

Dimensions of transportation box in mm

Width	Length	Height
200 ± 5	195 ± 5	30 ± 5

Disclaimer

Language english will prevail in case of any discrepancies or deviations between the two language wordings.

Attention please!

The information describes the type of component and shall not be considered as assured characteristics.

Terms of delivery and rights to change design reserved. Due to technical requirements components may contain dangerous substances.

For information on the types in question please contact our Sales Organization. If printed or downloaded, please find the latest version in the Internet.

Packing

Please use the recycling operators known to you. We can also help you – get in touch with your nearest sales office. By agreement we will take packing material back, if it is sorted. You must bear the costs of transport. For packing material that is returned to us unsorted or which we are not obliged to accept, we shall have to invoice you for any costs incurred.

Components used in life-support devices or systems must be expressly authorized for such purpose!

Critical components* may only be used in life-support devices** or systems with the express written approval of OSRAM OS.

*) A critical component is a component used in a life-support device or system whose failure can reasonably be expected to cause the failure of that life-support device or system, or to affect its safety or the effectiveness of that device or system.

**) Life support devices or systems are intended (a) to be implanted in the human body, or (b) to support and/or maintain and sustain human life. If they fail, it is reasonable to assume that the health and the life of the user may be endangered.

Glossary

- ¹⁾ **Typical Values:** Due to the special conditions of the manufacturing processes of LED, the typical data or calculated correlations of technical parameters can only reflect statistical figures. These do not necessarily correspond to the actual parameters of each single product, which could differ from the typical data and calculated correlations or the typical characteristic line. If requested, e.g. because of technical improvements, these typ. data will be changed without any further notice.

Published by OSRAM Opto Semiconductors GmbH
Leibnizstraße 4, D-93055 Regensburg
www.osram-os.com © All Rights Reserved.

EU RoHS and China RoHS compliant product



此产品符合欧盟 RoHS 指令的要求；

按照中国的相关法规和标准，不含有毒有害物质或元素。



Компания «ЭлектроПласт» предлагает заключение долгосрочных отношений при поставках импортных электронных компонентов на взаимовыгодных условиях!

Наши преимущества:

- Оперативные поставки широкого спектра электронных компонентов отечественного и импортного производства напрямую от производителей и с крупнейших мировых складов;
- Поставка более 17-ти миллионов наименований электронных компонентов;
- Поставка сложных, дефицитных, либо снятых с производства позиций;
- Оперативные сроки поставки под заказ (от 5 рабочих дней);
- Экспресс доставка в любую точку России;
- Техническая поддержка проекта, помощь в подборе аналогов, поставка прототипов;
- Система менеджмента качества сертифицирована по Международному стандарту ISO 9001;
- Лицензия ФСБ на осуществление работ с использованием сведений, составляющих государственную тайну;
- Поставка специализированных компонентов (Xilinx, Altera, Analog Devices, Intersil, Interpoint, Microsemi, Aeroflex, Peregrine, Syfer, Eurofarad, Texas Instrument, Miteq, Cobham, E2V, MA-COM, Hittite, Mini-Circuits, General Dynamics и др.);

Помимо этого, одним из направлений компании «ЭлектроПласт» является направление «Источники питания». Мы предлагаем Вам помощь Конструкторского отдела:

- Подбор оптимального решения, техническое обоснование при выборе компонента;
- Подбор аналогов;
- Консультации по применению компонента;
- Поставка образцов и прототипов;
- Техническая поддержка проекта;
- Защита от снятия компонента с производства.



Как с нами связаться

Телефон: 8 (812) 309 58 32 (многоканальный)

Факс: 8 (812) 320-02-42

Электронная почта: org@eplast1.ru

Адрес: 198099, г. Санкт-Петербург, ул. Калинина, дом 2, корпус 4, литера А.