



Actual size



FEATURES

- Measure and display the true-rms current of 3-phase power systems
- Universal 85-264Vac (47-63Hz) operating supply range
- Three built-in current transformers measure up to 100A per phase
- Ideal for power distribution units (PDUs) and backup power systems
- Low power consumption: less than ¼watt from 120Vac supply
- One-piece polycarbonate housing fits '0U' & '1U' rack spaces
- Low-profile surface mount design occupies minimal behind-the-panel space
- Available in red, green, or blue LED-displays with phase annunciators
- Low Cost; UL/CSA approvals pending

PRODUCT OVERVIEW

Murata Power Solutions' ACM3P series 3-phase AC ammeters measure and display the true-rms values of 2- or 3-phase ac mains current. A front panel touch switch enables the selection of a continuous reading of any of the three phases. All ACM3P ammeters are functionally complete, with built-in L1, L2, and L3 current transformers—no other user-supplied components or hardware are required.

ACM3P series AC ammeters are available with a 0-100A input range (150A peaks) and provide a resolution of 0.1 Amp. Their 85-264Vac (47-63Hz) operating supply range makes these ammeters perfect for worldwide 3-phase current monitoring applications. And, unlike conventional average-responding products, ACM3P ammeters can accurately display the true-rms values of triangle waves, square waves, and other irregularly shaped AC current waveforms, with an accuracy of $\pm 2\%$ of full scale.

Their large (0.36"/9.2mm), bright LED display, available in a choice of red, blue, or green, enables ACM3P ammeters to be easily readable from as far as 15 feet (5 meters). All units are packaged in a one-piece, vibration resistant, polycarbonate housing that can be installed in vertical '0U' or horizontal '1U' rack spaces. Their miniature size is ideal for UPS backup power sources, power strips, alternative energy metering, and any other applications that require precise monitoring of 2- or 3-phase ac current.

SIMPLIFIED SCHEMATIC DIAGRAM

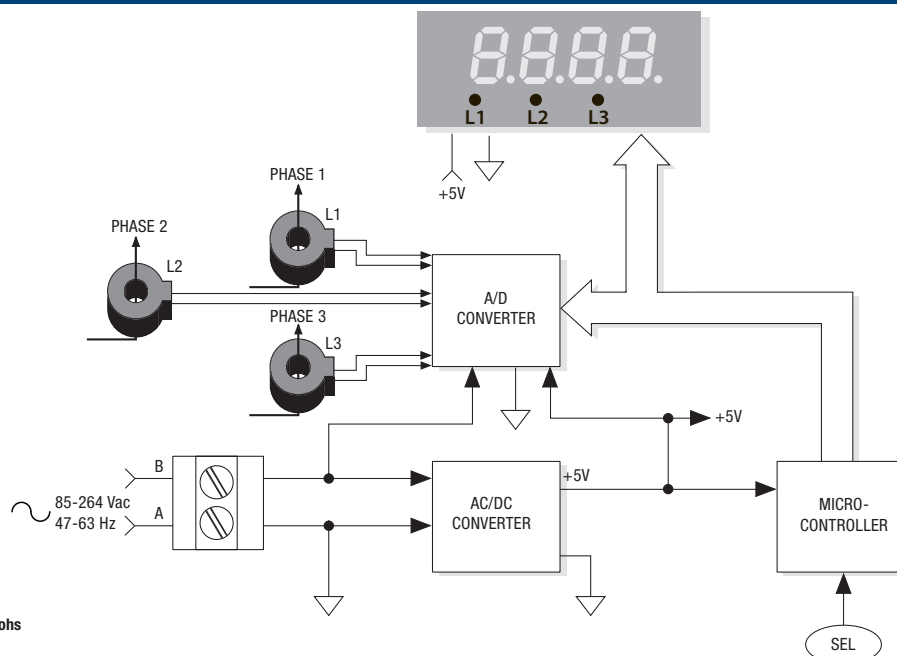

For full details go to
www.murata-ps.com/rohs

Performance/Functional Specifications

Typical at TA=+ 25°C, 120Vac @ 50Hz, unless otherwise noted

Measurement Limits	Min.	Typ.	Max.	Units
AC (rms) Current, L1, L2, L3 ①	0.0	—	100.0	Amperes
Overcurrent Rating ②	1.5 x Rated full-scale current			
Performance				
Sampling Rate	1.5 samples/sec			
Current Accuracy ③		±2%	±3%	
Measurement Bandwidth (L1, L2, L3)	14kHz			
Temperature Drift (0 to 60°C)	0.5 Counts/°C			
Zero-Current Reading (within 1 sec.)	1			Counts
Supply Voltage (TB1)				
All Models	85	120	264	Vac/47-63Hz
Supply Current ④				
ACM3P-X-AC1-R-X-C	35	50	110	mA
ACM3P-X-AC1-G-X-C	50	75	165	mA
ACM3P-X-AC1-B-X-C	50	75	165	mA
Power Supply Terminal Block (TB1)				
Wire Size	16-22AWG, solid or stranded			
Insulation Strip Length	6.4mm (0.250 in)			
Screw Tightening Torque	0.4Nm (3.6 lb-in)			
Rated Voltage	300Vac			
Display				
Display Type and Size	4 Digit LED, 9.14mm (0.36in) high			
Overrange Indication	Flashing display			
Decimal Point Selection	Automatically Set			
Physical/Environmental				
Operating Temperature:	0	—	+60	°C
Storage Temperature:	-40	—	+75	°C
Humidity (non-condensing):	0	—	85	%
Dimensions:	See mechanical specifications			
Weight, all models	2.6 oz (74g)			

Notes

- ① Specified full-scale currents are those passing through the power meter's built-in current transformer's primary load-circuit. See Notes 2 and 3 below for additional information.
- ② The overcurrent rating of 1.5 x the rated full-scale current is a continuous rating and applies to the current passing through the built in current transformer. Accuracy is guaranteed up to the rated current level.
- ③ Power Meters are calibrated with near full-scale 50Hz sine-wave inputs.
- ④ All specified maximum supply currents are steady state. Larger surge currents can occur at initial application of line power.

ORDERING INFORMATION

ACM3P-4-AC1-R-C	100A, 85-264Vac Supply, Red LED Display
ACM3P-4-AC1-G-C	100A, 85-264Vac Supply, Green LED Display
ACM3P-4-AC1-B-C	100A, 85-264Vac Supply, Blue LED Display

TECHNICAL NOTES



IMPORTANT! To ensure safe and reliable operation, ACM3P ammeters must be installed and serviced by qualified technical personnel. Contact Murata Power Solutions if there is any doubt regarding their installation or operation.

1. **Measurement Type:** ACM3P series 3-phase ammeters employ a precision energy metering integrated circuit and a low-power micro-controller to measure and display the rms value of 2- or 3-phase ac-mains current. However, while the unit has an upper bandwidth of 14kHz, dc components or frequencies below 47Hz will not be measured accurately.
2. **Basic Operation:** Upon application of ac power to TB1, the unit will first perform a self-test routine and then continuously display amperes, with one of the three phase-annunciator LEDs illuminated (L1, L2, or L3). The display will remain fixed in one of these reading modes as long as the front panel 'SEL' button is not touched. Assuming phase L1 is initially illuminated, momentarily touching the 'SEL' button two times in succession will cycle the display to phase L2, and then to phase L3. Momentarily touching 'SEL' a third time will return the unit back to displaying phase L1 current.

If power is removed and then restored, the ACM3P will perform a self-test and then return to displaying the last selected phase, i.e., the phase it displayed just before power was removed.

Configuring for 2-Phase Operation: As shipped, ACM3P ammeters are configured to measure and display 3-phase currents (L1, L2, and L3 current transformers are all active). The unit can be set to display 2-phase currents (only L1 and L2 are active) by performing the following procedure:

- A. Press and hold the SEL button for approximately five seconds and then release the button once the words "LinE SEt" appear on the display.
- B. Briefly tapping the SEL button will alternate the display reading between '2-Ph' and '3-Ph' each time SEL is tapped.
- C. To change the factory default 3-phase mode to 2-phase, leave the display fixed in the '2-Ph' reading for at least five seconds.

To revert the unit back to 3-phase operation simply repeat the above procedure but, in step C, allow the unit to display a fixed '3-Ph' for at least five seconds.

3. **Overrange Indication:** ACM3P ammeters have an overcurrent rating of 1.5 times rated current, or 150A. However, accuracy is only guaranteed up to 100A, and the display will flash on and off when the current is at or above 120A.
4. **Calibration:** Due their digital design, ACM3P ammeters cannot be calibrated in the field. ACM3P ammeters are factory-calibrated to meet their specified accuracies with the factory supplied current transformers. Use of any other current transformers will produce significant errors.

Contact Murata Power Solutions if additional information is required regarding calibration, setup, or any other technical issue pertaining to ACM3P ammeters.

TECHNICAL NOTES, CONTINUED

- 5. Wiring:** All power supply and load wiring must be rated for the voltages and currents they will carry and must comply with any code or application-mandated requirements pertaining to the user's specific installation.
- 6. Supply Fusing, and Grounding:** Wires specified in the Functional Specifications section must be used for making connections to ACM3P series ammeters' TB1 terminal block. No connection is required for earth/chassis ground.

ACM3P series ammeters are not internally fused. Terminal block TB1 is to be used only for powering the ammeter's internal circuitry; it must not be used to supply power to external loads. The supply wires feeding these power meters must be fused with a 0.5A/250V time delay/time lag fuse, in accordance with applicable regulatory codes.

Wire insulation must be stripped to within $\pm 10\%$ of the stated dimensions, and wires should be inserted into TB1 such that their insulation is not pinched by the screw terminal.
- 7. Current Transformer Phasing:** Since the ACM3P only measures amperes, transformer phasing is not required. 'Phasing' refers to the direction of the current-carrying wire as it passes through the primary hole of each of the three built-in current transformers.

- 8. Connector Torque Ratings:** It is important to tighten TB1's screw-terminals to their rated torque specification of 3.6 pound-inches (0.4Nm). Proper tightening will minimize connector losses and ensure safe, reliable operation.
- 9. Isolation:** Except for the 2-56 thread metallic mounting studs, all of the ACM3P ammeter's internal components (printed circuit board, resistor, capacitors, current transformers L1, L2 and L3's secondary leads, etc.) are at the ac-mains potential connected to TB1. ACM3P ammeters are designed to be powered from one ac power-source only. Any other connection schemes could introduce significant measurement errors.

The three built-in current transformers have a dielectric breakdown rating of 2kV minimum, allowing them to safely monitor 480V, 3-phase ac mains currents. This dielectric rating pertains only to the insulated load-carrying wire as it passes through the built-in CT's primary hole. However, attention must still be paid to ensure adequate wire-to-wire spacings, and wire-to-metallic surface spacings. Properly rated wiring and fusing must be used for all installations, as noted in Technical Notes 5 and 6 above.

IMPORTANT: Even though ACM3P ac ammeters can be used in 480V current monitoring applications, the ac supply connected to TB1 must never exceed the maximum rating of 264V/47-63Hz.

PANEL INSTALLATION

All connections to ACM3P ammeters must be made after the unit is securely attached to the panel, and with all associated load and supply voltages de-energized (off), using extreme caution and observing all safety measures applicable to the user's installation.

Care should be exercised when passing conductors through the ammeter's built-in current transformers L1, L2, and L3. The installed wire-positions should be such that minimal mechanical forces are applied to the current transformers, TB1, or to the ACM3P ammeter itself. In high-vibration environments, it is strongly recommended that strain reliefs be used for all wiring.

Using Figure 1 as a guide, carefully insert the ACM3P assembly into the panel opening. From the rear of the panel, install and then tighten the four #2-56 hex nuts over the threaded studs. Tighten each nut to 15 to 20 ozf-in (0.106 to 0.140 N-m). Use only the factory-supplied hardware as the use of substitute hardware could result in an unsafe installation and/or adversely affect the reliability of the installation.

The recommended panel thickness range that can be used with the supplied hardware is 0.040 inches (1.0mm) to 0.25 inches (6.4mm). Panel thicknesses outside of this range may require additional user-supplied hardware or modifications.

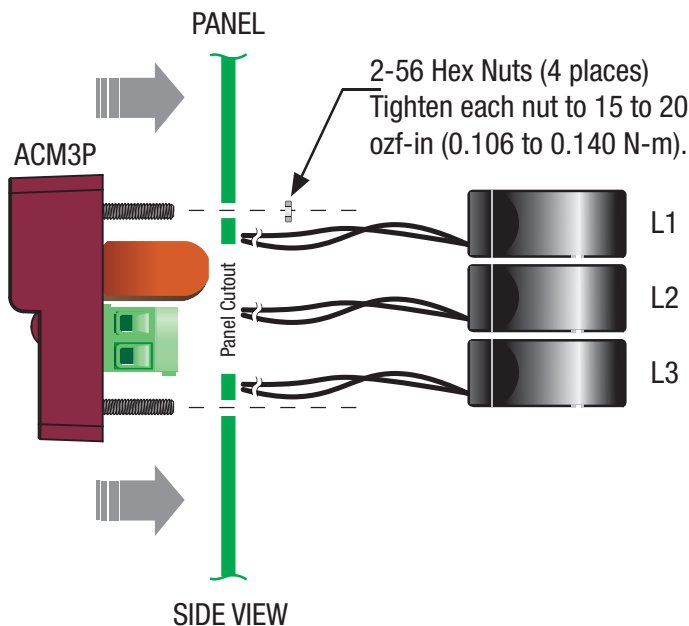

Figure 1. Panel Installation

TYPICAL WIRING DIAGRAMS

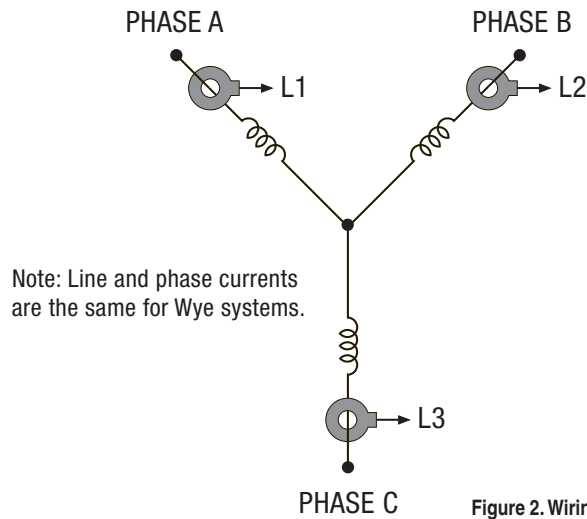
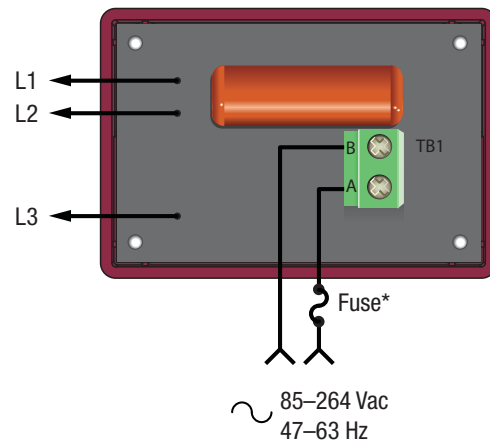

Figure 2. Wiring diagram Wye systems



*See technical note 6.

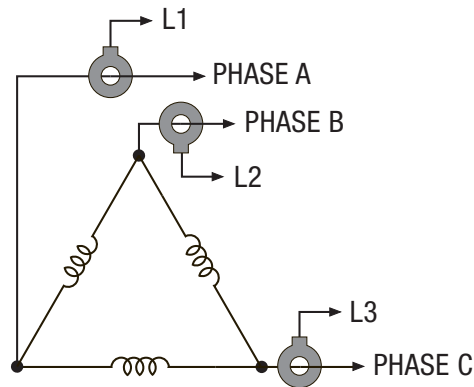
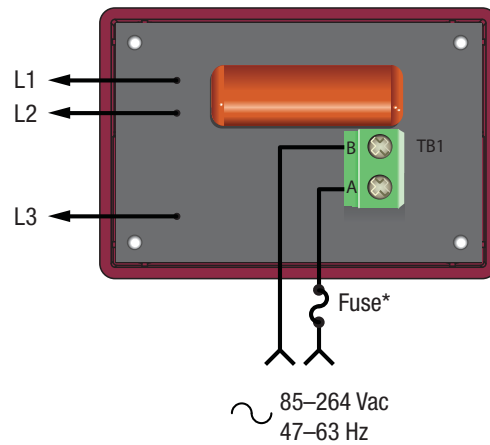

Figure 3. Wiring diagram for Delta systems monitoring line current



*See technical note 6.

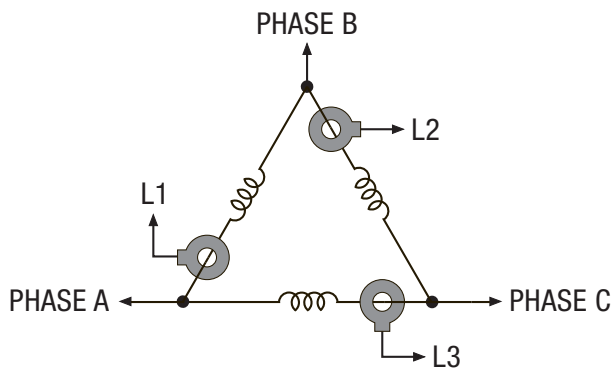
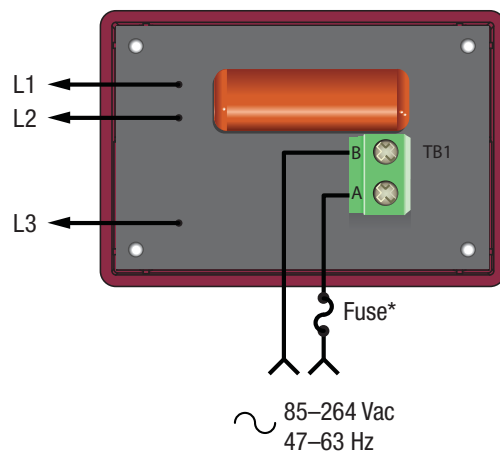

Figure 4. Wiring diagram for Delta systems monitoring phase current



*See technical note 6.

PANEL CUTOUT

RECOMMENDED DRILL AND PANEL CUTOUT DIMENSIONS

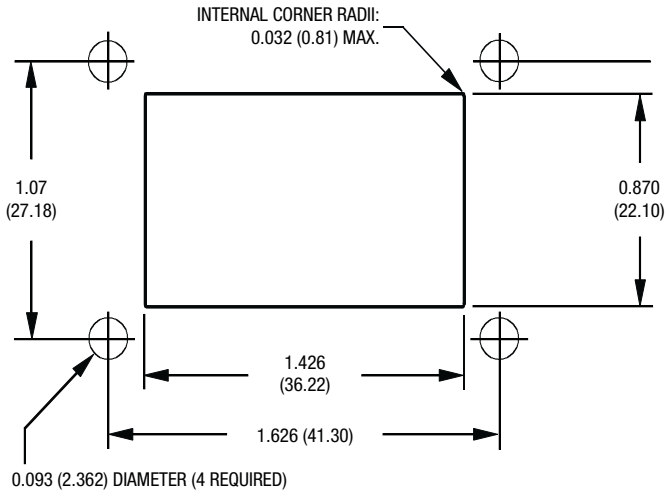

The panel opening must be centered vertically and horizontally between the four 0.093 (2.362mm) diameter holes.

MECHANICAL SPECIFICATIONS

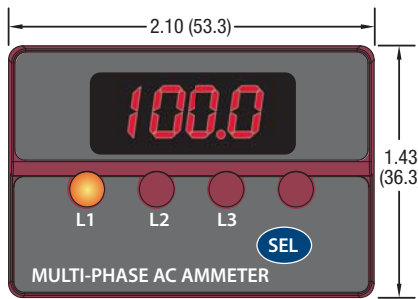

Front View

Dimensions are in inches (mm).

Tolerances (unless otherwise specified):

.XX ± 0.02 (0.51)

.XXX ± 0.010 (0.254)

Angles ± 2°

Components are shown for reference only.

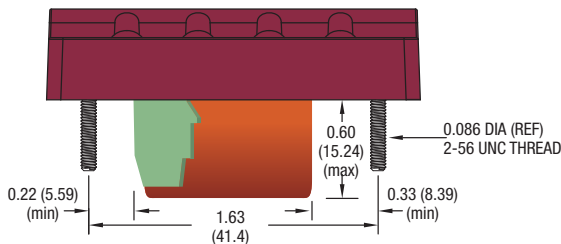
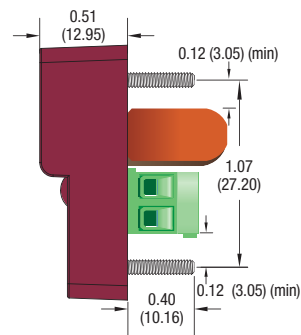

Bottom View

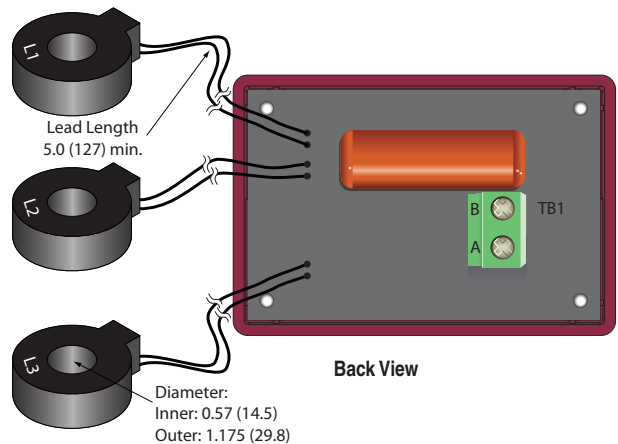

NOTES



Компания «ЭлектроПласт» предлагает заключение долгосрочных отношений при поставках импортных электронных компонентов на взаимовыгодных условиях!

Наши преимущества:

- Оперативные поставки широкого спектра электронных компонентов отечественного и импортного производства напрямую от производителей и с крупнейших мировых складов;
- Поставка более 17-ти миллионов наименований электронных компонентов;
- Поставка сложных, дефицитных, либо снятых с производства позиций;
- Оперативные сроки поставки под заказ (от 5 рабочих дней);
- Экспресс доставка в любую точку России;
- Техническая поддержка проекта, помощь в подборе аналогов, поставка прототипов;
- Система менеджмента качества сертифицирована по Международному стандарту ISO 9001;
- Лицензия ФСБ на осуществление работ с использованием сведений, составляющих государственную тайну;
- Поставка специализированных компонентов (Xilinx, Altera, Analog Devices, Intersil, Interpoint, Microsemi, Aeroflex, Peregrine, Syfer, Eurofarad, Texas Instrument, Miteq, Cobham, E2V, MA-COM, Hittite, Mini-Circuits, General Dynamics и др.);

Помимо этого, одним из направлений компании «ЭлектроПласт» является направление «Источники питания». Мы предлагаем Вам помощь Конструкторского отдела:

- Подбор оптимального решения, техническое обоснование при выборе компонента;
- Подбор аналогов;
- Консультации по применению компонента;
- Поставка образцов и прототипов;
- Техническая поддержка проекта;
- Защита от снятия компонента с производства.



Как с нами связаться

Телефон: 8 (812) 309 58 32 (многоканальный)

Факс: 8 (812) 320-02-42

Электронная почта: org@eplast1.ru

Адрес: 198099, г. Санкт-Петербург, ул. Калинина, дом 2, корпус 4, литера А.