

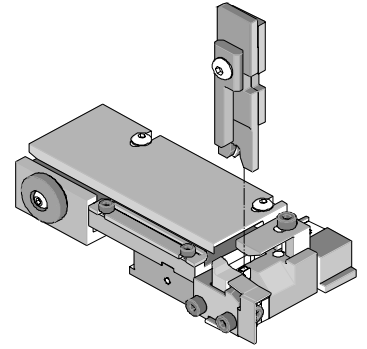

T2 Terminator Tooling Specification Sheet Part No. 63857-1000



FEATURES

- It is ideally suited for mid-volume bench operations
- This terminator can be installed in the TM42 and the TM40 press or Base Unit adapter for 3BF press
- Quick punch removal with the push of a button for fast and easy tooling change
- Track adjustment capabilities in the T2 Terminators for improved control of the bell mouth size and cutoff tab length
- T2 Terminator has standardized tooling with the Molex FineAdjust Applicator which will reduce your inventory requirements

SCOPE

Terminal Series No.	Wire Size		Insulation Diameter		Strip Length	
	AWG	mm ²	mm	In.	mm	In.
94539-1000	20-24	0.50-0.25	2.20 Max.	.087 Max.	4.10-4.60	.161-.181

DEFINITION OF TERMS

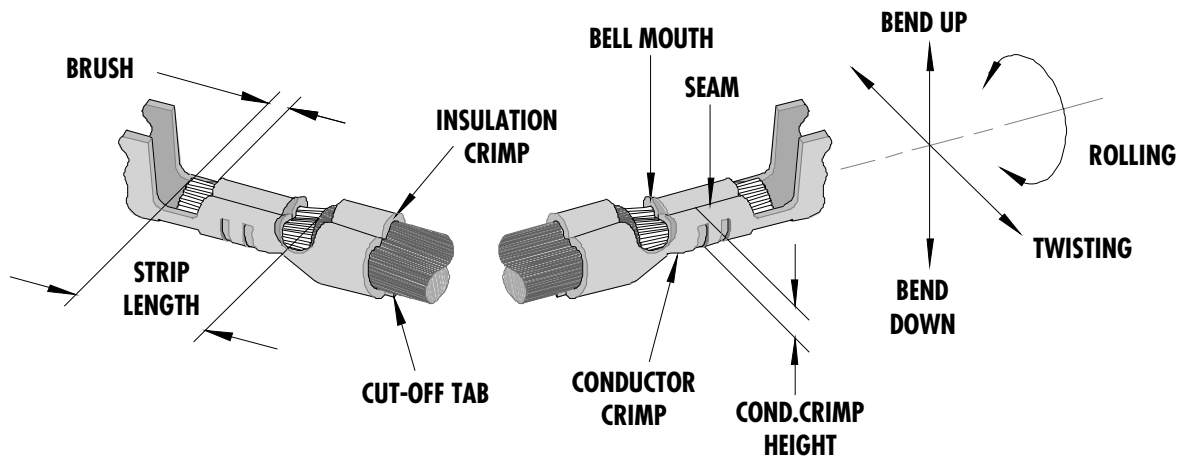

The above terminal drawing is a generic terminal representation. It is not an image of a terminal listed in the scope.

CRIMP SPECIFICATION

Terminal Series No.	Bell mouth		Cut-off Tab Max.		Conductor Brush	
	mm	In.	mm	In.	mm	In.
94539-1000	.20 - .30	.008 - .012	.30	.012	.50 - 1.00	.020 - .040

Terminal Series No.	Bend up	Bend down	Twist	Roll	Punch Width mm (Ref)				Seam Seam shall not be open and no wire allowed out of the crimping area
	Degree		Degree		Conductor		Insulation		
	mm	In	mm	In	mm	In	mm	In	
94539-1000	3	3	4	8	1.42	.056	2.40	.094	

After crimping, the conductor profile should measure the following.

Terminal Series No.	Wire Size		Conductor				Insulation				Pull Force Min.	
			Crimp Height		Crimp Width (Ref)		Crimp Height		Crimp Width (Ref)			
	AWG	mm ²	mm	In.	mm	In.	mm	In.	mm	In.	N	Lb.
94539-1000	20	0.50	0.91-1.01	.036-.040	1.50 Max.	.059 Max.	1.70-1.80	.067-.071	2.45 Max.	.096 Max.	58.8	13.22
94539-1000	22	0.35	0.90-0.98	.035-.039	1.50 Max.	.059 Max.	1.55-1.65	.061-.065	2.45 Max.	.096 Max.	39.2	8.81
94539-1000	24	0.25	0.88-0.96	.035-.038	1.50 Max.	.059 Max.	1.50-1.60	.059-.063	2.45 Max.	.096 Max.	29.4	6.61

Pull Force should be measured with no influence from the insulation crimp.

The above specifications are guidelines to an optimum crimp.

PARTS LIST

Item	Order No	Engineering No.	Description	Quantity
	63857-1000	63857-1000	T2 Terminator (Fig. 1)	REF
1	63457-0024	63457-0024	Conductor Punch	1 Y
2	63455-0026	63455-0026	Conductor Anvil	1 Y
3	63454-0036	63454-0036	Insulation Punch	1 Y
4	63456-0032	63456-0032	Insulation Anvil	1 Y
5	63443-0002	63443-0002	Cut-Off Plunger	1 Y
6	63443-0012	63443-0012	Front Plunger Retainer	1 Y
7	11-24-1067	4996-4	Cut-Off Plunger Spring	1
8	11-40-4039	8302-5	Front Plunger Striker	1
9	63443-0021	63443-0021	Lower Tooling Key	1
10	63443-6005	63443-6005	Rear Cover	1
11	11-18-4083	60707-8	Front Cover	1
12	63443-2515	63443-2515	Anvil Mount	1
13	63443-4025	63443-4025	Wire Stop	1
14	63443-0009	63443-0009	Scrap Chute	1
15	63800-8500	63800-8500	T2 Terminator	1
16	N/A	N/A	M3 by 6Lg. SHCS	2**
17	N/A	N/A	M4 by 6Lg. SHCS	1**
18	N/A	N/A	M4 by 12Lg. BHCS	2**
19	N/A	N/A	M4 by 16Lg. SHCS	1**
20	N/A	N/A	M4 by 50Lg. SHCS	2**
21	N/A	N/A	3MM by 6Lg. Roll Pin	1**
22	N/A	N/A	#10-32 by 3/8"Lg. BHCS	1**
	63857-1070	63857-1070	Tool Kit (All Y Items)	REF

** The following purchased parts are available from an Industrial supply company such as MSC (1-800-645-7270).

Assembly Drawing

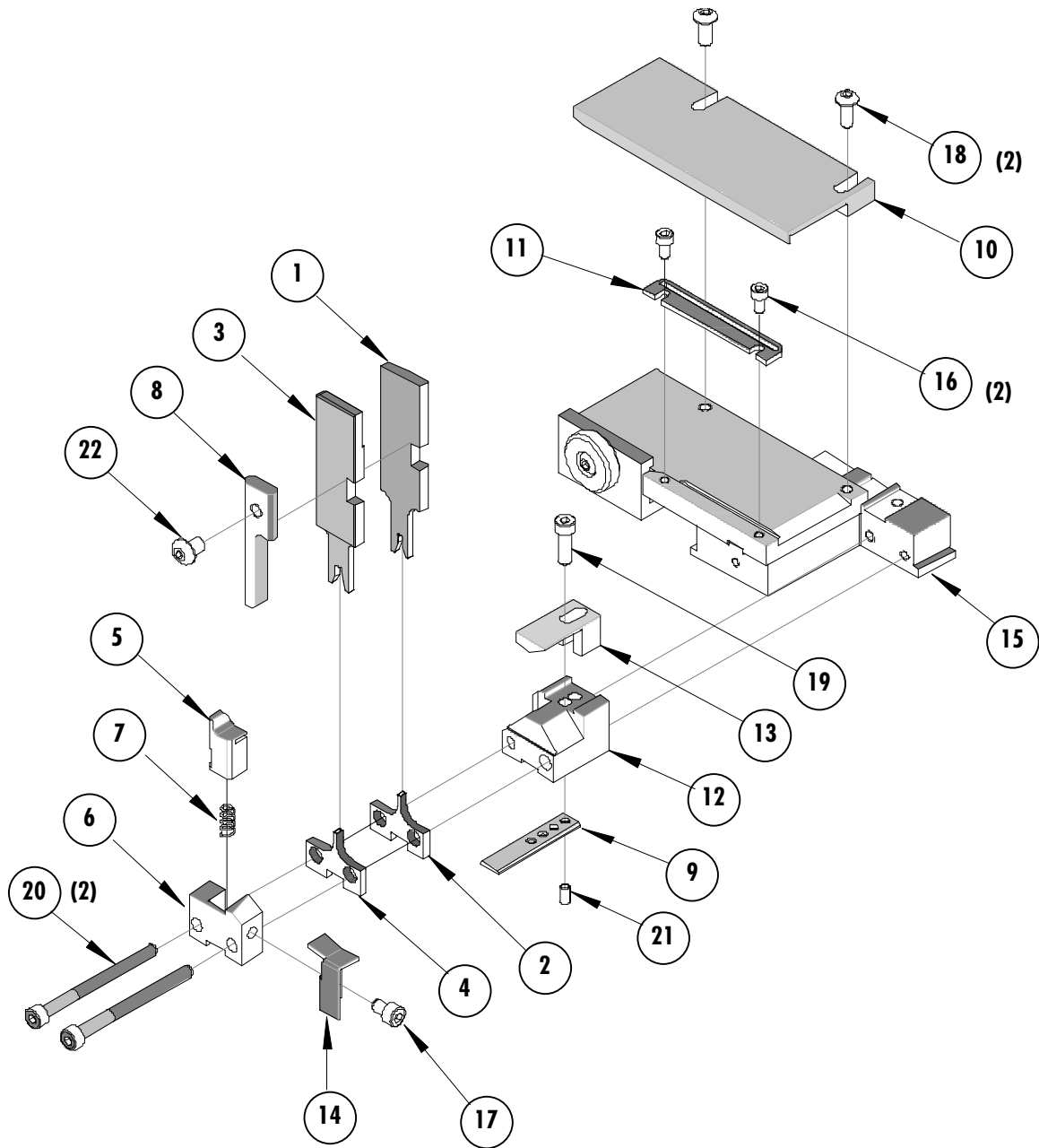

Figure 1

NOTES

Depending on the press vintage a feed finger assembly is supplied with the T2 Terminator.

1. To remove the existing feed finger assembly loosens the M4 x 10 mm set screw in the feed lever.
2. Select T2 Feed finger assembly from Terminator box.
3. Insert a screwdriver into the slot behind the feed lever and force the feed arm spring to the right.
4. Slide the T2 feed finger shaft for TM42 (11-40-5307) or (11-40-0123) for TM40 /Base Unit into the feed lever and to the left of the feed arm spring.
5. Release the feed arm spring.
6. Position feed finger for selected product. (Refer to Figure 5.1 in the T2 Manual).

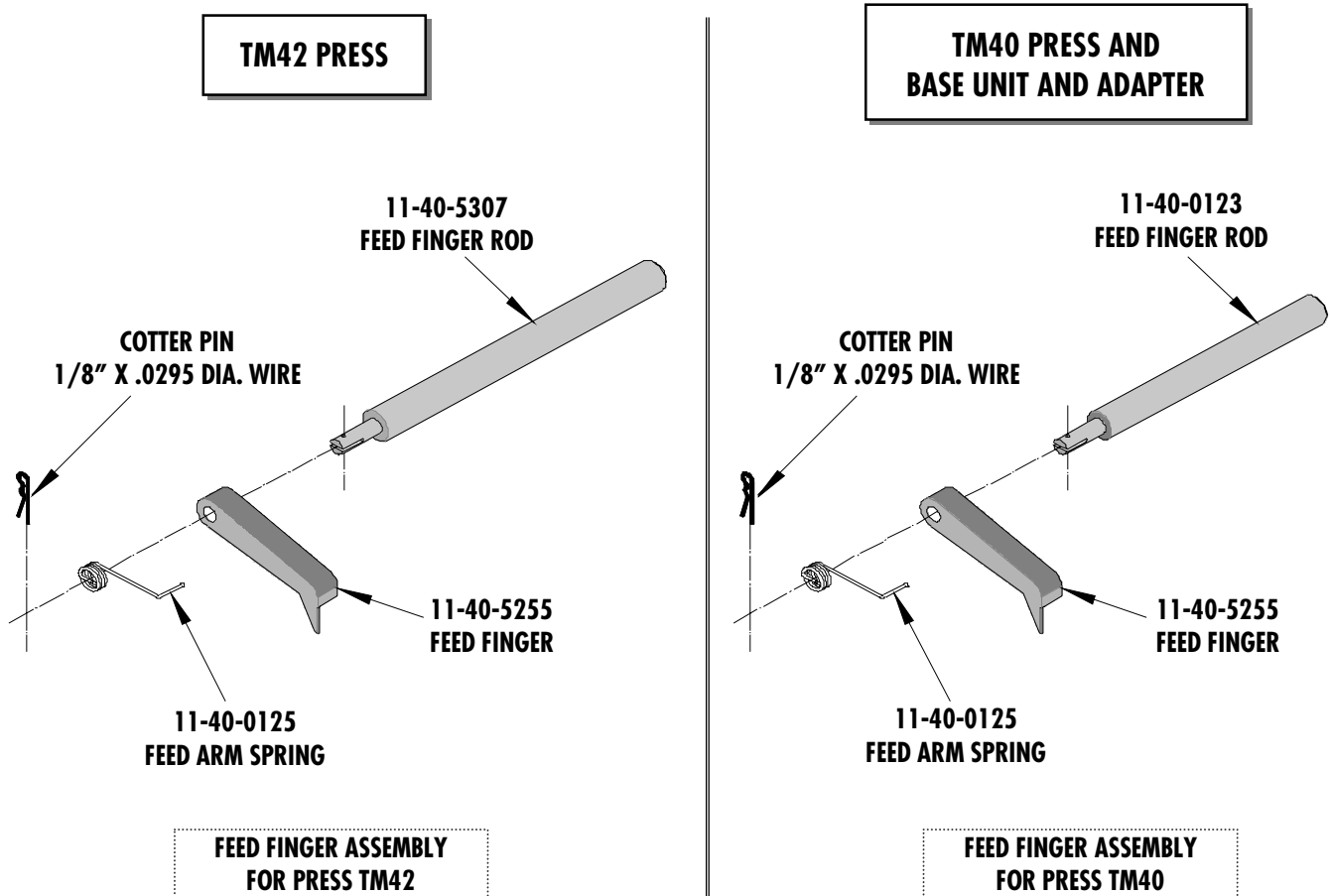

Figure 2

NOTES

1. Molex recommends an extra perishable tooling kit be maintained at your facility.
2. Verify tooling alignment by manually cycling the press before crimping under power. Check that all screws are tight.
3. Slugs, Terminals, Dirt and Oil should be kept clear of work area.
4. This Terminator should be only used in a Molex TM42, TM40, or 3BF Press with a Base Unit adaptor.
5. Wear safety glasses at all times.
6. For recommended maintenance refer to the TM40, TM42 Manual.

CAUTION: To prevent injury never operate this Terminator without the guards supplied with the press or in place. Reference the TM42 press manufacturer's instruction manual.

CAUTION: Molex crimp specifications are valid only when used with Molex terminals, applicators and tooling.

Molex Application Tooling Group

1150 E. Diehl Road
Naperville, IL 60563
Tel: (630) 969-4550
Fax: (630) 505-0049

Visit our Web site at <http://www.molex.com>



Компания «ЭлектроПласт» предлагает заключение долгосрочных отношений при поставках импортных электронных компонентов на взаимовыгодных условиях!

Наши преимущества:

- Оперативные поставки широкого спектра электронных компонентов отечественного и импортного производства напрямую от производителей и с крупнейших мировых складов;
- Поставка более 17-ти миллионов наименований электронных компонентов;
- Поставка сложных, дефицитных, либо снятых с производства позиций;
- Оперативные сроки поставки под заказ (от 5 рабочих дней);
- Экспресс доставка в любую точку России;
- Техническая поддержка проекта, помощь в подборе аналогов, поставка прототипов;
- Система менеджмента качества сертифицирована по Международному стандарту ISO 9001;
- Лицензия ФСБ на осуществление работ с использованием сведений, составляющих государственную тайну;
- Поставка специализированных компонентов (Xilinx, Altera, Analog Devices, Intersil, Interpoint, Microsemi, Aeroflex, Peregrine, Syfer, Eurofarad, Texas Instrument, Miteq, Cobham, E2V, MA-COM, Hittite, Mini-Circuits, General Dynamics и др.);

Помимо этого, одним из направлений компании «ЭлектроПласт» является направление «Источники питания». Мы предлагаем Вам помощь Конструкторского отдела:

- Подбор оптимального решения, техническое обоснование при выборе компонента;
- Подбор аналогов;
- Консультации по применению компонента;
- Поставка образцов и прототипов;
- Техническая поддержка проекта;
- Защита от снятия компонента с производства.



Как с нами связаться

Телефон: 8 (812) 309 58 32 (многоканальный)

Факс: 8 (812) 320-02-42

Электронная почта: org@eplast1.ru

Адрес: 198099, г. Санкт-Петербург, ул. Калинина, дом 2, корпус 4, литера А.