



SF2109D

**305.00 MHz
SAW Filter**

- **Low Insertion Loss**
- **3.8 X 3.8 X 1.2 mm Surface-Mount Case**
- **Differential 750 Ohm IN and 900 Ohm OUT**
- **Complies with Directive 2002/95/EC (RoHS)**



Absolute Maximum Ratings

Rating	Value	Units
Maximum Incident Power in Passband	+10	dBm
Max. DC voltage between any 2 terminals	30	VDC
Storage Temperature Range	-40 to +85	°C
Operating Temperature	-15 to +85	°C
Suitable for lead-free soldering - Max Soldering Profile	260°C for 30 s	

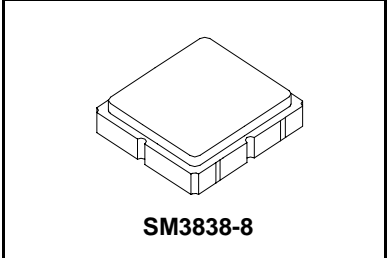

Electrical Characteristics

Characteristic	Sym	Notes	Min	Typ	Max	Units
Center Frequency	f _C	1		305		MHz
Insertion Loss	IL	1		7	10	dB
Amplitude Ripple (p-p)	fc-4.0 to fc+4.0 MHz	1, 2		1.2	2.0	dB
Low Side Attenuation (fc-9.28 MHz)			30	35		dB
Low Side Attenuation (fc-5.78 MHz)			25	35		
High Side Attenuation (fc+5.78 MHz)			20	26		
High Side Attenuation (fc+9.28 MHz)			30	35		
Delay Ripple (p-p)	fc-4.0 to fc+4.0 MHz	1, 2, 3			300	ns
Group Delay in Passband					500	
Case Style		6	SM3838-8 3.8 x 3.8 mm Nominal Footprint			
Lid Symbolization (Y=year, WW=week, S=shift) See note 4			607 YWWS			



CAUTION: Electrostatic Sensitive Device. Observe precautions for handling.

Notes:

1. Unless noted otherwise, all specifications apply over the operating temperature range with filter soldered to the specified demonstration board with impedance matching to 50 Ω and measured with 50 Ω network analyzer.
2. Unless noted otherwise, all frequency specifications are referenced to the nominal center frequency, fc.
3. Rejection is measured as attenuation below the minimum IL point in the passband. Rejection in final user application is dependent on PCB layout and external impedance matching design. See Application Note No. 42 for details.
4. The design, manufacturing process, and specifications of this filter are subject to change.
5. Tape and Reel Standard Per ANSI / EIA 481.
6. US and international patents may apply.
7. RFM, stylized RFM logo, and RF Monolithics, Inc. are registered trademarks of RF Monolithics, Inc.
8. ©Copyright 1999, RF Monolithics Inc.

3 Mar 2006 13:02:04

CH1 S11 1 UFS
 1: 37.277 Ω 3.1523 Ω 1.6450 nH
 305.000 000 MHz
 SF2109D 50 ohm demo

CH3 S22 1 UFS
 1: 52.984 Ω 7.2871 Ω 3.8026 nH
 305.000 000 MHz

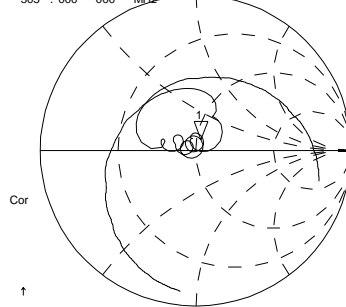
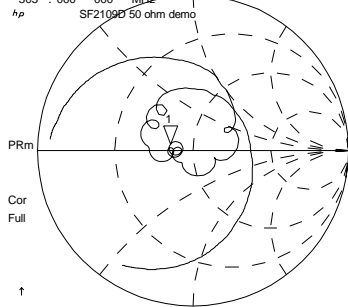

CH2 S21 LOG 10 dB/ REF -7.046 dB

1: 0.0000 dB 0.000 000 MHz

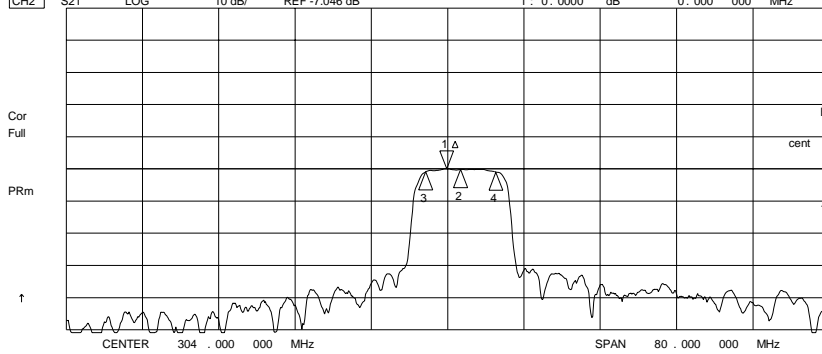

CH2 Markers
 Max Δ REF=1
 BW: 7.378194 MHz
 cent: 305.380082 MHz
 Q: 41.390
 loss: -7.0214 dB

3 Mar 2006 13:05:41

CH1 S21 DEL 100 ns/ REF 500 ns

3: 22.793 ns -8.000 000 MHz

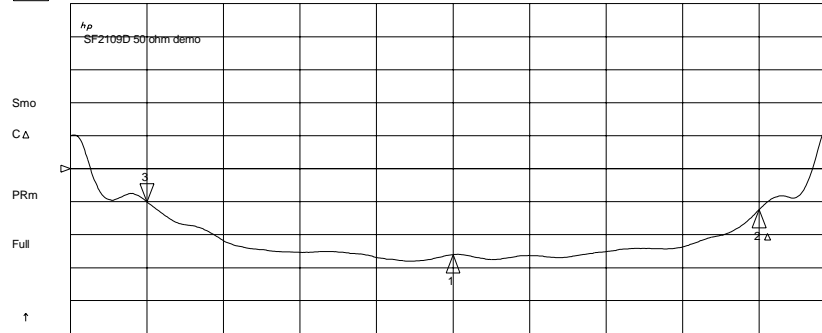

CH1 Markers
 Δ REF=2
 mean: 262.50 ns
 s. dev: 39.617 ns
 p-p: 179.82 ns

CH2 S21 LOG 1 dB/ REF -7.046 dB

3: -.37930 dB -8.000 000 MHz

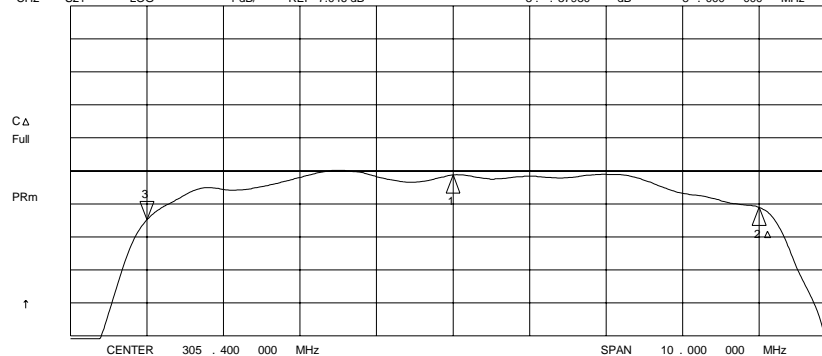

CH2 Markers
 Δ REF=2
 mean: -7.4435 dB
 s. dev: 0.32180 dB
 p-p: 1.4982 dB

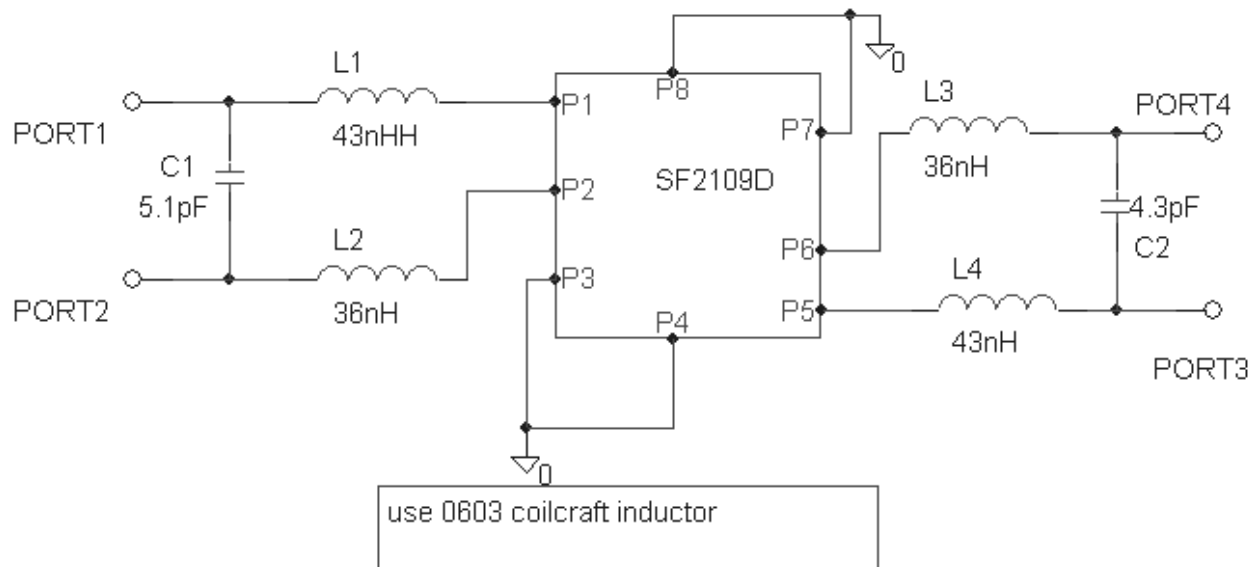
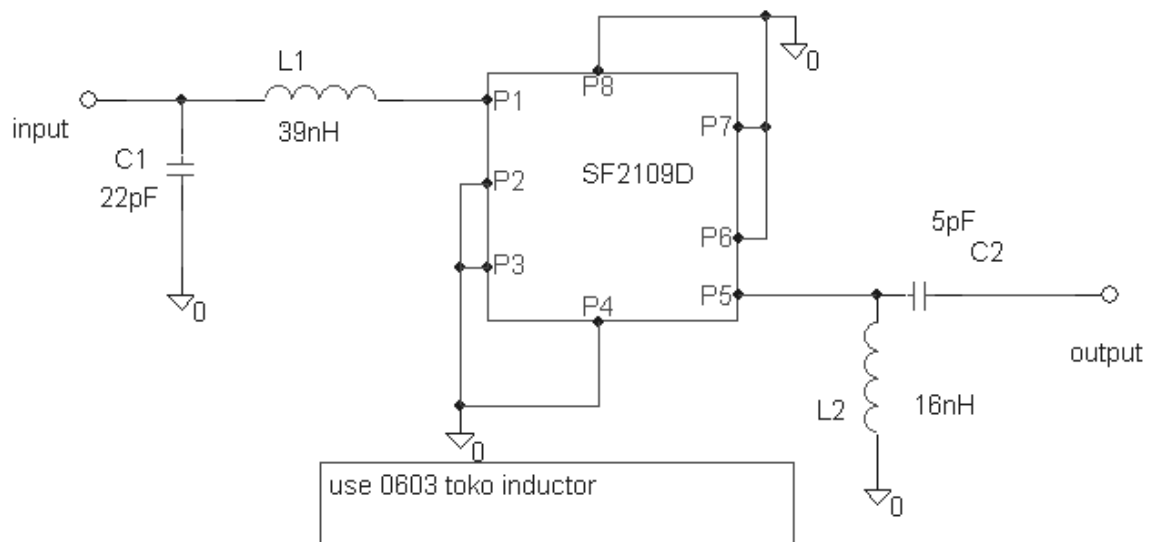

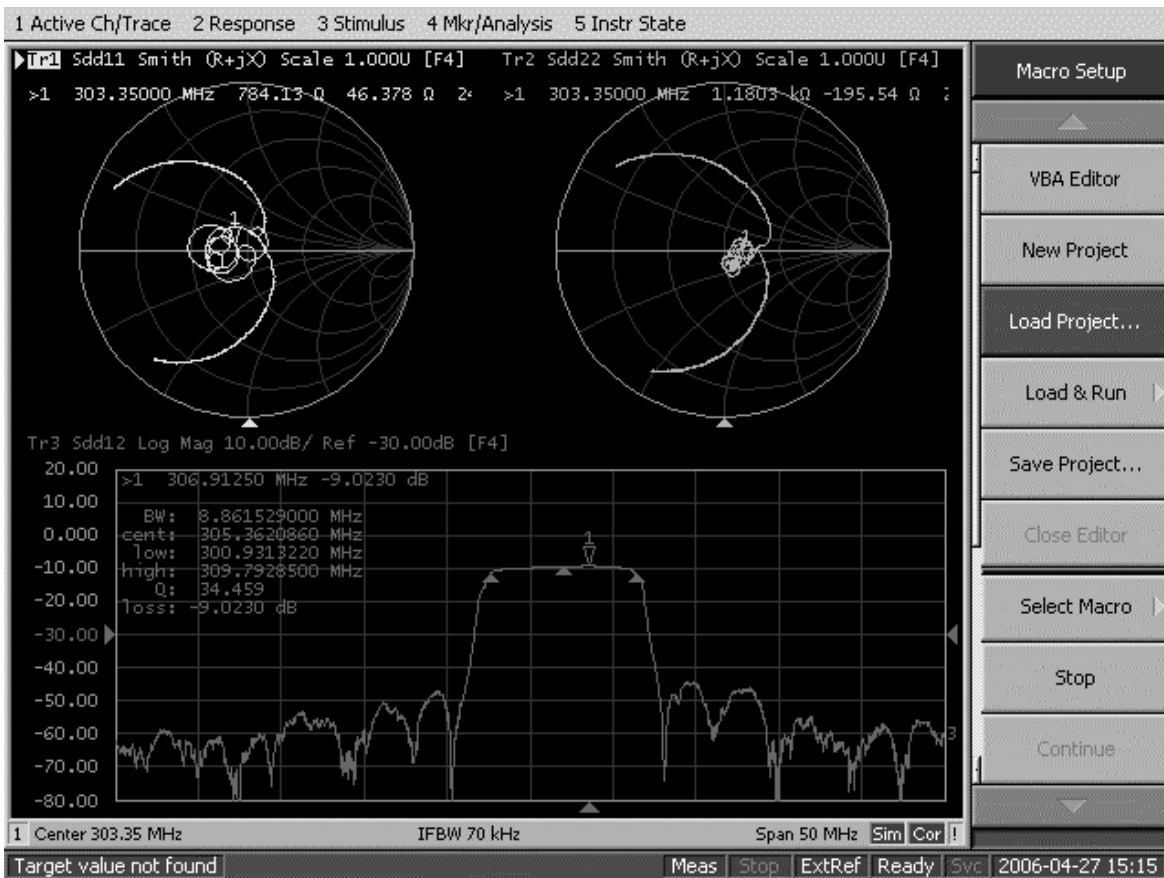

Macro Setup

VBA Editor

New Project

Load Project...

Load & Run ▶

Save Project...

Close Editor

Select Macro ▶

Stop

Continue

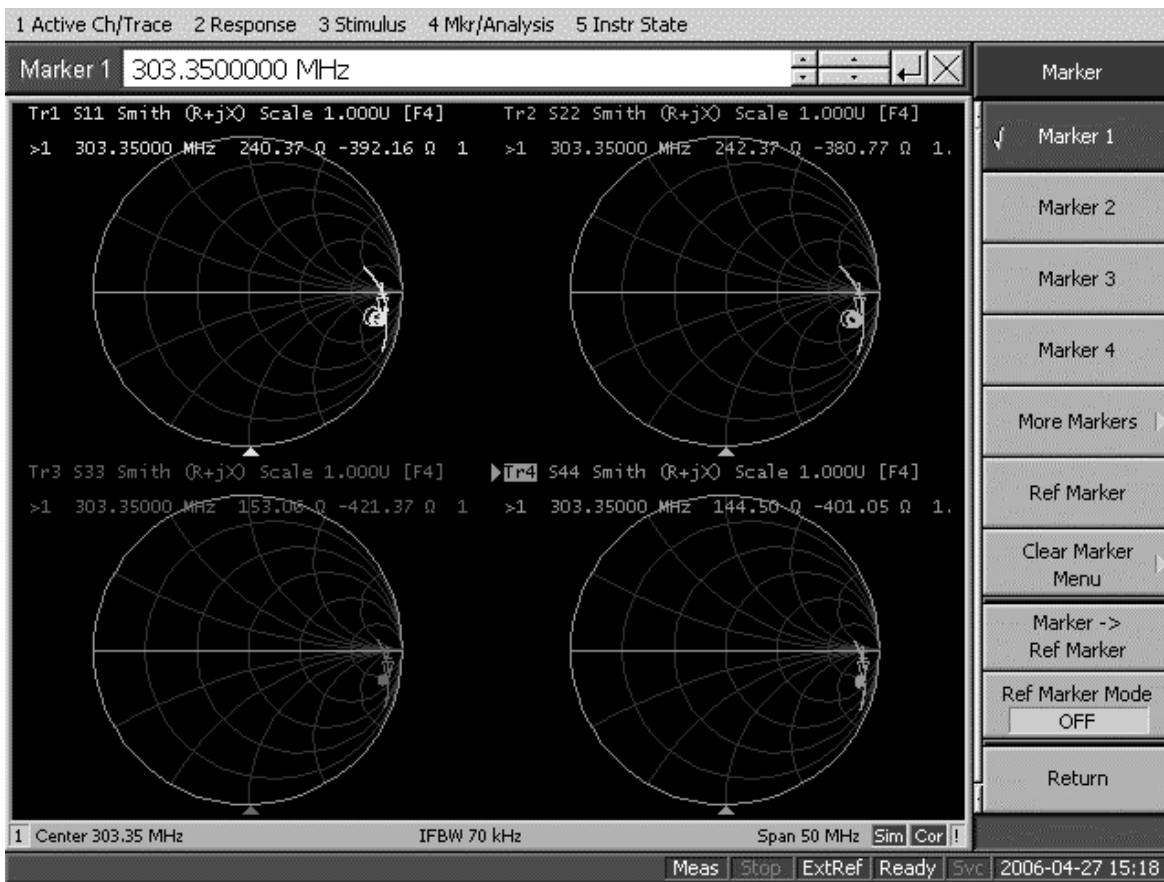

Marker

Marker 1

Marker 2

Marker 3

Marker 4

More Markers ▶

Ref Marker

Clear Marker Menu ▶

Marker -> Ref Marker

Ref Marker Mode OFF

Return

SM3838-8 Case

8-Terminal Ceramic Surface-Mount Case

3.8 X 3.8 mm Nominal Footprint

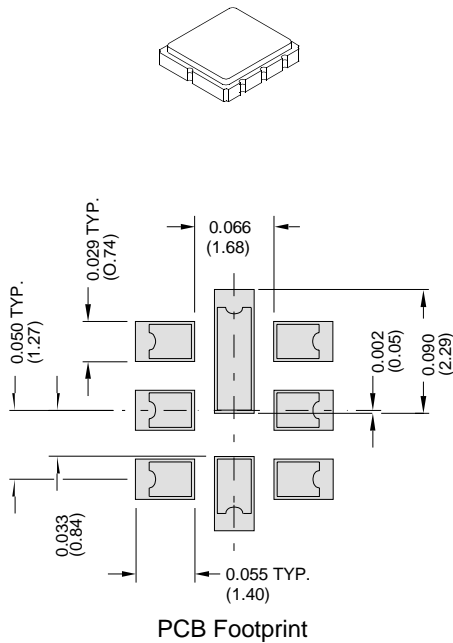

Case Dimensions						
Dimension	mm			Inches		
	Min	Nom	Max	Min	Nom	Max
A	3.6	3.8	4.0	0.142	0.150	0.157
B	3.6	3.8	4.0	0.142	0.150	0.157
C	1.05	1.20	1.35	0.041	0.047	0.053
D	0.95	1.10	1.25	0.037	0.043	0.049
E	0.90	1.00	1.10	0.035	0.040	0.043
F	0.50	0.60	0.70	0.020	0.024	0.028
G	2.39	2.54	2.69	0.090	0.100	0.110
H	1.40	1.75	2.05	0.055	0.069	0.080

Electrical Connections		
	Connection	Terminals
Port 1	Differential Input	1, 2
Port 2	Differential Output	5, 6
	Ground	All Others
Single Ended Operation		Return is Ground
Differential Operation		Return is Hot
Dot Indicates Pin 1		

Materials	
Solder Pad Termination	Au plating 30 - 60 ulnches (76.2-152 uM) over 80-200 ulnches (203-508 uM) Ni.
Lid	Fe-Ni-Co Alloy Electroless Nickel Plate (8-11% Phosphorus) 100-200 ulnches Thick
Body	Al ₂ O ₃ Ceramic
Pb Free	

TOP VIEW

BOTTOM VIEW

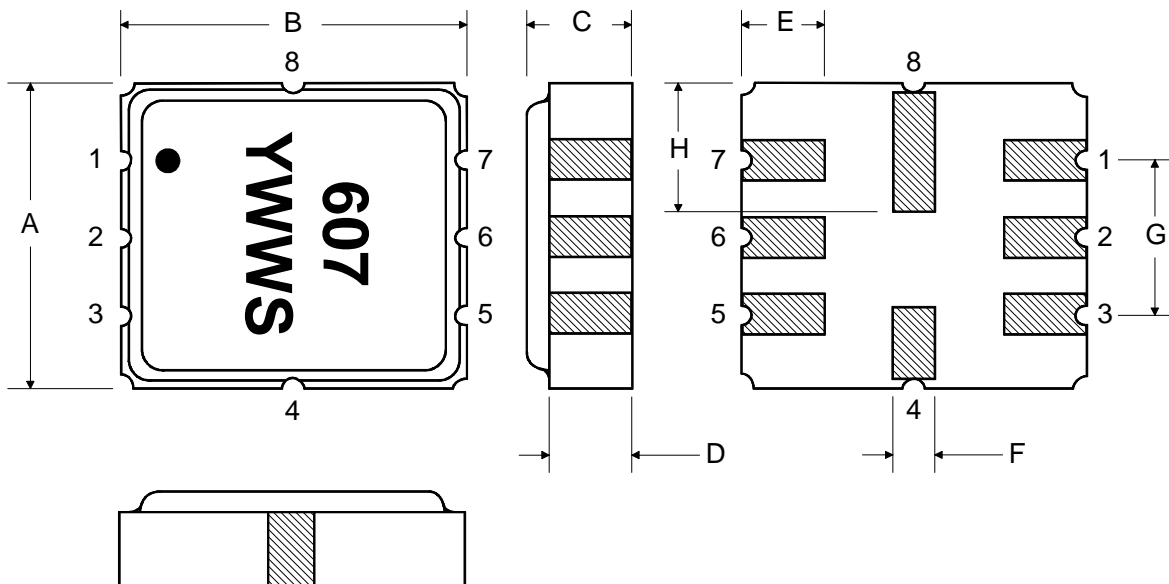

Tape and Reel Specifications

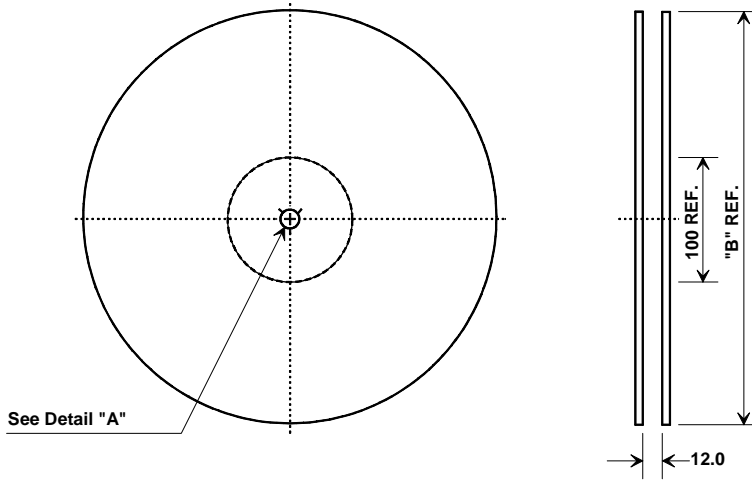

"B"		Quantity Per Reel
Inches	millimeters	
7	178	500
13	330	3000

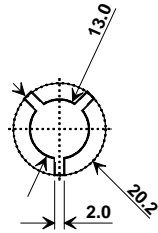

COMPONENT ORIENTATION and DIMENSIONS

Carrier Tape Dimensions	
Ao	4.25 mm
Bo	4.25 mm
Ko	1.30 mm
Pitch	8.0 mm
W	12.0 mm

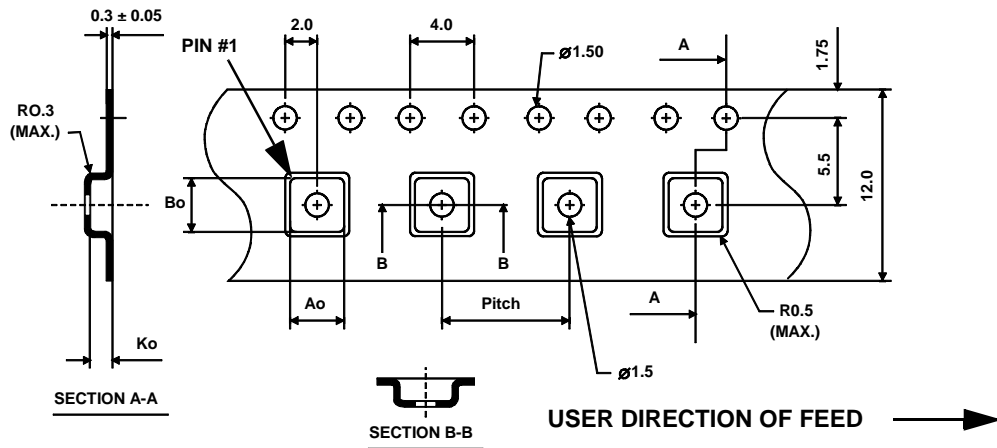



Компания «ЭлектроПласт» предлагает заключение долгосрочных отношений при поставках импортных электронных компонентов на взаимовыгодных условиях!

Наши преимущества:

- Оперативные поставки широкого спектра электронных компонентов отечественного и импортного производства напрямую от производителей и с крупнейших мировых складов;
- Поставка более 17-ти миллионов наименований электронных компонентов;
- Поставка сложных, дефицитных, либо снятых с производства позиций;
- Оперативные сроки поставки под заказ (от 5 рабочих дней);
- Экспресс доставка в любую точку России;
- Техническая поддержка проекта, помощь в подборе аналогов, поставка прототипов;
- Система менеджмента качества сертифицирована по Международному стандарту ISO 9001;
- Лицензия ФСБ на осуществление работ с использованием сведений, составляющих государственную тайну;
- Поставка специализированных компонентов (Xilinx, Altera, Analog Devices, Intersil, Interpoint, Microsemi, Aeroflex, Peregrine, Syfer, Eurofarad, Texas Instrument, Miteq, Cobham, E2V, MA-COM, Hittite, Mini-Circuits, General Dynamics и др.);

Помимо этого, одним из направлений компании «ЭлектроПласт» является направление «Источники питания». Мы предлагаем Вам помощь Конструкторского отдела:

- Подбор оптимального решения, техническое обоснование при выборе компонента;
- Подбор аналогов;
- Консультации по применению компонента;
- Поставка образцов и прототипов;
- Техническая поддержка проекта;
- Защита от снятия компонента с производства.



Как с нами связаться

Телефон: 8 (812) 309 58 32 (многоканальный)

Факс: 8 (812) 320-02-42

Электронная почта: org@eplast1.ru

Адрес: 198099, г. Санкт-Петербург, ул. Калинина, дом 2, корпус 4, литера А.