

# LCW Series Subminiature Sealed Snap-acting Switches

**NEW**



UL61058-1

## Features/Benefits

- Compact design
- Quick connect, solder terminals, PC terminals, wire leads
- Wide variety of actuator styles
- RoHS compatible, RoHS compliant
- IP67
- New generation price competitive

## Typical Applications

- Motorized equipment
- Sump pump
- Thermostatic controls
- Computers
- Air conditioners

## Specifications

CONTACT RATING: from low level to 0.1 Amp  
 ELECTRICAL LIFE: 10,000 cycles  
 INSULATION RESISTANCE: 100 M ohm min.  
 DIELECTRIC STRENGTH: 1,000 VAC  
 OPERATING TEMPERATURE:  
 -40°C to +120°C  
 OPERATING FORCE: (see ACTUATOR'S option sections).  
 MOUNTING: 2-56 screws, torque 2.3 in/lbs max.

## Materials

SWITCH HOUSING: PBT  
 SWITCH COVER: PBT  
 ACTUATOR BUTTON: PBT  
 SPRING: SUS  
 MOVABLE CONTACTS: Copper  
 STATIONARY CONTACTS: AgNi10  
 TERMINALS: Brass.  
 ACTUATOR LEVEL: SUS  
 RUBBER: Silicone

**NOTE:** Specifications and materials listed above are for switches with standard options.  
 For information on specific and custom switches, consult Customer Service center.

Snap-acting

## Build-A-Switch

To order, simply select desired option from each category and place in the appropriate box. Available options are shown and described on pages J-44 thru J-47. For additional options not shown in catalog, consult Customer Service Center.

<div style="display: flex; align-items: center; gap: 10px;"> <div style="border: 1px solid black; padding: 2px;">L</div> <div style="border: 1px solid black; padding: 2px;">C</div> <div style="border: 1px solid black; padding: 2px;">W</div> <div style="border: 1px solid black; width: 20px; height: 20px;"></div> <div style="border: 1px solid black; width: 20px; height: 20px;"></div> <div style="border: 1px solid black; width: 20px; height: 20px;"></div> <div style="border: 1px solid black; width: 20px; height: 20px;"></div> <div style="border: 1px solid black; width: 20px; height: 20px;"></div> <div style="border: 1px solid black; width: 20px; height: 20px;"></div> <div style="border: 1px solid black; width: 20px; height: 20px;"></div> </div>									
<p><b>Series</b> LCW</p>			<p><b>Operating Force</b> 2 203 grams</p>	<p><b>Circuitry</b> C SPDT W SPST N.C. Y SPST N.O.</p>					
<p><b>Electrical Rating</b></p>			<p><b>Actuator</b>                      P00 Pin plunger                      T00 12 mm short lever                      T05 17.5 mm short lever                      T07 19.5 mm short lever                      T13 25.6 mm lever                      S26 18.6 mm simulated lever</p>	<p><b>Terminations</b>                      S Solder                      Q 0.110 Quick Connect                      P PC Thru Hole                      W Wire leads potted</p>					
<table border="1"> <tr> <td>Option Code</td> <td> UL 61058-1</td> <td></td> </tr> <tr> <td>01</td> <td>0.1 A 125/250 V AC</td> <td>NA</td> </tr> </table>	Option Code	UL 61058-1		01	0.1 A 125/250 V AC	NA			
Option Code	UL 61058-1								
01	0.1 A 125/250 V AC	NA							
<p><b>Wire Side</b>                      A Wire out the bottom (check if available)                      B Wire out the right side (check if available)                      D None (Default)</p>									



NEW

# LCW Series Subminiature Sealed Snap-acting Switches

SERIES [ ][ ] [ ][ ][ ][ ][ ][ ][ ][ ][ ][ ]

LCW

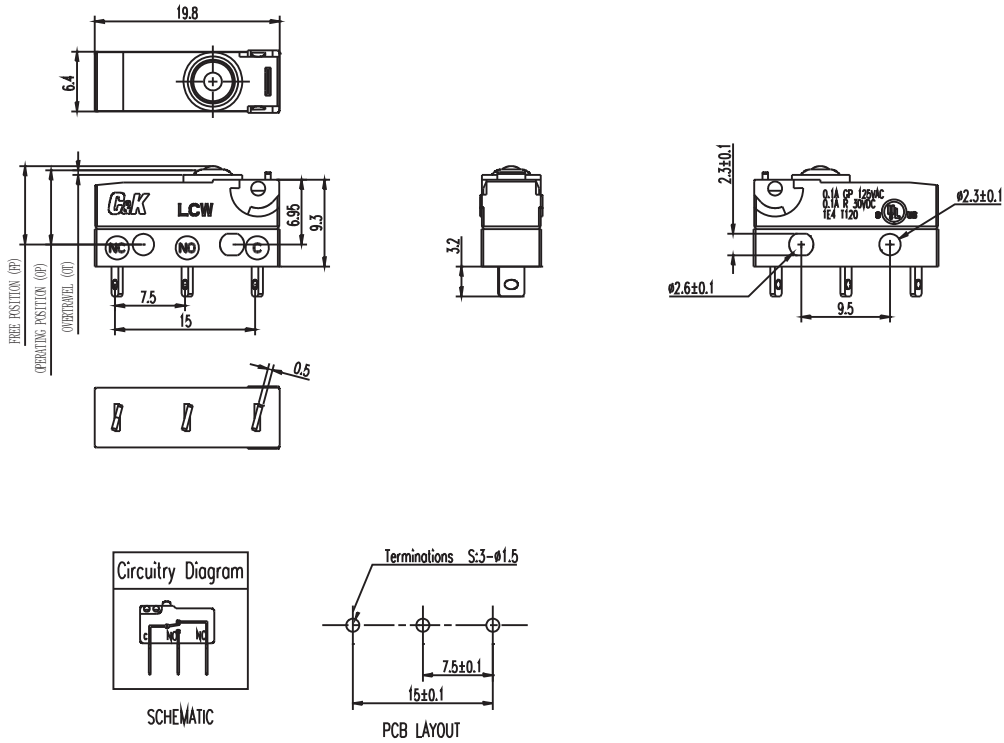

Snap-acting

## ELECTRICAL RATING [ ] [ ][ ] [ ][ ][ ][ ][ ][ ][ ][ ]

RoHS COMPLIANT *	RoHS COMPATIBLE *	OPTION CODE	ELECTRICAL RATING
YES	YES	<b>01</b>	0.1 AMP, 125/250 V AC

## OPERATING FORCE [ ][ ] [ ][ ][ ][ ][ ][ ][ ][ ][ ]

OPTION CODE	OPERATING FORCES (grams)
<b>2</b>	203 g. max.



Third Angle Projection



# LCW Series Subminiature Sealed Snap-acting Switches

**NEW**

ACTUATOR 

**P00**

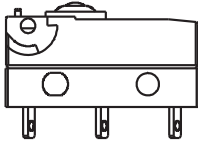

**T07**

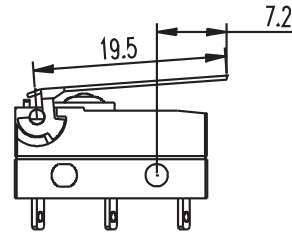

**T00**

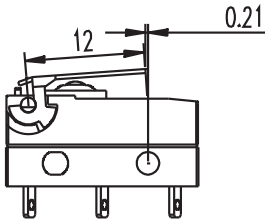

**T13**

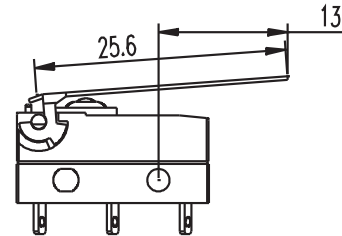

**T05**

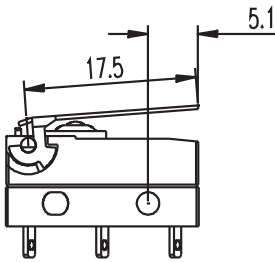

**S26**

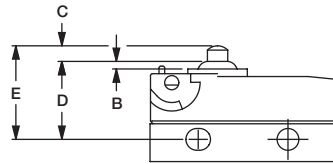
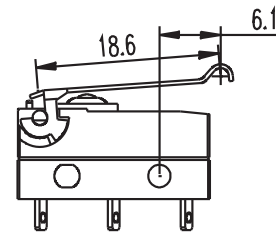

Snap-acting

Actuator Option Code	A	B	C	D	E	Differential Motion (max)	Operating Force (Max)	Release Force (Min)
	Length of Lever	Overtravel (min)	Pretravel (max)	Operating Position	Free Position (max)			
P00	Not Applicable	0.6	1	8.7±0.3	9.4	0.9	203	30
T00	12	0.6	4.9	8.8±1.2	12.5	1	100	15
T05	17.5	0.6	5.7	8.8±1.5	13	1.2	90	10
T07	19.5	0.6	6.2	8.8±1.5	13.5	1.2	70	10
T13	25.6	1	4.7	8.8-11.24	13.5	1.5	54	5
S26	18.6	0.6	4.6	10.7±1.2	14.1	1.5	68	5

Dimensions are in mm and force in grams

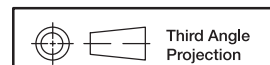

Third Angle Projection

Dimensions are shown: mm  
Specifications and dimensions subject to change



26 Feb 19

**NEW**

# LCW Series Subminiature Sealed Snap-acting Switches

## TERMINATIONS

**S** SOLDER

**Q** QUICK CONNECT 2.8mm / 0.110"

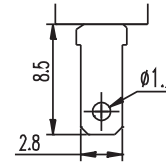
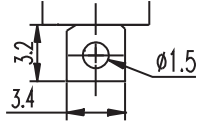

**P** PC THRU HOLE

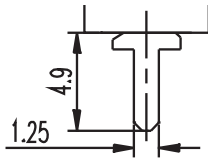

**W** "A" WIRE ORIENTATION OUT THE BOTTOM  
"W" CIRCUITRY



**W** "B" WIRE ORIENTATION OUT THE RIGHT SIDE  
"W" CIRCUITRY



**Snap-acting**

## CIRCUITRY

**C** SPDT (Single Pole, Double Throw)

**W** SPST N.C. (Single Pole, Single Throw, Normally Closed)

**Y** SPST N.O. (Single Pole, Single Throw, Normally Open)



Third Angle  
Projection

Dimensions are shown: mm  
Specifications and dimensions subject to change



26 Feb 19



Компания «ЭлектроПласт» предлагает заключение долгосрочных отношений при поставках импортных электронных компонентов на взаимовыгодных условиях!

Наши преимущества:

- Оперативные поставки широкого спектра электронных компонентов отечественного и импортного производства напрямую от производителей и с крупнейших мировых складов;
- Поставка более 17-ти миллионов наименований электронных компонентов;
- Поставка сложных, дефицитных, либо снятых с производства позиций;
- Оперативные сроки поставки под заказ (от 5 рабочих дней);
- Экспресс доставка в любую точку России;
- Техническая поддержка проекта, помощь в подборе аналогов, поставка прототипов;
- Система менеджмента качества сертифицирована по Международному стандарту ISO 9001;
- Лицензия ФСБ на осуществление работ с использованием сведений, составляющих государственную тайну;
- Поставка специализированных компонентов (Xilinx, Altera, Analog Devices, Intersil, Interpoint, Microsemi, Aeroflex, Peregrine, Syfer, Eurofarad, Texas Instrument, Miteq, Cobham, E2V, MA-COM, Hittite, Mini-Circuits, General Dynamics и др.);

Помимо этого, одним из направлений компании «ЭлектроПласт» является направление «Источники питания». Мы предлагаем Вам помощь Конструкторского отдела:

- Подбор оптимального решения, техническое обоснование при выборе компонента;
- Подбор аналогов;
- Консультации по применению компонента;
- Поставка образцов и прототипов;
- Техническая поддержка проекта;
- Защита от снятия компонента с производства.



#### Как с нами связаться

**Телефон:** 8 (812) 309 58 32 (многоканальный)

**Факс:** 8 (812) 320-02-42

**Электронная почта:** [org@eplast1.ru](mailto:org@eplast1.ru)

**Адрес:** 198099, г. Санкт-Петербург, ул. Калинина, дом 2, корпус 4, литера А.