

## Surface Mount Transformers/Inductors, Gapped and Ungapped Custom Configurations Available

**ELECTRICAL SPECIFICATIONS**

Inductance Range: 10  $\mu$ H to 47 000  $\mu$ H, measured at 0.10 V RMS at 10 kHz without DC current, using an HP 4263A or HP 4284A impedance analyzer

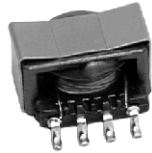

DC Resistance Range: 0.03  $\Omega$  to 19.1  $\Omega$ , measured at +25 °C  $\pm$  5 °C

**RoHS COMPLIANT**

Rated Current Range: 2.00 amps to 0.09 amps

Dielectric Withstanding Voltage: 500 V RMS, 60 Hz, 5 seconds

**DIMENSIONS** in inches [millimeters]

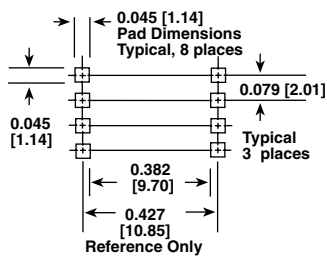
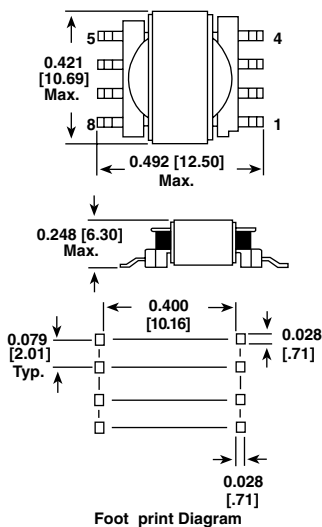
**Pad Layout**

**Dimensional Outline**

**NOTE:** Pad layout guidelines per MIL-STD-275E (printed wiring for electronic equipment). Tolerances: xx  $\pm$  0.01" [ $\pm$  0.25 mm]; xxx  $\pm$  0.005" [ $\pm$  0.12 mm]

The underside of these components contains metal and thus should not come in contact with active circuit traces.

**STANDARD ELECTRICAL SPECIFICATIONS**

MODEL	IND. ( $\mu$ H)	IND. TOL.	SCHEMATIC LETTER	DCR MAX. (Ohms)	MAX. RATED* DC CURRENT (Amps)	SATURATING CURRENT** (Amps)
<b>Ungapped Models (A)</b>						
LPE4841ER101NU	100	$\pm$ 30 %	A	0.17	0.88	N/A
LPE4841ER151NU	150	$\pm$ 30 %	A	0.21	0.79	N/A
LPE4841ER221NU	220	$\pm$ 30 %	A	0.25	0.721	N/A
LPE4841ER331NU	330	$\pm$ 30 %	A	0.30	0.65	N/A
LPE4841ER471NU	470	$\pm$ 30 %	A	0.36	0.60	N/A
LPE4841ER681NU	680	$\pm$ 30 %	A	0.44	0.54	N/A
LPE4841ER102NU	1000	$\pm$ 30 %	A	0.53	0.49	N/A
LPE4841ER152NU	1500	$\pm$ 30 %	A	0.65	0.45	N/A
LPE4841ER222NU	2200	$\pm$ 30 %	A	0.79	0.40	N/A
LPE4841ER332NU	3300	$\pm$ 30 %	A	1.55	0.29	N/A
LPE4841ER472NU	4700	$\pm$ 30 %	A	1.85	0.26	N/A
LPE4841ER682NU	6800	$\pm$ 30 %	A	4.36	0.17	N/A
LPE4841ER103NU	10 000	$\pm$ 30 %	A	5.29	0.16	N/A
LPE4841ER153NU	15 000	$\pm$ 30 %	A	6.48	0.14	N/A
LPE4841ER223NU	22 000	$\pm$ 30 %	A	13.1	0.10	N/A
LPE4841ER333NU	33 000	$\pm$ 30 %	A	16.0	0.09	N/A
LPE4841ER473NU	47 000	$\pm$ 30 %	A	19.1	0.08	N/A
<b>Gapped Models (B)</b>						
LPE4841ER100MG	10	$\pm$ 20 %	B	0.03	2.03	2.320
LPE4841ER150MG	15	$\pm$ 20 %	B	0.04	1.84	1.925
LPE4841ER220MG	22	$\pm$ 20 %	C	0.07	1.32	1.610
LPE4841ER330MG	33	$\pm$ 20 %	C	0.09	1.20	1.330
LPE4841ER470MG	47	$\pm$ 20 %	D	0.13	0.98	1.125
LPE4841ER680MG	68	$\pm$ 20 %	D	0.21	0.79	0.941
LPE4841ER101MG	100	$\pm$ 20 %	E	0.35	0.58	0.781
LPE4841ER151MG	150	$\pm$ 20 %	E	0.48	0.52	0.641
LPE4841ER221MG	220	$\pm$ 20 %	E	0.73	0.42	0.532
LPE4841ER331MG	330	$\pm$ 20 %	E	1.14	0.34	0.436
LPE4841ER471MG	470	$\pm$ 20 %	E	1.36	0.31	0.366
LPE4841ER681MG	680	$\pm$ 20 %	E	2.07	0.25	0.305
LPE4841ER102MG	1000	$\pm$ 20 %	E	3.15	0.20	0.252
LPE4841ER152MG	1500	$\pm$ 20 %	E	4.76	0.16	0.206
LPE4841ER222MG	2200	$\pm$ 20 %	E	7.29	0.13	0.170
LPE4841ER332MG	3300	$\pm$ 20 %	E	11.7	0.11	0.139
LPE4841ER472MG	4700	$\pm$ 20 %	E	17.7	0.09	0.117

\* DC current that will create a maximum temperature rise of 30 °C when applied at +25 °C ambient. \*\* DC current that will typically reduce the initial inductance by 20 %.

**UNGAPPED MODELS:** Highest possible inductance with the lowest DCR and highest Q capability. Beneficial in filter, impedance matching and line coupling devices.

**GAPPED MODELS:** Capable of handling large amounts of DC current, tighter inductance tolerance with better temperature stability than ungapped models. Beneficial in DC to DC converters or other circuits carrying DC currents or requiring inductance stability over a temperature range.

**DESCRIPTION**

LPE 4841 1000  $\mu$ H  $\pm$  30 % A ER e2  
 MODEL SIZE INDUCTANCE VALUE INDUCTANCE TOLERANCE CORE PACKAGE CODE JEDEC LEAD (Pb)-FREE STANDARD

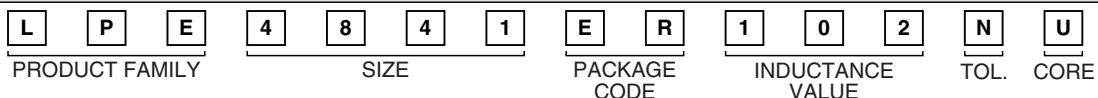
**GLOBAL PART NUMBER**

NOTE Series is also available with SnPb terminations by using package code RY for tape and reel (in place of ER) or SM for bulk (in place of EB).

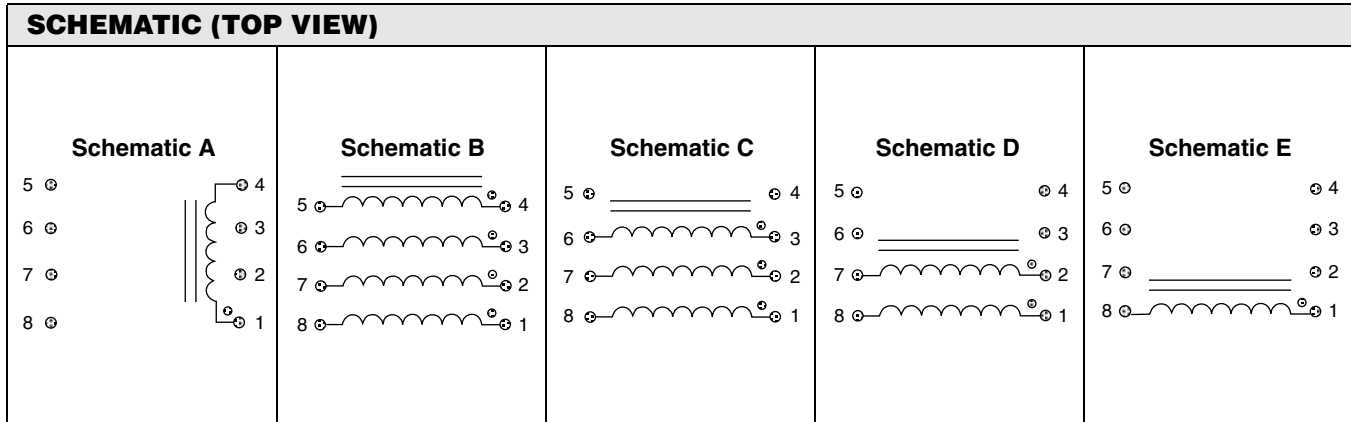

**NOTE:** Schematic A is for Ungapped LPE Series

ENVIRONMENTAL PERFORMANCE	
TEST	CONDITIONS
Thermal Cycling	Withstands - 55 °C to + 125 °C
Operating Temperature	- 55 °C to + 125 °C*
High Humidity	85 %
Soldering Heat	Tested to + 230 °C
Mechanical Shock	Per MIL-STD-202, Method 213 (100G)
Vibration	Per MIL-STD-202, Method 204 (20G)
Solderability	Per industry standards

\* Must be checked in end use application

PART MARKING
- Vishay Dale
- Date code
- Marking code (Suffix of model #)
- Pin 1 indicator

**PACKAGING**

**TAPE SPECIFICATIONS:**

Carrier Tape Type: Conductive  
Cover Tape Type: Anti-static  
Cover Tape Adhesion to Carrier: 40 ± 30 grams

**REEL SPECIFICATIONS:**

Diameter (flange): 13" [330.2 mm]  
Maximum Width (over flanges): 1.197" [30.4 mm]

**STANDARDS:** All embossed carrier tape packaging will be accomplished in compliance with latest revision of EIA-481 Taping of Surface Mount Components for Automatic Placement".

MODEL	TAPE WIDTH	COMPONENT PITCH	UNITS PER 13 INCH REEL
LPE-4841	24 mm	16 mm	600

**Tape and Reel Orientation**

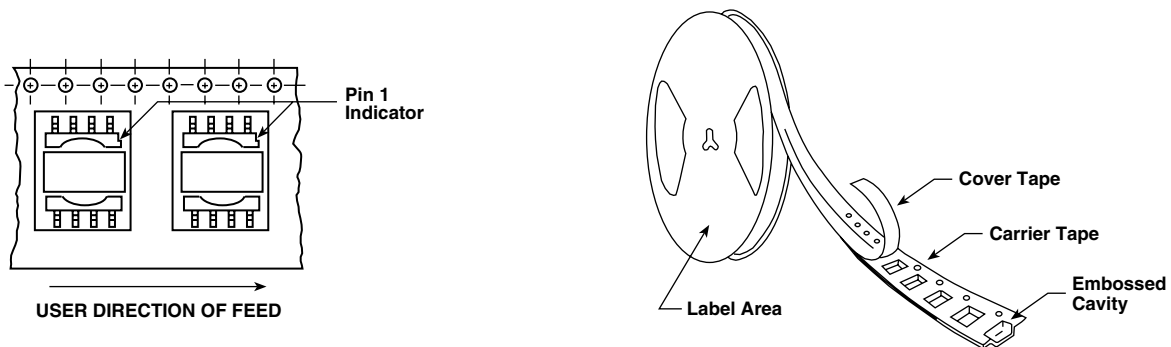

**NOTE:** Top view shown with cover tape removed



## Disclaimer

All product specifications and data are subject to change without notice.

Vishay Intertechnology, Inc., its affiliates, agents, and employees, and all persons acting on its or their behalf (collectively, "Vishay"), disclaim any and all liability for any errors, inaccuracies or incompleteness contained herein or in any other disclosure relating to any product.

Vishay disclaims any and all liability arising out of the use or application of any product described herein or of any information provided herein to the maximum extent permitted by law. The product specifications do not expand or otherwise modify Vishay's terms and conditions of purchase, including but not limited to the warranty expressed therein, which apply to these products.

No license, express or implied, by estoppel or otherwise, to any intellectual property rights is granted by this document or by any conduct of Vishay.

The products shown herein are not designed for use in medical, life-saving, or life-sustaining applications unless otherwise expressly indicated. Customers using or selling Vishay products not expressly indicated for use in such applications do so entirely at their own risk and agree to fully indemnify Vishay for any damages arising or resulting from such use or sale. Please contact authorized Vishay personnel to obtain written terms and conditions regarding products designed for such applications.

Product names and markings noted herein may be trademarks of their respective owners.



Компания «ЭлектроПласт» предлагает заключение долгосрочных отношений при поставках импортных электронных компонентов на взаимовыгодных условиях!

Наши преимущества:

- Оперативные поставки широкого спектра электронных компонентов отечественного и импортного производства напрямую от производителей и с крупнейших мировых складов;
- Поставка более 17-ти миллионов наименований электронных компонентов;
- Поставка сложных, дефицитных, либо снятых с производства позиций;
- Оперативные сроки поставки под заказ (от 5 рабочих дней);
- Экспресс доставка в любую точку России;
- Техническая поддержка проекта, помощь в подборе аналогов, поставка прототипов;
- Система менеджмента качества сертифицирована по Международному стандарту ISO 9001;
- Лицензия ФСБ на осуществление работ с использованием сведений, составляющих государственную тайну;
- Поставка специализированных компонентов (Xilinx, Altera, Analog Devices, Intersil, Interpoint, Microsemi, Aeroflex, Peregrine, Syfer, Eurofarad, Texas Instrument, Miteq, Cobham, E2V, MA-COM, Hittite, Mini-Circuits, General Dynamics и др.);

Помимо этого, одним из направлений компании «ЭлектроПласт» является направление «Источники питания». Мы предлагаем Вам помощь Конструкторского отдела:

- Подбор оптимального решения, техническое обоснование при выборе компонента;
- Подбор аналогов;
- Консультации по применению компонента;
- Поставка образцов и прототипов;
- Техническая поддержка проекта;
- Защита от снятия компонента с производства.



#### Как с нами связаться

**Телефон:** 8 (812) 309 58 32 (многоканальный)

**Факс:** 8 (812) 320-02-42

**Электронная почта:** [org@eplast1.ru](mailto:org@eplast1.ru)

**Адрес:** 198099, г. Санкт-Петербург, ул. Калинина, дом 2, корпус 4, литера А.