



FCIconnect.com

Copyright FCI.

List of "SFV__R-1/2STBE1HLF" customer document

| DOCUMENT NO. | LIST |
|--------------|---|
| SC-SFV08 | SPEC. |
| JSA 97501 | CAT.NO.TABLE FOR 0.5mm CONTACT SPACING CONNECTOR (SFV__R-1/2STB_HLF) |
| JSA 97502 | CONNECTOR USED FOR FPC/FFC WITH 0.5mm CONTACT SPACING (SFV__R-1STB_HLF) |
| JSA 97503 | CONNECTOR USED FOR FPC/FFC WITH 0.5mm CONTACT SPACING (SFV__R-2STB_HLF) |
| JSA 97504 | CAT.NO.TABLE FOR PLASTIC TAPE PACKAGED 0.5mm CONTACT SPACING CONNECTOR (SFV__R-1/2STBE1HLF) |
| JSA 97505 | PLASTIC TAPE PACKAGED 0.5mm CONTACT SPACING CONNECTOR (SFV__R-1STBE1HLF) |
| JSA 97506 | PLASTIC TAPE PACKAGED 0.5mm CONTACT SPACING CONNECTOR (SFV__R-2STBE1HLF) |
| JSA96019 | RECOMMENDED CABLE (FPC) (SFV__R-1/2ST__LF) |
| JSA97202 | RECOMMENDED CABLE (FFC) (SFV__R-1/2ST__) |
| BUM-SFV101 | HANDLING PROCEDURES |

| | | | | | | | | | | | | | |
|-------------|--|--------------------|--|---|--|--|--|---------------------------------------|--|--|--|--------------|--|
| mat'l. code | | | | surface ISO 1302 <input checked="" type="checkbox"/> | | tolerance ISO 406 <input type="checkbox"/> ISO 1101 <input type="checkbox"/> | | projection | | product family 58EF | | CODE JP | |
| ltr A | | ecn no J09-0075 | | dr S.W | | date '09/2/19 | | tolerances unless otherwise specified | | title 0.5mm SPACING FPC CONNECTOR DOCUMENT LIST (Cat. No. : SFV__R-1/2STBE1HLF) | | | |
| | | | | angles | | linear | | mm | | | | | |
| | | | | dr <i>S. Watanabe</i> | | 2009-2-19 | | | | dwg no | | sheet 1 of 1 | |
| | | | | enr <i>S. Watanabe</i> | | 2009-2-19 | | | | JSA 97500 | | size A4 | |
| | | | | chr <i>M. YAMAUCHI</i> | | 2009-2-19 | | | | type Product Customer Drawing | | | |
| sheet index | | revision sheet | | A | | 1 | | | | | | Rev A | |

CAT. NO. & DIMENSIONS

| NO. OF CONTACTS (n) | CAT. NO. | DIMENSIONS (NOTE2) | | | |
|---------------------|--------------------|--------------------|---------|---------|---------|
| | | A ± 0.2 | B ± 0.2 | C ± 0.1 | D ± 0.1 |
| 4 | SFV4R-1/2STB__HLF | 7.5 | 5.9 | 1.5 | 2.7 |
| 5 | SFV5R-1/2STB__HLF | 8.0 | 6.4 | 2.0 | 3.2 |
| 6 | SFV6R-1/2STB__HLF | 8.5 | 6.9 | 2.5 | 3.7 |
| 7 | SFV7R-1/2STB__HLF | 9.0 | 7.4 | 3.0 | 4.2 |
| 8 | SFV8R-1/2STB__HLF | 9.5 | 7.9 | 3.5 | 4.7 |
| 9 | SFV9R-1/2STB__HLF | 10.0 | 8.4 | 4.0 | 5.2 |
| 10 | SFV10R-1/2STB__HLF | 10.5 | 8.9 | 4.5 | 5.7 |
| 11 | SFV11R-1/2STB__HLF | 11.0 | 9.4 | 5.0 | 6.2 |
| 12 | SFV12R-1/2STB__HLF | 11.5 | 9.9 | 5.5 | 6.7 |
| 13 | SFV13R-1/2STB__HLF | 12.0 | 10.4 | 6.0 | 7.2 |
| 14 | SFV14R-1/2STB__HLF | 12.5 | 10.9 | 6.5 | 7.7 |
| 15 | SFV15R-1/2STB__HLF | 13.0 | 11.4 | 7.0 | 8.2 |
| 16 | SFV16R-1/2STB__HLF | 13.5 | 11.9 | 7.5 | 8.7 |
| 17 | SFV17R-1/2STB__HLF | 14.0 | 12.4 | 8.0 | 9.2 |
| 18 | SFV18R-1/2STB__HLF | 14.5 | 12.9 | 8.5 | 9.7 |
| 19 | SFV19R-1/2STB__HLF | 15.0 | 13.4 | 9.0 | 10.2 |
| 20 | SFV20R-1/2STB__HLF | 15.5 | 13.9 | 9.5 | 10.7 |
| 21 | SFV21R-1/2STB__HLF | 16.0 | 14.4 | 10.0 | 11.2 |
| 22 | SFV22R-1/2STB__HLF | 16.5 | 14.9 | 10.5 | 11.7 |
| 23 | SFV23R-1/2STB__HLF | 17.0 | 15.4 | 11.0 | 12.2 |
| 24 | SFV24R-1/2STB__HLF | 17.5 | 15.9 | 11.5 | 12.7 |
| 25 | SFV25R-1/2STB__HLF | 18.0 | 16.4 | 12.0 | 13.2 |
| 26 | SFV26R-1/2STB__HLF | 18.5 | 16.9 | 12.5 | 13.7 |
| 27 | SFV27R-1/2STB__HLF | 19.0 | 17.4 | 13.0 | 14.2 |
| 28 | SFV28R-1/2STB__HLF | 19.5 | 17.9 | 13.5 | 14.7 |
| 29 | SFV29R-1/2STB__HLF | 20.0 | 18.4 | 14.0 | 15.2 |
| 30 | SFV30R-1/2STB__HLF | 20.5 | 18.9 | 14.5 | 15.7 |
| 31 | SFV31R-1/2STB__HLF | 21.0 | 19.4 | 15.0 | 16.2 |
| 32 | SFV32R-1/2STB__HLF | 21.5 | 19.9 | 15.5 | 16.7 |
| 33 | SFV33R-1/2STB__HLF | 22.0 | 20.4 | 16.0 | 17.2 |
| 34 | SFV34R-1/2STB__HLF | 22.5 | 20.9 | 16.5 | 17.7 |
| 35 | SFV35R-1/2STB__HLF | 23.0 | 21.4 | 17.0 | 18.2 |



NOTES

1. THIS PRODUCT IS THE CONNECTOR USED FOR FPC AND COPEs WITH AUTOMATIC MOUNTING (SMT).
2. SEE PART DRAWINGS FOR DIMENSIONS A~D.



FCIconnect.com

Copyright FCI.

| | | | | | | | | | | | |
|-------------|----------------|--|----------|---|---------------------------------------|------------|---------|-------------------------------|---|-------------------|--|
| mat'l. code | | surface ISO 1302 <input checked="" type="checkbox"/> | | tolerance ISO 406 <input checked="" type="checkbox"/> | | projection | | product family 58EF | | CODE JP | |
| ltr | ecn no | dr | date | | tolerances unless otherwise specified | | mm | | title | | |
| A | J09-0075 | S.W | '09/2/19 | | angles linear | | scale X | | CAT. NO. TABLE FOR 0.5 mm CONTACT SPACING CONNECTOR (Cat. No. : SFV__R-1/2STB__HLF) | | |
| dr | | engr | | chr | | appd | | dwg no | | sheet 1 of 1 size | |
| S. Nithin | | S. Nithin | | H. VAMPISRETA | | J. Madan | | JSA 97501 | | A4 | |
| 2009-2-19 | | 2009-2-19 | | 2009-2-19 | | 2009-2-19 | | type Product Customer Drawing | | | |
| sheet index | revision sheet | A 1 | | Rev. A | | | | | | | |



FCIconnect.com

Copyright FCI.



| PT. NO. | PARTS NAME | MATERIAL | Q'TY | NOTE |
|---------|----------------|--|------|------------------------------|
| 1 | HOUSING | 13~35pin : LCP RESIN GLASS REINFORCED (UL94V-0) | 1 | COLOR : BLACK (HALOGEN FREE) |
| | | 4~12pin : POLYAMIDE RESIN GLASS REINFORCED (UL94V-0) | | |
| 2 | SLIDER | PPS RESIN GLASS REINFORCED (UL94V-0) | 1 | COLOR : BLACK (HALOGEN FREE) |
| 3 | CONTACT | PHOSPHOR BRONZE | n | PLATING : GOLD |
| 4 | MOUNTING PLATE | | 2 | PLATING : LEAD FREE |

RECOMMENDED PC BOARD LAYOUT (COMPONENT SIDE)

PATTERN FOR MOUNTING PLATE FIXING

n : NO. OF CONTACTS



NOTES

1. THIS PRODUCT IS THE CONNECTOR USED FOR FPC AND COPE WITH AUTOMATIC MOUNTING (SMT).
2. THIS PRODUCT IS LOWER CONTACT TYPE CONNECTOR.
3. FLATNESS OF CONTACT TERMINAL AND MOUNTING PLATE MUST BE WITHIN TOLERANCE IN E PORTION DETAILED DRAWING.
4. THIS PRODUCT MEETS EUROPEAN UNION DIRECTIVES AND OTHER COUNTRY REGULATIONS AS DESCRIBED IN GS-22-008.
5. THE HOUSING WILL WITHSTAND EXPOSURE TO 260°C PEAK TEMPERATURE FOR 10 SECONDS IN A REFLOW SOLDERING OVEN.

| | | | | | | |
|-------------|----------|---------------------------------------|-------------------------------|------------|---|------|
| mat'l. code | | surface | tolerance | projection | product family | CODE |
| | | ISO 1302 ✓ | ISO 406 | | 58EF | JP |
| | | tolerances unless otherwise specified | | mm | title | |
| ltr | ecn no | dr | date | | CONNECTOR USED FOR FPC WITH 0.5 mm CONTACT SPACING (Cat No. : SFV__R-1STB__HLF) | |
| A | J09-0075 | S.W | 2009-2-19 | scale X | dwg no | |
| B | J10-0245 | S.W | 2010-9-14 | | sheet 1 of 1 size | |
| | | angles | linear | | JSA 97502 | |
| | | dr | <i>S. Nishida</i> 2010-9-14 | | type Product Customer Drawing | |
| | | enrg | <i>S. Nishida</i> 2010-9-14 | | Rev. B | |
| | | chr | <i>M. Yamashita</i> 2010-9-14 | | | |
| | | appd | <i>M. Yamashita</i> Sep16'10 | | | |
| sheet index | revision | B | | | | |
| | sheet | 1 | | | | |

form: A4



| PT. NO. | PARTS NAME | MATERIAL | Q'TY | NOTE |
|---------|----------------|--|------|------------------------------|
| 1 | HOUSING | 13~35pin : LCP RESIN GLASS REINFORCED (UL94V-0) | 1 | COLOR : BLACK (HALOGEN FREE) |
| | | 4~12pin : POLYAMIDE RESIN GLASS REINFORCED (UL94V-0) | | |
| 2 | SLIDER | PPS RESIN GLASS REINFORCED (UL94V-0) | 1 | COLOR : BLACK (HALOGEN FREE) |
| 3 | CONTACT | PHOSPHOR BRONZE | n | PLATING : GOLD |
| 4 | MOUNTING PLATE | | 2 | PLATING : LEAD FREE |

RECOMMENDED PC BOARD LAYOUT
(COMPONENT SIDE)

PATTERN FOR MOUNTING PLATE FIXING

n : NO. OF CONTACTS



- NOTES
- THIS PRODUCT IS THE CONNECTOR USED FOR FPC AND COPER WITH AUTOMATIC MOUNTING (SMT).
 - THIS PRODUCT IS UPPER CONTACT TYPE CONNECTOR.
 - FLATNESS OF CONTACT TERMINAL AND MOUNTING PLATE MUST BE WITHIN TOLERANCE IN E PORTION DETAILED DRAWING.
 - THIS PRODUCT MEETS EUROPEAN UNION DIRECTIVES AND OTHER COUNTRY REGULATIONS AS DESCRIBED IN GS-22-008.
 - THE HOUSING WILL WITHSTAND EXPOSURE TO 260°C PEAK TEMPERATURE FOR 10 SECONDS IN A REFLOW SOLDERING OVEN.

| | | | | | | | | |
|-------------|----------------|-----|-----------|---------------------------------------|----------------------------------|----------------|--|---------------------|
| mat'l. code | | | | surface ISO 1302 ✓ | tolerance ISO 406 ISO 1101 | projection | product family 58EF | CODE JP |
| ltr | ecn no | dr | date | tolerances unless otherwise specified | | mm | title CONNECTOR USED FOR FPC WITH 0.5 mm CONTACT SPACING (Cat. No. : SFV__R-2STB__HLF) | |
| A | J09-0075 | S.W | 2009-2-19 | angles | linear | | scale X | dwg no JSA 97503 |
| B | J10-0245 | S.W | 2010-9-14 | | | | type Product Customer Drawing | |
| | | | | dr | S. Nishida 2010-9-14 | | dwg no sheet 1 of 1 size A4 | |
| | | | | enr | S. Nishida 2010-9-14 | | type Product Customer Drawing | |
| | | | | chr | M. Yamashita 2010-9-14 | | | |
| | | | | app | M. Yamashita 2010-9-14 | | | |
| sheet index | revision sheet | B | 1 | | | | | Rev. B |

form: A4

1

2

CAT. NO. & DIMENSIONS

| NO. OF CONTACTS (n) | CAT. NO. | DIMENSIONS (NOTE3) | | |
|---------------------|--------------------|--------------------|---------|---------|
| | | F ± 5 | G ± 0.3 | H ± 0.1 |
| 4 | SFV4R-1/2STBE1HLF | 20.4 | 16 | — |
| 5 | SFV5R-1/2STBE1HLF | 20.4 | 16 | — |
| 6 | SFV6R-1/2STBE1HLF | 20.4 | 16 | — |
| 7 | SFV7R-1/2STBE1HLF | 28.4 | 24 | — |
| 8 | SFV8R-1/2STBE1HLF | 28.4 | 24 | — |
| 9 | SFV9R-1/2STBE1HLF | 28.4 | 24 | — |
| 10 | SFV10R-1/2STBE1HLF | 28.4 | 24 | — |
| 11 | SFV11R-1/2STBE1HLF | 28.4 | 24 | — |
| 12 | SFV12R-1/2STBE1HLF | 28.4 | 24 | — |
| 13 | SFV13R-1/2STBE1HLF | 28.4 | 24 | — |
| 14 | SFV14R-1/2STBE1HLF | 28.4 | 24 | — |
| 15 | SFV15R-1/2STBE1HLF | 28.4 | 24 | — |
| 16 | SFV16R-1/2STBE1HLF | 28.4 | 24 | — |
| 17 | SFV17R-1/2STBE1HLF | 28.4 | 24 | — |
| 18 | SFV18R-1/2STBE1HLF | 28.4 | 24 | — |
| 19 | SFV19R-1/2STBE1HLF | 28.4 | 24 | — |
| 20 | SFV20R-1/2STBE1HLF | 28.4 | 24 | — |
| 21 | SFV21R-1/2STBE1HLF | 28.4 | 24 | — |
| 22 | SFV22R-1/2STBE1HLF | 28.4 | 24 | — |
| 23 | SFV23R-1/2STBE1HLF | 36.4 | 32 | 28.4 |
| 24 | SFV24R-1/2STBE1HLF | 36.4 | 32 | 28.4 |
| 25 | SFV25R-1/2STBE1HLF | 36.4 | 32 | 28.4 |
| 26 | SFV26R-1/2STBE1HLF | 36.4 | 32 | 28.4 |
| 27 | SFV27R-1/2STBE1HLF | 36.4 | 32 | 28.4 |
| 28 | SFV28R-1/2STBE1HLF | 36.4 | 32 | 28.4 |
| 29 | SFV29R-1/2STBE1HLF | 36.4 | 32 | 28.4 |
| 30 | SFV30R-1/2STBE1HLF | 36.4 | 32 | 28.4 |
| 31 | SFV31R-1/2STBE1HLF | 48.4 | 44 | 40.4 |
| 32 | SFV32R-1/2STBE1HLF | 48.4 | 44 | 40.4 |
| 33 | SFV33R-1/2STBE1HLF | 48.4 | 44 | 40.4 |
| 34 | SFV34R-1/2STBE1HLF | 48.4 | 44 | 40.4 |
| 35 | SFV35R-1/2STBE1HLF | 48.4 | 44 | 40.4 |



NOTES

1. THIS PRODUCT IS THE CONNECTOR USED FOR FPC AND COPEs WITH AUTOMATIC MOUNTING (SMT).
2. THIS CATALOG NO. INDICATES PLASTIC TAPE PACKAGED CONNECTOR.
3. SEE PART DRAWINGS FOR DIMENSIONS F~H.



FCIconnect.com

Copyright FCI.

| | | | | | | | | | | | |
|-------------|--|--------------------|--|----------------------------|--|---------------|--|---|--|-------------------------------|--|
| mat'l. code | | surface ISO 1302 ✓ | | tolerance ISO 406 ISO 1101 | | projection | | product family 58EF | | CODE JP | |
| ltr A | | ecn no J09-0075 | | dr S.W | | date '09/2/19 | | title | | sheet 1 of 1 | |
| | | | | angles linear | | mm | | CAT. NO. TABLE FOR PLASTIC TAPE PACKAGED 0.5 mm CONTACT SPACING CONNECTOR (Cat. No. : SFV__R-1/2STBE1HLF) | | size A4 | |
| | | | | dr S. Nishida 2009-2-19 | | | | scale X | | dwg no JSA 97504 | |
| | | | | enr S. Nishida 2009-2-19 | | | | FCI | | type Product Customer Drawing | |
| | | | | chr H. YAMASHITA 2009-2-19 | | | | | | Rev. A | |
| | | | | appd J. Chokran 2009-2-19 | | | | | | A | |
| sheet index | | revision sheet | | A 1 | | | | | | | |



| PT. NO. | PARTS NAME | CAT. NO. | MATERIAL | Q'TY | NOTE |
|---------|-----------------------|------------------|-------------------|-------|----------------------|
| 1 | REEL | _____ | CARDBOARD | 1 | COLOR : WHITE |
| 2 | PLASTIC (EMBOSS) TAPE | _____ | A-PET | _____ | COLOR : TRANSPARENCY |
| 3 | COVER | _____ | POLYESTER | _____ | COLOR : TRANSPARENCY |
| 4 | CONNECTOR | SFV__R-1STB__HLF | SEE ATTACHED DWG. | 3000 | LOWER CONTACT TYPE |

- NOTES
1. THIS IS PLASTIC TAPE PACKAGED CONNECTOR USED FOR FPC AND COPES WITH AUTOMATIC MOUNTING (SMT).
 2. SEE JIS C 0806 (PACKING OF ELECTRONIC COMPONENTS ON CONTINUOUS TAPES (SURFACE MOUNTING DEVICES)) FOR SHAPE AND DIMENSIONS OF PLASTIC (EMBOSS) TAPE AND REEL.
 3. F DIMENSION IS PORTION OF THE CORE.

| | | | | | | | | | |
|-------------|--|--|--|----------------------|--|-------------------------------|--|---------------------------------------|--|
| mat'l. code | | surface 58 / tolerance ISO 1302 / ISO 406 / ISO 1101 | | projection | | product family 58EF | | CODE JP | |
| ltr A | | ecn no J09-0075 | | dr S.W | | date '09/2/19 | | tolerances unless otherwise specified | |
| | | angles ±5' | | linear | | mm | | title | |
| | | dr | | engr | | chr | | appd | |
| | | S. Nishida 2009-2-19 | | S. Nishida 2009-2-19 | | M. YAMAHATA 2009-2-19 | | S. Okada 2009-2-19 | |
| | | scale X | | FCJ | | dwg no JSA 97505 | | sheet 1 of 1 size A4 | |
| sheet index | | revision A | | sheet 1 | | type Product Customer Drawing | | Rev. A | |



| PT. NO. | PARTS NAME | CAT. NO. | MATERIAL | Q'TY | NOTE |
|---------|-----------------------|------------------|-------------------|-------|----------------------|
| 1 | REEL | _____ | CARDBOARD | 1 | COLOR : WHITE |
| 2 | PLASTIC (EMBOSS) TAPE | _____ | A-PET | _____ | COLOR : TRANSPARENCY |
| 3 | COVER | _____ | POLYESTER | _____ | COLOR : TRANSPARENCY |
| 4 | CONNECTOR | SFV__R-2STB__HLF | SEE ATTACHED DWG. | 3000 | UPPER CONTACT TYPE |

NOTES

- THIS IS PLASTIC TAPE PACKAGED CONNECTOR USED FOR FPC AND COPEs WITH AUTOMATIC MOUNTING (SMT).
- SEE JIS C 0806 (PACKING OF ELECTRONIC COMPONENTS ON CONTINUOUS TAPES (SURFACE MOUNTING DEVICES)) FOR SHAPE AND DIMENSIONS OF PLASTIC (EMBOSS) TAPE AND REEL.
- F DIMENSION IS PORTION OF THE CORE.

| | | | | | | | | | | | |
|-------------|----------------|--|---------------------|---|--------|------------|--|--|--|-------------------------------|--|
| mat'l. code | | surface ISO 1302 <input checked="" type="checkbox"/> | | tolerance ISO 406 <input checked="" type="checkbox"/> | | projection | | product family 58EF | | CODE JP | |
| ltr | ecn no | dr | date | tolerances, unless otherwise specified | | mm | | title PLASTIC TAPE PACKAGED 0.5 mm CONTACT SPACING CONNECTOR (Cat. No. : SFV__R-2STBE1HLF) | | | |
| A | J09-0075 | S.W | '09/2/19 | angles | linear | ±5 | | scale X | | dwg no sheet 1 of 1 size | |
| | | | | ±5' | | | | | | JSA 97506 A4 | |
| | | dr | <i>S. Yamashita</i> | | | | | | | type Product Customer Drawing | |
| | | enr | <i>S. Yamashita</i> | | | | | | | Rev. A | |
| | | chr | <i>M. YAMASHITA</i> | | | | | | | | |
| | | appd | <i>S. Yamashita</i> | | | | | | | | |
| sheet index | revision sheet | A | 1 | | | | | | | | |



Copyright FCI.



RECOMMENDED CABLE (FPC)

n : NO. OF CONTACTS

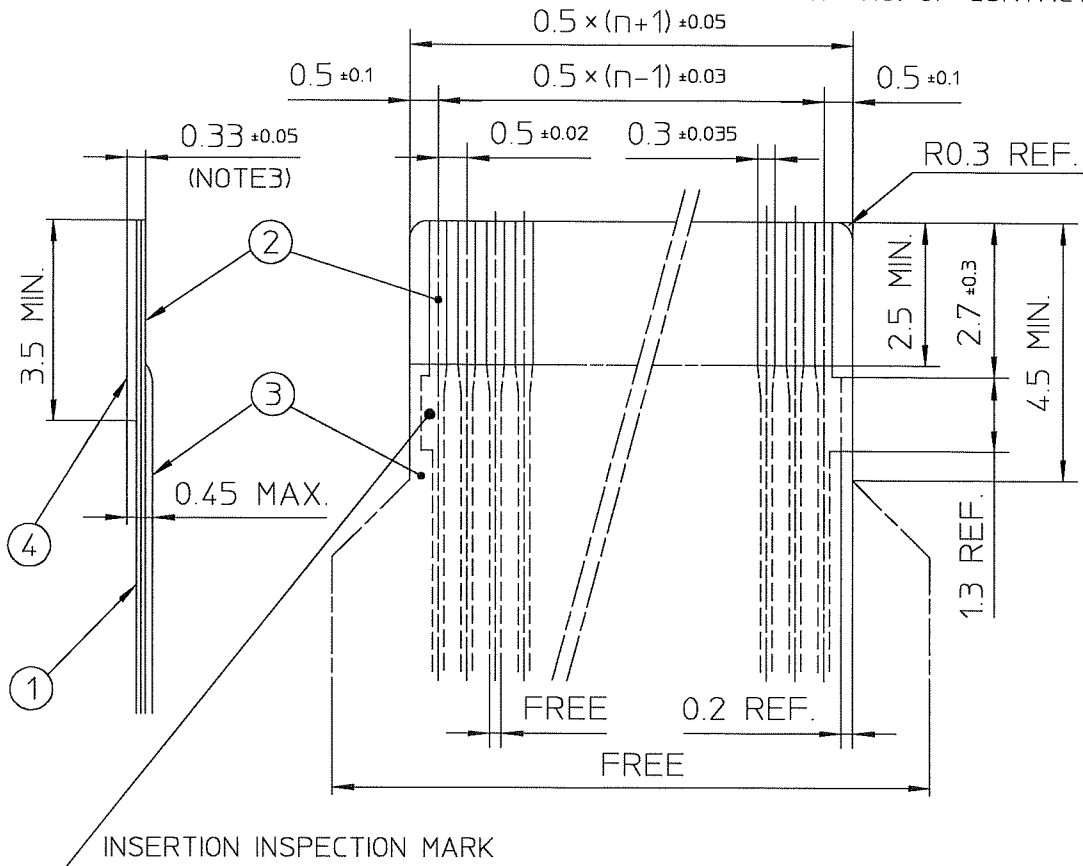

| PT. NO. | PARTS NAME | MATERIAL | THICKNESS(μm) |
|---------|-----------------|---------------------------------|---------------|
| 1 | BASE FILM | POLYIMIDE OR POLYESTER OR EQUAL | 25 |
| 2 | CONDUCTOR | COPPER FOIL(PLATING : GOLD) | 35 |
| 3 | OVERLAY | POLYIMIDE OR POLYESTER OR EQUAL | — |
| 4 | SUPPORTING TAPE | POLYESTER OR POLYIMIDE OR EQUAL | 188 |

NOTES

1. NO BURR AT EACH PORTION.
2. NO PEELING IN COMMON USE.
3. TOTAL THICKNESS LIMIT OF EACH MATERIAL (INCLUDING ADHESIVE AGENT) IS SPECIFIED.

| | | | | | | | | | |
|-------------------------------|----------|-----|----------|---------------------------------------|----------------------------|------------|---|--------|--------------|
| mat'l. code | | | | surface ISO 1302 ✓ | tolerance ISO 406 ISO 1101 | projection | product family 58EF | | |
| ltr | ecn no | dr | date | tolerances unless otherwise specified | | | title RECOMMENDED CABLE (Cat. No. : SFV__R-1/2ST__LF) | | |
| A | J04-0186 | H.T | '04/8/19 | angles linear | | | | | |
| B | J04-0454 | H.T | '05/2/17 | | | | | | |
| C | J06-0372 | H.T | '06/9/17 | dr | | 9/7/06 | | dwg no | sheet 1 of 1 |
| | | | | enr | 9/7/06 | JSA 96019 | | A4 | |
| | | | | chr | 9/8/06 | | | | |
| | | | | appd | 9/11/06 | | | | |
| type Product Customer Drawing | | | | | | | | | |

| | | | | | | | | | | | | | | | | | | |
|-------------|----------------|---|---|--|--|--|--|--|--|--|--|--|--|--|--|--|--|--------|
| sheet index | revision sheet | C | 1 | | | | | | | | | | | | | | | Rev. C |
|-------------|----------------|---|---|--|--|--|--|--|--|--|--|--|--|--|--|--|--|--------|

SC-SFV06 JSA96013 form: A4



FCJconnect.com

Copyright FCJ

RECOMMENDED CABLE (FFC)

n : NO. OF CONTACTS



| KIND OF FFC (NOTE3) | DIMENSIONAL TOLERANCE | | | |
|---------------------|-----------------------|-------|-------|--------|
| | a | b | c | d |
| 1 | ±0.07 | ±0.04 | ±0.05 | ±0.02 |
| 2 | ±0.1 | ±0.03 | ±0.03 | ±0.025 |

| PT. NO. | PARTS NAME | MATERIAL |
|---------|-----------------|------------------------------------|
| 1 | INSULATOR | FLAME RESISTING POLYESTER OR EQUAL |
| 2 | CONDUCTOR | COPPER FOIL (PLATING : GOLD) |
| 3 | SUPPORTING TAPE | FLAME RESISTING POLYESTER OR EQUAL |

NOTES

- NO BURR AT EACH PORTION.
- NO PEELING IN COMMON USE.
- EITHER KIND1 OR KIND2 OF FFC CAN ACCEPT DIMENSIONAL TOLERANCE a,b,c AND d.

| | | | | | | | | | | |
|-------------|----------------|-----|----------|---------------------------------------|-----------------------------|----------------|---|--|--------------|--------|
| mat'l. code | | | | surface ISO 1302 ✓ | tolerance ISO 406 ISO 1101 | projection | product family 58EF | | | |
| ltr | ecn no | dr | date | tolerances unless otherwise specified | | scale \times | title | | | |
| A | J06-0499 | H.T | 11/27/06 | angles | linear | | RECOMMENDED CABLE (Cat. No. : SFV__R-1/2ST__) | | | |
| | | | | dr | <i>[Signature]</i> 11/27/06 | | dwg no | | sheet 1 of 1 | size |
| | | | | enr | <i>[Signature]</i> 11/27/06 | | JSA 97202 | | | A4 |
| | | | | chr | <i>[Signature]</i> 11/27/06 | | type Product Customer Drawing | | | |
| | | | | appd | <i>[Signature]</i> 11/28/06 | | | | | |
| sheet index | revision sheet | A | 1 | | | | | | | Rev. A |



FCJconnect.com

Copyright FCJ



Компания «ЭлектроПласт» предлагает заключение долгосрочных отношений при поставках импортных электронных компонентов на взаимовыгодных условиях!

Наши преимущества:

- Оперативные поставки широкого спектра электронных компонентов отечественного и импортного производства напрямую от производителей и с крупнейших мировых складов;
- Поставка более 17-ти миллионов наименований электронных компонентов;
- Поставка сложных, дефицитных, либо снятых с производства позиций;
- Оперативные сроки поставки под заказ (от 5 рабочих дней);
- Экспресс доставка в любую точку России;
- Техническая поддержка проекта, помощь в подборе аналогов, поставка прототипов;
- Система менеджмента качества сертифицирована по Международному стандарту ISO 9001;
- Лицензия ФСБ на осуществление работ с использованием сведений, составляющих государственную тайну;
- Поставка специализированных компонентов (Xilinx, Altera, Analog Devices, Intersil, Interpoint, Microsemi, Aeroflex, Peregrine, Syfer, Eurofarad, Texas Instrument, Miteq, Cobham, E2V, MA-COM, Hittite, Mini-Circuits, General Dynamics и др.);

Помимо этого, одним из направлений компании «ЭлектроПласт» является направление «Источники питания». Мы предлагаем Вам помощь Конструкторского отдела:

- Подбор оптимального решения, техническое обоснование при выборе компонента;
- Подбор аналогов;
- Консультации по применению компонента;
- Поставка образцов и прототипов;
- Техническая поддержка проекта;
- Защита от снятия компонента с производства.



Как с нами связаться

Телефон: 8 (812) 309 58 32 (многоканальный)

Факс: 8 (812) 320-02-42

Электронная почта: org@eplast1.ru

Адрес: 198099, г. Санкт-Петербург, ул. Калинина, дом 2, корпус 4, литера А.