



Future Technology Devices International Ltd

USB to RS232 UART Serial Converter PCB

Datasheet

Document Reference No.: FT_000079

Version 1.41

Issue Date: 2011-01-26

Future Technology Devices International Limited (FTDI)

Unit1, 2 Seaward Place, Centurion Business Park, Glasgow G41 1HH United Kingdom

Tel.: +44 (0) 141 429 2777 Fax: + 44 (0) 141 429 2758

E-Mail (Support): support1@ftdichip.com Web: <http://www.ftdichip.com>

Copyright © 2011 Future Technology Devices International Limited

Neither the whole nor any part of the information contained in, or the product described in this manual, may be adapted or reproduced in any material or electronic form without the prior written consent of the copyright holder. This product and its documentation are supplied on an as-is basis and no warranty as to their suitability for any particular purpose is either made or implied. Future Technology Devices International Ltd will not accept any claim for damages howsoever arising as a result of use or failure of this product. Your statutory rights are not affected. This product or any variant of it is not intended for use in any medical appliance, device or system in which the failure of the product might reasonably be expected to result in personal injury. This document provides preliminary information that may be subject to change without notice. No freedom to use patents or other intellectual property rights is implied by the publication of this document. Future Technology Devices International Ltd, Unit1, 2 Seaward Place, Centurion Business Park, Glasgow, G41 1HH, United Kingdom. Scotland Registered Number: SC136640

1 Description

The **USB-RS232-PCB** is a USB to RS232 level serial UART converter PCB incorporating FTDI's FT232RQ USB to Serial UART interface IC device which handles all the USB signalling and protocols. The PCB provides a fast, simple way to connect devices with a RS232 level serial interface to USB.

Each USB-RS232-PCB contains a small internal electronic circuit board, utilising the FT232R plus a USB type-A connector. The FT232R datasheet, DS_FT232R, is available at <http://www.ftdichip.com>. The integrated electronics also include an RS232 level shifter plus Tx and Rx LEDs which give a visual indication of UART traffic. All components used, including the FT232R are Pb-free (RoHS compliant).

The PCB is USB powered and USB 2.0 full speed compatible. Each PCB supports a data transfer rate up to 1 Mbaud and supports the FTDIChip-ID™, with a unique USB serial number programmed into the FT232R. This feature can be used to create a security or password protected file transfer access using the PCB. Further information and examples on this feature are available at <http://www.ftdichip.com> under FTDIChip-ID Projects.

The USB-RS232-PCB requires USB drivers, available free from <http://www.ftdichip.com>, which are used to make the FT232R on the PCB appear as a virtual COM port (VCP). This then allows the user to communicate with the USB interface via a standard PC serial emulation port (for example TTY). Another FTDI USB driver, the D2XX driver, can also be used with application software to directly access the FT232R on the PCB through a DLL. This is illustrated in the Figure 1.1.

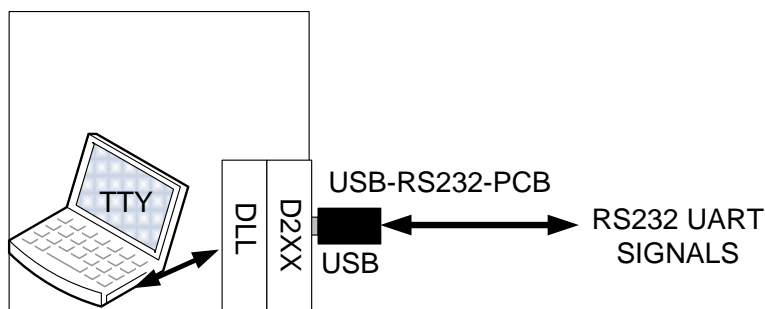
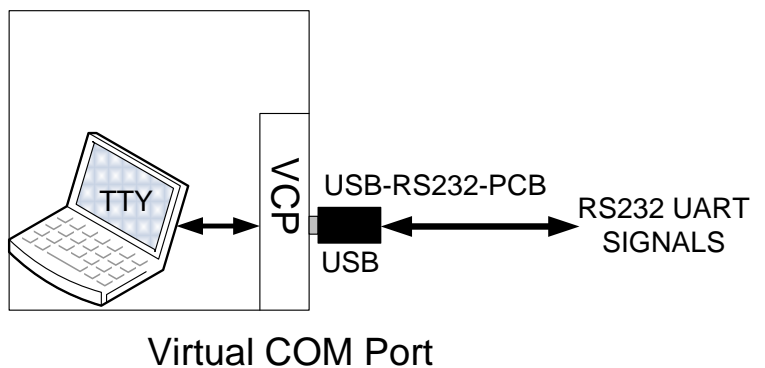

Software application access to USB via D2XX

Figure 1.1 Using the USB-RS232-PCB

1.1 Part Number

The following Table 1.1 gives details of the available USB-RS232-PCB.

Part Number	Description
USB-RS232-PCB	USB to RS232 level UART PCB

Table 1.1 USB-RS232-PCB Part Number

1.2 USB Compliant

The USB-RS232-PCB is fully compliant with the USB 2.0 specification.



Table of Contents

1	Description	1
1.1	Part Number.....	1
1.2	USB Compliant	2
	The USB-RS232-PCB is fully compliant with the USB 2.0 specification.	2
2	Typical Applications.....	4
2.1	Driver Support	4
2.2	Features.....	5
3	Features of FT232R applicable to USB-RS232-PCB	6
4	USB-RS232-PCB Connector Pin Out and Mechanical details	7
4.1	USB-RS232-PCB Signal Descriptions	9
4.2	USB-RS232-PCB +5V/+3.3V Selection	9
4.3	USB-RS232-PCB Electrical Parameters	10
5	USB-RS232-PCB Circuit Schematic	11
6	Contact Information	12
	Appendix A - PCB EEPROM Configuration	13
	Appendix B - List of Figures and Tables.....	14
	Appendix C - Revision History	15

2 Typical Applications

- USB to Serial RS232 Level Converter.
- Upgrading Legacy Peripherals to USB.
- Interface Microcontroller UART or I/O to USB.
- Interface FPGA / PLD to USB.
- USB Instrumentation PC interface.
- USB Industrial Control.
- USB password protected file transfers.

2.1 Driver Support

Royalty free VIRTUAL COM PORT (VCP) DRIVERS for...

- Windows 98, 98SE, ME, 2000, Server 2003, XP and Server 2008
- Windows XP and XP 64-bit
- Windows Vista and Vista 64-bit
- Windows XP Embedded
- Windows CE 4.2, 5.0 and 6.0
- Mac OS 8/9, OS-X
- Linux 2.4 and greater

Royalty free D2XX *Direct Drivers* (USB Drivers + DLL S/W Interface)

- Windows 98, 98SE, ME, 2000, Server 2003, XP and Server 2008
- Windows XP and XP 64-bit
- Windows Vista and Vista 64-bit
- Windows XP Embedded
- Windows CE 4.2, 5.0 and 6.0
- Linux 2.4 and greater
- Mac OS-X

The drivers listed above are all available to download for free from www.ftdichip.com. Various 3rd Party Drivers are also available for various other operating systems - see www.ftdichip.com for details.

2.2 Features

- USB-RS232-PCB provides a USB to RS232 Serial UART interface.
- Entire USB protocol handled by the electronics on the PCB.
- EIA/TIA-232 and V.28/V.24 communication interface with low power requirements.
- UART interface support for 7 or 8 data bits, 1 or 2 stop bits and odd / even / mark / space / no parity.
- Fully assisted hardware (RTS#/CTS#) or X-On / X-Off software handshaking.
- Data transfer rates up to 1 Mbaud.
- Internal EEPROM with user writeable area.
- FTDI's royalty-free VCP allow for communication as a standard emulated COM port and D2XX 'direct' drivers provide DLL application programming interface.
- Support for FT232R FTDIChip-ID™ feature for improved security.
- PCB is USB Powered - no external supply required.
- 6 outputs provide Tx, Rx, RTS#, CTS#, POWER and GND.
- Low USB bandwidth consumption.
- UHCI / OHCI / EHCI host controller compatible.
- USB 2.0 Full Speed compatible.
- -40°C to +85°C operating temperature range.
- ESD Protection for RS-232 I/O's
 - ±15kV Human Body Model (HBM)
 - ±15kV EN61000-4-2 Air Gap Discharge
 - ±8kV EN61000-4-2 Contact Discharge

3 Features of FT232R applicable to USB-RS232-PCB

The USB-RS232-PCB uses FTDI's FT232RQ USB to serial IC device. This section summarises the key features of the FT232RQ which apply to the USB-RS232-PCB. For further details, and a full features and enhancements description consult the FT232R datasheet, this is available from www.ftdichip.com.

Internal EEPROM. The internal EEPROM is used to store USB Vendor ID (VID), Product ID (PID), device serial number, product description string and various other USB configuration descriptors. Each FT232RQ is supplied with the internal EEPROM pre-programmed as described in **Appendix A - PCB EEPROM Configuration**. The internal EEPROM descriptors can be programmed in circuit, over USB without any additional voltage requirement. It can be programmed using the FTDI utility software called MPROG, which can be downloaded from FTDI Utilities on the FTDI website (www.ftdichip.com). Additionally, there is a user area of the internal EEPROM available to system designers to allow storing of data (note that this is not modified by MPROG).

Lower Operating and Suspend Current. The FT232R has a low 15mA operating supply current and a very low USB suspend current of approximately 70µA.

Low USB Bandwidth Consumption. The USB interface of the FT232R, and therefore the USB-RS232-PCB has been designed to use as little as possible of the total USB bandwidth available from the USB host controller.

UART Pin Signal Inversion. The sense of each of the UART signals can be individually inverted by configuring options in the internal EEPROM. For example CTS# (active low) can be changed to CTS (active high), or TXD can be changed to TXD#.

FTDICHIP-ID™. The FT232R includes the new FTDICHIP-ID™ security dongle feature. This FTDICHIP-ID™ feature allows a unique number to be burnt into each FT_232RQ during manufacture. This number cannot be reprogrammed. This number is only readable over USB can be used to form the basis of a security dongle which can be used to protect any customer application software being copied. This allows the possibility of using the USB-RS232-PCB as a dongle for software licensing. Further to this, a renewable license scheme can be implemented based on the FTDICHIP-ID™ number when encrypted with other information. This encrypted number can be stored in the user area of the FT232R internal EEPROM, and can be decrypted, then compared with the protected FTDICHIP-ID™ to verify that a license is valid. Web based applications can be used to maintain product licensing this way. An application note, AN232R-02, available from FTDI website (www.ftdichip.com) describes this feature.

Extended Operating Temperature Range - The USB-RS232-PCB is capable of operating over an extended temperature range of -40° to +85°C thus allowing it to be used in automotive or industrial applications.

4 USB-RS232-PCB Connector Pin Out and Mechanical details

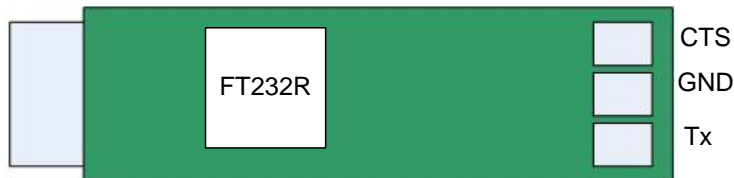
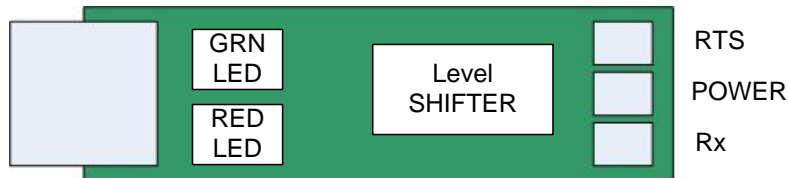

USB-RS232-PCB Rev 1

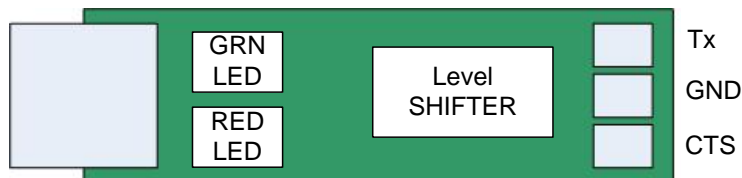

USB-RS232-PCB Rev 2

Figure 4.1 USB-RS232-PCB Pin Out (Top is TOP View, Bottom is BOTTOM View)

Changes made from Rev1 to Rev 2 design:

- Pad designation changed between Rev1 and Rev2 (see Figure 4.1)
- R1 doesn't exist in Rev2 design, the selection of power signal is done using either R2 (+3.3V) or R3 (+5V), (see Table 4.2)
- The LEDTX, LEDRX, PWREN and SLEEP are connected to the FT232R differently (see schematic)

The mechanical details of the PCB are shown in the following diagram Figure 4.2

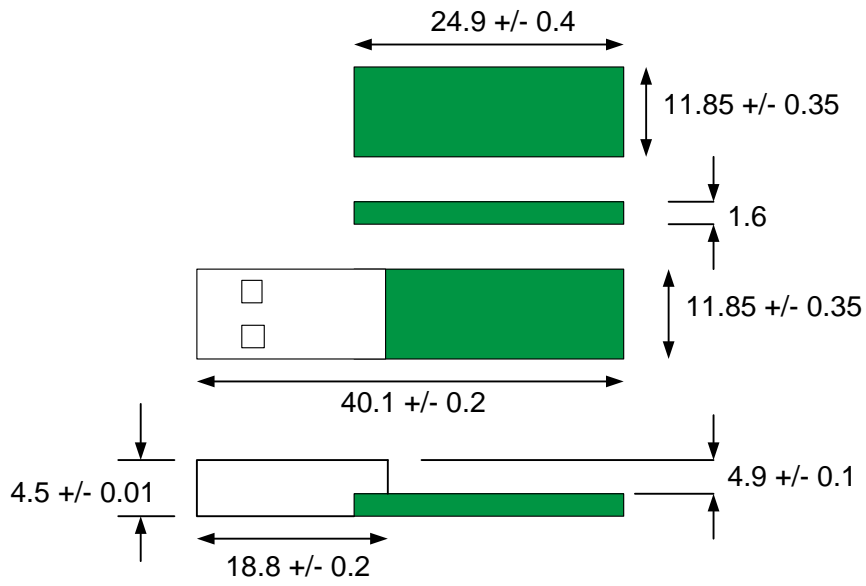

Dimensions in mm

Figure 4.2 USB-RS232-PCB, Mechanical Details

4.1 USB-RS232-PCB Signal Descriptions

Name	Type	Description
GND	GND	Device ground supply pin.
CTS#	Input	Clear to Send Control input / Handshake signal.
POWER	Output	Power output. Default is GND, but can be customised to output +3.3V or +5V. If required, contact FTDI Sales Team (sales1@ftdichip.com)
TXD	Output	Transmit Asynchronous Data output.
RXD	Input	Receive Asynchronous Data input.
RTS#	Output	Request To Send Control Output / Handshake signal.

Table 4.1 USB-RS232-PCB Signal Descriptions

4.2 USB-RS232-PCB +5V/+3.3V Selection

Selection of whether the POWER signal is GND, +3.3V or +5V is done using resistors. The following table gives details of what resistors are required for the different voltage levels.

Resistor R2	Resistor R3	Description
Not Fitted	Not Fitted	VCC floats
Fitted	Not Fitted	POWER Signal is +3.3V
Not Fitted	Fitted	POWER Signal is +5.0V

Table 4.2 UART Signal Level Selection

4.3 USB-RS232-PCB Electrical Parameters

Parameter	Description	Minimum	Typical	Maximum	Units	Conditions
VCC_5V	Output Power Voltage*	4.25	5.0*	5.25	V	*Default is GND. This figure only applies when cable has been customised to output +5V. The range is dependent on the USB port that the USB-RS232-WE is connected to
VCC_3.3V	Output Power Voltage**	3.2	3.3**	3.4	V	**Default is GND. This figure only applies when cable has been customised to output +3.3V.
I _o	Output Power Current***	-		75	mA	***Only applies when POWER output is customised to +5V or +3.3V Must be less than 2.5mA during suspend.
T	Operating Temperature Range	-40		+85	°C	

Table 4.3 USB-RS232-PCB

Parameter	Description	Minimum	Typical	Maximum	Units	Conditions
V _{trans}	RS232 Transmitter output voltage swing	+/- 5	+/- 6.5	+/- 15	V	
V _{rec}	RS232 Receiver input voltage range	-25		+25	V	

Table 4.4 USB-RS232-PCB I/O Pin Characteristics

Description	Conditions	Minimum	Typical	Maximum
ESD HBM	RS-232 Inputs and Outputs		±15 kV	
EN61000-4-2ContactDischarge	RS-232 Inputs and Outputs		±8 kV	
EN61000-4-2AirGapDischarge	RS-232 Inputs and Outputs		±15 kV	

Table 4.5 USB-RS232-WE ESD Tolerance

5 USB-RS232-PCB Circuit Schematic

The circuit schematic of the USB-RS232-PCB, utilising the FTDI FT232R, is shown in Figure 5.1

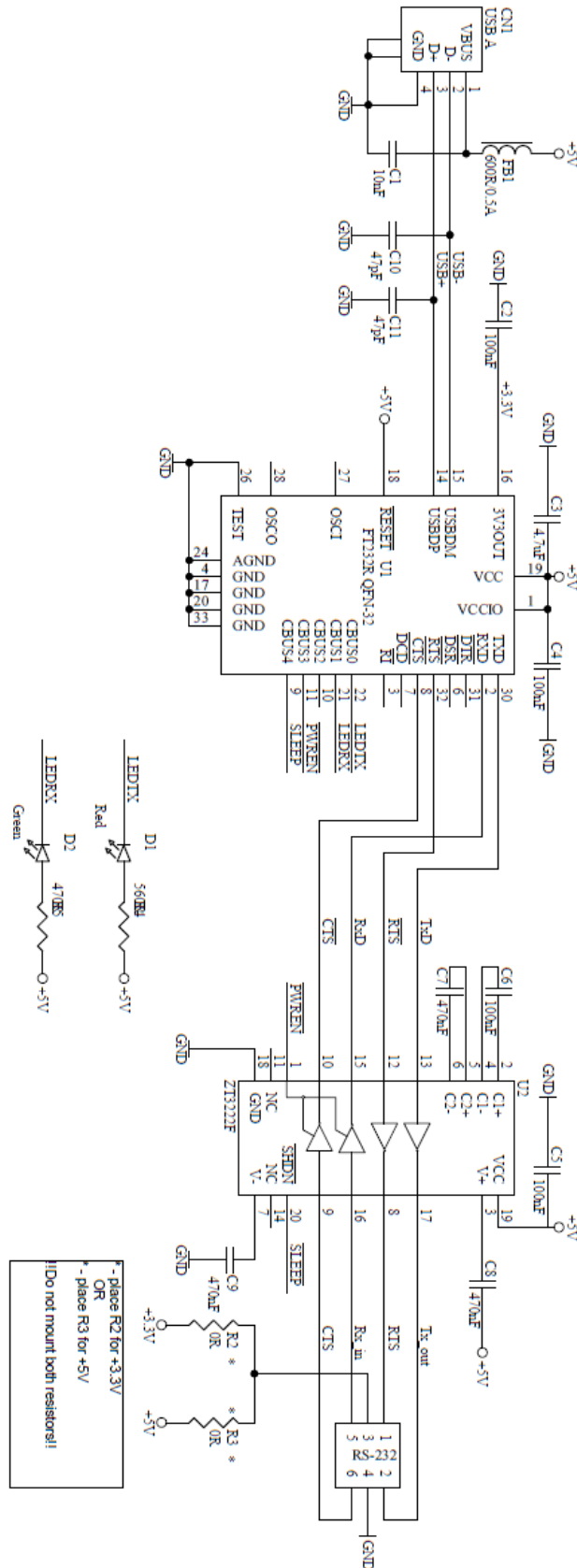

Figure 5.1 Circuit Schematic of USB-RS232-PCB.

6 Contact Information

Head Office – Glasgow, UK

Future Technology Devices International Limited
Unit 1, 2 Seaward Place, Centurion Business Park
Glasgow G41 1HH
United Kingdom
Tel: +44 (0) 141 429 2777
Fax: +44 (0) 141 429 2758

E-mail (Sales) sales1@ftdichip.com
E-mail (Support) support1@ftdichip.com
E-mail (General Enquiries) admin1@ftdichip.com
Web Site URL <http://www.ftdichip.com>
Web Shop URL <http://www.ftdichip.com>

Branch Office – Taipei, Taiwan

Future Technology Devices International Limited
(Taiwan)
2F, No. 516, Sec. 1, NeiHu Road
Taipei 114
Taiwan, R.O.C.
Tel: +886 (0) 2 8791 3570
Fax: +886 (0) 2 8791 3576

E-mail (Sales) tw.sales1@ftdichip.com
E-mail (Support) tw.support1@ftdichip.com
E-mail (General Enquiries) tw.admin1@ftdichip.com
Web Site URL <http://www.ftdichip.com>

Branch Office – Hillsboro, Oregon, USA

Future Technology Devices International Limited
(USA)
7235 NW Evergreen Parkway, Suite 600
Hillsboro, OR 97123-5803
USA
Tel: +1 (503) 547 0988
Fax: +1 (503) 547 0987

E-Mail (Sales) us.sales@ftdichip.com
E-Mail (Support) us.support@ftdichip.com
E-Mail (General Enquiries) us.admin@ftdichip.com
Web Site URL <http://www.ftdichip.com>

Branch Office – Shanghai, China

Future Technology Devices International Limited
(China)
Room 408, 317 Xianxia Road,
Shanghai, 200051
China
Tel: +86 21 62351596
Fax: +86 21 62351595

E-mail (Sales) cn.sales@ftdichip.com
E-mail (Support) cn.support@ftdichip.com
E-mail (General Enquiries) cn.admin@ftdichip.com
Web Site URL <http://www.ftdichip.com>

Distributor and Sales Representatives

Please visit the Sales Network page of the FTDI Web site for the contact details of our distributor(s) and sales representative(s) in your country.

Appendix A - PCB EEPROM Configuration

Each USB-RS232-PCB is controlled by the FTDI FT232R IC. This FT232R device contains an EEPROM which contains the USB configuration descriptors for that device. When the PCB is plugged into a PC or a USB reset is performed, the PC will read these descriptors. The default values stored into the internal EEPROM are defined in Table 0.1 Default Internal EEPROM Configuration

Parameter	Value	Notes
USB Vendor ID (VID)	0403h	FTDI default VID (hex)
USB Product UD (PID)	6001h	FTDI default PID (hex)
Serial Number Enabled?	Yes	
Serial Number	See Note	A unique serial number is generated and programmed into the EEPROM during device final test.
Pull down I/O Pins in USB Suspend	Disabled	Enabling this option will make the device pull down on the UART interface lines when the power is shut off (PWREN# is high).
Manufacturer Name	FTDI	
Product Description	See note	USB-RS232-PCB
Max Bus Power Current	90mA	
Power Source	Bus Powered	
Device Type	FT232R	
USB Version	0200	Returns USB 2.0 device description to the host. Note: The device is be a USB 2.0 Full Speed device (12Mb/s) as opposed to a USB 2.0 High Speed device (480Mb/s).
Remote Wake Up	Disabled	
High Current I/Os	Enabled	Enables the high drive level on the UART and CBUS I/O pins.
Load VCP Driver	Enabled	Makes the device load the VCP driver interface for the device.
Invert TXD	Disabled	Signal on this pin becomes TXD# if enable.
Invert RXD	Disabled	Signal on this pin becomes RXD# if enable.
Invert RTS#	Disabled	Signal on this pin becomes RTS if enable.
Invert CTS#	Disabled	Signal on this pin becomes CTS if enable.

Table 0.1 Default Internal EEPROM Configuration

The internal EEPROM on the PCB can be re-programmed over USB using the utility program MPROG. MPROG can be downloaded from the www.ftdichip.com. Version 2.8a or later is required for the FT232R chip. Users who do not have their own USB Vendor ID but who would like to use a unique Product ID in their design can apply to FTDI for a free block of unique PIDs. Contact FTDI support for this service.

Appendix B - List of Figures and Tables

List of Figures

Figure 1.1 Using the USB-RS232-PCB	1
Figure 4.1 USB-RS232-PCB Pin Out (Top is TOP View, Bottom is BOTTOM View).....	7
Figure 4.2 USB-RS232-PCB, Mechanical Details.....	8
Figure 5.1 Circuit Schematic of USB-RS232-PCB.....	11

List of Tables

Table 1.1 USB-RS232-PCB Part Number	1
Table 4.1 USB-RS232-PCB Signal Descriptions	9
Table 4.2 UART Signal Level Selection.....	9
Table 4.3 USB-RS232-PCB.....	10
Table 4.4 USB-RS232-PCB I/O Pin Characteristics	10
Table 4.5 USB-RS232-WE ESD Tolerance.....	10
Table 0.1 Default Internal EEPROM Configuration	13

Appendix C - Revision History

Version Draft	First Draft	August 2008
Version 1.0	First Release	September 12th 2008
Version 1.1	Update to Taiwan address	October 1 st 2008
Version 1.2	Update to UK and CH address	February 11 th 2009
Version 1.3	Update to PCB drawings to show REV1 and REV2	April 13 th 2009
Version 1.4	Update figure 5.1 – Schematic Updated section 4 (changes made from Rev1 to rev2) Updated contact information	May 28th 2010
Version 1.41	Added the RoHs compliant statement in section 1 Added section 1.2 USB compliant Logo	January 26 th 2011



Компания «ЭлектроПласт» предлагает заключение долгосрочных отношений при поставках импортных электронных компонентов на взаимовыгодных условиях!

Наши преимущества:

- Оперативные поставки широкого спектра электронных компонентов отечественного и импортного производства напрямую от производителей и с крупнейших мировых складов;
- Поставка более 17-ти миллионов наименований электронных компонентов;
- Поставка сложных, дефицитных, либо снятых с производства позиций;
- Оперативные сроки поставки под заказ (от 5 рабочих дней);
- Экспресс доставка в любую точку России;
- Техническая поддержка проекта, помощь в подборе аналогов, поставка прототипов;
- Система менеджмента качества сертифицирована по Международному стандарту ISO 9001;
- Лицензия ФСБ на осуществление работ с использованием сведений, составляющих государственную тайну;
- Поставка специализированных компонентов (Xilinx, Altera, Analog Devices, Intersil, Interpoint, Microsemi, Aeroflex, Peregrine, Syfer, Eurofarad, Texas Instrument, Miteq, Cobham, E2V, MA-COM, Hittite, Mini-Circuits, General Dynamics и др.);

Помимо этого, одним из направлений компании «ЭлектроПласт» является направление «Источники питания». Мы предлагаем Вам помощь Конструкторского отдела:

- Подбор оптимального решения, техническое обоснование при выборе компонента;
- Подбор аналогов;
- Консультации по применению компонента;
- Поставка образцов и прототипов;
- Техническая поддержка проекта;
- Защита от снятия компонента с производства.



Как с нами связаться

Телефон: 8 (812) 309 58 32 (многоканальный)

Факс: 8 (812) 320-02-42

Электронная почта: org@eplast1.ru

Адрес: 198099, г. Санкт-Петербург, ул. Калинина, дом 2, корпус 4, литера А.