



Serial RapidIO Physical Layer Interface

User's Guide

Introduction

RapidIO is a high performance, low pin count, packet switched, full duplex, system level interconnect architecture. The architecture addresses the need for faster bus speeds in an intra-system interconnect for microprocessors, digital signal processors, communications and network processors. It also offers error management and provides a well-defined architecture for recovering from and reporting transmission errors.

RapidIO systems contain endpoint and switch processing elements. The RapidIO interconnect architecture is partitioned into a layered hierarchy of specifications which includes Logical, Common Transport and Physical layers. The Logical layer defines the operations and transactions by which endpoint processing elements communicate with each other. The Common Transport layer defines how the transactions are routed from one endpoint processing elements to another through switch processing elements. The Physical layer defines the interface between two devices and the packet transport mechanism, flow control and electrical characteristics. Currently there are two defined Physical layer specification, an 8-bit or 16-bit wide parallel specification and a 1-lane (1x) or 4-lane (4x) serial specification.

This user's guide explains the information about Lattice's Serial RapidIO Physical Layer specification and interface.

The Serial RapidIO Physical Layer core comes with the following documentation and files:

- Data sheet
- User's guide
- Lattice evaluation gate level netlist
- Simulation model for evaluation
- Core instantiation template
- Testbench and testbench coding template

The following experience is recommended for the user to implement a design using this IP:

- Familiarity with the Lattice ORCA® ORT82G5/ORT42G5 FPSC architecture
- Familiarity with simulation, synthesis and Lattice ispLEVER® design tools
- Knowledge of the *RapidIO Interconnect Specification Part VI: Physical Layer 1x/4x LP-Serial Specification Rev. 1.2, 06/2002*

Features

- Supports high speed 1x mode (up to 2.5 Gbps)
- 8B/10B encoding and decoding
- Clock and Data Recovery (CDR)
- Lane synchronization
- CRC generation and checking
- Error detection
- Packet/control symbol assembly and de-assembly
- Simple user interface for easy integration into user logic
- Targets ORT82G5/ORT42G5 FPSC

General Description

The Serial RapidIO core supports the physical layer specification as defined in the *RapidIO Specification Rev 1.2*. The Serial RapidIO Physical Layer defines a protocol for packet delivery between Serial RapidIO devices and other devices, including packet transmission, flow control, error management and link maintenance protocols. The core supports one-lane high speed (1x mode) running at 1.0, 2.0 Gbps or a maximum of 2.5 Gbps.

This Serial RapidIO core is optimized to support ORT82G5/ORT42G5 FPSCs.

For more information on Lattice products, refer to the Lattice web site at www.latticesemi.com.

Block Diagram

Figure 1. Physical Layer Block Diagram

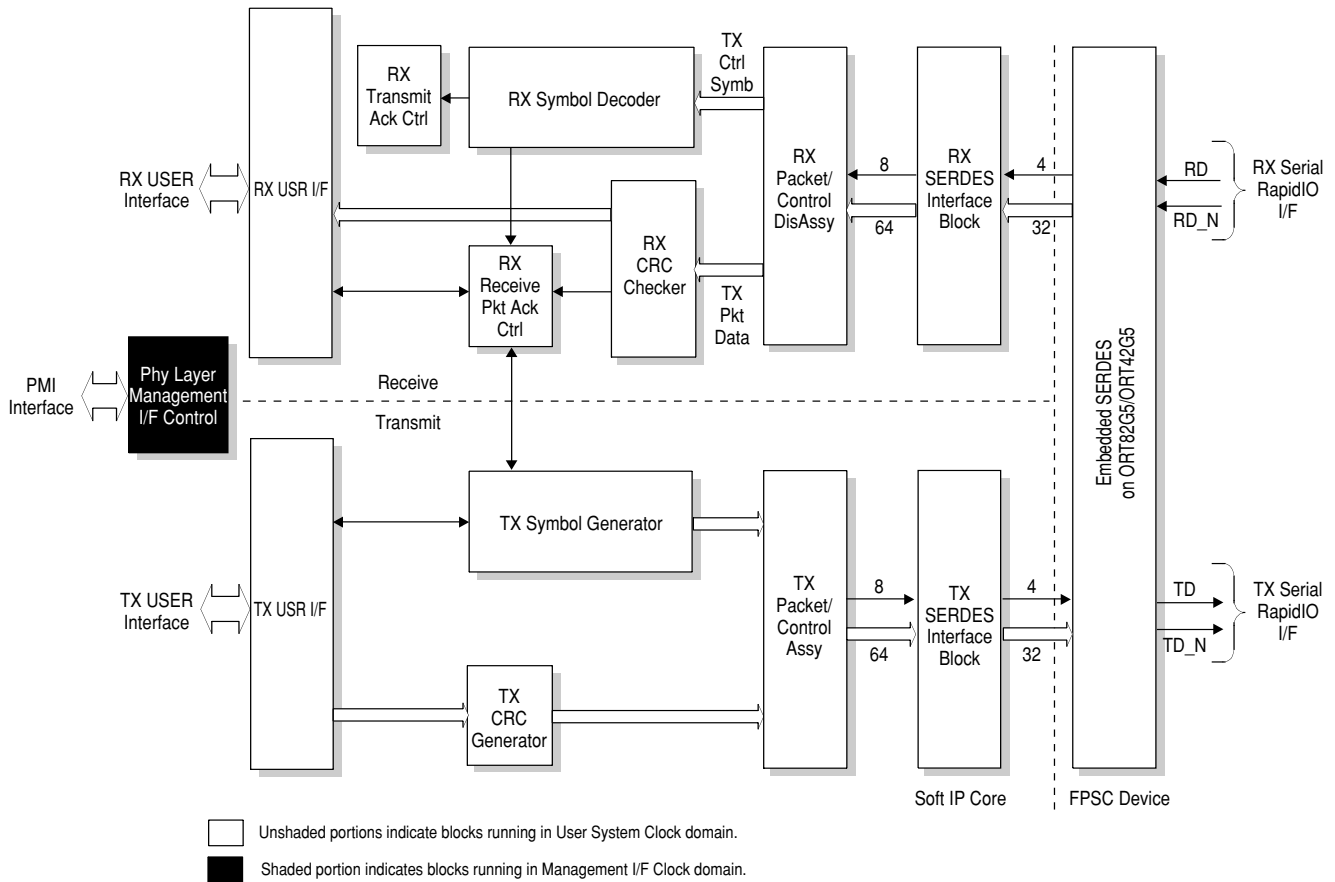

Functional Description

Figure 1 shows the block diagram of the Serial RapidIO Physical Layer core. Transmit data presented at the TX User Interface is first passed through a CRC (Cyclic Redundancy Code) generation block and then to the TX Packet/Control assembly block that assembles the packets and control symbols. The control symbols for this block are received from the TX Symbol Generator. The assembled data which contains both packet and control symbols are sent to the TX SERDES Interface block.

The incoming data from the RX Serial RapidIO Interface are processed by the RX SERDES Interface block. The data is then passed to the RX Packet and Control Disassembly block. This block separates the data packets from the control symbols. The data packets are sent to the RX CRC Checker and the control symbols are sent to RX Symbol Decoder.

The decoded control symbols are passed to the RX Transmit Ack Ctrl and RX Receive Packet Ack Ctrl blocks, which takes the appropriate actions. Finally the data from the RX CRC Checker is sent out to the user logic through the RX User Interface.

Embedded SERDES on Lattice ORT82G5/ORT42G5 FPSC device: Several RapidIO processes are performed in the device's embedded SERDES such as clock and data recovery, 8b/10b encoding and decoding, and serial-to-parallel conversion or vice versa.

PHY Layer Management Interface (PMI) Block

This block contains the Command and Status Registers (CSR) that allow the user to configure and read the capabilities, configuration and status of the input and output ports. For more detailed registers information refer to the Registers Description section of this document.

Transmit Physical Layer Block

TX User Interface

The TX User Interface generates all the signals necessary to interface to user logic or the Logical and Transport layers of the RapidIO stack. The main function of this block is to indicate that the TX PHY is ready to receive data from the user. It also controls the discard signal `tx_rios_discard`, which is used to discard a packet being sent to the core.

This block also generates the `tx_next_ackid` signal [ACK ID = 0 to 31], which indicates to the user the data associated to this ACK ID has to be sent. Since the user buffer can store up to 32 packets, this block generates a `tx_release_ackid` signal [ACK ID = 0 to 31] indicating that the packet designated by `tx_release_ackid` was sent and received successfully. The block interacts with the ACK Queue Management block to decide the next ACK ID value.

A detailed description of the operation of each signal in this interface is explained in the User Interface section of this document.

TX CRC Generator

This block generates the 16-bit CRC using the polynomial $X^{16} + X^{12} + X^5 + 1$. The CRC is generated over all of a packet header and the entire data payload, except the first six bits of the added physical layer fields (which are treated as logical 0s) as shown below. The initial value of the CRC is 0xFFFF, or all logic 1s. For the CRC calculation, the first six bits (ACK ID field and first reserved field) are assumed to be logic zero. This structure allows the ACK ID to be changed on a link-by-link basis as the packet is transported, without requiring the CRC to be recomputed for each link.

Figure 2. TX CRC Generator

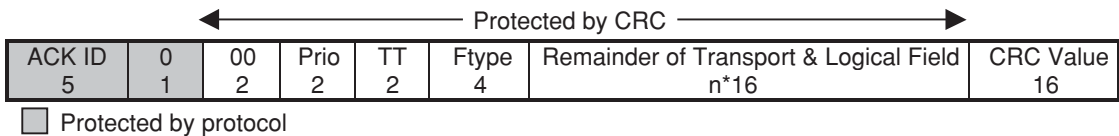

- Notes:
- n : number of data fields
 - The TX CRC generator is similar in functionality to the RX CRC Checker

For a packet that has less than or equal to 80 bytes of header (including all logical, transport, and 8/16 LP-LVDS fields) and logical data payload, a single CRC value is appended at the end of the packet.

For packets longer than 80 bytes (including physical layer header and logical data payload) a CRC value is inserted after the first 80 bytes, aligning it to the first half of the 32-bit alignment boundary, and a second CRC value is appended at the end of the packet. The second CRC value is a continuation of the first and included in the running calculation, meaning that the running CRC value is not re-initialized after it is inserted after the first 80 bytes of the packet.

This allows the RapidIO RX side to regard the embedded CRC value as two bytes of packet payload for CRC checking purposes. If the final appended CRC value does not cause the total packet to align to the 32-bit boundary, a 2-byte pad of all logic 0s is post appended to the packet. The pad of logic 0s allows the CRC check to always be aligned at the 32-bit boundary.

TX Symbol Generator

This block generates the appropriate control symbols based on the control symbol generation request and writes them into the Symbol Queue FIFO.

Control Symbols: This block stores the control symbols that are to be sent out in a synchronous FIFO. Since the data width is 64 bits, and each control symbol is 32 bits wide (24 bits data + 8 bits /SC/ special character), it can send up to two control symbols on every clock. Hence the FIFO stores up to 2 control symbols in one location. When only one control symbol is to be sent out the other control symbol contains stype0 = Status and stype1 = NOP.

Figure 3 shows the Serial RapidIO control symbol format, for more detailed information on control symbols please refer to Serial RapidIO specifications.

Figure 3. Control Symbol Format

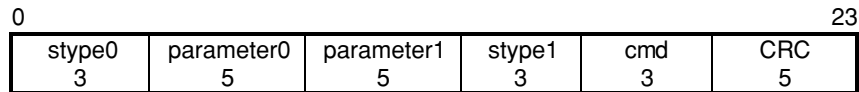

Outlined below is a list and description of the different symbols that are used in Serial RapidIO IP core.

Table 1. RapidIO Core Symbols

Symbol	Description
Stype 0 Control Symbols	Packet-Accepted Control Symbol (b000) indicates that the receiving device has taken responsibility for sending the packet to its final destination and that resources allocated by the sending device can be released. This control symbol shall be generated only after the entire packet has been received and found to be free of detectable errors.
	Packet-Retry Control Symbol (b001) indicates that the receiving device was not able to accept the packet due to some temporary resource conflict such as insufficient buffering and the sender should retransmit the packet.
	Packet-Not-Accepted Control Symbol (b010) indicates to the sender the packet was not accepted by the receiving port. The cause field indicates the reason for not accepting the packet.
	Status Control Symbol (b100) is the default stype0 encoding and is used when the control symbol does not convey another stype0 function. This control symbol indicates the number of maximum length packet buffers available at the sending port.
	Link-Response Control Symbol (b110) is used to respond to a link-request control symbol.
Stype1 Control Symbols	Start-of-Packet Control Symbol (b000) indicates the start of a packet.
	Stomp (b001) control symbol is used to cancel a partially transmitted packet.
	End-of-Packet Control Symbol (b010) indicates the end of the packet.
	Restart-from-Retry Control Symbol (b011) is used to respond to a packet-retry control symbol, this control symbol enables the receiver to start accepting packets after a packet-retry situation.
	Link Request Control Symbol (b100) <ul style="list-style-type: none"> • Reset-Device Command causes the receiving device to go through its reset or power-up sequence. This command is send on a user request. • Input-Status Command requests the receiving device to return its expected ACK ID value, this is sent out when the sender has encountered error conditions.
	Multicast-Event Control Symbol (b101) is used to multicast a user defined system event.

TX Packet/Control Assembly

The TX Packet/Control Assembly block gets packet data from the user logic and then appends physical layer header information within the relevant physical fields before sending the data to the TX SERDES Interface Block. It also adds control symbols received from the TX Symbol Generator block in-between packets. This block also generates and adds the 5-bit control symbol CRC shown in Figure 3 using the polynomial $X^5 + X^4 + X^2 + 1$. Figures 4 and 5 show the request and response packet formats.

Figure 4. Request Packets

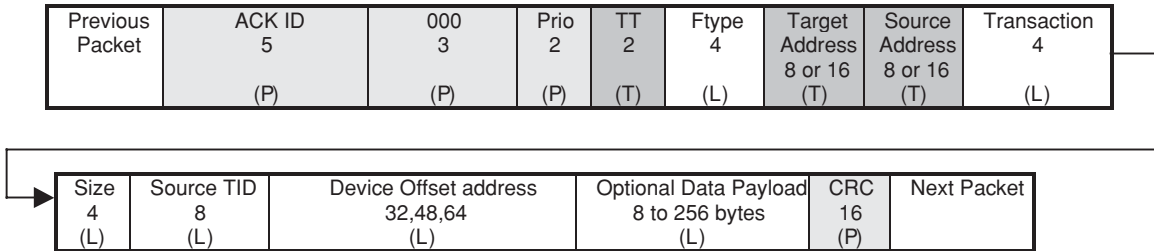
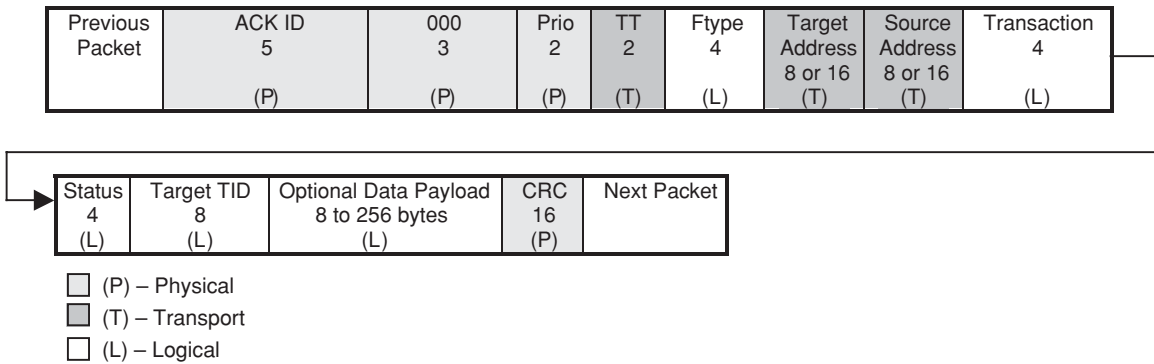

Figure 5. Response Packets



Note: These two kinds of packets are handled similarly. There is no difference between these two types of packets as far as physical layer is concerned.

TX SERDES Interface Block

The TX SERDES Interface Block connects this soft IP core to the embedded TX SERDES section of a Lattice ORT82G5/ORT42G5 FPSC device. This Interface Block generates the code-group sequences for transmission when neither data nor control symbols are being transmitted. Figure 6 shows the Receive and Transmit side of SERDES Interface block.

Figure 6. Detail of TX and RX SERDES Interface Blocks

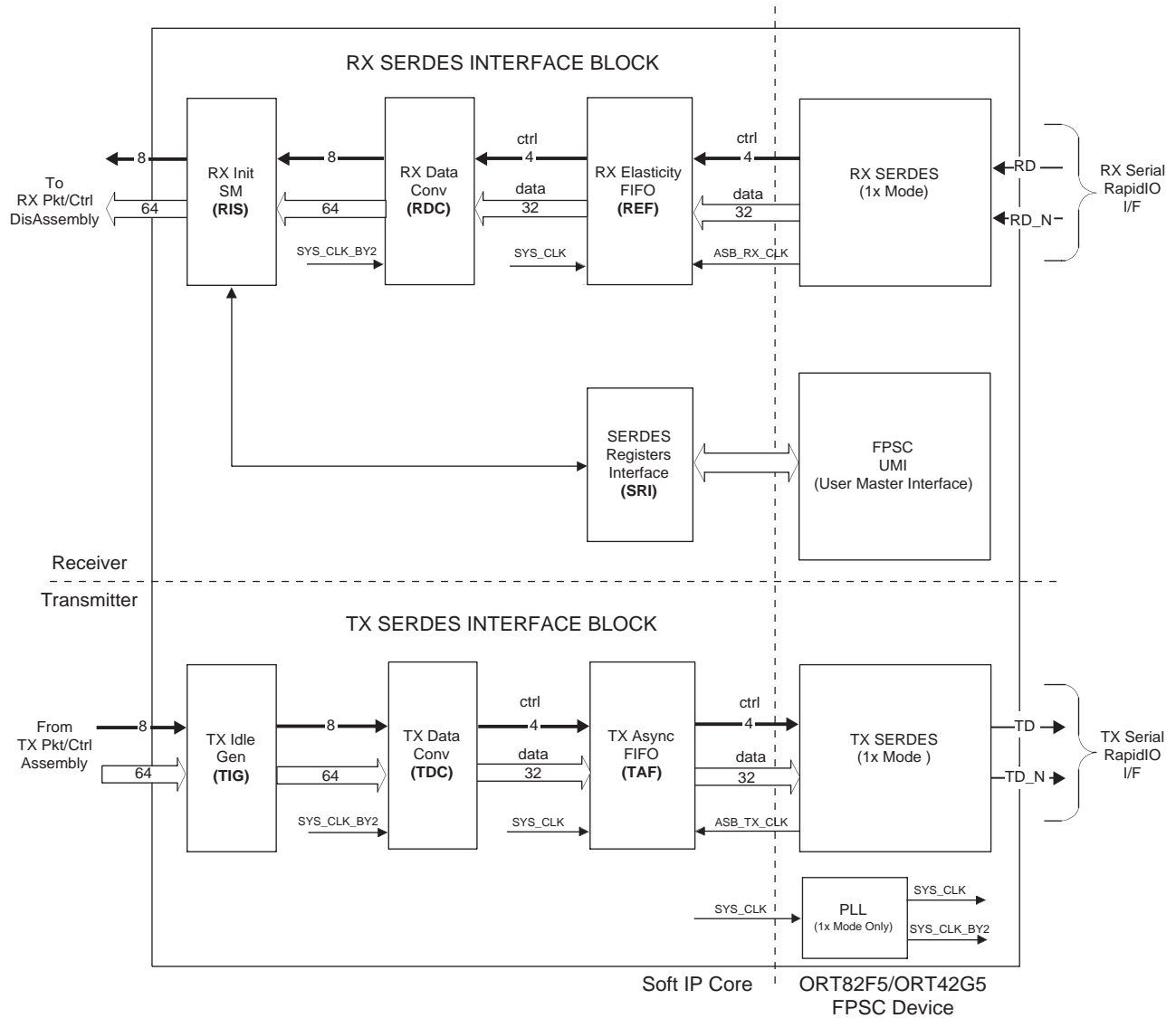

TX Idle Generator (TIG): This block is responsible for the following functions:

- Random Idle Sequence generation.
- Clock Compensation Sequence that will generate the idle sequence /K/ /R/ /R/ /R/ at least once for every 5000 code-groups that are transmitted, even when there are packets or control symbols available to transmit.

TX Data Converter (TDC): This block receives 64-bit data at 39 MHz from TX Idle Generator and converts it to 32-bit data at 78 MHz. This is implemented to interface the embedded SERDES since it can only accept 32-bit data at 78 MHz.

TX Asynchronous FIFO: This block is required to translate data from the TX user clock domain to the embedded SERDES clock domain. This FIFO will also allow the TX User Interface to stop sending data when the FIFO is almost full and to send the idle sequence when the FIFO is empty.

TX Embedded SERDES: This block is an embedded part of FPSC device. The 32-bit output data from TX Asynchronous FIFO is multiplexed to 8-bit data and 8B/10B encoded. The 10-bit encoded data is then serialized and

sent out to differential output pins. Figure 7 shows the internal data flow of TX SERDES block. For more information on this block, refer to the ORT82G5/ORT42G5 data sheet.

Figure 7. TX Embedded SERDES Data Flow

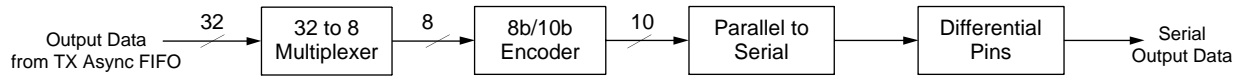

Receive Physical Layer Block

RX SERDES Interface Block

The RX SERDES Interface Block connects this soft IP core to the embedded RX SERDES section of a Lattice ORT82G5/ORT42G5 FPSC device. This Interface Block contains a retimer, data converter, and initialization state machine. Further details can be found in the User's Guide for this IP core.

RX Embedded SERDES: This block recovers the clock from the serial stream and decodes the 8B/10B data. This block also performs the Link Synchronization as specified in the Serial RapidIO specification. Figure 8 shows the internal data flow of RX SERDES block. For more information on this block, refer to the ORT82G5/ORT42G5 data sheet as well as Serial RapidIO specifications.

Figure 8. RX Embedded SERDES Data Flow

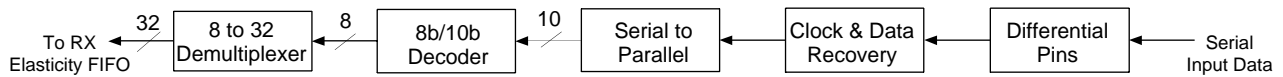

RX Elasticity FIFO: This block receives data from the RX Embedded SERDES. It acts as a retimer and corrects variations in the input clock with respect to the local RX clock. This is done by adding or removing code group /R/.

RX Data Converter: Since the embedded FPSC interface generates 32-bit data at 78 MHz, this block converts the received 32-bit data at 78 MHz to 64-bit data at 39 MHz.

RX Initialization State Machine: This block performs the 1x mode initialization as described in the Serial RapidIO specifications. Refer to the specification for a detailed description of this state machine. The lane initialization information is available as embedded registers inside the FPSC, and its status is reported using the UMI interface.

RX Packet/Control Disassembly

The RX Packet and Control Disassembly block separates the data packets and control symbols from the received data. This block also has the Control Symbol CRC Checker which checks the 5-bit CRC present in the control symbols received. If any errors are found on the control symbols, this information is passed to the RX Transmit Ack Ctrl block.

The separated data is sent to the RX CRC Checker block while the RX control symbols are sent to the RX Symbol Decoder block. This block also filters the idle sequences received.

The received packet data from the RX Packet and Control Disassembly block contains gaps in packet stream due to removal of packet physical headers and embedded control symbols. Before sending this data to the RX User Interface, this block aligns the start of packet so that the packet begins at the 64-bit boundary of the data bus.

RX Symbol Decoder

This block stores the ACK control symbols that are to be received into a synchronous FIFO. Since the data width is 64 bits, and each control symbol 32 bits wide (24 bits data + 8 bits/SC/special character), it can receive up to two control symbols on every clock. Hence the FIFO stores up to two control symbols received in one location. Subsequently, this block decodes the control symbol data. The decoded signals contain information on the type of control symbol that was decoded. For more detailed information on control symbols refer to the Serial RapidIO Specification.

RX Transmit ACK Control

The RX Transmit ACK control block keeps track of the acknowledgement control symbols for packets transmitted. This is implemented by maintaining an ACK received queue. Once a packet is accepted, an ACK ID number [ACK ID = 0 to 31] is sent to the user to release the packet buffer. In the case in which a packet needs to be resent a packet-retry ACK ID [ACK ID = 0 to 31] will be sent to the transmit block to send the packet once again. Similarly, for packets not accepted an ACK ID [ACK ID = 0 to 31] will be sent to the transmit block to resend the packet.

If a packet is still in transmission, a packet-retry or packet-not-accepted acknowledgment may cause the sender to cancel transmission on the packet. The sending device can use the stomp, restart-from-retry (in response to a packet-retry control symbol), or link-request (in response to a packet-not-accepted control symbol) control symbol to cancel the packet.

This block generates appropriate responses to the following control symbol errors. These errors are listed below:

- Error on control symbol
 - Packet-not-accepted control symbol
 - Packet-retry/package-ack control symbol with unexpected ACK ID
 - Corrupt control symbol
- Time out waiting for control symbol

Retry Recovery: The retry recovery state machine is part of the RX Transmit ACK Control (RTA) block. Its purpose is to attempt to recover data for a retry condition. It is triggered when a device receives a packet-retry control symbol to stop sending new packets. After sending a packet-retry control symbol, the state machine will then send a restart-from-retry control symbol to resend data in which the packet-retry control symbol was sent for.

Figure 9 shows an example of Retry Recovery flow control operation. In this example, after the transmitter transmits several packets, the receiver sends a packet-retry control symbol (RetryAck3) on packet #3 to transmitter. It asks the transmitter to resend packet #3 again. The receiver discards all packets received after packet #3. Once the transmitter detects the packet-retry control symbol, it stops sending new packets until it sends an input status of restart-from-retry to the receiver to prepare to receive incoming packets.

Figure 9. Retry Recovery Control Data Flow

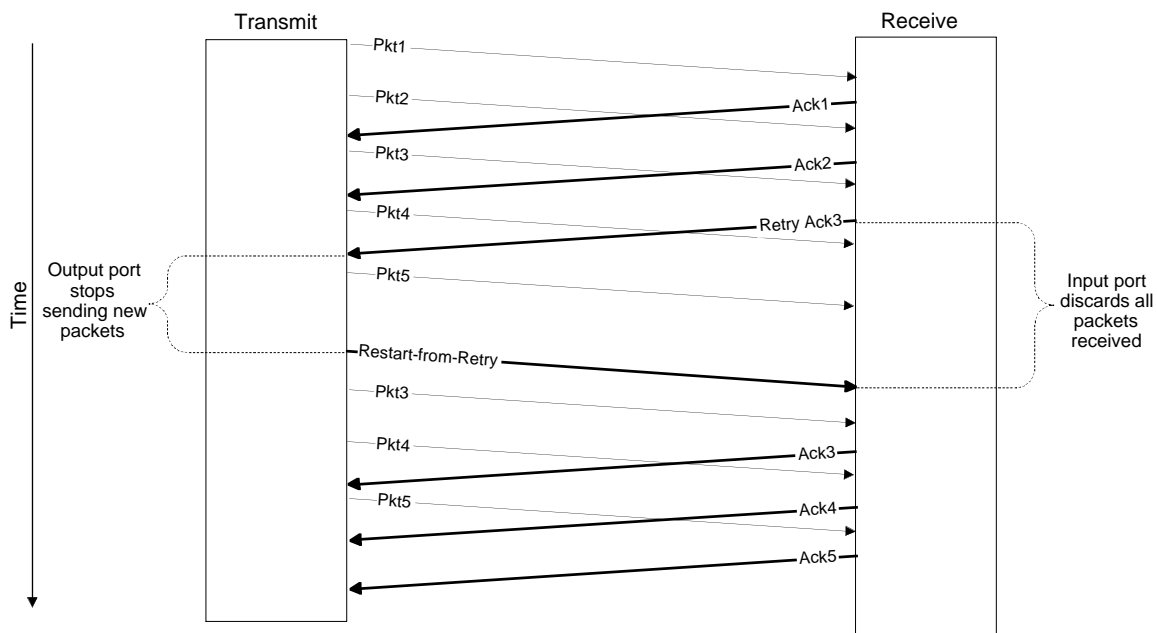

It is possible that by the time the transmitter receives the packet-retry control symbol (RetryAck3), it is still transmitting packet to the receiver due to the transmitter latency to process the packet-retry control symbol. This condition is fine since the receiver discards all incoming packets received after it sends packet-retry control symbols. For more information on the retry recovery state machine, refer to the Serial RapidIO specifications

Error Recovery: The error recovery state machine is also part of RX Transmit ACK Control (RTA) block which has function to attempt to recover data for error conditions. When this state machine detects an output error such as an unexpected ACK ID the state machine immediately transitions into an output error-stopped state and immediately stops sending new packets and issues a restart-from-error control symbol to the sender. The restart-from-error control symbol receives a response from the receiver including the ACK ID. This ACK ID indicates where the sender should begin re-transmission. For more information on the error recovery state machine, refer to the Serial RapidIO Specification. Figure 10 shows an example of Error Recovery flow control operation.

Figure 10. Error Recovery Flow Diagram

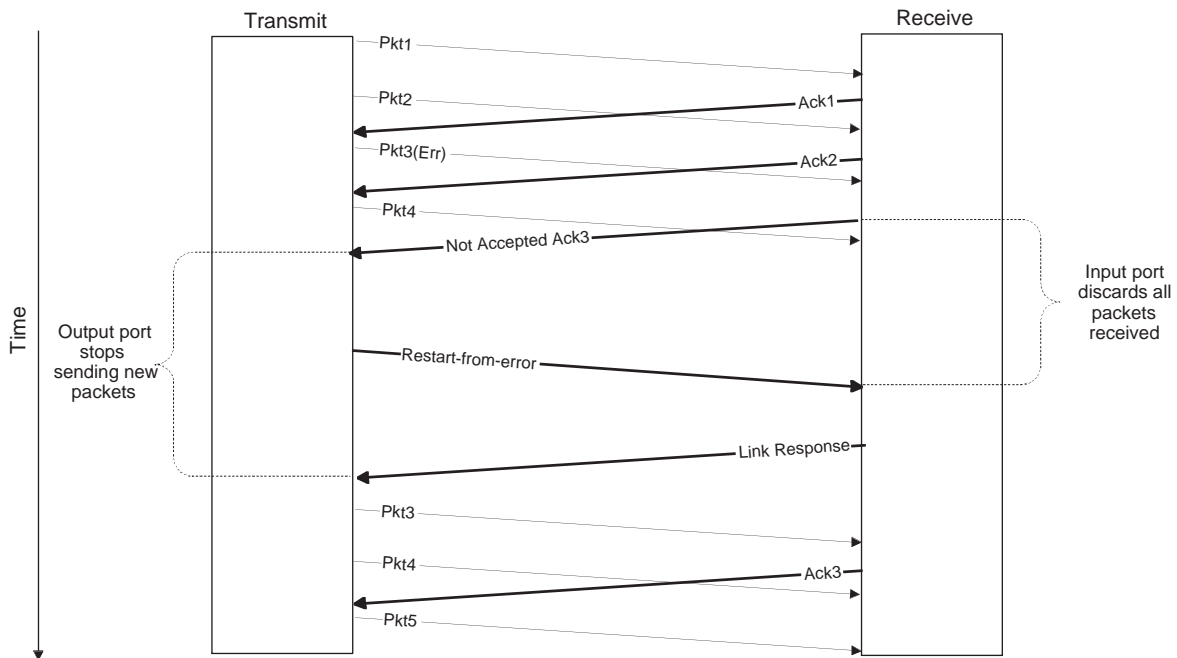

RX Receive Packet ACK Control

The RX Receive Packet ACK Control block generates the ACK control symbols for the packets received.

The different packet errors are as follows:

- Unexpected ACK ID on packets
- Corrupt packet indicated by CRC
- Packet that overruns defined packet boundary

When this block detects an error on a packet (CRC error/unexpected ACK ID value/over running the maximum data payload) it immediately transitions into an input error-stopped state and silently discards all new packets until it receives a restart-from-error control symbol from the sender. The state machine also sends a control symbol with the received ACK ID value back to the sender, which indicates that the packet is not accepted. The sender then initiates recovery by resending of the packet.

This block uses the error recovery and retry recovery state machines, similar to the ones defined in the RX Receive Transmit ACK block.

RX CRC Checker

The RX CRC Checker generates a separate CRC for each data packet and compares it to the appended CRC transmitted with each packet, to determine any errors.

The CRC is generated for the packet header and the entire data payload, with the exception of the first 6 bits of the added physical layer fields (which are treated as logical 0's). The initial value of the CRC is 0xFFFF. For the CRC calculation, the first 6 bits (ACK ID field and first bit of reserved field) are assumed to be logic zero. This structure allows the ACK ID to be changed on a link-by-link basis as the packet is transported, without requiring the CRC to be recomputed for each link.

Figure 11 shows the format of packet with CRC.

Figure 11. CRC Checking

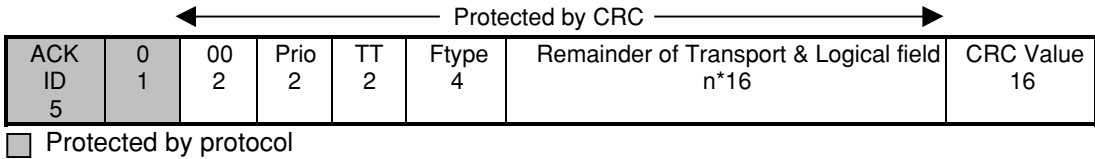

The leading 16 bits of the packet are referred to as the first symbol of the packet. The first symbol of a packet shall always land on the most significant half of the 32-bit boundary.

For a packet that has less than or equal to 80 bytes of header (including all logical, transport, and 8/16 LP-LVDS fields) and logical data payload, a single CRC value is appended to the packet.

For packets with greater than 80 bytes (including physical layer header and logical data payload) a CRC value is inserted after the first 80 bytes, aligning it to the first half of the 32-bit alignment boundary, and a second CRC value is appended at the end of the packet. The second CRC value is a continuation of the first and included in the running calculation, meaning that the running CRC value is not re-initialized after it is inserted after the first 80 bytes of the packet.

This allows the devices to regard the embedded CRC value as two bytes of packet payload for CRC checking purposes. If the final appended CRC value does not cause the total packet to align to the 32-bit boundary, a 2-byte pad of all logic 0's is post appended to the packet. The pad of logic 0's allows the CRC check to always be done at the 32-bit boundary.

RX User Interface

The RX User Interface generates all the control signals necessary to interface to the RX user logic or the Logical and Transport layers of the RapidIO stack. This block generates the signals indicating that the RX PHY is ready to send data. This block also controls the discard signal, which is used to discard a packet being sent to the user logic if packet errors are detected.

The block is used by the user logic to receive data and core status from the Serial RapidIO core, and to interface to a simple FIFO interface. The signals generated/used by this block are described in the User Interface section and the Signal Description section of this document.

User Interface

This section explains in detail the user interface signals that are present in this Serial RapidIO PHY IP. The following are the different user interfaces:

- TX User Interface
- RX User Interface
- PMI Interface

TX User Interface

The TX User Interface consists of two types of interface: TX User Control Interface and TX Generic FIFO Bridge Interface. Both run synchronously with the system clock `sys_clk` signal.

The TX User Control Interface generates all the control signals required for the TX user such as `tx_rios_ready`, `tx_next_ackid`, `tx_release_ackid`, `tx_rios_discard` and `tx_release_val`. The TX Generic FIFO Bridge Interface is a standard FIFO interface used to manage the data flow coming from the user side (signals beginning with "sine_tx_").

After the device is powered up and `reset_n` signal is asserted, the Serial RapidIO core goes through an internal initialization cycle. During this time, the core initializes the ORT82G5/ORT42G5 SERDES registers, checks whether the SERDES Receive channel is synchronized and performs 1x initialization. Once this is successful, the `tx_rios_ready` signal is asserted indicating that the core is ready for transmitting Serial RapidIO packets.

Note: During the transmit process, the status of `tx_rios_ready` must be monitored at all times. When `tx_rios_ready` is de-asserted, all user interface signals should be regarded as invalid input or invalid output.

Once the `tx_rios_ready` is asserted, the `tx_next_ackid[4:0]` indicates the ACK ID of the buffer to be transmitted. These buffers are numbered from 0 to 31 and are maintained by the user. Each of these buffers contains a packet that has to be transmitted through the Serial RapidIO core. The implementation of these buffers is left to the user and is not specified by this document.

If a packet has been successfully transmitted by the core, i.e. after the core receives an acknowledgement from the far end receiver, the signal `tx_release_val` goes active indicating that the user buffer associated with the `tx_release_ackid[4:0]` value can be released. This means that the user can now store a different packet into the buffer that has been released. The buffer should not be updated with a new packet until a release signal `tx_release_ackid` has been received on that buffer.

Once a complete packet is available at the user end for transmission, the user has to indicate this to the core by asserting the `sine_tx_data_avail` signal. On seeing the `sine_tx_data_avail` signal active, the core activates the read signal `sine_tx_read`.

Once the `sine_tx_read` is activated, the user should provide the requested buffer data on these signals. The other signals associated with this data transfer are `tx_prio[1:0]`, `sine_tx_sof`, `sine_tx_data[63:0]`, `sine_tx_data_en[3:0]` and `sine_tx_eof`.

The `sine_tx_sof` signal should be asserted at the start of the packet and `sine_tx_eof` should be asserted at the end of the packet. The `sine_tx_sof` signal should only be asserted for one clock cycle. When `sine_tx_read` is asserted, it initiates the packet transfer while the core is waiting for this signal asserted. As soon as it detects the `sine_tx_sof` asserted, it immediately goes to the next step of the internal processing algorithm.

The `tx_prio[1:0]` indicates the priority field of the Serial RapidIO packet. The `sine_tx_data_en[3:0]` indicates valid half word of the `sine_tx_data` of the current packet transfers.

The `sine_tx_alm_empty` signal should be asserted whenever the buffer contains only one 64-bit data left. This signal is used to deactivate the `sine_tx_read` signal to prevent the core from issuing illegal reads.

During a data transfer from the user side to the core, i.e. when `sine_tx_read` is active, the user can terminate the transfer by activating the `tx_usr_discard`. Similarly the core can terminate the packet by activating the `tx_rios_discard`. The reasons on which the user can terminate the packet transfer are user implementation dependent and are not specified by this document.

RX User Interface

The RX User Interface consists of RX User Control Interface and RX Generic FIFO Bridge Interface. Both run synchronously with the system clock `sys_clk` signal. The RX User Control Interface generates all the control signals required for the RX user such as `rx_rios_ready` and `rx_rios_discard`. The RX Generic FIFO Bridge

Interface is a standard FIFO interface used to manage the data flow going to the user logic side (signals beginning with "sine_rx_").

After the device is powered up and `reset_n` signal is activated, the Serial RapidIO core goes through an internal initialization cycle, during which the core initializes the ORT82G5/ORT42G5 SERDES registers, checks the synchronization of SERDES Receive Channel and performs 1x initialization. Once this is successful the `rx_rios_ready` signal goes active indicating that the other control signals on the RX interface are valid.

After the `rx_rios_ready` is active, whenever the core receives a good packet, the core generates a `sine_tx_write` signal indicating that the data transfer to the user is active. The other signals associated with this data transfer are: `sine_rx_sof`, `sine_rx_data[63:0]`, `sine_rx_hwen[3:0]` and `sine_rx_eof`.

The `sine_rx_sof` signal will always be asserted at the start of the packet to indicate the beginning of new packet. However, for the end of the packet case, the `sine_rx_eof` signal may or may not be asserted.

There are two conditions indicating that the transfer of one packet has ended:

1. The assertion of the `sine_rx_eof` signal at the end of the packet.
2. The assertion of the `sine_rx_sof` signal to indicate that a new packet is started and the previous packet has been ended.

The `sine_rx_hwen[3:0]` indicates the valid half word of the data bus `sine_rx_data` of the current packet transfer. When the packet is being transferred, invalid and valid data could be sent on the same packet. Thus, it is important for user to use both `sine_rx_hwen[3:0]` signals and `sine_rx_data` bus together to determine the validity of data in the current packet.

During a data transfer from the core to the user side, i.e. when `sine_rx_write` is active, the user can terminate the transfer by activating the `rx_usr_discard`. Similarly the core can terminate the packet by activating the `rx_rios_discard`. The reasons on which the user can terminate the packet transfer are user implementation dependent and are not specified by this document.

The user also provides the `rx_buf_status[4:0]` signal which indicates number of available packet buffers in user logic. Encoding value specifies the number of packet buffers the receiving device has currently available. The value "00000" specifies buffer is full, "11110" specifies 30 spaces available and "11111" specifies undefined number of spaces available. The core uses this buffer status signal whenever a control symbol is generated and sent out.

PMI Interface

The Physical Layer Management Interface (PMI) is used to read the registers present in the IP and the registers present in the ORT82G5/ORT42G5 embedded SERDES block.

This interface uses a separate clock signal called `pmi_usr_clk`. Thus, the interface can run independently and at a different frequency compared to Transmit or Receive blocks in the core.

After the device is powered up and has gone through a reset cycle using the `reset_n` signal, the `pmi_ready` signal will be inactive indicating to the user that the interface is ready to accept read/write cycles.

Once the `pmi_ready` is deasserted or inactive, user can perform a read operation by pulsing the `pmi_sel` signal along with the `pmi_addr` signal which contains the address of the register to be read, and the signal `pmi_wr` should be active low indicating a read command. After the above sequence the user logic should wait for the `pmi_ready` signal to go high indicating successful completion of the read cycle and the data read out from the register will be available on the `pmi_dataout[31:0]` data bus.

To perform a write cycle the user logic first has to check if the `pmi_ready` is low. After that, the write operation can be performed by pulsing the `pmi_sel` signal along with the `pmi_addr` which contains the address of the register to be written. The bus `pmi_datain[31:0]` should contain the data to be written into the register and the `pmi_wr`

signal should be active high indicating a write command. After the above sequence, the user logic should wait for the `pmi_ready` signal to go high indicating successful completion of the write cycle. The data on `pmi_datain[31:0]` bus should remain valid during the `pmi_ready` signal asserted.

Register Descriptions

This section describes the different registers available in this core. Table 2 shows the overall global memory map of the IP and different register sets implemented.

Table 2. Register Memory MAP

Address	Description
USR_RIOPHY_BASE +16'h0xxx	PHY CSR Registers. These implement the PHY Command and Status Registers as defined in the Serial RapidIO Specification.
USR_RIOPHY_BASE +16'h1xxx	User Registers. These implement the registers required by the core, and gives status information about the core.
USR_RIOPHY_BASE +16'h2xxx	SERDES Registers. For SERDES Registers please refer to the ORT42G5/ORT82G5 FPSC data sheet available at www.latticesemi.com .

Table 3 shows different PHY CSR registers implemented in this core.

Table 3. PHY CSR Registers

Offset Address	Name	Description
'h000	PHY_HEADER0	Port Maintenance Block Header 0
'h004	PHY_HEADER1	Port Maintenance Block Header 1
'h020	PHY_LINK_TO	Port Link Time-Out Control CSR
'h024	PHY_RESP_TO	Port Response Time-Out Control CSR
'h03C	PHY_GEN_CTL	Port General Control CSR
'h058	PHY_ERR_STAT	Port Error and Status CSR
'h05C	PHY_CONTROL	Port 0 Control CSR

Table 3a. PHY_HEADER0

Name	Bits	Reset Value	Access	Description
EF_PTR	15:0	'EF_PTR	R	Hard wired pointer to the next block in the data structure, if one exists
EF_ID	31:16	'h0001	R	Hard wired Extended Features ID

Table 3b. PHY_HEADER1

Name	Bits	Reset Value	Access	Description
—	31:0	—	—	Reserved

Table 3c. PHY_LINK_TO

Name	Bits	Reset Value	Access	Description
link_time_out	23:0	'hFFFF	RW	Time-out interval value
—	31:24	—	—	Reserved

Table 3d. PHY_RESP_TO

Name	Bits	Reset Value	Access	Description
resp_time_out	23:0	'hFFFF	RW	Time-out interval value
—	31:24	—	—	Reserved

Table 3e. PHY_GEN_CTL

Name	Bits	Reset Value	Access	Description
host	0	0	RW	A Host device is a device that is responsible for system exploration, initialization, and maintenance. Agent or slave devices are typically initialized by Host devices. 'b0 - agent or slave device 'b1 - host device
master_enable	1	0	RW	The Master Enable bit controls whether or not a device is allowed to issue request into the system. If the Master Enable is not set, the device may only respond to requests. 'b0 - processing element cannot issue request 'b1 - processing element can issue requests
discovered	2	0	RW	This device has been located by the processing element responsible for system configuration. 'b0 - The device has not been previously discovered 'b1 - The device has been discovered by another processing element
-	31:3	-	-	Reserved

Table 3f. PHY_ERR_STAT

Name	Bits	Reset Value	Access	Description
—	10:0	—	—	Reserved
output_retry_enc	11	0	RW	Output port has encountered a retry condition. This bit is set until written with a logic 1 to clear.
output_retried	12	0	R	Output port has received a packet-retry control symbol and cannot make progress. This bit is set when bit 13 is set and is cleared when a packet-accepted or a packet-not-accepted control symbol is received.
output_retry_stop	13	0	R	Output port has received a packet-retry control symbol and is in the output-retry-stopped state.
output_err_enc	14	0	RW	Output port has encountered (and possibly recovered from) a transmission error. This bit is set when bit 15 is set. Once set, it remains set until written with a logical 1 to clear.
output_err_stop	15	0	R	Output port is in the output error-stopped state.
-	20:16	—	—	Reserved
input_retry_stop	21	0	R	Input port is in the input retry-stopped state.
input_err_enc	22	0	RW	Input port has encountered (and possibly recovered from) a transmission error. This bit is set when bit 23 is set. Once set, it remains set until written with a logic 1 to clear.
input_err_stop	23	0	R	Input port is in the input error-stopped state.
—	26:24	—	—	Reserved
port_write_pend	27	0	RW	Port has encountered a condition, which required it to initiate a Maintenance Port-write transaction. This bit is only valid if the device is capable of issuing a maintenance port -write transaction. Once set, it remains set until written with a logic 1 to clear.

Table 3f. PHY_ERR_STAT (Continued)

Name	Bits	Reset Value	Access	Description
—	28	—	—	Reserved
port_error	29	0	RW	Input or output port has encountered an error from which hardware was unable to recover. Once set, it remains set until written with a logic 1 to clear.
port_ok	30	0	R	Input and output ports are initialized and can communicate with the adjacent device. This bit and bit 31 are mutually exclusive.
port_uninit	31	1	R	Input and output ports are not initialized and is in training mode. This bit and bit 30 are mutually exclusive.

Table 3g. PHY_CONTROL

Name	Bits	Reset Value	Access	Description
port_width	1:0	00	R	Operating width of the port: 00 Single Lane 10 Four Port 01-11 Reserved
initialized_port_width	4:2	000	R	Init Port width: 000 Single port Lane 0 100 Single Port Lane 2 010 Four Port Lane 110-111 Reserved
port_width_override	7:5	000	RW	Soft port Config Override: 000 No override 100 Reserved 010 Force single lane Lane 0 110 Force single lane Lane 2 001-111 Reserved
port_disable	8	0	R/W	Port Disable: 0 Disable Receiver/driver 1 Disable Receiver/driver
output_port_en	9	0	RW	Output port transmit enable: 0 - port is stopped and only enabled to route or respond I/O logical MAINTENANCE packets, depending upon the functionality of the processing element. Control symbols are not affected and are received and handled normally. 1 - port is enabled to respond to any packet
input_port_en	10	0	RW	Input port receive enable: 0 - port is stopped and only enabled to route or respond I/O logical MAINTENANCE packets, depending upon the functionality of the processing element. Other packets generate packet-not-accepted control symbols to force an error condition to be signaled by the sending device. Control symbols are not affected and are received and handled normally. 1 - port is enabled to respond to any packet
err_chk_dis	11	0	RW	This bit disables all RapidIO transmission error checking: 0 - Error checking and recovery is enabled 1 - Error checking and recovery is disabled Device behavior when error checking and recovery is disabled and an error condition occurs is undefined

Table 3g. PHY_CONTROL (Continued)

Name	Bits	Reset Value	Access	Description
multicast_partp	9	0	R	Send incoming multicast-event control symbols to this port (multi port devices only)
—	30:13	—	—	Reserved
port_type	31	1	R	This indicates the port type, parallel or serial: 0 - Parallel port 1 - Serial port

The following table shows the different USER registers implemented in this core.

Table 4. User Registers

Offset Address	Name	Description
'h000	USR_STATUS	Status Register
'h004	USR_SYMBOL	Symbol register
'h008	USR_RETRANS_CNT	Maximum number of times a packet can be retransmitted when packet is not accepted.

Table 4a. USR_STATUS

Name	Bits	Reset Value	Access	Description
force_reinit	0	0	RW	For initialization, <code>force_reinit</code> to be written with logic 1. When initialization is complete, <code>force_reinit</code> will return logic 0.
err_ackid	1	0	RW	Indicates Link Response Fatal Error. The link response contains the ACKID that is not outstanding
cs_sent	2	1	R	Requested Control Symbol is sent
init_done	3	0	W	Management configured the registers, so that ports are ready
reset_cs	4	0	RW	Reset control symbol received
naccptd_cause	9:5	0	R	Displays reasons why packet not accepted: 00000: Reserved 00001: Received unexpected ACKID on packet 00010: Received a control symbol with bad CRC 00011: Non-maintenance packet reception is stopped 00100: Received packet with bad CRC 00101: Received invalid character, or valid but illegal character 11110: Reserved 11111: General error
mc_event	10	0	R/W	MC event received, set by core cleared by user.
—	31:11	—	—	Reserved

Table 4b. USR_SYMBOL

Name	Bits	Reset Value	Access	Description
cs	5:0	'h0000	RW	Control symbol that need to be sent (given by the user)
—	31:6	-	—	Reserved

Table 4c. USR_RETRANS_CNT

Name	Bits	Reset Value	Access	Description
retrans_cnt	2:0	'h7	RW	Maximum number of times a packet can be retransmitted when packet is not accepted
—	31:3	—	—	Reserved

Timing Diagrams

Transmit User Interface

Figure 12. TX User Data Transfer of a Packet

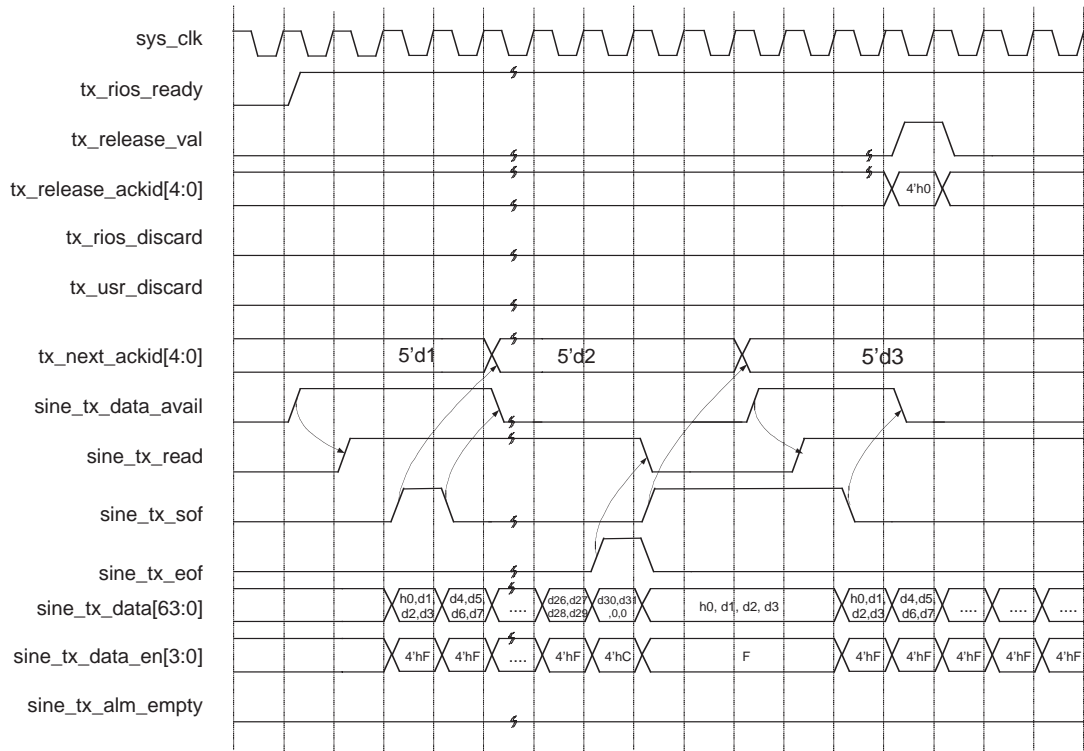

Figure 13. TX Discarding a Packet by tx_usr_discard

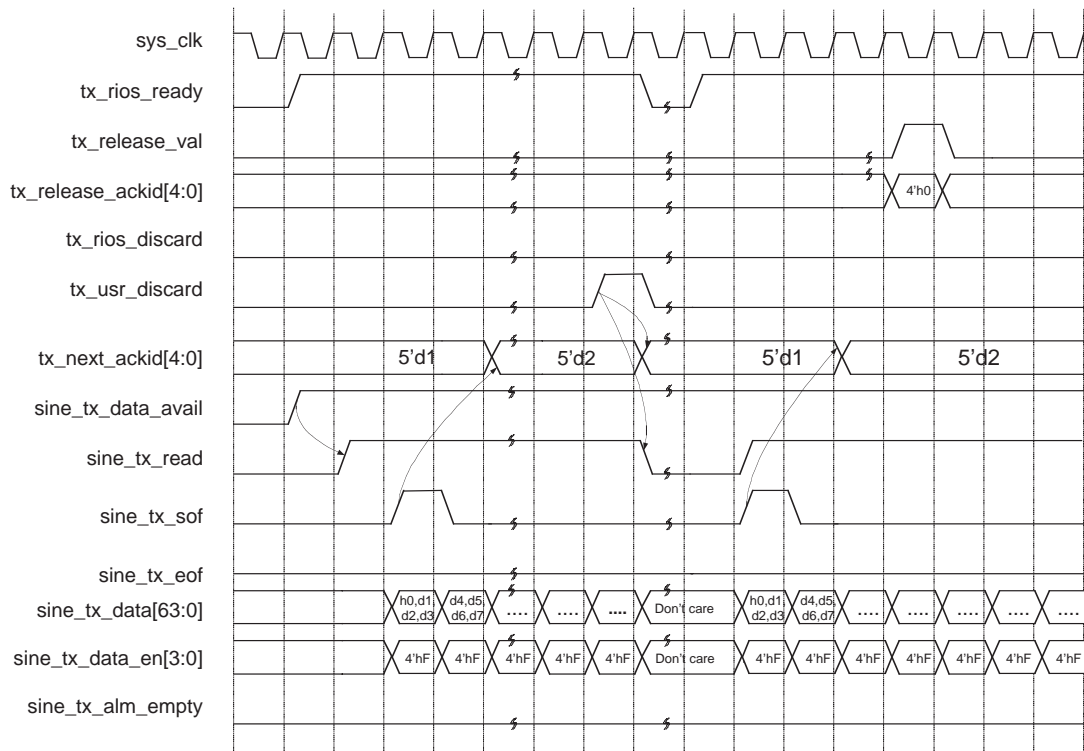
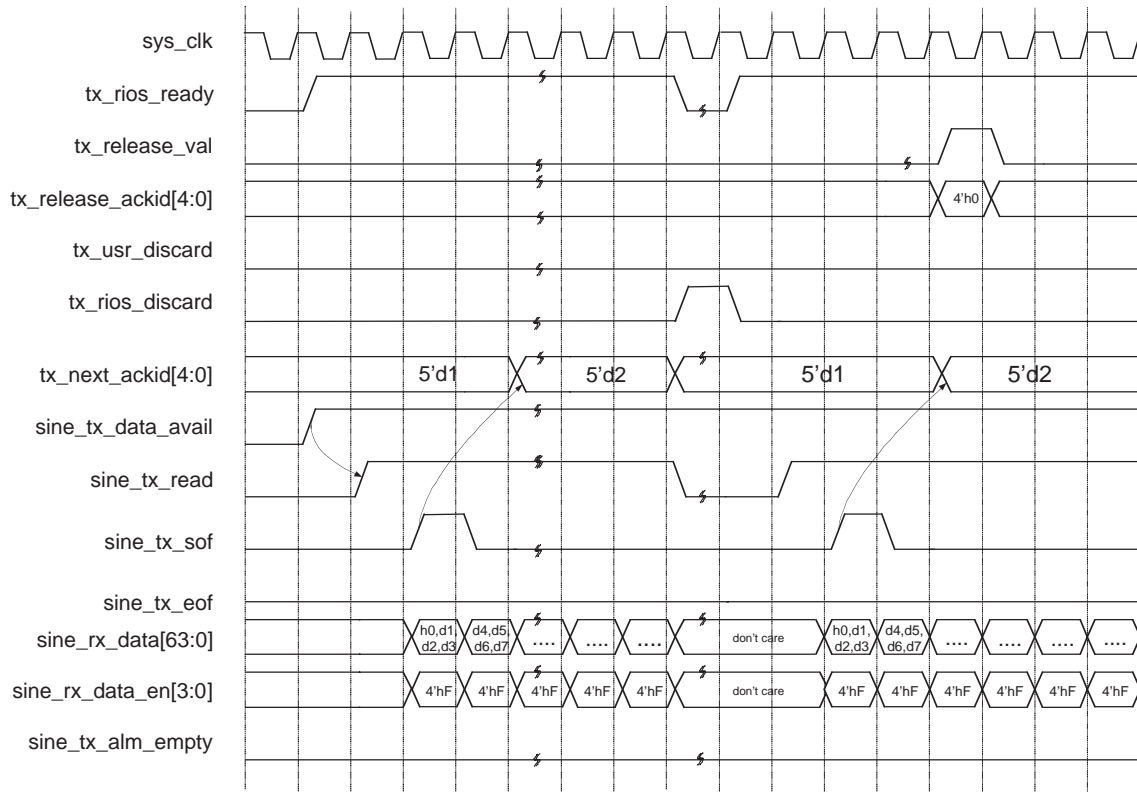

Figure 14. TX Discarding a Packet by tx_rios_discard



Receive User Interface

Figure 15. RX Transfer of Data Without Discards

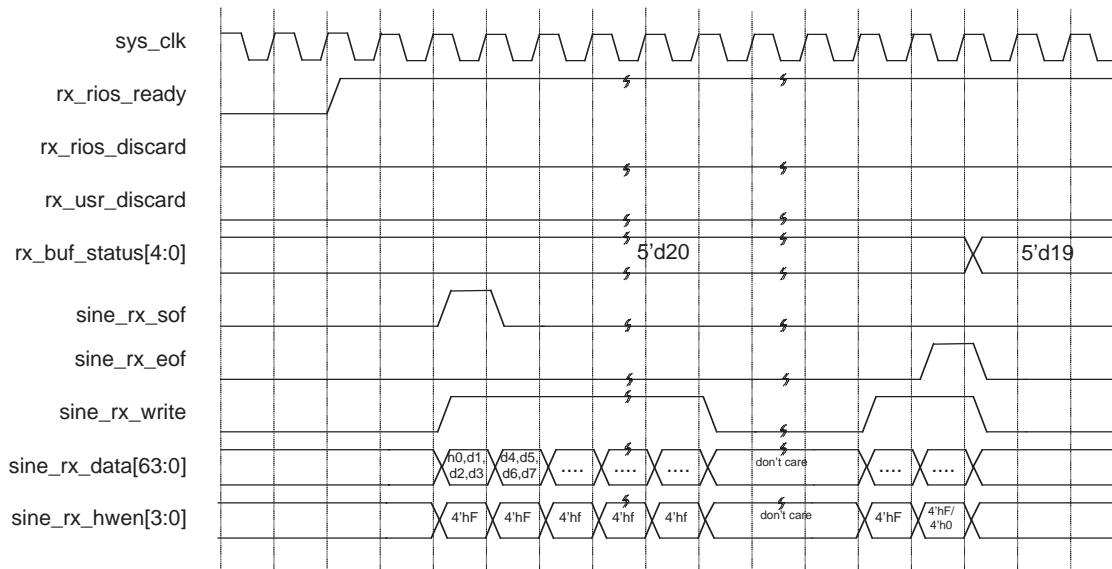

Figure 16. Discarding the Packet using rx_rios_discard

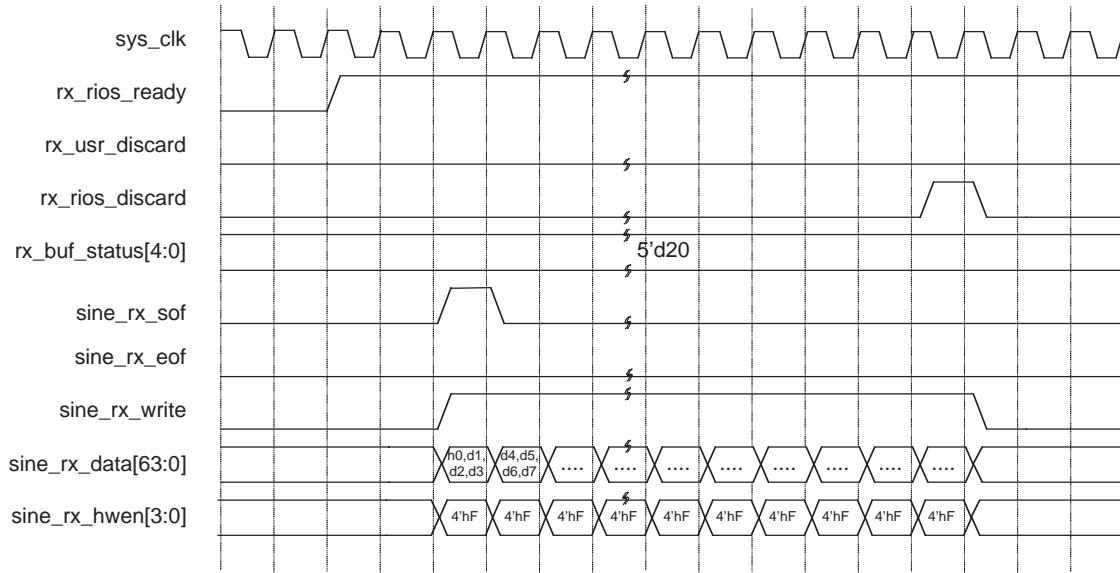
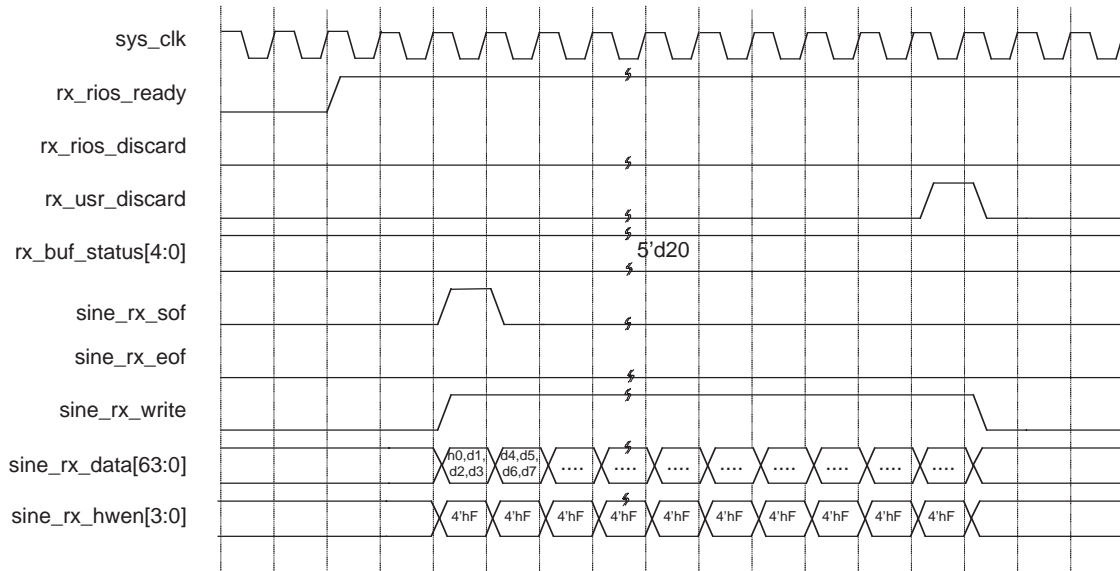
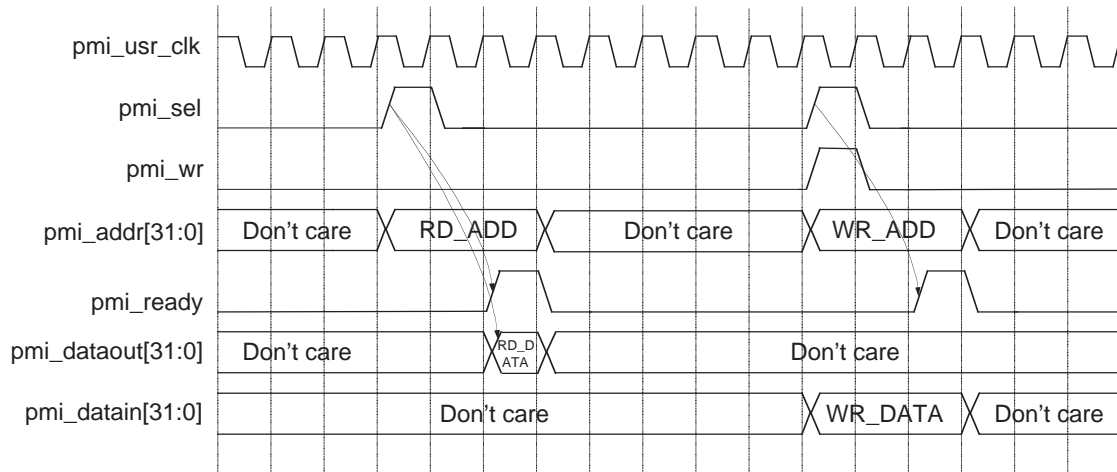

Figure 17. Discarding the Packet using rx_usr_discard



PMI Interface

Figure 18. PMI Read and Write Cycles



Signal Descriptions

Table 5 shows the signal descriptions for the input and output ports of the Serial RapidIO IP connecting to the Serial RapidIO Physical side. For a description of the signals connecting to the embedded SERDES of the ORT42G5 device (signals beginning with “um_”), please refer to the device data sheet.

Table 5. Serial RapidIO Physical Layer Interface Signal Definitions

Port Name	I/O Type	Active State	Signal Description
TX Interface			
TD	Output	—	Transmit Data. This is a unidirectional point-to-point bus carrying packet information. This bus is connected to the RD bus of the receiving device.
TD_N	Output	—	Transmit Data complements. These are the differential pairs of the TD signal.
RX Interface			
RD	Input	—	Receive Data. This is a unidirectional point-to-point bus carrying packet information. This bus is connected to the TD bus of the receiving device.
RD_N	Input	—	Receive Data complements. These are the differential pairs of the RD signal.

Table 6 shows the signal descriptions for the input and output ports of the Serial RapidIO IP connecting to the user side.

Table 6. Serial RapidIO User Interface Signal Definitions

Port Name	I/O Type	Active State	Signal Description
reset_n	Input	Low	Active low system reset signal.
sys_clk	Input	—	System Clock
RX User Interface			
rx_buf_status [4:0]	Input	—	This signal specifies the number of available packet buffers in the receiving device. Encoding value specifies the number of packet buffers the receiving device has currently available.
rx_rios_ready	Output	High	Ready signal indicating RX RapidIO-PHY is ready and that receiver initialization is complete.
rx_rios_discard	Output	High	Indicates that RX RapidIO-PHY wants to terminate the current packet being sent to the user interface.
rx_usr_discard	Input	High	Indicates that the user interface wants to terminate the current packet being received from the RX RapidIO-PHY interface.
sine_rx_data [63:0]	Output	—	Indicates that data was sent from the RX RapidIO-PHY interface to the user.
sine_rx_hwen [3:0]	Output	—	This signal indicates the valid half word of the data bus sine_rx_data of the current packet transfer.
sine_rx_sof	Output	—	SOF signal indicating the start of sine_rx_data.
sine_rx_eof	Output	—	EOF signal indicating the end of sine_rx_data.
sine_rx_write	Output	—	This signal is asserted when RX RapidIO-PHY writes the data received to the user interface FIFO.
TX User Interface			
tx_rios_ready	Output	High	Ready signal indicating TX RapidIO-PHY is ready to receive data from the user. When tx_rios_ready is de-asserted, all user interface signals are regarded as invalid input or output.
tx_next_ackid [4:0]	Output	—	Indicates that the buffer data associated with this ACKID should be sent by the user through the Generic FIFO Bridge interface.
tx_release_ackid [4:0]	Output	—	Indicates that the buffer data associated with this ACKID can be released and reused by the user interface.

Table 6. Serial RapidIO User Interface Signal Definitions (Continued)

Port Name	I/O Type	Active State	Signal Description
tx_rios_discard	Output	High	Indicates that TX RapidIO-PHY wants to terminate the current packet being received from the user interface.
tx_usr_discard	Input	High	Indicates the user interface wants to terminate the current packet being sent to the RapidIO-PHY interface.
tx_prio[1:0]	Input	—	Indicates the priority of the packet being received.
tx_release_val	Output	—	Indicates that tx_release_ackid is valid.
sine_tx_data [63:0]	Input	—	Indicates that data was received from the user interface.
sine_tx_alm_empty	Input	High	This signal is asserted when the user transmit FIFO is almost empty. The threshold is set to one 64 bit.
sine_tx_read	Output	High	This signal is asserted when the TX RapidIO PHY requests data from the user transmit FIFO.
sine_tx_sof	Input	High	This signal is asserted with the first data transferred to indicate the start of a new packet. It should be asserted for a maximum of one clock cycle.
sine_tx_eof	Input	High	This signal is asserted with the last data transferred to indicate the end of the packet.
sine_tx_data_en [3:0]	Input	—	This signal indicates the valid half word of the data bus on the last data transfer of the current packet.
sine_tx_data_avail	Input	High	This signal is asserted as long as there is one full packet or predetermined amount of data in the user transmit FIFO.
PMI Interface			
pmi_usr_clk	Input	—	Management interface clock
pmi_sel	Input	High	Management Device Select - This signal is asserted to access Management registers.
pmi_ready	Output	High	Indicates when Management is ready. This signal is asserted to indicate that Management has taken/kept the data from/to the data bus.
pmi_wr	Input	High	Management register write. Valid when pmi_sel is asserted. When this signal is low, it indicates a read.
pmi_addr[31:0]	Input	—	Management address bus for register access.
pmi_datain[31:0]	Input	—	Register Data In
pmi_dataout[31:0]	Output	—	Register Data Out
pmi_int	Output	High	Management Interrupt

User Configurable Parameters

User configurable parameters are shown below in Table 7. These parameters are configured using IPexpress™, included with Lattice's ispLEVER® design tools.

Table 7. User Configurable Parameters

Parameter	Description	Range	Default
Device Type	Target device selection	[Pre-selected] ORT42G5	[Pre-selected] ORT42G5
Phy Base Address	PMI Phy Register Base Address	0 - FFFF_FFFF	32'h0000_0000
EF_PTR (CSR Block Header0)	EF Pointer in CSR Block Header0	0-FFFF	16'h0000
Silence Timer	Silence Timer Count Value: This is the duration of the SILENT state. The duration must be long enough to ensure that the link partner detects the silence (as a loss of lane sync) and is forced to initialize but short enough that it is readily distinguished from a link break. Refer to Serial RapidIO Specification for further information on the SILENT state section 4.6.3.5	FF-FFFF	16'h00FF
Max. Packet Size in bytes	Maximum Byte Size per Packet: This sets the maximum packet size in bytes that the receiver can accept. Any packets above the maximum packet size will be discarded by the receiver	8-508	276
Receive Nop Limit	Number of Maximum Idle Control Symbols to be Received: This sets a limit on the maximum number of IDLE control symbols that can be received within a packet. Any number of idles above the maximum size will cause the packet to be discarded by the receiver	1-FF	FF

Figure 19. Serial RapidIO Parameter Configuration Dialog Box

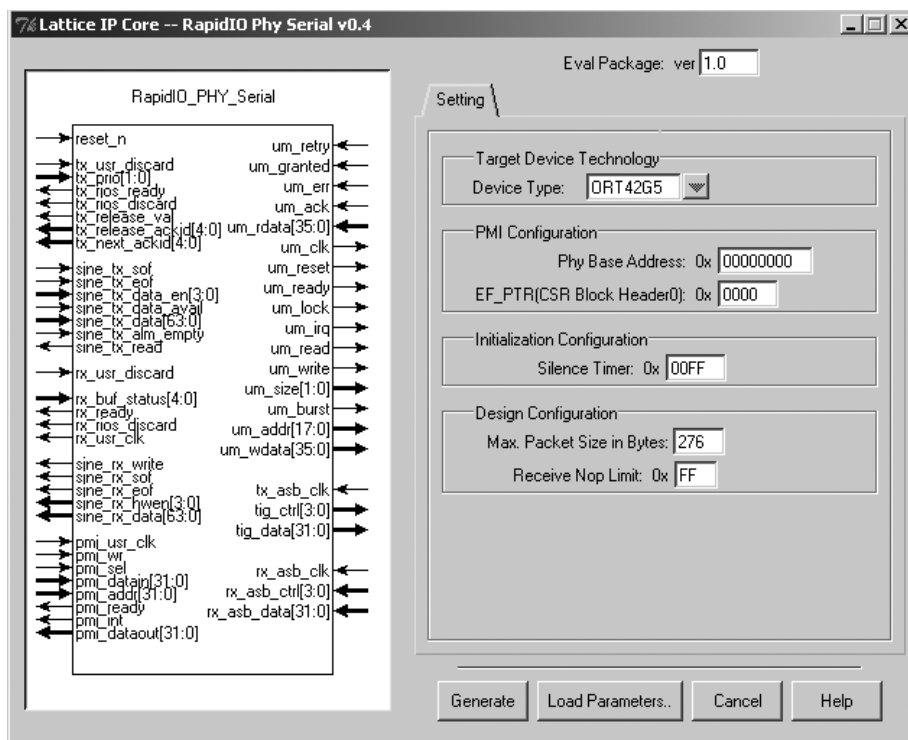

References

- ispLEVER® Software Online Help Manual
- IP Evaluation Tutorials

Technical Support Assistance

Hotline: 1-800-LATTICE (North America)
 +1-503-268-8001 (Outside North America)
 e-mail: techsupport@latticesemi.com
 Internet: www.latticesemi.com

Appendix for ORCA[®] Series 4 FPSCs – ORT42G5

Table 8. Performance and Resource Utilization¹

Name of Parameter File	ORCA 4 ² PFUs	LUTs ²	Registers ²	EBR	PIO ²	f _{MAX} sys_clk and pmi_usr_clk (MHz)
rio_seri_t42g5_1_001.lpc	996	4386	4232	23	178	39.0625

1. Performance and utilization characteristics are generated using an ORT42G5-2BM484 in Lattice's ispLEVER 3.1 software. When using this IP core in a different density, package, speed, or grade within ORCA 4 family, performance and utilization may vary.

2. Performance and utilization characteristics are counted based on the utilization of the top level module which includes `rios_smi` module.

Supplied Netlist Configurations

The Ordering Part Number (OPN) for all configurations of this core is RIO-SERI-T42G5-N1. Table 8 lists the netlists available as Evaluation Packages for the ORCA Series 4 FPSC devices, which can be downloaded from the Lattice website at www.latticesemi.com.

You can use the IPexpress software tool to help generate new configurations of this IP core. IPexpress is the Lattice IP configuration utility, and is included as a standard feature of the ispLEVER design tools. Details regarding the usage of IPexpress can be found in the IPexpress and ispLEVER help system. For more information on the ispLEVER design tools, visit the Lattice web site at www.latticesemi.com/software.



Компания «ЭлектроПласт» предлагает заключение долгосрочных отношений при поставках импортных электронных компонентов на взаимовыгодных условиях!

Наши преимущества:

- Оперативные поставки широкого спектра электронных компонентов отечественного и импортного производства напрямую от производителей и с крупнейших мировых складов;
- Поставка более 17-ти миллионов наименований электронных компонентов;
- Поставка сложных, дефицитных, либо снятых с производства позиций;
- Оперативные сроки поставки под заказ (от 5 рабочих дней);
- Экспресс доставка в любую точку России;
- Техническая поддержка проекта, помощь в подборе аналогов, поставка прототипов;
- Система менеджмента качества сертифицирована по Международному стандарту ISO 9001;
- Лицензия ФСБ на осуществление работ с использованием сведений, составляющих государственную тайну;
- Поставка специализированных компонентов (Xilinx, Altera, Analog Devices, Intersil, Interpoint, Microsemi, Aeroflex, Peregrine, Syfer, Eurofarad, Texas Instrument, Miteq, Cobham, E2V, MA-COM, Hittite, Mini-Circuits, General Dynamics и др.);

Помимо этого, одним из направлений компании «ЭлектроПласт» является направление «Источники питания». Мы предлагаем Вам помощь Конструкторского отдела:

- Подбор оптимального решения, техническое обоснование при выборе компонента;
- Подбор аналогов;
- Консультации по применению компонента;
- Поставка образцов и прототипов;
- Техническая поддержка проекта;
- Защита от снятия компонента с производства.



Как с нами связаться

Телефон: 8 (812) 309 58 32 (многоканальный)

Факс: 8 (812) 320-02-42

Электронная почта: org@eplast1.ru

Адрес: 198099, г. Санкт-Петербург, ул. Калинина, дом 2, корпус 4, литера А.