



FEATURES

- 22 differential HSTL (low-voltage swing) output pairs
- HSTL outputs drive 50Ω to ground with no offset voltage
- 3.3V core supply, 1.8V output supply for reduced power
- LVPECL and HSTL inputs
- Low part-to-part skew (200ps max.)
- Low pin-to-pin skew (50ps max.)
- Triple-buffered output enable (OE)
- -40°C to +85°C temperature range
- Available in a 64-pin EPAD-TQFP

APPLICATIONS

- High-performance PCs
- Workstations
- Parallel processor-based systems
- Other high-performance computing
- Communications

LOGIC SYMBOL

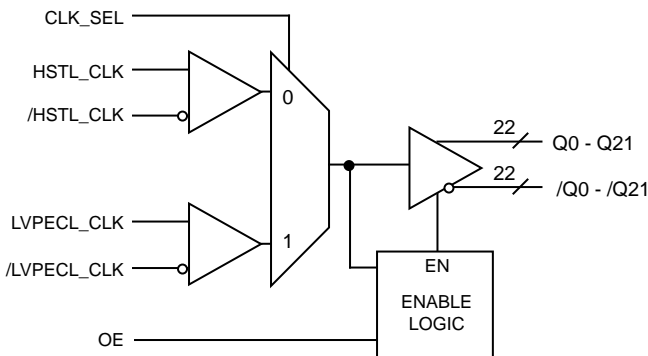

Precision Edge®

DESCRIPTION

The SY89823L is a high-performance bus clock driver with 22 differential High-Speed Transceiver Logic (HSTL), 1.5V compatible output pairs. The device is designed for use in low-voltage (3.3V/1.8V) applications that require a large number of outputs to drive precisely aligned, ultra-low skew signals to their destination. The input is multiplexed from either HSTL or Low-Voltage Positive-Emitter-Coupled Logic (LVPECL) by the CLK_SEL pin.

The Output Enable (OE) is synchronous and triple-buffered so that the outputs will only be enabled/disabled when they are already in the LOW state. This avoids any potential of generating a runt clock pulse when the device is enabled/disabled, as can occur with an asynchronous control. The triple-buffering feature provides a three-clock delay from the time the OE input is asserted/de-asserted to when the clock appears at the outputs.

The SY89823L features low pin-to-pin skew (50ps max.) and low part-to-part skew (200ps max.), performance previously unachievable in a standard product having such a high number of outputs. The SY89823L is available in a single, space-saving package, enabling a lower overall cost solution.

All support documentation can be found on Micrel's web site at: www.micrel.com.

TRUTH TABLE

OE ⁽¹⁾	CLK_SEL	Q ₀ -Q ₂₁	/Q ₀ -/Q ₂₁
0	0	LOW	HIGH
0	1	LOW	HIGH
1	0	HSTL_CLK	/HSTL_CLK
1	1	LVPECL_CLK	/LVPECL_CLK

Note:

1. The output enable (OE) signal is synchronized with the low level of the HSTL_CLK and LVPECL_CLK signal.

TYPICAL PERFORMANCE

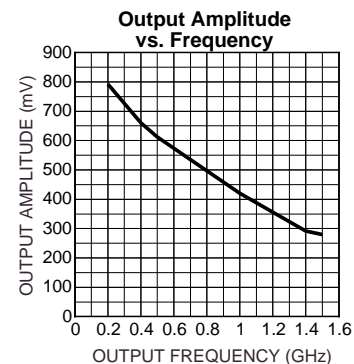

PACKAGE/ORDERING INFORMATION

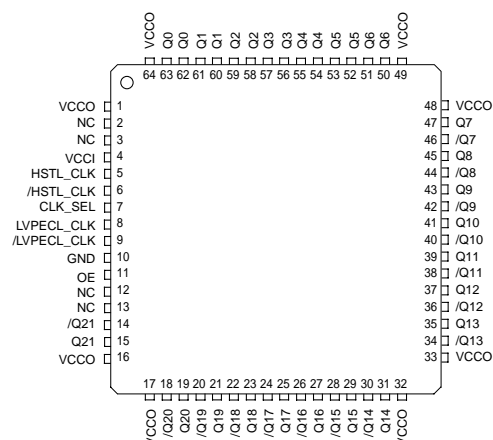

64-Pin EPAD-TQFP (H64-1)

Ordering Information⁽¹⁾

Part Number	Package Type	Operating Range	Package Marking	Lead Finish
SY89823LHC	H64-1	Commercial	SY89823LHC	Sn-Pb
SY89823LHCTR ⁽²⁾	H64-1	Commercial	SY89823LHC	Sn-Pb
SY89823LHZ ⁽³⁾	H64-1	Commercial	SY89823LHZ with Pb-Free bar-line indicator	Pb-Free Matte-Sn
SY89823LHZTR ^(2, 3)	H64-1	Commercial	SY89823LHZ with Pb-Free bar-line indicator	Pb-Free Matte-Sn
SY89823LHI	H64-1	Industrial	SY89823LHI with Pb-Free bar-line indicator	Sn-Pb
SY89823LHITR ^(2, 3)	H64-1	Industrial	SY89823LHI with Pb-Free bar-line indicator	Sn-Pb
SY89823LHY ⁽³⁾	H64-1	Industrial	SY89823LHY with Pb-Free bar-line indicator	Pb-Free Matte-Sn
SY89823LHYTR ^(2, 3)	H64-1	Industrial	SY89823LHY with Pb-Free bar-line indicator	Pb-Free Matte-Sn

Notes:

1. Contact factory for die availability. Dice are guaranteed at T_A = 25°C, DC electricals only.
2. Tape and Reel.
3. Pb-Free package recommended for new designs.

PIN DESCRIPTION

Pin Number	Pin Name	Type	Pin Function
5, 6	HSTL_CLK, /HSTL_CLK	HSTL Input	Differential clock input selected by CLK_SEL. Can be left floating if not selected. Floating input, if selected, produces an indeterminate output. HSTL input signal requires external termination 50Ω to GND.
8, 9	LVPECL_CLK, /LVPECL_CLK	LVPECL Input	Differential clock input selected by CLK_SEL. Can be left floating. Floating input, if selected, produces a LOW at the output. Requires external termination. 75kΩ pull-up.
7	CLK_SEL	LVTTL Input	Selects HSTL_CLK input when LOW and LVPECL_CLK output when HIGH. 11kΩ pull-up. Default condition selects LVPECL_CLK if left open.
11	OE	LVTTL Input	Enable input synchronized internally to prevent glitching of the Q0-Q21 and /Q0-/Q21 outputs. Must be a minimum of three clock periods wide if synchronous with the CLK inputs and must meet the t _S and t _H requirements (refer to “AC Electrical Characteristics” section). If asynchronous, must be a minimum of four clock periods wide. 11kΩ pull-up.
63, 61, 59, 57, 55, 53 51, 47, 45, 43, 41, 39 37, 35, 31, 29, 27 25, 23, 21, 19, 15	Q0-Q21	HSTL Output	Differential clock outputs from HSTL_CLK when CLK_SEL = LOW and LVPECL outputs when CLK_SEL = HIGH. HSTL outputs must be terminated with 50Ω to GND. Q0-Q21 outputs are static LOW when OE = LOW. Unused output pairs may be left floating.
62, 60, 58, 56, 54, 52 50, 46, 44, 42, 40, 38 36, 34, 30, 28, 26 24, 22, 20, 18, 14	/Q0-/Q21	HSTL Output	Differential clock outputs from HSTL_CLK when CLK_SEL = LOW and LVPECL outputs when CLK_SEL = HIGH. HSTL outputs must be terminated with 50Ω to GND. /Q0-/Q21 outputs are static HIGH when OE = LOW. Unused output pairs may be left floating.
4	VCCI	VCC Core	Core V _{CC} connected to 3.3V supply. Bypass with 0.1μF in parallel with Power 0.01μF low ESR capacitors as close to V _{CCI} pins as possible.
1, 16, 17, 32, 33, 48, 49, 64	VCCO	VCC Output Power	Output Buffer V _{CC} connected to 1.8V supply. Bypass with 0.1μF in parallel with 0.01μF low ESR capacitors as close to V _{CCO} pin as possible. All V _{CCO} pins should be connected together on the PCB.
10	GND, Exposed Pad		Ground pin and exposed pad must be connected to the same ground plane.
2, 3, 12, 13	NC		No Connect.

Absolute Maximum Ratings⁽¹⁾

Supply Voltage (V_{IN})	-0.5V to V_{CCI}
V_{CC} Pin Potential to Ground Pin	
V_{CCI}, V_{CCO}	-0.5V to +4.0V
DC Output Current, Output HIGH (I_{OUT})	-50mA
Lead Temperature (soldering, 20 sec.)	260°C
Storage Temperature (T_S)	-65°C to +150°C

Operating Ratings⁽²⁾

Supply Voltage	
V_{CCI}	+3.15V to +3.45V
V_{CCO}	+1.6V to +2.0V
Ambient Temperature (T_A)	-40°C to +85°C
Package Thermal Resistance ⁽³⁾	
EPAD-TQFP (θ_{JA}) with Die attach soldered to GND	
Still-Air	23°C/W
200lfpm	18°C/W
500lfpm	15°C/W
with Die attach NOT soldered to GND	
Still-Air	44°C/W
200lfpm	36°C/W
500lfpm	30°C/W
EPAD-TQFP (θ_{JC})	4.3°C/W

DC ELECTRICAL CHARACTERISTICS⁽⁴⁾

Power Supply $T_A = -40^\circ\text{C}$ to $+85^\circ\text{C}$, unless otherwise stated.

Symbol	Parameter	Condition	Min	Typ	Max	Units
V_{CCI}	V_{CC} Core		3.15	3.3	3.45	V
V_{CCO}	V_{CC} Output		1.6	1.8	2.0	V
I_{CCI}	I_{CC} Core	Max V_{CC} , no load	—	115	170	mA

HSTL $V_{CCI} = 3.3\text{V} \pm 5\%$; $V_{CCO} = 1.8\text{V} \pm 10\%$; $R_L = 50\Omega$ to GND; $T_A = -40^\circ\text{C}$ to $+85^\circ\text{C}$, unless otherwise stated.

Symbol	Parameter	Condition	Min	Typ	Max	Units
V_{OH}	Output HIGH Voltage		1.0	—	1.2	V
V_{OL}	Output LOW Voltage		0.2	—	0.4	V
V_{IH}	Input HIGH Voltage		$V_X + 0.1$	—	1.6	V
V_{IL}	Input LOW Voltage		-0.3	—	$V_X - 0.1$	V
V_X	Input Crossover Voltage		0.68	—	0.9	V
I_{IH}	Input HIGH Current		+20	—	-350	μA
I_{IL}	Input LOW Current		—	—	-500	μA

LVPECL $V_{CCI} = 3.3\text{V} \pm 5\%$; $V_{CCO} = 1.8\text{V} \pm 10\%$; $T_A = -40^\circ\text{C}$ to $+85^\circ\text{C}$, unless otherwise stated.

Symbol	Parameter	Condition	Min	Max	Units
V_{IH}	Input HIGH Voltage		$V_{CCI} - 1.165$	$V_{CCI} - 0.880$	V
V_{IL}	Input LOW Voltage		$V_{CCI} - 1.810$	$V_{CCI} - 1.475$	V
I_{IH}	Input HIGH Current		—	+150	μA
I_{IL}	Input LOW Current		0.5	—	μA

Notes:

1. Permanent device damage may occur if the ratings in the "Absolute Maximum Ratings" section are exceeded. This is a stress rating only and functional operation is not implied at conditions other than those detailed in the operational sections of this data sheet. Exposure to absolute maximum ratings conditions for extended periods may affect device reliability.
2. The data sheet limits are not guaranteed if the device is operated beyond the operating ratings.
3. Valid for 4-layer board.
4. The circuit is designed to meet the DC specifications shown in the above table after thermal equilibrium has been established.

DC ELECTRICAL CHARACTERISTICS⁽⁵⁾LVCMOS/LVTTL $V_{CCI} = 3.3V \pm 5\%$; $V_{CCO} = 1.8V \pm 10\%$; $T_A = -40^\circ\text{C}$ to $+85^\circ\text{C}$, unless otherwise stated.

Symbol	Parameter	Condition	Min	Typ	Max	Units
V_{IH}	Input HIGH Voltage		2.0	—	—	V
V_{IL}	Input LOW Voltage		—	—	0.8	V
I_{IH}	Input HIGH Current		+20	—	-250	μA
I_{IL}	Input LOW Current		—	—	-600	μA

AC ELECTRICAL CHARACTERISTICS⁽⁶⁾ $V_{CCI} = 3.3V \pm 5\%$; $V_{CCO} = 1.8V \pm 10\%$; All outputs loaded with 50Ω to GND; $T_A = -40^\circ\text{C}$ to $+85^\circ\text{C}$, unless otherwise stated.

Symbol	Parameter	Condition	Min	Typ	Max	Units	
f_{MAX}	Maximum Operating Frequency	$V_{OUT} \geq 450\text{mV}$	500	—	—	MHz	
t_{pd}	Propagation Delay	CLK-to-Q	Note 7	0.8	—	1.3	ns
		SEL-to-Q	Note 7	0.8	1.2	1.7	ns
t_{SKEW}	Within-Device Skew	Note 8	—	—	50	ps	
t_{SKPP}	Part-to-Part Skew	Note 9	—	—	200	ps	
V_{pp}	Minimum Input Swing LVPECL_CLK	Note 10	600	—	—	mV	
V_{CMR}	Common Mode Range LVPECL_CLK	Note 11	-1.5	—	-0.4	V	
t_S	OE Set-Up Time	Note 12	1.0	—	—	ns	
t_H	OE Hold Time		0.5	—	—	ns	
t_r, t_f	Output Rise/Fall Time (20% – 80%)		300	—	700	ps	
t_{JITTER}	Cycle-to-Cycle Jitter	Note 13			1	ps_{RMS}	

Notes:

- The circuit is designed to meet the DC specifications shown in the above table after thermal equilibrium has been established.
- High-frequency AC-parameters are guaranteed by design and characterization.
- Differential propagation delay is defined as the delay from the crossing point of the differential input signals to the crossing point of the differential output signals.
- The within-device skew is defined as the worst case difference between any two similar delay paths within a single device operating at the same voltage and temperature.
- The part-to-part skew is defined as the absolute worst case difference between any two delay paths on any two devices operating at the same voltage and temperature.
- The $V_{pp}(\text{min})$ is defined as the minimum input differential voltage which will cause no increase in the propagation delay.
- V_{CMR} is defined as the range within which the V_{IH} level may vary, with the device still meeting the propagation delay specification. The numbers in the table are referenced to V_{CCI} . The V_{IL} level must be such that the peak-to-peak voltage is less than 1.0V and greater than or equal to $V_{pp}(\text{min})$. The lower end of the CMR range varies 1:1 with V_{CCI} . The $V_{CMR}(\text{min})$ will be fixed at $3.3V - |V_{CMR}(\text{min})|$.
- OE set-up time is defined with respect to the rising edge of the clock. OE HIGH to LOW transition ensures outputs remain disabled during the next clock cycle. OE LOW-to-HIGH transition enables normal operation of the next input clock.
- Cycle-to-cycle jitter definition: The variation of periods between adjacent cycles, $T_n - T_{n-1}$ where T is the time between rising edges of the output signal.

TIMING DIAGRAMS

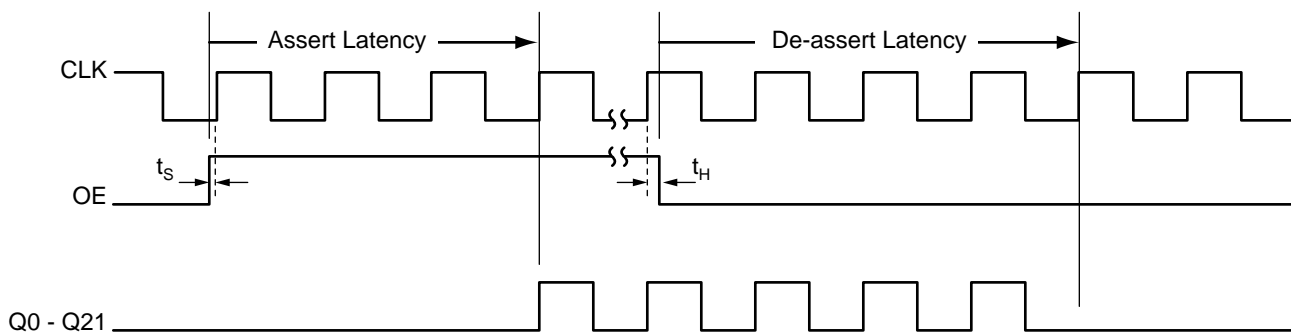

Notes:

1. The OE input signal must be a minimum of 3 clock periods with width.
2. The internal enable is asserted and de-asserted on the falling edge of clock.
3. The internal enable occurs 2.5 clock cycles (plus the set-up time of OE with the rising edge of clock) after the rising edge of the external OE.
4. If OE does not meet the t_s of t_h specifications as in asynchronous applications, OE must be a minimum of 4 clock periods in width.

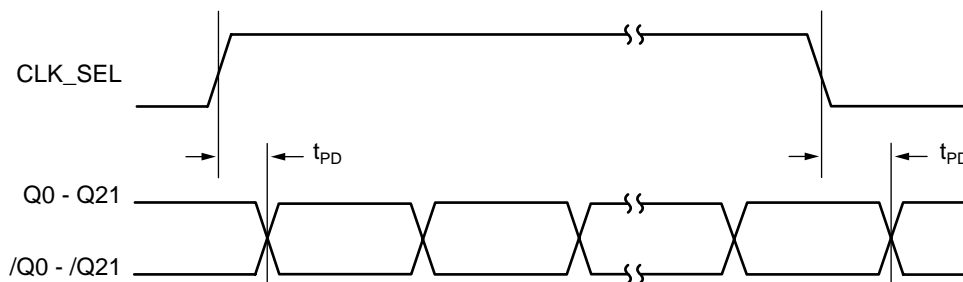
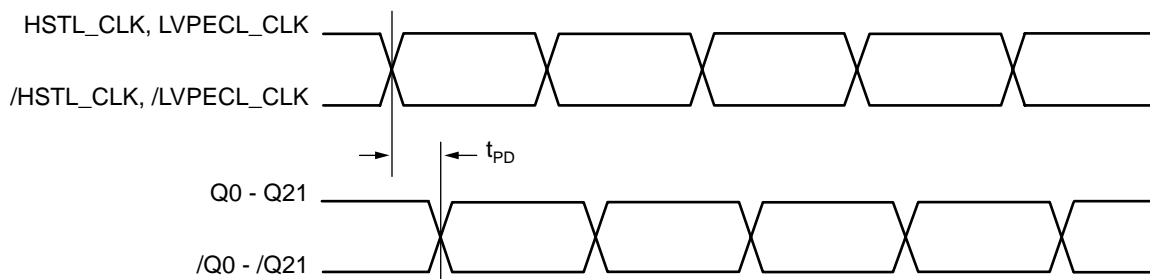

TYPICAL OPERATING CHARACTERISTICS

$V_{CCI} = 3.6V$, $V_{CCO} = 2.0V$, $T_A = 25^\circ C$, unless otherwise stated.

200MHz Output

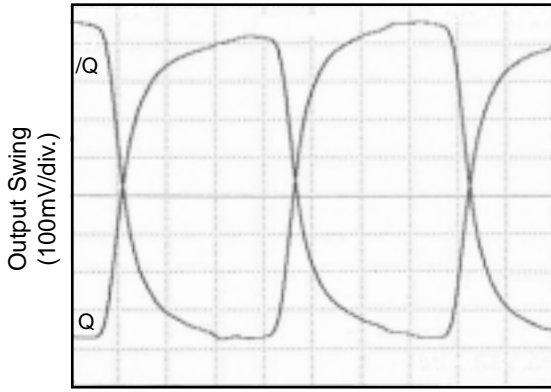

TIME (700ps/div)

400MHz Output

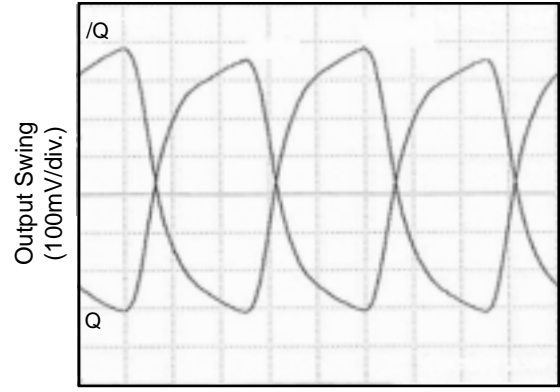

TIME (500ps/div)

500MHz Output

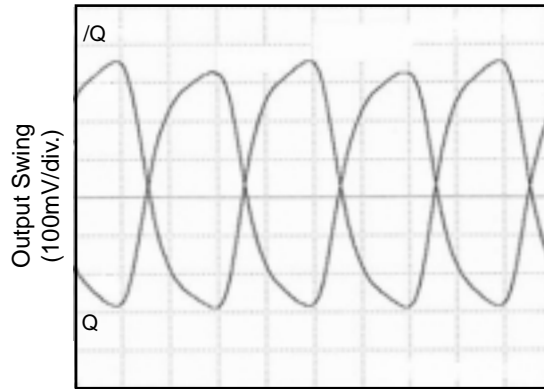

TIME (500ps/div)

LVPECL/HSTL INPUTS

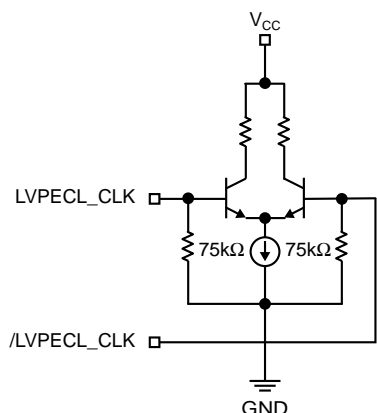

Figure 1. Simplified LVPECL Input Stage

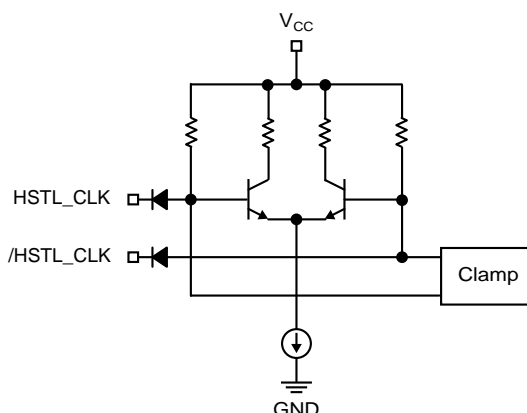

Figure 2. Simplified HSTL Input Stage

HSTL OUTPUTS

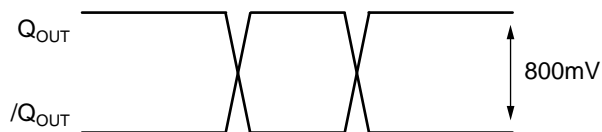

Figure 3. Output Driver Signal Levels (Single-Ended)

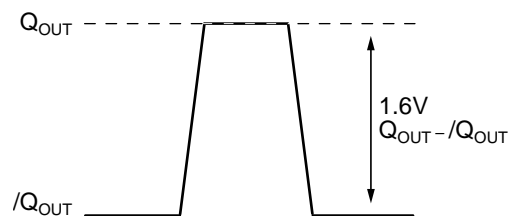
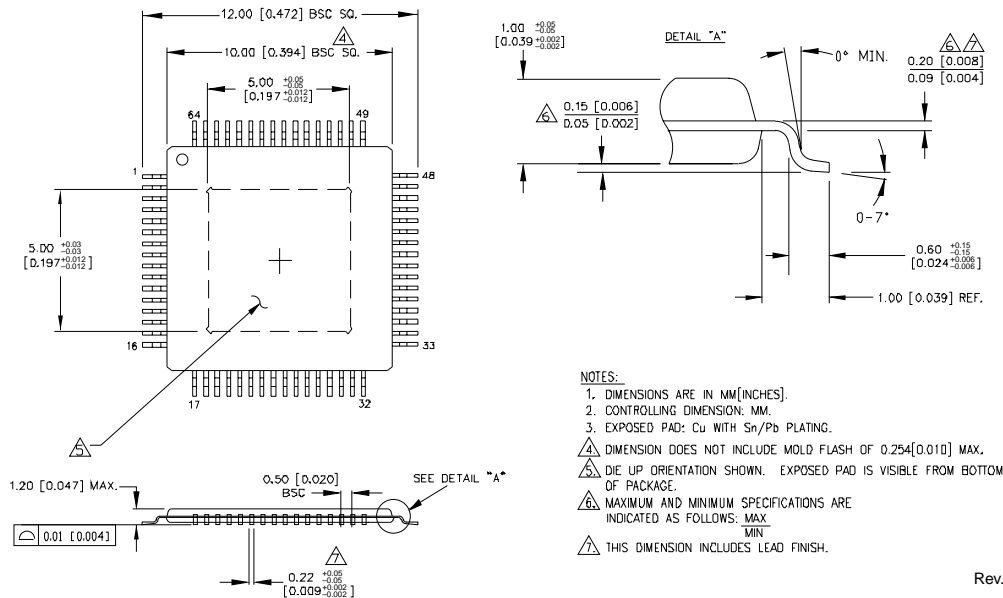

Figure 4. Output Driver Signal Levels (Differential)

RELATED MICREL PRODUCTS AND SUPPORT DOCUMENTATION

Part Number	Function	Data Sheet Link
SY89809L	3.3V 1:9 High-Performance, Low-Voltage Bus Clock Driver	http://www.micrel.com/product-info/products/sy89809l.shtml
SY89808L	3.3V, 500MHz, 1:9 Differential HSTL (1.5V) Fanout Buffer Translator	http://www.micrel.com/product-info/products/sy89808l.shtml
	Exposed Pad Application Note	http://www.amkor.com/products/notes_papers/epad.pdf
HBW Solutions	New Products and Applications	http://www.micrel.com/product-info/products/solutions.shtml
MIC3775	750mA μ Cap Low-Voltage Low-Dropout Regulator	http://www.micrel.com/product-info/products/mic3775.shtml

64-PIN EPAD-TQFP (DIE UP) (H64-1)



Rev. 02

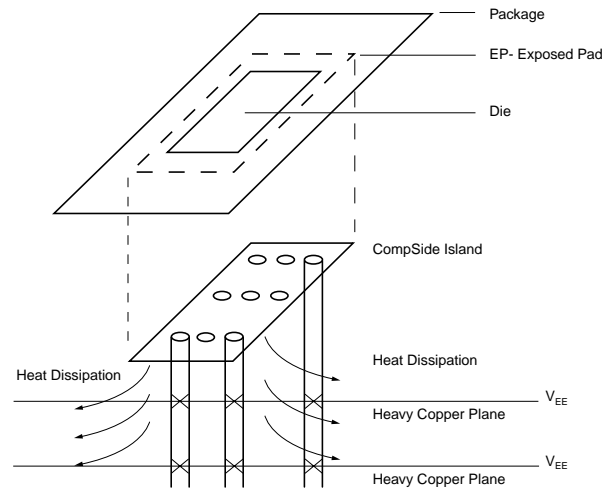

**PCB Thermal Consideration for 64-Pin EPAD-TQFP Package
(Always solder or equivalent the exposed pad to the PCB)**

Package Notes:

1. Package meets Level 2 qualification.
2. All parts are dry-packaged before shipment.
3. Exposed pads must be soldered to a ground for proper thermal management.

MICREL, INC. 2180 FORTUNE DRIVE SAN JOSE, CA 95131 USA

TEL + 1 (408) 944-0800 FAX + 1 (408) 944-0970 WEB <http://www.micrel.com>

The information furnished by Micrel in this data sheet is believed to be accurate and reliable. However, no responsibility is assumed by Micrel for its use. Micrel reserves the right to change circuitry and specifications at any time without notification to the customer.

Micrel Products are not designed or authorized for use as components in life support appliances, devices or systems where malfunction of a product can reasonably be expected to result in personal injury. Life support devices or systems are devices or systems that (a) are intended for surgical implant into the body or (b) support or sustain life, and whose failure to perform can be reasonably expected to result in a significant injury to the user. A Purchaser's use or sale of Micrel Products for use in life support appliances, devices or systems is at Purchaser's own risk and Purchaser agrees to fully indemnify Micrel for any damages resulting from such use or sale.

© 2005 Micrel, Incorporated.



Компания «ЭлектроПласт» предлагает заключение долгосрочных отношений при поставках импортных электронных компонентов на взаимовыгодных условиях!

Наши преимущества:

- Оперативные поставки широкого спектра электронных компонентов отечественного и импортного производства напрямую от производителей и с крупнейших мировых складов;
- Поставка более 17-ти миллионов наименований электронных компонентов;
- Поставка сложных, дефицитных, либо снятых с производства позиций;
- Оперативные сроки поставки под заказ (от 5 рабочих дней);
- Экспресс доставка в любую точку России;
- Техническая поддержка проекта, помощь в подборе аналогов, поставка прототипов;
- Система менеджмента качества сертифицирована по Международному стандарту ISO 9001;
- Лицензия ФСБ на осуществление работ с использованием сведений, составляющих государственную тайну;
- Поставка специализированных компонентов (Xilinx, Altera, Analog Devices, Intersil, Interpoint, Microsemi, Aeroflex, Peregrine, Syfer, Eurofarad, Texas Instrument, Miteq, Cobham, E2V, MA-COM, Hittite, Mini-Circuits, General Dynamics и др.);

Помимо этого, одним из направлений компании «ЭлектроПласт» является направление «Источники питания». Мы предлагаем Вам помощь Конструкторского отдела:

- Подбор оптимального решения, техническое обоснование при выборе компонента;
- Подбор аналогов;
- Консультации по применению компонента;
- Поставка образцов и прототипов;
- Техническая поддержка проекта;
- Защита от снятия компонента с производства.



Как с нами связаться

Телефон: 8 (812) 309 58 32 (многоканальный)

Факс: 8 (812) 320-02-42

Электронная почта: org@eplast1.ru

Адрес: 198099, г. Санкт-Петербург, ул. Калинина, дом 2, корпус 4, литера А.