

**Mini-Mac Applicator
Rear Feed**

**Application Tooling
Specification Sheet**

Order No. 63802-6200

FEATURES

- Quick set-up time; plus the crimp height, track and feed adjustments can be preset in applicator
- Conductor and insulation rings allow quick adjustment for conductor and insulation diameter change
- Applicator designed to industry standard mounting and shut height 135.80mm (5.346")
- Directly adapts to most automatic wire processing machines

SCOPE

Products: Flag InsulKrimp™ Quick Disconnect Female Terminals, 18-22 AWG.

Terminal Order No.	Terminal Eng. No.	Wire Size		Tab Size		Insulation Diameter		Strip Length	
		AWG	mm ²	mm	In.	mm	In.	mm	In.
19007-0007	AA-2220XZ	18-22	0.80-0.35	6.35 by 0.81	.250 by .032	6.10	.240	8.70	.344
19007-0008	AA-2220Z	18-22	0.80-0.35	6.35 by 0.81	.250 by .032	4.44	.175	8.70	.344
19007-0013	AA-2222XZ	18-22	0.80-0.35	4.75 by 0.51	.187 by .020	6.10	.240	8.70	.344
19007-0014	AA-2222Z	18-22	0.80-0.35	4.75 by 0.51	.187 by .020	4.44	.175	8.70	.344
19007-0019	AA-2223XZ	18-22	0.80-0.35	4.75 by 0.81	.187 by .032	6.10	.240	8.70	.344
19007-0020	AA-2223Z	18-22	0.80-0.35	4.75 by 0.81	.187 by .032	4.44	.175	8.70	.344

DEFINITION OF TERMS

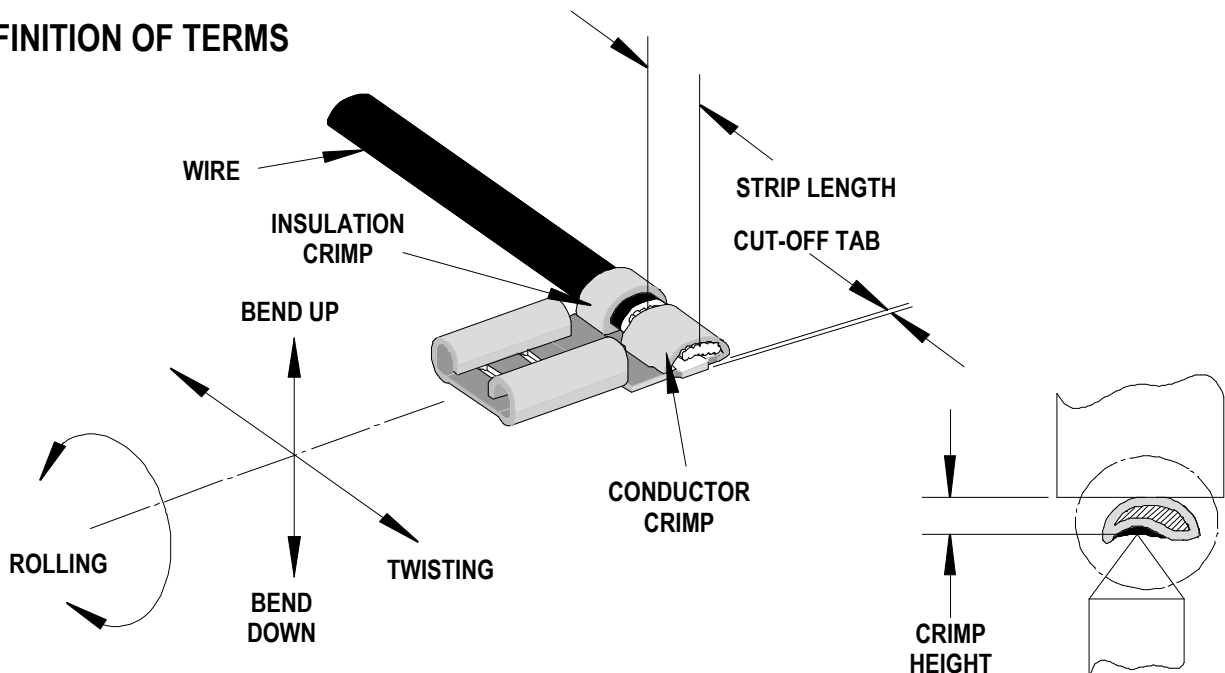

The above terminal drawing is a generic terminal representation. It is not an image of a terminal listed in the scope.

CRIMP SPECIFICATIONS

Terminal Order No.	Terminal Eng. No.	Wire Size		Conductor Crimp Height						Pull Force Minimum	
				Mean		Go		No Go			
		AWG	mm ²	mm	In.	mm	In.	mm	In.	N	Lb.
19007-0007	AA-2220XZ	18	0.80	1.65	.065	1.60	.063	1.70	.067	89.0	20.0
		20	0.50							57.9	13.0
		22	0.35							35.6	8.0
19007-0008	AA-2220Z	18	0.80	1.65	.065	1.60	.063	1.70	.067	89.0	20.0
		20	0.50							57.9	13.0
		22	0.35							35.6	8.0
19007-0013	AA-2222XZ	18	0.80	1.65	.065	1.60	.063	1.70	.067	89.0	20.0
		20	0.50							57.9	13.0
		22	0.35							35.6	8.0
19007-0014	AA-2222Z	18	0.80	1.65	.065	1.60	.063	1.70	.067	89.0	20.0
		20	0.50							57.9	13.0
		22	0.35							35.6	8.0
19007-0019	AA-2223XZ	18	0.80	1.65	.065	1.60	.063	1.70	.067	89.0	20.0
		20	0.50							57.9	13.0
		22	0.35							35.6	8.0
19007-0020	AA-2223Z	18	0.80	1.65	.065	1.60	.063	1.70	.067	89.0	20.0
		20	0.50							57.9	13.0
		22	0.35							35.6	8.0

Seam

Seam shall not be open and no wire allowed out of the crimping

*** Tool Qualification Notes:**

1. Pull Force should be measured with no influence from the insulation crimp.
2. The above specifications are guidelines to an optimum crimp.

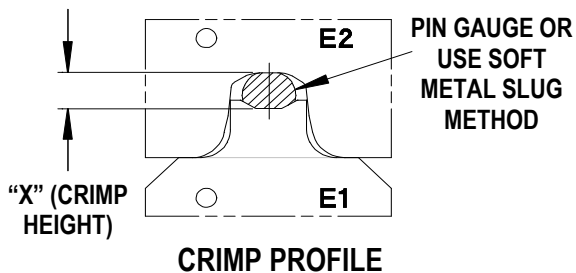

Use gauge pins or soft metal slug (solder) method to measure the "X" dimension. Verify tooling crimp height calibration by referring to the Go/No Go dimensions shown in the chart below.

Molex does not sell gauge pins contact your local industrial supplier.

PARTS LIST

Rear Feed Applicator 63802-6200				
Item	Order No	Engineering No.	Description	Quantity
Perishable Tooling				
	63802-6270	63802-6270	Tool Kit (All "Y" Items)	REF
1	63801-5511	63801-5511	Conductor Punch (Upper Die)	1 Y
2	19230-0086	24854-23	Conductor Anvil (Indenter Die)	1 Y
3	19229-0120	23650-43	Cutter Housing	1 Y
4	19229-0121	23650-44	Cutter Plunger	1 Y
Other Components				
5	19229-0095	23650-45	Cutter Back Plate	1
6	19230-0038	24854-08	Feed Finger	1
7	19230-0101	24854-09	Guide Rail	1
8	19250-0004	24854-25	Guide and Hold Down	1
9	19250-0038	24855-23	Compression Spring	1
10	63801-2685	63801-2685	Terminal Drag Assembly	1
11	63801-7701	63801-7701	Cutter Striker	1
12	63803-5134	63803-5134	Conductor Bushing	1
Frame				
13	19230-0084	24854-05	Slide (Terminal Track)	1
14	63801-2600	63801-2600	Rear Feed Frame	1
15	63801-2603	63801-2603	Base	1
Hardware				
16	N/A	N/A	M3 by 10 Long SHCS	2**
17	N/A	N/A	M4 by 8 Long SHCS	6**
18	N/A	N/A	M4 by 10 Long BHCS	2**
19	N/A	N/A	M4 by 12 Long SHCS	2**
20	N/A	N/A	M6 by 10 Long BHCS	6**
21	N/A	N/A	M8 by 25 Long BHCS	1**
22	N/A	N/A	M8 Flat Washer	1**
23	N/A	N/A	6mm by 10 Long Dowel Pin	4**
** Available from an industrial supply company such as MSC (1-800-645-7270).				

Assembly Drawing

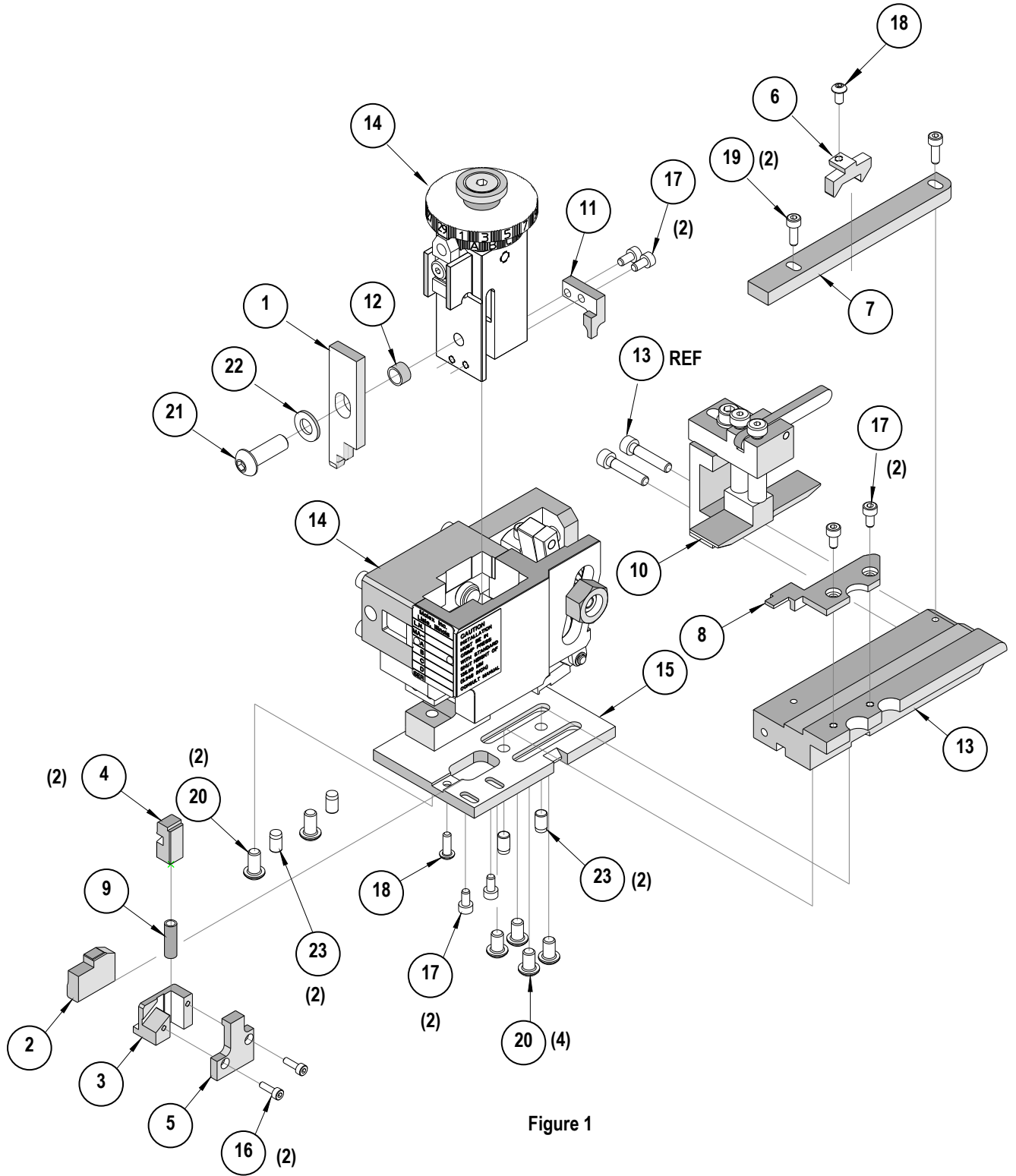

Figure 1

NOTES

1. Molex recommends an extra perishable tooling kit be maintained at your facility.
2. Verify tooling alignment by manually cycling the press and Applicator before crimping under power. Check that all screws are tight.
3. Slugs, Terminals, Dirt and Oil should be kept clear of work area.
4. Wear safety glasses at all times.
5. For recommended maintenance refer to the Mini-Mac Manual.

CAUTION: This applicator should only be used in a press with a shut height of 135.80 mm (5.346"). Tooling damage could result at a lower setting.

CAUTION: To prevent injury never operate this Applicator without the guards supplied with the press or wire-processing machine in place. Reference the press or wire processing manufacturer's instruction manual.

CAUTION: Molex crimp specifications are valid only when used with Molex terminals, applicators and tooling.

Wear Safety Glasses At All Times.

<http://www.molex.com>



Компания «ЭлектроПласт» предлагает заключение долгосрочных отношений при поставках импортных электронных компонентов на взаимовыгодных условиях!

Наши преимущества:

- Оперативные поставки широкого спектра электронных компонентов отечественного и импортного производства напрямую от производителей и с крупнейших мировых складов;
- Поставка более 17-ти миллионов наименований электронных компонентов;
- Поставка сложных, дефицитных, либо снятых с производства позиций;
- Оперативные сроки поставки под заказ (от 5 рабочих дней);
- Экспресс доставка в любую точку России;
- Техническая поддержка проекта, помощь в подборе аналогов, поставка прототипов;
- Система менеджмента качества сертифицирована по Международному стандарту ISO 9001;
- Лицензия ФСБ на осуществление работ с использованием сведений, составляющих государственную тайну;
- Поставка специализированных компонентов (Xilinx, Altera, Analog Devices, Intersil, Interpoint, Microsemi, Aeroflex, Peregrine, Syfer, Eurofarad, Texas Instrument, Miteq, Cobham, E2V, MA-COM, Hittite, Mini-Circuits, General Dynamics и др.);

Помимо этого, одним из направлений компании «ЭлектроПласт» является направление «Источники питания». Мы предлагаем Вам помощь Конструкторского отдела:

- Подбор оптимального решения, техническое обоснование при выборе компонента;
- Подбор аналогов;
- Консультации по применению компонента;
- Поставка образцов и прототипов;
- Техническая поддержка проекта;
- Защита от снятия компонента с производства.



Как с нами связаться

Телефон: 8 (812) 309 58 32 (многоканальный)

Факс: 8 (812) 320-02-42

Электронная почта: org@eplast1.ru

Адрес: 198099, г. Санкт-Петербург, ул. Калинина, дом 2, корпус 4, литера А.