

***GNSS* Module**
SMD type (without Antenna)

GYSFFMAXC

Brief Data Report

GYSFFMAXC

Document constituent list

Control name	Control No.	Document Page
General Items	HD-AG-A121331	1/1
Absolute maximum ratings	HD-AM- A121331	1/1
Electrical characteristics	HD-AE- A121331	1/1
Electrical characteristics	HD-AE- B121331	1/1
Circuit schematic	HD-MC- A121331	1/1
Outline / Appearance	HD-AD- A121331	1/1
Pin Layout	HD-BA-A121331	1/2 - 2/2

Rev. record

07-Aug-2014 Ver.1.0

25-Aug-2014 Ver.1.01

GYSFFMAXC

Control No. HD-AG-A121331	(1/1)	Control name General Items
------------------------------	-------	-------------------------------

(1) Scope

This specification (“Specification”) applies to the hybrid IC “ GYSFFMAXC ”for use

GNSS(GPS+GLONASS) module(“ Product”) manufacture by TAIYO YUDEN Co., Ltd.(“TAIYO YUDEN”)

Please be noted that the product code shall be changed in mass production stage.

1)User’s code : GYSFFMAXC

(Please state this code to order this product.)

2)Function • Features :

- GNSS Module (GPS L1 : 1575.42MHz)
(GLONASS L1: 1598.0625MHz-1605.375MHz)
- 33ch tracking / 99ch acquisition –GPS/GLONASS/QZSS/SBAS
- 12 multi-tone Active Interference Canceller (AIC)
- Support multi-GNSS(GPS/GLONASS), QZSS, SBAS (WAAS / EGNOS / MSAS / GAGAN)
- Additional Features: (to be supported with firmware change)
 - AlwaysLocate™ Advanced location awareness technology
 - EPO™ / HotStill™ orbit prediction
 - EASY™ self-generation orbit prediction
 - Logger function support
- Interface: UART
- Ultra Low Power Consumption
- Embedded High-performance electrical parts:LNA, TCXO, RTC, SAW_FL

3)Application : General Consumer Devices

4)Structure: Hybrid IC loaded with silicon semiconductor

Propriety of Pb free Packaging by customer (thermal resistance) : Available

5)Outline : 10.0mm(typ)×10.8mm(typ)×2.05mm(max) 46 Pin Leadless chip-carrier

6)Marking : Parts Name & Lot Number

7)Packing : Tape & Reel (MP)

GYSFFMAXC

Control No. HD-AM-A121331	(1/1)	Control name Absolute maximum ratings
------------------------------	-------	--

1. Maximum rating

Item	Symbol	MIN	TYP	MAX	Unit	Condition
Input voltage	VDD3V3	-0.3		4.3	V	Ta=25degrees-C
	VDD_BACKUP	-0.3		4.3		
	RESET, GIO/EINT, RX	-0.3		3.6		

GYSFFMAXC

Control No. HD-AE-A121331	(1/1)	Control name Electrical characteristics
------------------------------	-------	--

Electrical characteristics**2.Recommendation operating range**

Item	Symbol	MIN	TYP	MAX	Unit	Condition
Operating input voltage	VDD3V3	3.0	3.3	4.3	V	
	VDD_BACKUP	2.0	3.3	4.3		
Supply voltage ripple and spike noise	VDD3V3			40	mV/p-p	
	VDD_BACKUP			40		
Operating temperature range	Topr	-30	25	85	degrees -C	Humidity =40%RH Note1
Storage temperature range	Tstg	-30	25	85	degrees -C	Humidity =40%RH Note2

Notes:

- Operating temperature range is set to satisfy products electrical characteristics in the short terms. In terms of product life cycle when it is used in condition of varying from TYP standard in the long term, please refer to the reliability condition.
- Storage temperature range is the condition for transportation and storage in temporary.

DC Specifications

The Specification applies for Topr.= 25 degrees-C, voltage=typical

No.	Parameter	Condition	Symbol	Min.	Typ.	Max.	Unit	Remark
1	Input Low Voltage	Rx, GIO/EINT,	VIL18	-0.30	-	0.45	V	IO=1.8V
2	Input High Voltage	RESET	VIH18	1.35	-	2.10	V	IO =1.8V
3	Output Low Voltage	Tx, GIO/EINT	VOL18	-	-	0.27	V	IO=1.8V
4	Output High Voltage		VOH18	1.53	-	-	V	IO =1.8V
5	Input Low Voltage	Force ON	VIL11	-0.30	-	0.27	V	IO=1.8V
6	Input High Voltage		VIH11	0.83	-	2.1	V	IO=1.8V
7	Current MAIN	VDD3V3 Current Consumption (Average)	Icc_Ac	-	22	35	mA	Acquisition
			Icc_Tr	-	18	28	mA	Tracking
8	Current BK	VDD3V3_BACKUP Current Consumption	Icc_bk1	-	6	15	uA	Backup (VDD3V3=0V)
			Icc_bk2	-	24	200	uA	Other mode

Note:

Please note that these electrical characteristics were measured under Taiyo Yuden evaluation environment.

GYSFFMAXC

Control No. HD-AE-B121331	(1/1)	Control name Electrical characteristics
------------------------------	-------	--

RF Specifications

The Specification applies for Topr.=25 degrees-C

No	Parameter	Symbol	Spec			Unit	Remark
			Min	Typ	Max		
1	Frequency	Fc		1575.4		MHz	C/A code
2	Intermediate frequency	IF		13.2		MHz	
3	Image Rejection Ratio	IRR		30		dB	
4	VCO Oscillation Frequency	Fosc		3142.656		MHz	
5	Noise Figure	NF		1.0		dB	
6	Sensitivity 1	Hs1		-162		dBm	Hot start sensitivity
		Ws1		-146			Warm start sensitivity
		Cs1		-146			Cold start sensitivity
		Ts1		-164			Tracking sensitivity
7	TTFF 1	Ht1		1.0		sec	Hot start @-135dBm Note1
		Wt1		31			Warm start@-135dBm Note2
		Ct1		38			Cold start @-135dBm Note3
8	Accuracy 1	Ha1		1.4		m	Hot start @-135dBm
		Wa1		1.4			Warm start@-135dBm
		Ca1		1.4			Cold start @-135dBm

Note1 Hot start : Re-start in state with Data of Almanac, Ephemeris, and time information.

Note2 Warm start : Re-start in state with Data of Almanac.

Note3 Cold start : Start when there is not all information.

Control No. HD-MC-A121331	(1/1)	Control name Circuit Schematic
------------------------------	-------	-----------------------------------

Module Block Diagram

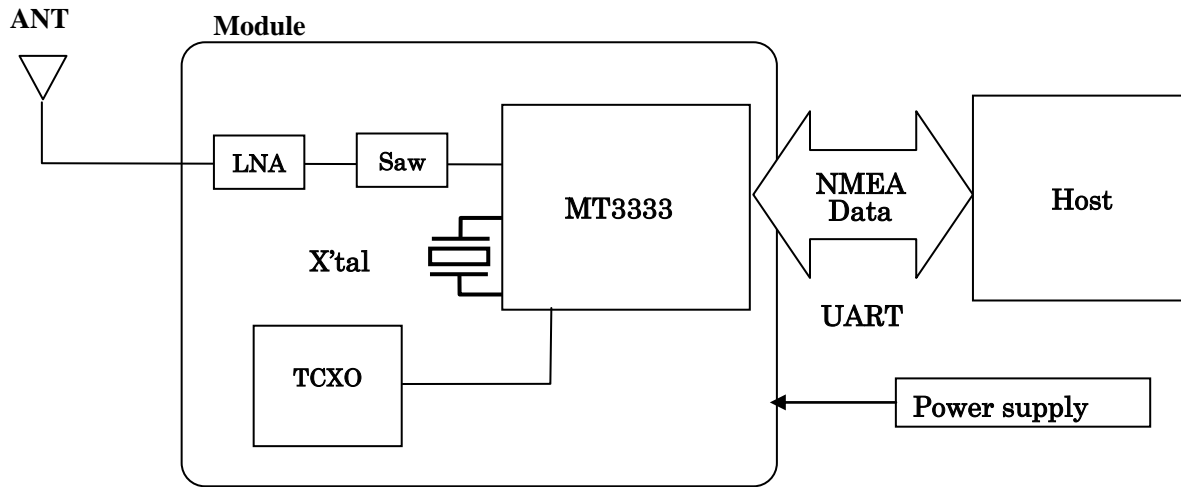

Control No. HD-AD-A121331	(1/1)	Control name Outline/Appearance
------------------------------	-------	------------------------------------

Outline

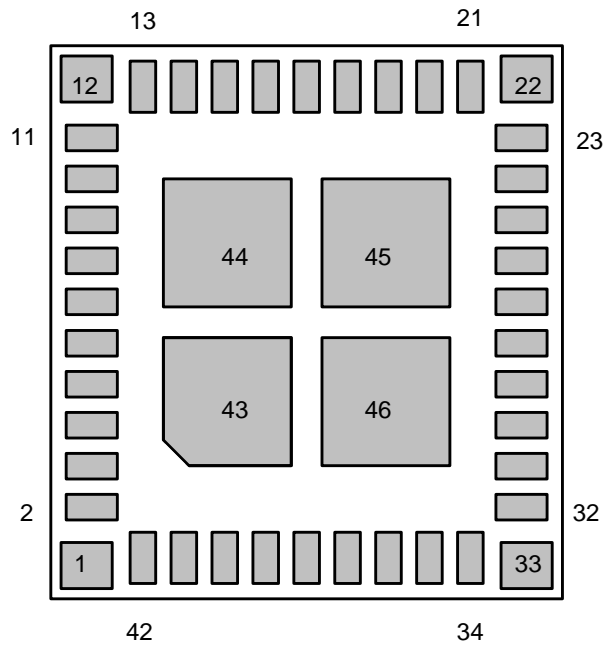
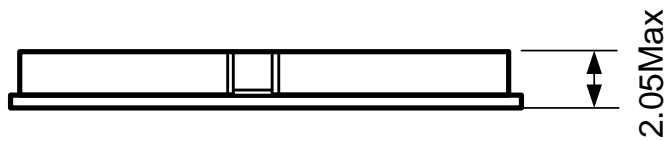
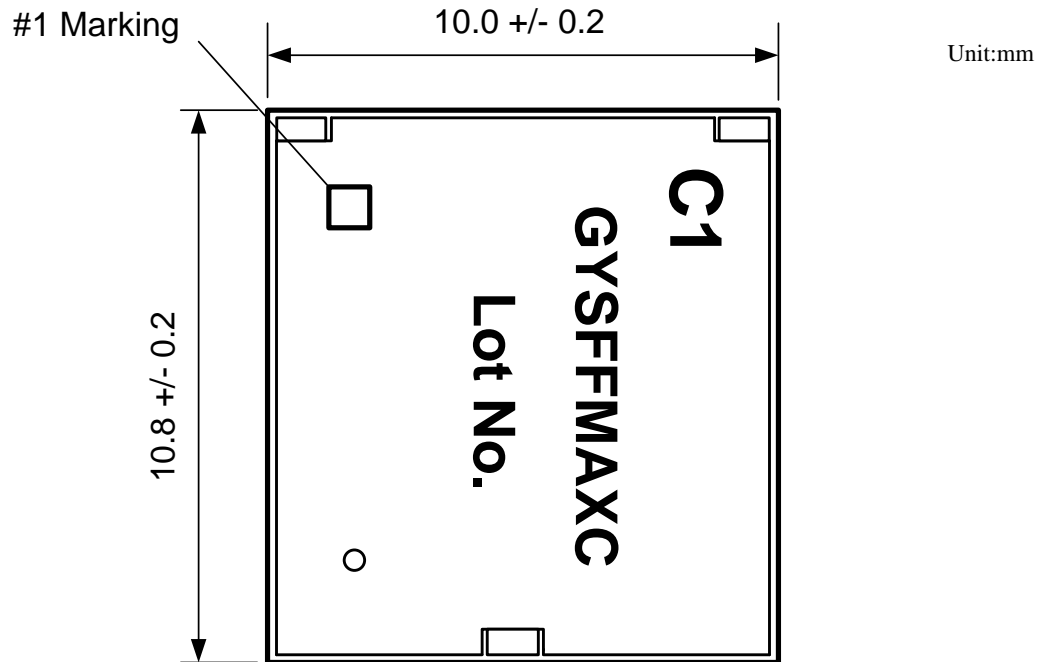

< Bottom View >

GYSFFMAXC

Control No. HD-BA-A121331	(1/2)	Control name Pin Layout
------------------------------	-------	----------------------------

Pin Layout

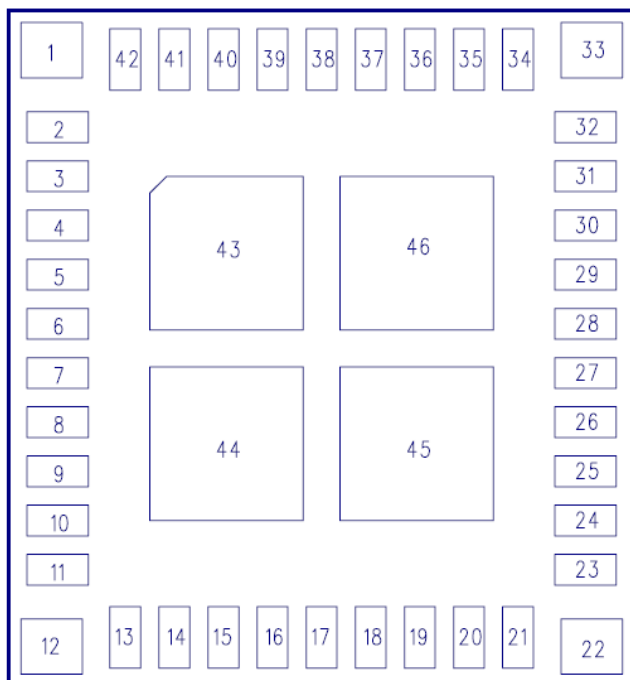

(Top View)

Descriptions

No.	Pin Name	Type	Block	I/O	Description
1	GND	Power	GND	-	GND
2	ANT	RF	RF	I	RF_IN Antenna port
3	GND	Power	GND	-	GND
4	VDD3V3	Power	RF & Digital	I	Power Supply voltage 3.3V Main power supply
5	NC		-	-	Never to connect
6	NC		-	-	Never to connect
7	VDD2V8_OUT	Power	Digital	O	Never to connect
8	GND	Power	GND	-	GND
9	NC		-	-	Never to connect
10	GND	Power	GND	-	GND
11	NC	-	-	-	Never to connect
12	GND	Power	GND	-	GND
13	NC		-	-	Never to connect
14	VDD3V3_BACKUP	Power	Analog	I	Supply Voltage to RTC LDO. Back-up power supply * at all times "ON" by button battery
15	NC		-	-	Never to connect
16	NC	-	-	-	Never to connect
17	32KHZ_OUT	Debug	CLK	O	RTC 32kHz clock output default no output, controlled by S/W build.(Optional) *Never to connect in case of an unnecessary

GY5FFMAXC

Control No. HD-BA-A121331	(2/2)	Control name Pin Layout
------------------------------	-------	----------------------------

No.	Pin Name	Type	Block	I/O	Description
18	NC		-	-	Never to connect.
19	NC		-	-	Never to connect.
20	NC		-	-	Never to connect.
21	GIO_2	CMOS	Digital	I/O	General purpose interface pin. Internal 75kΩpull up *Never to connect in case of an unnecessary.
22	GND	Power	GND	-	GND
23	NC	-	-	-	Never to connect.
24	NC	-	-	-	Never to connect.
25	UART_RXD	CMOS	UART	I	Serial data input for the UART Interface. Internal 75kΩpull up.
26	UART_TXD	CMOS	UART	O	Serial data output for the UART Interface. Internal 75kΩpull up.
27	FORCE_ON	CMOS	Digital	I	In backup mode, logic high to force power on this module.
28	GIO_6	CMOS	Digital	I/O	General purpose interface pin. Internal 75kΩpull down *Never to connect in case of an unnecessary.
29	GIO_7(1PPS)	CMOS	Digital	I/O	1pps signal output (Default: Pulse width:100msec, Output timing: 3DFix)
30	GIO_12 (EINT0)	CMOS	Digital	I/O	External Interrupt, General purpose interface pin Internal 75kΩpull down *Never to connect in case of an unnecessary.
31	GIO_14 (EINT2)	CMOS	Digital	I/O	External Interrupt, General purpose interface pin Internal 75kΩpull up *Never to connect in case of an unnecessary.
32	RESET	CMOS	Digital	I	RESET terminal, active LOW Internal 75kΩpull up
33	GND	Power	GND	-	GND
34	GIO_1	CMOS	Digital	I/O	General purpose interface pin. Internal 75kΩpull up *Never to connect in case of an unnecessary.
35	GIO_0	CMOS	GPIO	I/O	General purpose interface pin. Internal 75kΩpull up *Never to connect in case of an unnecessary.
36	GND	Power	GND	-	GND
37	GND	Power	GND	-	GND
38	GND	Power	GND	-	GND
39	GND	Power	GND	-	GND
40	GND	Power	GND	-	GND
41	GND	Power	GND	-	GND
42	GND	Power	GND	-	GND
43	GND	Power	GND	-	GND
44	GND	Power	GND	-	GND
45	GND	Power	GND	-	GND
46	GND	Power	GND	-	GND



Компания «ЭлектроПласт» предлагает заключение долгосрочных отношений при поставках импортных электронных компонентов на взаимовыгодных условиях!

Наши преимущества:

- Оперативные поставки широкого спектра электронных компонентов отечественного и импортного производства напрямую от производителей и с крупнейших мировых складов;
- Поставка более 17-ти миллионов наименований электронных компонентов;
- Поставка сложных, дефицитных, либо снятых с производства позиций;
- Оперативные сроки поставки под заказ (от 5 рабочих дней);
- Экспресс доставка в любую точку России;
- Техническая поддержка проекта, помощь в подборе аналогов, поставка прототипов;
- Система менеджмента качества сертифицирована по Международному стандарту ISO 9001;
- Лицензия ФСБ на осуществление работ с использованием сведений, составляющих государственную тайну;
- Поставка специализированных компонентов (Xilinx, Altera, Analog Devices, Intersil, Interpoint, Microsemi, Aeroflex, Peregrine, Syfer, Eurofarad, Texas Instrument, Miteq, Cobham, E2V, MA-COM, Hittite, Mini-Circuits, General Dynamics и др.);

Помимо этого, одним из направлений компании «ЭлектроПласт» является направление «Источники питания». Мы предлагаем Вам помощь Конструкторского отдела:

- Подбор оптимального решения, техническое обоснование при выборе компонента;
- Подбор аналогов;
- Консультации по применению компонента;
- Поставка образцов и прототипов;
- Техническая поддержка проекта;
- Защита от снятия компонента с производства.



Как с нами связаться

Телефон: 8 (812) 309 58 32 (многоканальный)

Факс: 8 (812) 320-02-42

Электронная почта: org@eplast1.ru

Адрес: 198099, г. Санкт-Петербург, ул. Калинина, дом 2, корпус 4, литера А.