



CYUSBS236

USB-Serial Development Kit Guide

Doc. # 001-86996 Rev. **

Cypress Semiconductor
198 Champion Court
San Jose, CA 95134-1709
Phone (USA): 800.858.1810
Phone (Intl): +1.408.943.2600
<http://www.cypress.com>



Copyrights

© Cypress Semiconductor Corporation, 2013. The information contained herein is subject to change without notice. Cypress Semiconductor Corporation assumes no responsibility for the use of any circuitry other than circuitry embodied in a Cypress product. Nor does it convey or imply any license under patent or other rights. Cypress products are not warranted nor intended to be used for medical, life support, life saving, critical control or safety applications, unless pursuant to an express written agreement with Cypress. Furthermore, Cypress does not authorize its products for use as critical components in life-support systems where a malfunction or failure may reasonably be expected to result in significant injury to the user. The inclusion of Cypress products in life-support systems application implies that the manufacturer assumes all risk of such use and in doing so indemnifies Cypress against all charges.

Any Source Code (software and/or firmware) is owned by Cypress Semiconductor Corporation (Cypress) and is protected by and subject to worldwide patent protection (United States and foreign), United States copyright laws and international treaty provisions. Cypress hereby grants to licensee a personal, non-exclusive, non-transferable license to copy, use, modify, create derivative works of, and compile the Cypress Source Code and derivative works for the sole purpose of creating custom software and or firmware in support of licensee product to be used only in conjunction with a Cypress integrated circuit as specified in the applicable agreement. Any reproduction, modification, translation, compilation, or representation of this Source Code except as specified above is prohibited without the express written permission of Cypress.

Disclaimer: CYPRESS MAKES NO WARRANTY OF ANY KIND, EXPRESS OR IMPLIED, WITH REGARD TO THIS MATERIAL, INCLUDING, BUT NOT LIMITED TO, THE IMPLIED WARRANTIES OF MERCHANTABILITY AND FITNESS FOR A PARTICULAR PURPOSE. Cypress reserves the right to make changes without further notice to the materials described herein. Cypress does not assume any liability arising out of the application or use of any product or circuit described herein. Cypress does not authorize its products for use as critical components in life-support systems where a malfunction or failure may reasonably be expected to result in significant injury to the user. The inclusion of Cypress' product in a life-support systems application implies that the manufacturer assumes all risk of such use and in doing so indemnifies Cypress against all charges.

Use may be limited by and subject to the applicable Cypress software license agreement.

CapSense[®] is a registered trademark of Cypress Semiconductor Corp. All other trademarks or registered trademarks referenced herein are property of the respective corporations.

Contents



Safety Information	5
1. Introduction	7
1.1 Kit Contents	7
1.2 Getting Started.....	8
1.3 Additional Learning Resources.....	8
1.4 Technical Support.....	8
1.5 Document History	9
1.6 Documentation Conventions	9
1.7 Abbreviations	10
2. Software Installation	11
2.1 CYUSBS236 DVK Software	11
2.2 Install Hardware.....	14
2.3 Uninstall Software.....	14
3. Kit Operation	15
3.1 Default Switch and Jumper Settings.....	16
3.2 USB-Serial Enumeration.....	17
3.3 USB-Serial Configuration on Windows OS.....	19
3.3.1 Connecting CYUSBS236 DVK to Cypress USB-Serial Configuration Utility..	19
3.3.2 USB Configuration	21
3.3.3 UART Configuration	25
3.3.3.1 Test Procedure for CYUSBS236 DVK Configured as UART.....	28
3.3.3.2 Throughput Determination	31
3.3.4 I2C Configuration	33
3.3.4.1 Test Procedure for CYUSBS236 DVK Configured as I2C.....	36
3.3.5 SPI Configuration.....	41
3.3.5.1 Test Procedure for CYUSBS236 DVK Configured as SPI.....	45
3.3.6 CapSense Configuration	50
3.3.6.1 Test Procedure for CYUSBS236 DVK Configured for CapSense ..	54
3.3.7 Battery Charger Detection (BCD) Configuration	58
3.3.7.1 Test Procedure for CYUSBS236 DVK Configured for BCD.....	60
3.3.8 CYUSBS236 DVK Restore Default Configuration Settings.....	62
4. Hardware	65
4.1 Board Details	65
4.2 Theory of Operation.....	66
4.3 Functional Description	67
4.3.1 Features.....	67
4.3.2 Power-Supply System.....	68
4.3.3 LEDs	69

4.3.4	USB Connector	70
4.3.5	Serial Communication Block (SCB)	71
4.3.5.1	SCB0 and SCB1 Jumpers	71
4.3.5.2	RS-232 Interface.....	73
4.3.5.3	I2C Interface	75
4.3.5.4	SPI Interface	76
4.3.5.5	GPIO Header	77
4.3.6	CapSense Buttons	78
4.3.7	Battery Charger Detection.....	78
4.3.8	Reset Switch	79
5.	Additional Information	81
5.1	Using USB-Serial on a Mac OS.....	81
5.1.1	Using CYUSBS236 DVK in Communications Device Class (CDC) Mode	81
5.1.2	Using CYUSBS236 DVK in Vendor Mode.....	82
A.	Appendix	83
A.1	Schematic	83
A.2	CY7C65215 USB-Serial Design Guidelines	88
A.3	Troubleshooting Guide	92
A.4	Bill of Materials (BOM)	94

Safety Information



Regulatory Compliance

The CYUSBS236 USB-Serial kit is intended for use as a development platform for hardware or software in a laboratory environment. The board is an open-system design, which does not include a shielded enclosure. Due to this reason, the board may cause interference to other electrical or electronic devices in close proximity. In a domestic environment, this product may cause radio interference. In such cases, take adequate preventive measures. Also, do not use this board near any medical equipment or RF devices.

Attaching additional wiring to this product or modifying the product operation from the factory default may affect its performance and cause interference with other apparatus in the immediate vicinity. If such interference is detected, suitable mitigating measures must be taken.



The CYUSBS236 kit contains electrostatic discharge (ESD) sensitive devices. Electrostatic charges readily accumulate on the human body and any equipment, and can discharge without detection. Permanent damage may occur on devices subjected to high-energy discharges. Proper ESD precautions are recommended to avoid performance degradation or loss of functionality. Store unused CYUSBS236 boards in the protective shipping package.

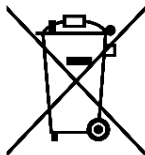

End-of-Life/Product Recycling

This kit has an end-of-life cycle after five years from the year of manufacturing mentioned on the back of the box. Contact your nearest recycler for discarding the kit.

General Safety Instructions

ESD Protection

ESD can damage boards and associated components. Cypress recommends that you perform procedures only at an ESD workstation. If an ESD workstation is not available, use appropriate ESD protection by wearing an antistatic wrist strap attached to the chassis ground (any unpainted metal surface) on the board when handling parts.

Handling Boards

CYUSBS236 boards are sensitive to ESD. Hold the board only by its edges. After removing the board from its box, place it on a grounded, static-free surface. Use a conductive foam pad if available. Do not slide the board over any surface.



CAUTION

- Use only 5 V/2 A power-supply adapter provided with the kit
- Use only the recommended rechargeable Li-ion Battery. Check the polarity of the battery connector before connecting to the board.

1. Introduction



Thank you for your interest in the CYUSBS236 USB-Serial Development Kit (DVK). This DVK is designed as an easy-to-use kit, showcasing the unique features of Cypress's CY7C65215 USB-Serial bridge controller. This device includes CapSense[®], Cypress's leading capacitive touch-sensing technology, and the Battery Charger Detection (BCD) feature, which is compliant with the USB Implementers Forum (USB-IF) Battery Charging Specification. This kit includes four EEPROMs to demonstrate I2C and SPI, two RS-232 line-drivers for UART, two CapSense touch buttons, and a Lithium ion (Li+) battery charger circuit.

CY7C65215 is the first full-speed USB-Serial bridge controller that offers a dual-channel configurable serial interface (UART/I2C/SPI). The controller also features BCD and capacitive touch sensing at low suspend-state currents of 5 μ A. The controller is offered in a 5x5-mm, 32-pin QFN package to meet the dimensional requirements of portable devices.

1.1 Kit Contents

The CYUSBS236 kit contains the following items:

- CYUSBS236 DVK board
- Quick start guide
- USB standard-A to micro-B cable
- Jumper wires
- Extra jumpers
- 5-V power supply adapter
- CY7C65215-32LTXI sample silicon chips

Figure 1-1. Kit Contents



Inspect the contents of the kit; if you find any part missing, contact your nearest Cypress sales office for assistance or go to www.cypress.com/go/support.

1.2 Getting Started

This kit guide helps you get acquainted with the CYUSBS236 DVK. The [Software Installation chapter on page 11](#) provides step-by-step instructions to install the CYUSBS236 DVK software. The [Kit Operation chapter on page 15](#) describes how the kit operates, and explains how to configure the CY7C65215 USB-Serial bridge controller using the Cypress USB-Serial Configuration Utility. The [Hardware chapter on page 65](#) discusses the kit hardware. The [Additional Information chapter on page 81](#) explains how to run the CYUSBS236 kit on the Mac OS. The [Appendix on page 83](#) provides the schematics, layout, bill of materials (BoM), troubleshooting guidelines, and board layout design guidelines for the CY7C65215 USB-Serial bridge controller.

1.3 Additional Learning Resources

Visit the USB-Serial web page, www.cypress.com/go/usbserial for additional learning resources in the form of datasheets and application notes.

1.4 Technical Support

For assistance, go to www.cypress.com/go/support or contact our customer support at +1 (800) 541-4736 Ext. 8 (in the USA) or +1 (408) 943-2600 Ext. 8 (International).

1.5 Document History

Revision	PDF Creation Date	Origin of Change	Description of Change
**	09/24/2013	MVTA	Initial version of kit guide

1.6 Documentation Conventions

Table 1-1. Document Conventions for Guides

Convention	Usage
Courier New	Displays file locations, user entered text, and source code: C:\...cd\icc\
<i>Italics</i>	Displays file names and reference documentation: For example, <i>CYUSBS236 USB DVK.cysusb</i> .
[Bracketed, Bold]	Displays keyboard commands in procedures: [Enter] or [Ctrl] [C]
File > Open	Represents menu paths: File > Open > New Project
Bold	Displays commands, menu paths, and icon names in procedures: Click the File icon and then click Open .
Times New Roman	Displays an equation: $2 + 2 = 4$
Text in gray boxes	Describes cautions or unique functionality of the product.

1.7 Abbreviations

The following table lists the abbreviations used in this kit guide.

Abbreviation	Meaning
BCD	battery charger detection
CDC	communications device class
CDP	charging downstream port
CPHA	clock phase
CPOL	clock polarity
CTS	clear to send
DCD	data carrier detect
DCP	dedicated charging port
DSR	data set ready
DTR	data terminal ready
DVK	development kit
ESD	electrostatic discharge
I2C	Inter Integrated Circuit
LDO	low drop-out
PC	personal computer
PID	product ID
RI	ring indicator
RTS	request to send
SCB	serial communication block
SDP	standard downstream port
SPI	serial peripheral interface
SSN	slave select n
UART	universal asynchronous receiver transmitter
USB	universal serial bus
VID	vendor ID

2. Software Installation



2.1 CYUSBS236 DVK Software

Follow these steps to install the CYUSBS236 DVK software:

1. Download and install the CYUSBS236 DVK software from www.cypress.com/go/CYUSBS236.
The CYUSBS236 DVK software is available in two different installer formats for download:
 - a. **CYUSBS236 Kit ISO:** This file is a complete package, stored in a CD-ROM image format that can be used to create a CD, or extract using ISO extraction programs, such as WinZip or WinRAR. This file includes all the required software, utilities, drivers, hardware files, and user documents.
 - b. **CYUSBS236 Kit Setup:** This installation package contains the files related to the kit. It does not include the Windows installer, Microsoft .NET Framework, and Visual C++ redistributable packages. If these packages are not on your computer, the installer automatically downloads and installs them from the Internet.
2. Run **cyautorun.exe** to start the installation process.
3. Click **Install CYUSBS236 DVK** to start the installation, as shown in [Figure 2-1](#).

Figure 2-1. Kit Installer Startup Screen



4. Select the folder to install the CYUSBS236 DVK-related files. Choose the directory and click **Next**.

Figure 2-2. Default Path for DVK Installation

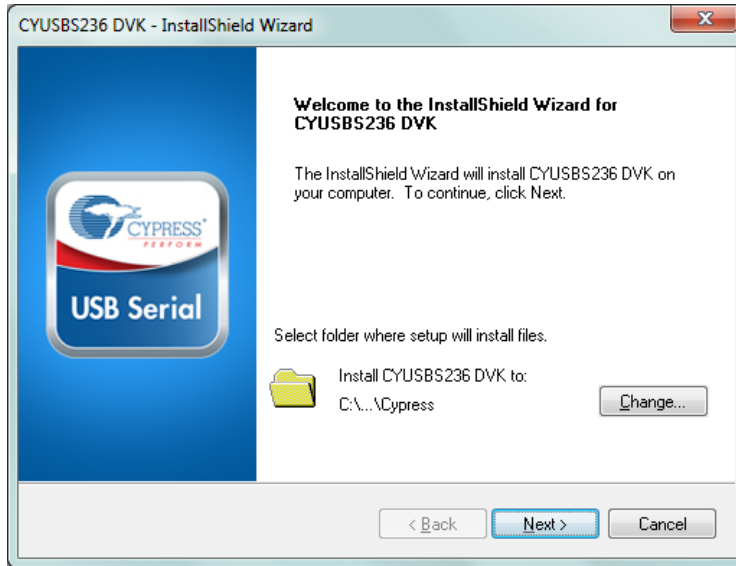

5. The CYUSBS236 Kit ISO installer automatically installs the required software, if it is not present on your computer. The CYUSBS236 Kit Setup installer directs you to download the required software from the Internet.
6. Select the installation type. The drop-down menu has two options: **Typical** (installs all the required features) and **Custom**. Click **Next** after you select the installation type.

Figure 2-3. Installation Type Options

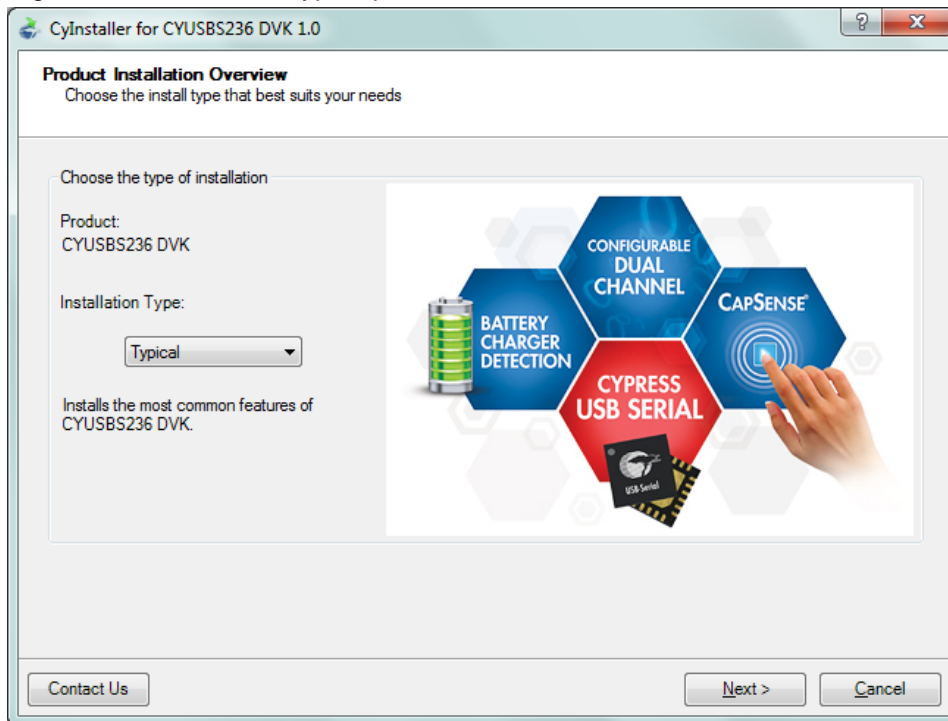

7. Read the Cypress License Agreement and make a selection based on the terms of the license agreement. Click **Next** to continue the installation.

Figure 2-4. Cypress License Agreement

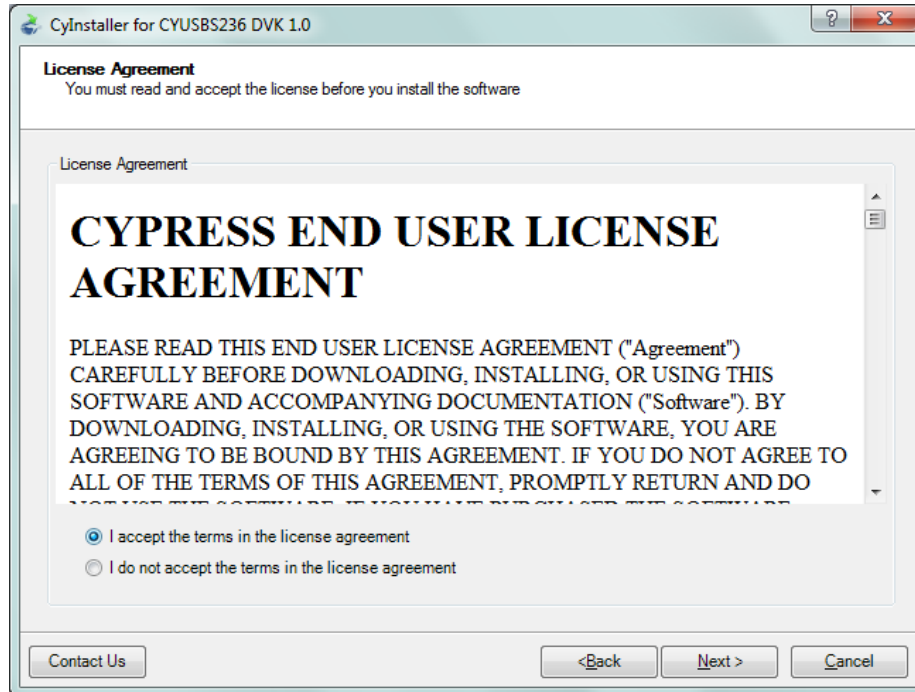

8. When the installation begins, a list of packages appears on the installation page. A green check mark appears adjacent to every package after successful installation. If a message from Windows Security appears, accept the **Always trust software from Cypress Semiconductor** option and click **Install**.

Figure 2-5. Installation Page

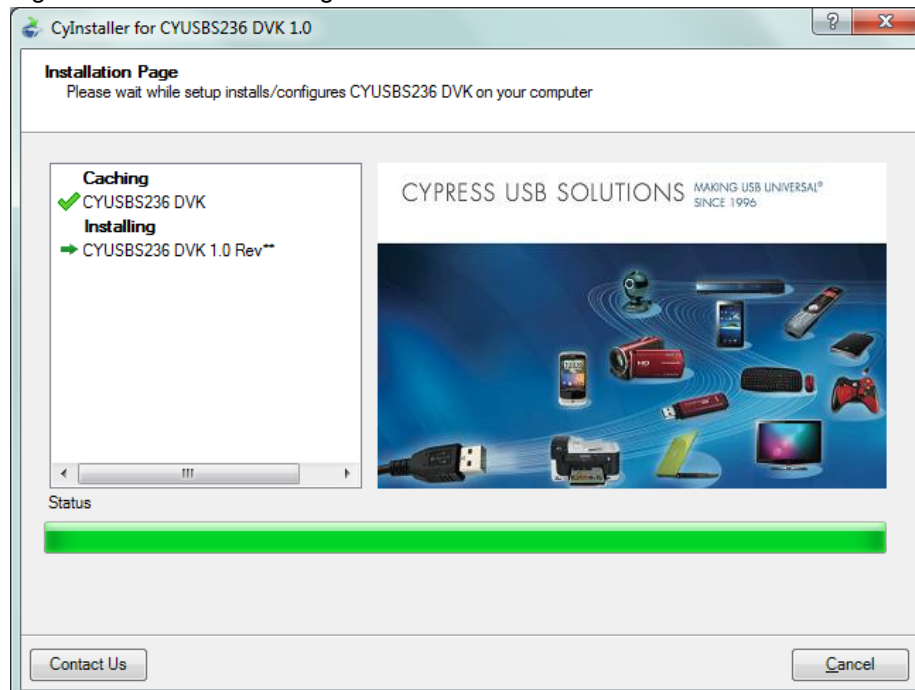

- Enter your contact information or select the **Continue Without Contact Information** check box. Click **Finish** to complete the CYUSBS236 DVK installation.

Figure 2-6. CYUSBS236 DVK Installation Complete

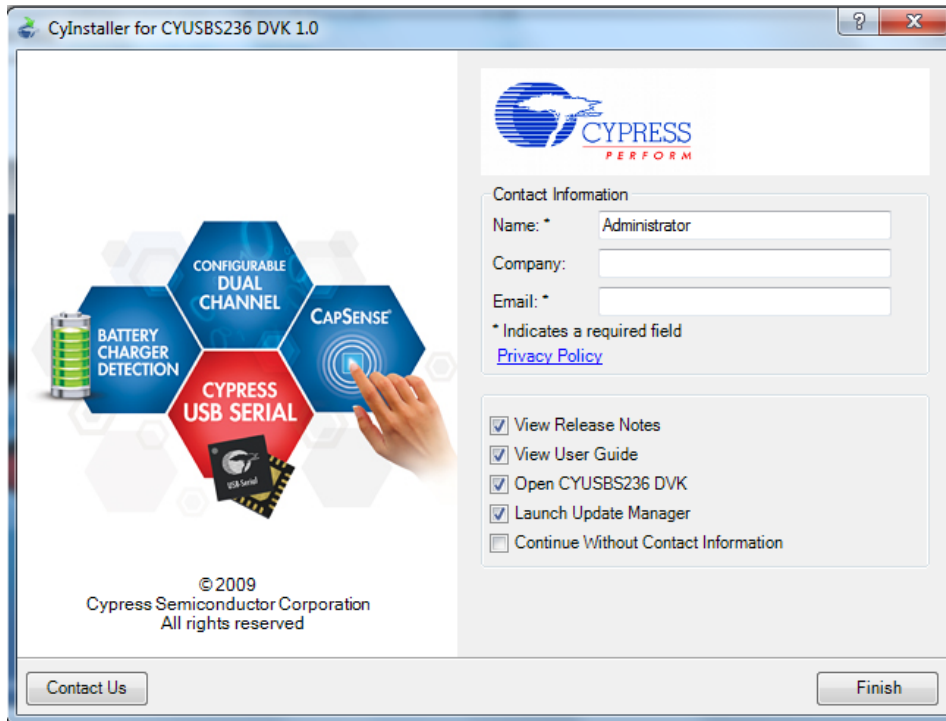

- After the installation is complete, the kit contents are available at the following location:

<Install directory>\Cypress\CYUSBS236 DVK\1.0\

2.2 Install Hardware

This kit does not require any additional hardware installation.

2.3 Uninstall Software

You can uninstall the CYUSBS236 DVK software using one of the following methods:

- Go to **Start > All Programs > Cypress > Cypress Update Manager**; click the **Uninstall** button.
- Go to **Start > Control Panel > Programs and Features**; select the program **CYUSBS236 DVK 1.0 Rev. **** from the list and click the **Uninstall/Change** button.

3. Kit Operation



The CYUSBS236 kit demonstrates the features of the CY7C65215 USB-Serial bridge controller. The CYUSBS236 DVK board is designed to work at 5 V. [Figure 3-1](#) shows an image of the board with references to the onboard components.

Figure 3-1. CYUSBS236 DVK Board

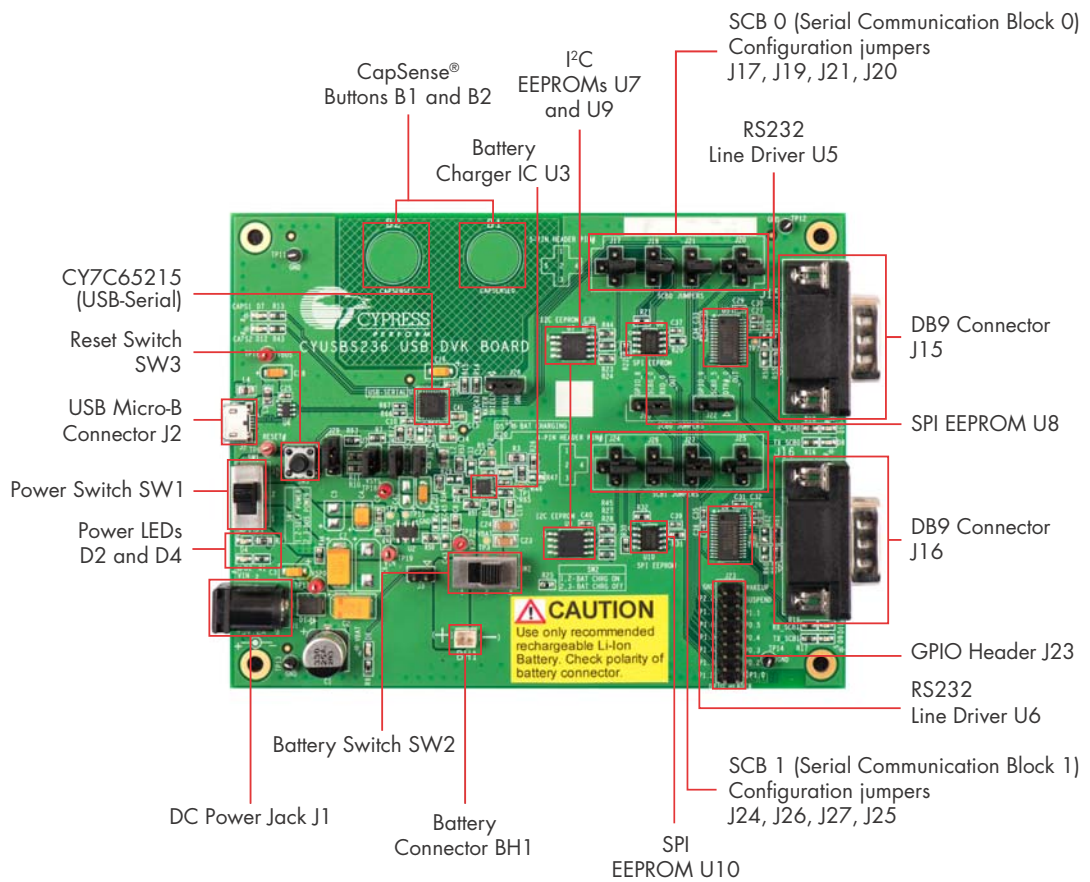

3.1 Default Switch and Jumper Settings

The switches and jumpers on the CYUSBS236 DVK board are shipped with default settings for the USB bus-powered mode, serial interface in the UART mode, CapSense, and BCD enabled. The board is powered by the PC or the hub when it is connected by a USB standard-A to micro-B cable. [Table 3-1](#) provides the default configuration settings for the switches and jumpers.

Figure 3-2. Default Jumper and Switch Settings

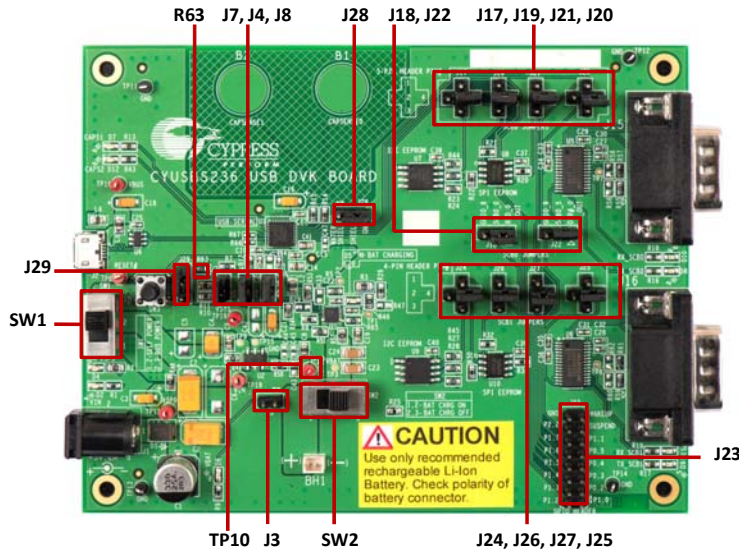

Table 3-1. Default Settings

Jumper	Pins to be Shorted	Function
SW1	Position 2–3	Power supply selection switch set to bus-powered operation
SW2	Position 2–3	Battery power cut-off
J3	Open	VBAT LED
J4	1 and 2	Battery charge enable control pin #0 (BCD0)
J7	1 and 2	Bus detect
J8	1 and 2	Battery charge enable control pin #1 (BCD1)
J17	2 and 4	SCB0 configured as UART
J18	1 and 2	SCB0 configured as UART
J19	2 and 4	SCB0 configured as UART
J20	2 and 4	SCB0 configured as UART
J21	2 and 4	SCB0 configured as UART
J22	1 and 2	SCB0 configured as UART
J23	Open	GPIO header
J24	2 and 4	SCB1 configured as UART
J25	2 and 4	SCB1 configured as UART
J26	2 and 4	SCB1 configured as UART
J27	2 and 4	SCB1 configured as UART
J28	2 and 3	CapSense watershield feature disabled
J29	1 and 2	VBUS detection (The pin near R63 is pin #1 of J29)

3.2 USB-Serial Enumeration

The CYUSBS236 DVK board connects to the PC by a USB standard-A to micro-B cable. The board enumerates as a composite USB device.

Follow these steps for device enumeration:

1. To power up the board:
 - a. **Self-powered mode** - Set SW1 to position 1-2 and connect the 5-V power-supply adapter to J1 on the board.
 - b. **Bus-powered mode** - Set the switch SW1 to position 2-3.
2. Connect the USB standard-A to micro-B cable to the PC and J2 on the board.
3. The PC detects the board and the software driver is automatically bound to the USB device.

Note If the driver installation is unsuccessful, run *setup.exe* from the following folders with administrative privileges:

<Install directory>\Cypress\CYUSBS236 DVK\1.0\driver\cyusb3

<Install directory>\Cypress\CYUSBS236 DVK\1.0\driver\cyusbserial

For more information, refer to the Cypress USB-Serial Driver Installation Guide at the following location: <Install directory>\Cypress\CYUSBS236 DVK\1.0\documentation

Figure 3-3. Install Location of cyusb3 Driver

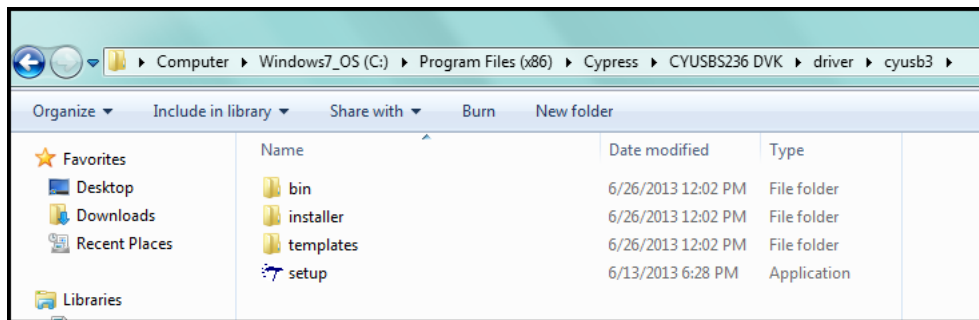
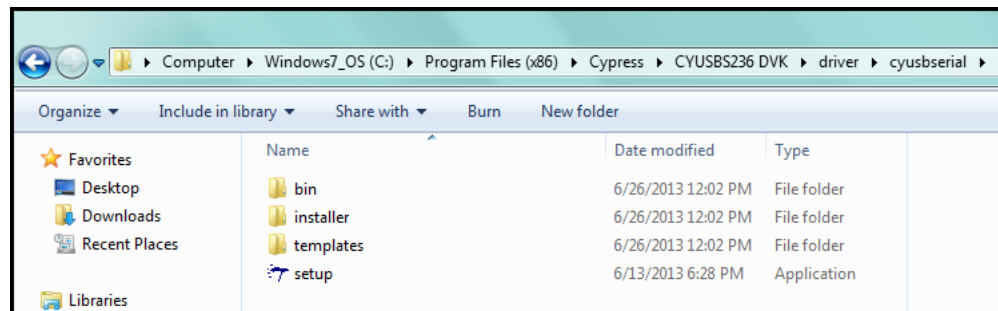

Figure 3-4. Install Location of cyusbserial Driver



Note If a "Welcome to the Found New Hardware Wizard" message appears, select the **Yes, this time only** option and click **Next** to continue the installation.

4. When the software drivers are successfully bound, the board enumeration is complete. The board appears as a composite device in the device manager of the Windows OS (to launch the device manager in Windows 7, go to **Start > Control Panel > Device Manager**), as shown in [Figure 3-5](#).
 - USB-Serial Adapter under CypressUSBConsoleWindowsDriver
 - USB Serial Port (COM#) under Ports (COM & LPT)
 - USB-Serial (Dual Channel) Vendor MFG under Universal Serial Bus controllers

Figure 3-5. CYUSBS236 DVK Enumeration as Dual UART in Device Manager

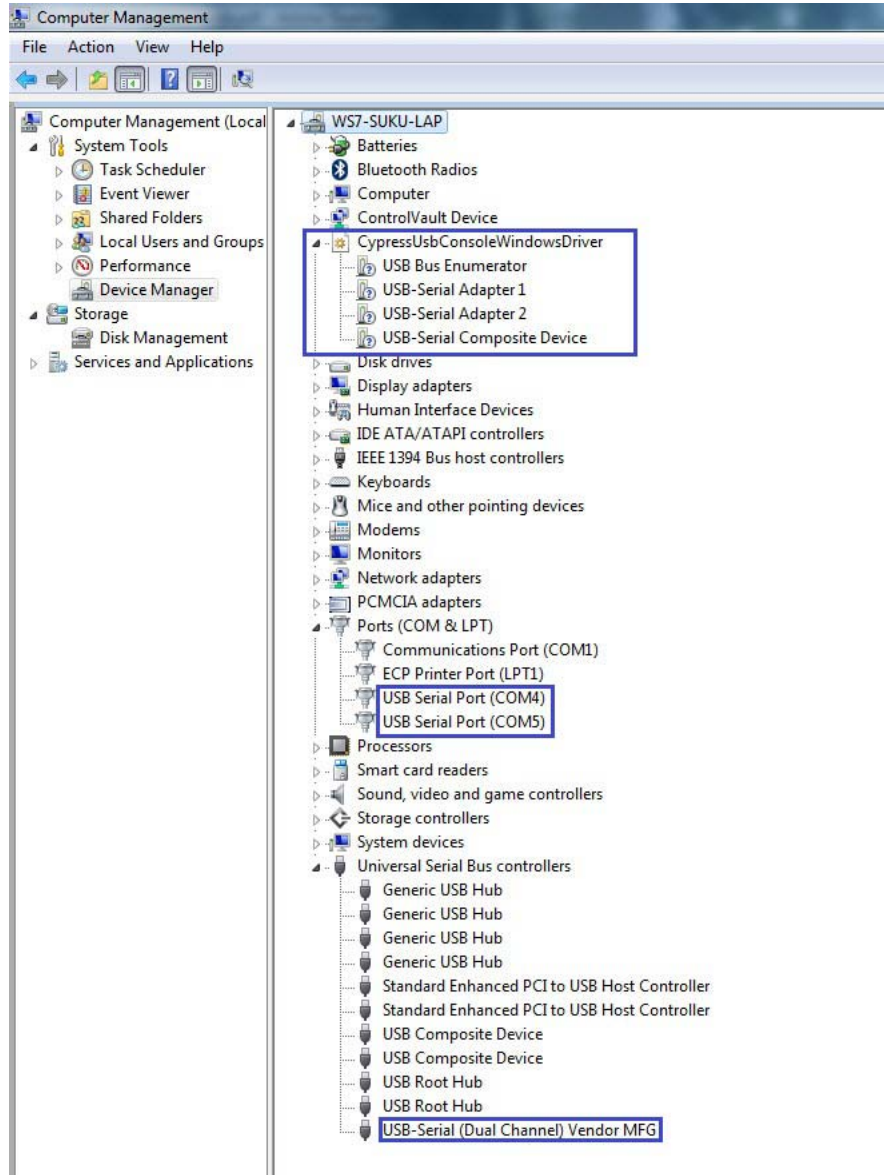

3.3 USB-Serial Configuration on Windows OS

The CY7C65215 USB-Serial bridge controller supports two channel configurable UART/I2C/SPI interfaces. Using the Cypress USB-Serial Configuration Utility, you can configure the onboard CY7C65215 USB-Serial bridge controller as a USB-UART bridge, a USB-I2C bridge, or a USB-SPI bridge. You can also use this utility to configure the CY7C65215 device for CapSense and BCD functionality according to your requirements. The following sections provide detailed descriptions about the device features and configurations.

By default, the CYUSBS236 DVK board is configured for the USB-UART bridge, CapSense, and BCD functionality.

3.3.1 Connecting CYUSBS236 DVK to Cypress USB-Serial Configuration Utility

Follow these steps to connect the device using the Cypress USB-Serial Configuration Utility:

1. Connect the USB standard-A to micro-B cable to your PC and the J2 connector on the board.
2. Set switch SW1 to position 2-3 for bus-powered operation.
3. Run the configuration utility from **Start > All Programs > Cypress > CYUSBS236 DVK > USB Serial Configuration Utility**.

For a detailed description about the configuration utility, refer to the *USB-Serial Configuration Utility User Guide* at the following location:

<Install directory>\Cypress\CYUSBS236 DVK\1.0\documentation

4. The following figure shows the startup screen of the Cypress USB-Serial Configuration Utility.

Figure 3-6. Configuration Utility Startup Screen

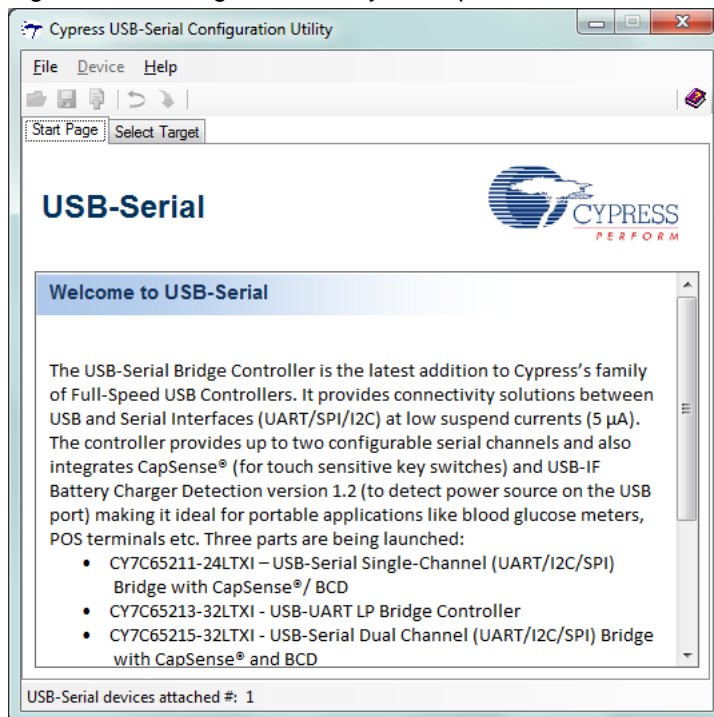

- Click the **Select Target** tab. Select the device from the drop-down menu and click **Connect**.

Figure 3-7. Configuration Utility **Select Target** Tab

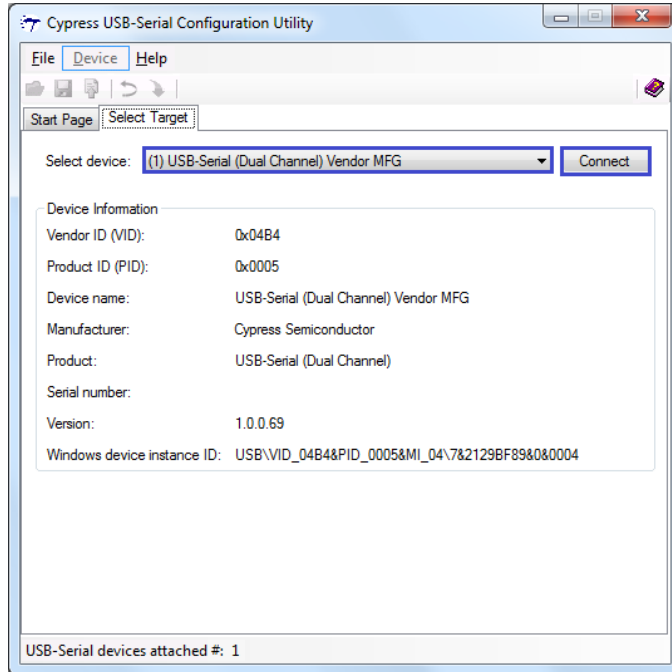

Note The “version” number shown in [Figure 3-7](#) may vary depending upon the latest firmware version on the USB-Serial bridge controller.

- A new tab with the connected device's default settings appears, as shown in [Figure 3-8](#). This tab allows you to modify the device configuration settings, which can be programmed into the device.

Figure 3-8. Configuration Utility **USB** Tab

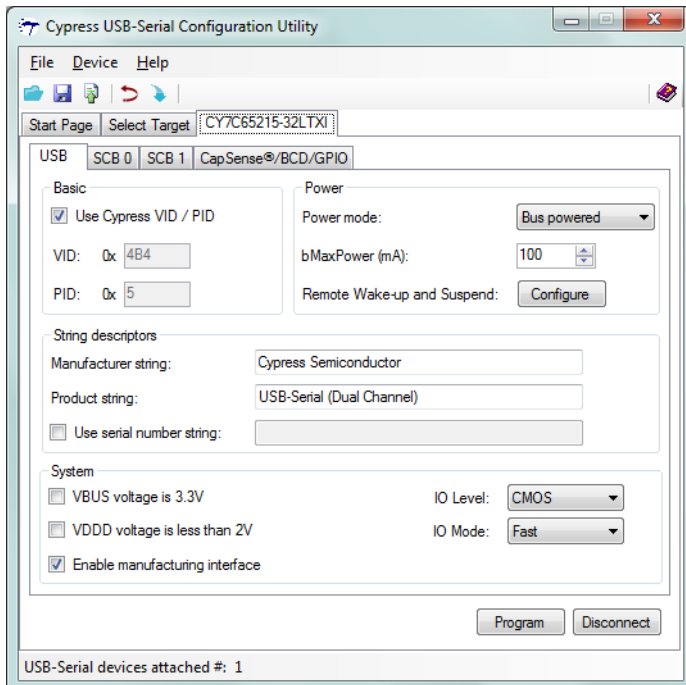

3.3.2 USB Configuration

The USB tab shows the current values of the board's configurable USB and system parameters. Follow these steps to view and modify the parameters for the USB configuration:

1. Follow steps 1 to 6 in the section [Connecting CYUSBS236 DVK to Cypress USB-Serial Configuration Utility on page 19](#) to connect the board to the Cypress USB-Serial Configuration Utility.
2. Click the **USB** tab.

Figure 3-9. Configuration Utility **USB** Tab

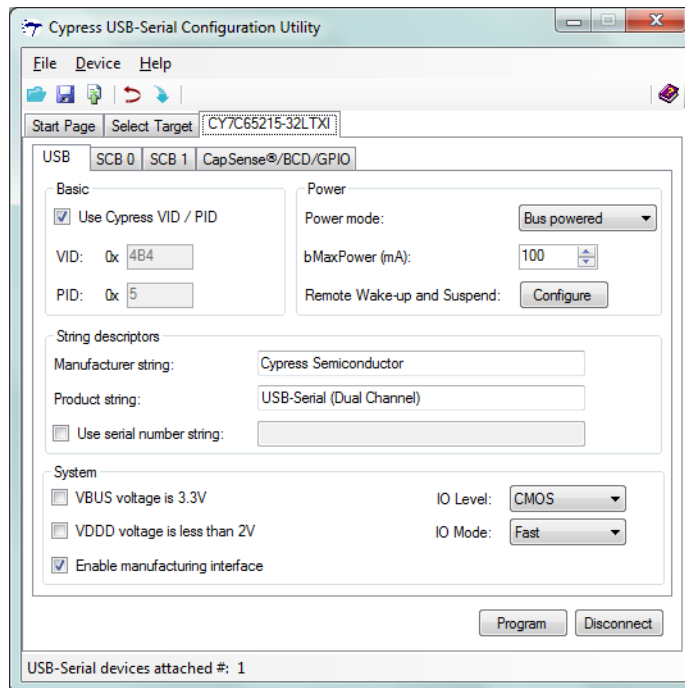

3. You can configure the following USB parameters using the Cypress USB-Serial Configuration Utility:
 - a. Vendor ID (VID)
 - b. Product ID (PID)
 - c. Power Mode (bus-powered or self-powered)
 - d. bMaxPower
 - e. Remote Wake-up and Suspend
 - f. Manufacturer string
 - g. Product string
 - h. Serial number

■ **Vendor ID (VID) and Product ID (PID)**

Default value: 0x04B4 and 0x0005

A 2-byte vendor ID and product ID must be set in hexadecimal format. The VID and PID options cannot be zero or empty. The Cypress VID/PID is programmed by default. To change this, uncheck the **Use Cypress VID/PID** option. Enter the VID and press the **[Tab]** or **[Enter]** key to enable and enter the PID.

■ **Power Mode**

Default value: Bus powered

The USB power mode can be set to either self-powered or bus-powered mode.

■ **bMaxPower**

Default Value: 100 mA

The USB device current requirement value can be set in the range 1 to 500 mA in steps of 2 mA units in bus-powered mode and 0 mA to 500 mA in steps of 2 mA units in self-powered mode.

■ **Remote Wake-up and Suspend**

Default value for Remote wake-up: Enabled

Default value for Suspend: Enabled

Default value for Power Enable: Not enabled (for this board)

Click the **Configure** button (next to **Remote Wake-up and Suspend** in the USB tab) to enable or disable Remote wake-up and Suspend.

Figure 3-10. Remote Wake-up and Suspend Window

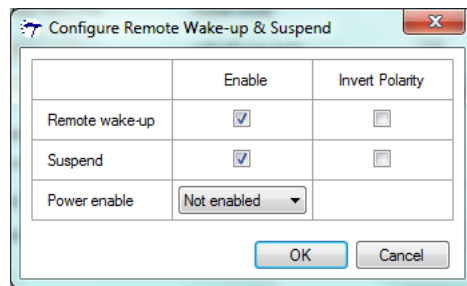

Configurable options:

- Remote wake-up: When enabled, this option can be used to wake up the USB host from suspend state remotely from the attached device. By checking the **Invert Polarity** box, polarity of the wake-up pin can be inverted. On this board, J23.15 (GPIO header) is the wake-up pin. To test the Remote wake-up functionality, follow this procedure:
 - a. Connect the Remote wake-up pin (J23.15) to GND (J23.16) using the provided jumper wire.
 - b. Connect the CYUSBS236 DVK board to a PC using a USB standard A to micro-B cable.
 - c. Set the PC into sleep mode. When the PC enters sleep mode, the USB host on the PC side suspends the connected CYUSBS236 DVK board.
 - d. By default, the Remote wake-up pin is active high. Disconnect the Remote wake-up pin (J23.15) from GND (J23.16) and touch TP10 (V3P3), as shown in [Figure 3-2](#). If the **Invert Polarity** option is selected, then connect the pin to GND to wake up the USB host from the Suspend state.
- Suspend: By checking this box, the Suspend option is enabled. When the USB bus enters the Suspend state, the suspend pin is asserted. By checking the **Invert Polarity** box, polarity of the Suspend pin can be inverted. On this board, J23.13 (GPIO header) is the suspend pin.
- Power enable: The Power enable function is enabled by assigning a GPIO from the drop-down menu. When the USB-UART bridge is configured by the host, this GPIO is asserted. In bus-powered embedded system, to meet the USB 2.0 Specification requirements during Unconfigured and Suspend states, this pin can be used as a notification to control the power to the system. Refer to the *Configuration Utility User Guide* for more details about these options.

Test Procedure for Suspend and Power Enable Pin.

- a. Connect the CYUSBS236 DVK board to a PC using a USB standard A to micro-B cable.
- b. Set the PC into sleep mode.
- c. Check the Suspend pin (J23.13) and Power Enable pin (selected GPIO which comes on external header J23) using a digital multimeter or digital storage oscilloscope. The Suspend pin goes low and Power Enable pin goes high during sleep mode. (By default, the invert polarity is disabled. If the invert polarity is enabled, the Suspend pin goes high during sleep mode.)
- d. Wake up the PC using the Remote wake-up feature described in page 22, or using any other device such as a mouse or keyboard connected to the PC. When the PC becomes active, the Suspend pin goes high and power enable pin goes low.

■ Manufacturer string

Default value: Cypress Semiconductor

The Manufacturer string can be a value of up to 32 characters.

■ Product string

Default value: USB-Serial (Dual Channel)

The Product string can be a value of up to 32 characters.

■ Serial number string

Default value: NULL (No serial number)

Select the check box to enter the serial number, which can be a value of up to 32 characters. If you do not require the serial number, deselect the check box.

System

The Configurable options are:

- a. VBUS voltage is 3.3 V
- b. VDDD voltage is less than 2 V
- c. Enable manufacturing interface
- d. I/O Level
- e. I/O Mode
- f. Program button
- g. Disconnect button

■ VBUS voltage is 3.3 V

Default value: Unchecked

This option must be checked if the VBUS pin is supplied with 3.3 V, and unchecked if the VBUS pin is supplied with 5 V. The board is designed only for 5-V VBUS operation. This option must always be unchecked for the board. The CY7C65215 device supports VBUS voltage range from 3.15 V to 5.25 V.

■ VDDD voltage is less than 2 V

Default value: Unchecked

The board is designed only for 5-V operation. This option must always be unchecked for the board. The CY7C65215 device supports VDDD voltage range from 1.71 V to 5.5 V.

■ Enable manufacturing interface

Default value: Checked

This option enables an additional vendor class manufacturing mode interface for reprogramming the device. For more information, refer to the Enable Manufacturing Interface section in the *Cypress USB-Serial Configuration Utility User Guide*.

- **I/O level**

Default value: CMOS

You can set the device's GPIO logic levels to either CMOS or LVTTTL.

- **I/O Mode**

Default value: Fast

You can set the device's GPIO edge transitions to either fast or slow for EMI considerations. For more information, refer to the GPIO AC Specifications table in the datasheet.

- **Program button**

After configuring all the device settings, the updated configuration settings must be programmed to the device. To program the device, click the **Program** button.

- **Disconnect button**

Click this button to disconnect the DVK from the configuration utility.

4. After configuring the USB and system parameters, click the **Program** button to save the changed USB parameters. On successful programming, the "Program Succeeded" message appears.
4. Click **OK** to continue.
5. Click the **Disconnect** button to disconnect the board from the configuration utility.
6. Press the reset switch **SW3** on the board. The controller is reinitialized with the new parameters and the board re-enumerates, as shown in [Figure 3-5 on page 18](#).

3.3.3 UART Configuration

The CYUSBS236 DVK board is configured for two-channel UART interfaces by default. The board can act as a dual USB-UART bridge to transfer and receive data between the device and the PC via terminal communication software, such as Hyperterminal or Tera Term.

Follow these steps to view and modify the parameters for the UART configuration:

1. Follow steps 1 to 6 of the section [Connecting CYUSBS236 DVK to Cypress USB-Serial Configuration Utility on page 19](#) to connect the board to the Cypress USB-Serial Configuration Utility.
2. Click the **SCB0** tab. Select **UART** as the SCB0 mode from the drop-down menu.

Figure 3-11. Configuration Utility **SCB** Configuration Tab

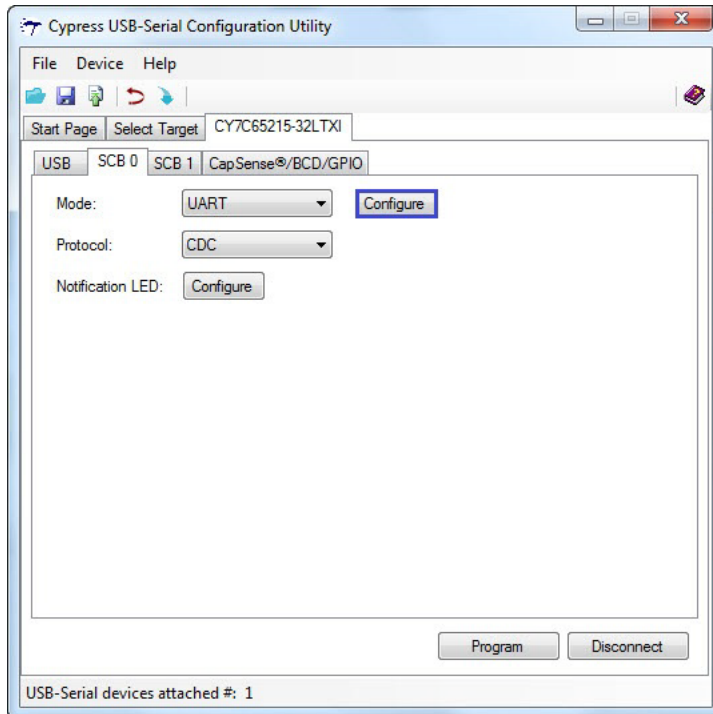

3. Click the **Configure** button, as shown in [Figure 3-11](#), to configure the UART parameters.

Figure 3-12. **UART** Configuration Parameters

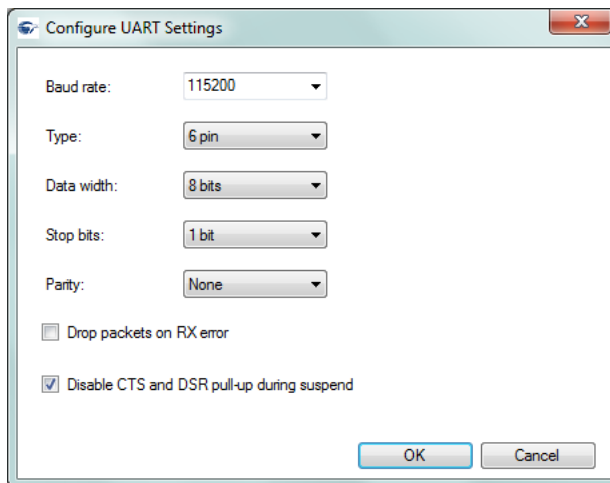

You can configure the following UART parameters by using the Cypress USB-Serial Configuration Utility:

- a. Baud Rate
- b. Type
- c. Data Width
- d. Stop Bits
- e. Parity
- f. Drop packets on RX error
- g. Disable CTS and DSR pull-up during suspend

■ **Baud Rate**

Default value: 115200

You can set the baud rate for the UART in an editable drop-down combo box that lists the pre-defined, standard baud rates. You can also enter a specific baud rate in the combo box. The minimum and maximum baud rates supported by this board are 300 bps and 1 Mbps, respectively. The CY7C65215 device supports 3 Mbps, but the board limits the baud rate to 1 Mbps, due to the limitation of the RS-232 line drivers (U5 and U6).

■ **Type**

Default value: 6 pin for SCB0 and 4 pin for SCB1

You can set the UART type to:

- a. 2 pin (RXD and TXD pins)
- b. 4 pin (RXD, TXD, RTS, and CTS pins)
- c. 6 pin (RXD, TXD, RTS, CTS, DSR, and DTR pins)

■ **Data Width**

Default value: 8 bits

You can set the UART data width to either 7 bits or 8 bits.

■ **Stop Bits**

Default value: 1 bit

You can set the number of UART stop bits to either 1 bit or 2 bits.

■ **Parity**

Default value: None

You can set the parity for the UART data transfer to either None, Odd, Even, Mark, or Space.

■ **Drop packets on RX error**

Default value: Unchecked

This parameter defines the behavior of the UART when an error is detected in the packet received (RX packet/byte). When this option is selected, the data packet/byte in the RX buffer is discarded.

■ **Disable CTS and DSR pull-up during suspend**

Default value: Checked

In an embedded system, this parameter can be checked to reduce system current consumption during Suspend state. This parameter disables CTS and DSR pull-up resistors in Suspend state to meet USB 2.0 Specification current requirements.

4. Click **OK** to close the **Configure UART Settings** window and return to the **SCB0** tab.
5. Select **CDC** as the protocol in the drop-down menu.

6. Notification LEDs are set to None, by default. The notification LED pins are brought out on the external GPIO header J23. You can configure any GPIO as a notification LED by clicking the **Configure** button next to the "Notification LED" in the SCB0 tab and connect an external LED to the assigned GPIO pin on the GPIO header J23.
7. Repeat steps 3 to 5 to configure SCB1 as UART.

Note The **Enable SCB to SCB communication** option is not supported on the board.
8. After configuring the UART interface, click the **Program** button to save the changed SCB0 and SCB1 settings onto the controller. On successful programming, the "Program Succeeded" message appears.
9. Click **OK** to continue.
10. Click the **Disconnect** button to disconnect the board from the configuration utility.
11. Press the reset switch **SW3** on the board. The controller is reinitialized with the new parameters and the board re-enumerates, as shown in [Figure 3-13](#).

Figure 3-13. CYUSBS236 DVK Board Enumeration as USB-UART Controller in Device Manager

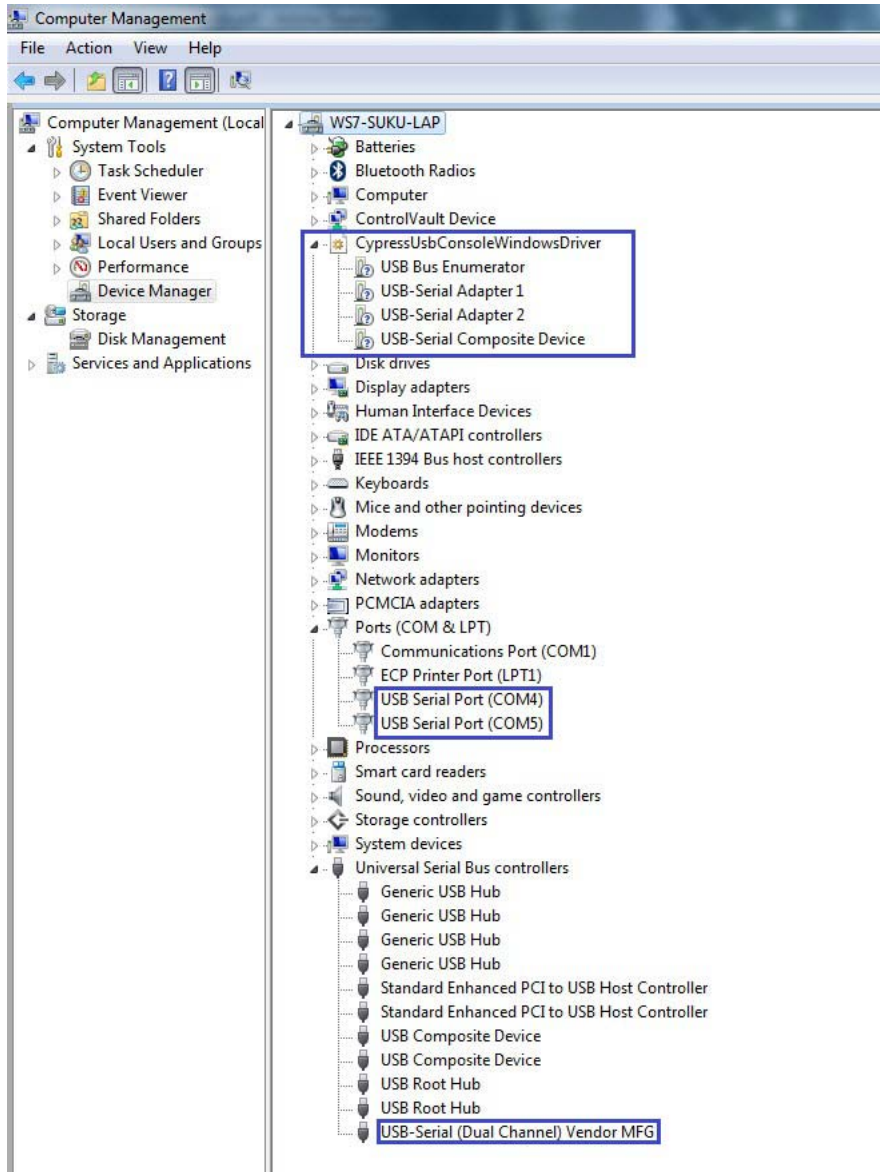

12. The Cypress USB-Serial Configuration Utility is displayed, as shown in [Figure 3-7](#).

3.3.3.1 Test Procedure for CYUSBS236 DVK Configured as UART

1. To test the functionality of the UART interface, set up the jumpers as listed in [Table 3-2](#) and shown in [Figure 3-14](#) and [Figure 3-16](#).

Table 3-2. Jumper Settings

Jumper	Pins to be Shorted	Function
J17	2 and 4	SCB0_2 (Pin #28) configured for UART RTS
J18	1 and 2	SCB0_0 (Pin #2) configured for UART RXD
J19	2 and 4	SCB0_1 (Pin #27) configured for UART DSR
J20	2 and 4	SCB0_3 (Pin #29) configured for UART CTS
J21	2 and 4	SCB0_4 (Pin #30) configured for UART TXD
J22	1 and 2	SCB0_5 (Pin #3) configured for UART DTR
J24	2 and 4	SCB1_0 (Pin #5) configured for UART RXD
J25	2 and 4	SCB1_1 (Pin #6) configured for UART TXD
J26	2 and 4 jumper</td <td>SCB1_2 (Pin #7) configured for UART RTS</td>	SCB1_2 (Pin #7) configured for UART RTS
J27	2 and 4	SCB1_3 (Pin #8) configured for UART CTS
J29	1 and 2	VBUS selection

Figure 3-14. SCB UART Jumpers

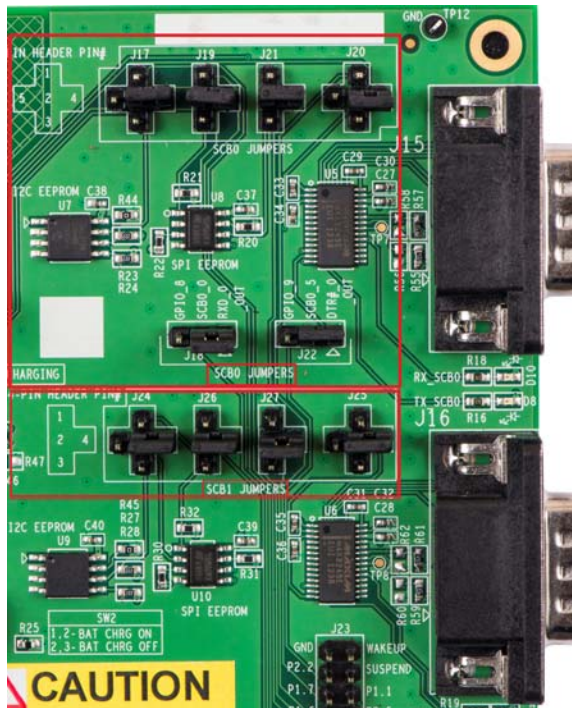
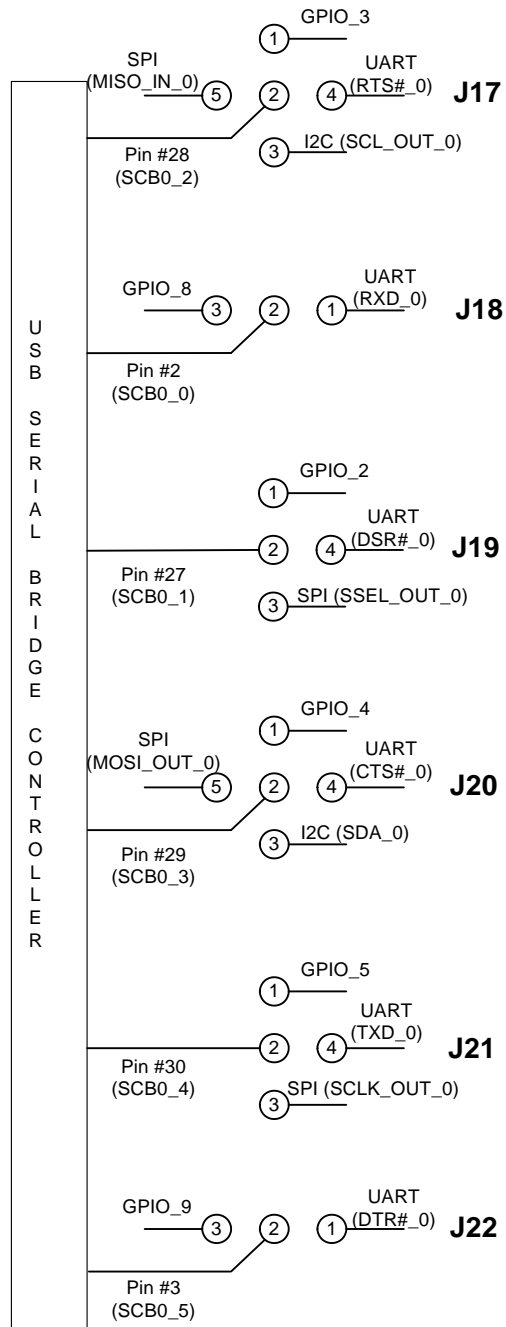

Figure 3-15. SCB0 and SCB1 Jumpers

SCB0 JUMPERS



SCB1 JUMPERS

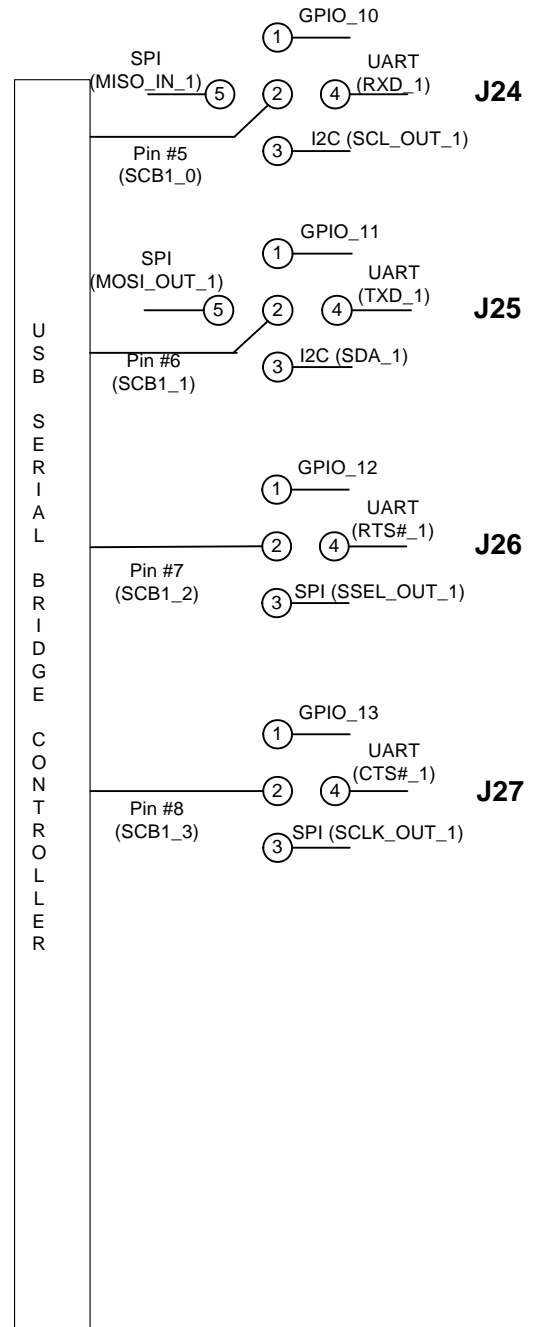
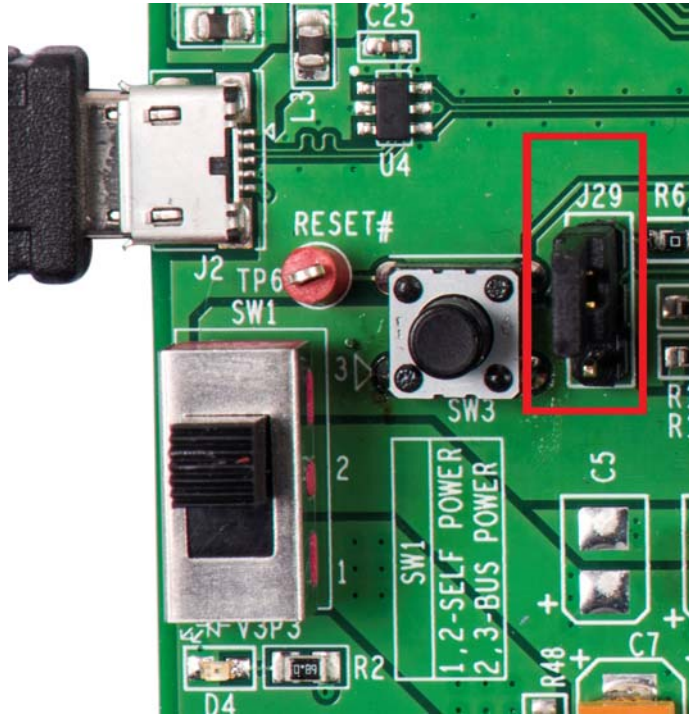
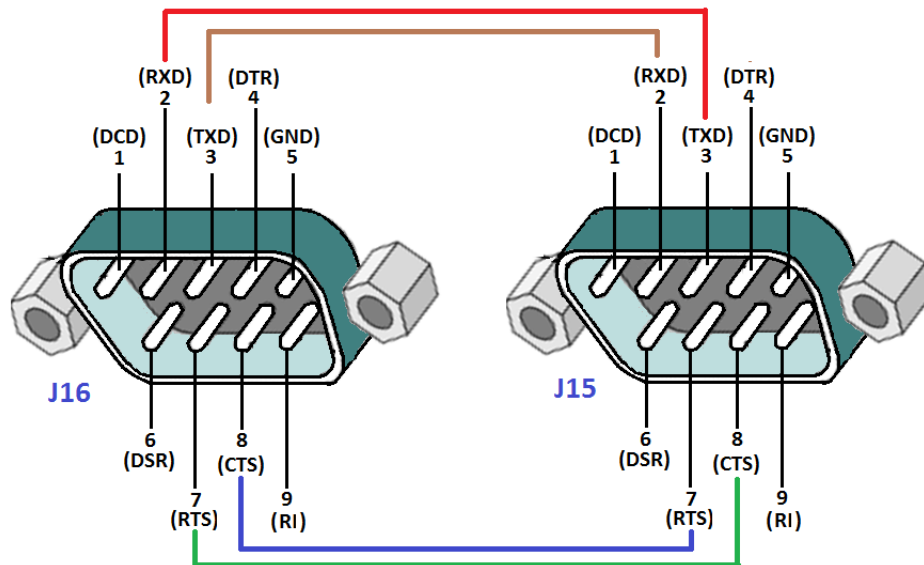

Figure 3-16. VBUS Selection Jumper



2. To check the functionality of the UART, you can perform a quick test by connecting the two DB9 connector pins with the jumper wires as follows:
 - J15.3-J16.2 (TXD of SCB0 to RXD of SCB1)
 - J15.2-J16.3 (RXD of SCB0 to TXD of SCB1)
 - J15.7-J16.8 (RTS of SCB0 to CTS of SCB1)
 - J15.8-J16.7 (CTS of SCB0 to RTS of SCB1)

Figure 3-17. Connection for Back to Back Test



3. Open two instances of the serial emulation terminal, such as Tera Term, which you can install from the following location:
`<Install directory>/Cypress/CYUSBS236 DVK/1.0/teraterm`
4. In the **Tera Term: New Connection** window, click **Serial** and select **USB Serial Port (COM#)** as shown in [Figure 3-18](#). Click **OK**.
Note To change the UART parameters, go to **Setup > Serial Port** in the Tera Term terminal.

Figure 3-18. Tera Term Connection

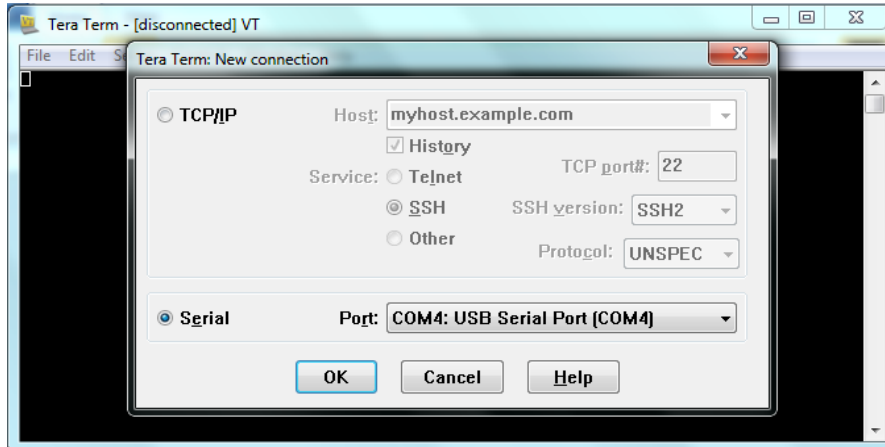

5. Repeat step 4 for the second instance of Tera Term.
6. Type in the text on one terminal, the electrical back-to-back connection (TXD of SCB0 to RXD of SCB1, RXD of SCB0 to TXD of SCB1) enables the data flow from SCB0 to SCB1, which is displayed on another terminal. This test procedure validates the functioning of dual USB-UART bridge. If the local echo option is enabled, then the entered data appears on the same terminal.
Note To enable the local echo option, go to **Setup > Terminal**. In the Tera "Term: Terminal Setup" window, check the **Local echo** box.

Figure 3-19. Tera Term Application: Back-to-Back Test Output

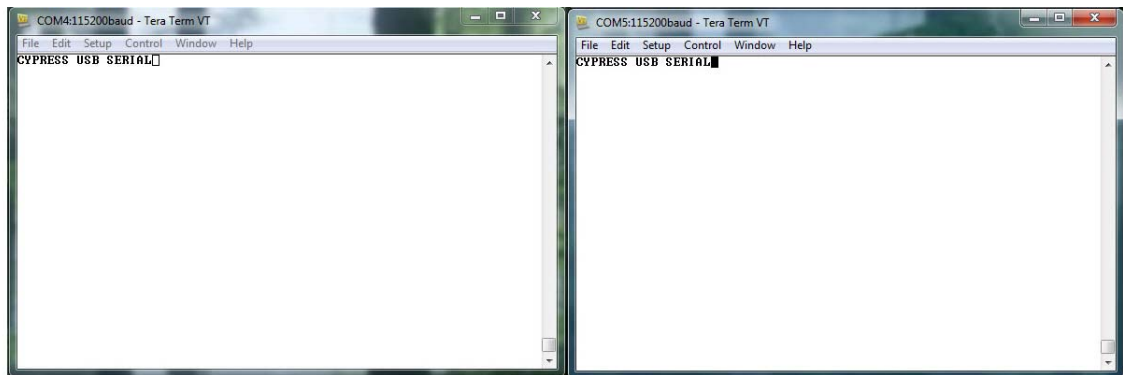

Note These screenshots are captured without enabling Local echo.

3.3.3.2 Throughput Determination

Throughput is the average rate of successful data transfer over the UART channel. It is measured in bits/second. A PC application can be used to determine the throughput of an USB-Serial bridge controller. The CY7C65215 device supports 3 Mbps, but the actual reported throughput on a PC appli-

ation (Tera Term) will be less than 1 Mbps, due to RS-232 line driver limitation, protocol overhead, and PC application latency.

Follow these steps to determine the throughput of the USB-Serial bridge controller:

1. Run two instances of Tera Term.
2. In the first Tera Term window, go to **Setup > Serial Port:**
 - a. Enter '1000000' in the **Baud rate** drop-down combo box.
 - b. Select **Hardware** in the **Flow control** drop-down menu.
 - c. Click **OK**
3. Go to **Setup > Terminal > Receive** and select **CR+LF**. Click **OK** to continue.
4. Repeat steps 2 and 3 for the second Tera Term window.
5. In the second Tera Term window, go to File menu. Select **Send File** from the drop-down menu, as shown in [Figure 3-20](#).

Figure 3-20. Sending the File

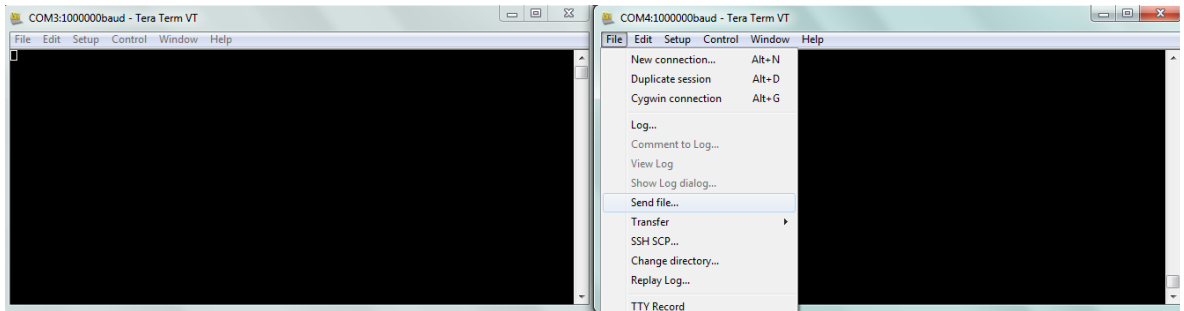

6. Select a file to be sent through **USB Serial Port (COM#)**. After the file is selected, the data transfer starts and the window is displayed, as shown in [Figure 3-21](#).
7. Number of bytes transferred per second determines throughput. The "Tera Term :Send File" window shows effective data throughput in Bytes/sec; multiply this value by 8 to get the throughput in bits/sec.

Figure 3-21. Throughput Determination

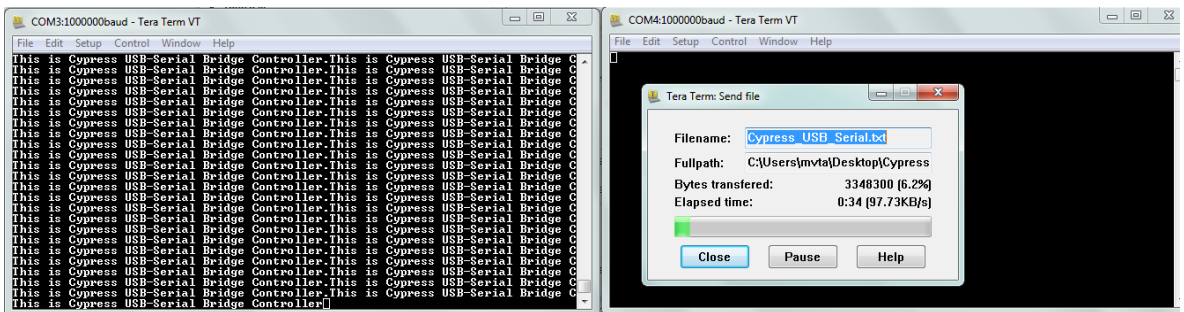

3.3.4 I2C Configuration

You can configure the CYUSBS236 DVK board for two-channel I2C serial interface to function as a dual USB-I2C bridge. The onboard I2C EEPROM (operating in I2C slave mode) can be connected to the USB-Serial bridge controller, CY7C65215, to read and write data. The USB-Serial Test Utility can be used to read, write, and verify the content of EEPROM from the PC. The Test Utility software is available as part of the CYUSBS236 kit installer.

Follow these steps to view and modify the parameters for the I2C configuration:

1. Follow steps 1 to 6 in the section [Connecting CYUSBS236 DVK to Cypress USB-Serial Configuration Utility on page 19](#) to connect the board to the Cypress USB-Serial Configuration Utility.
2. Click the **SCB0** tab. Select **I2C** as the SCB0 mode from the drop-down menu.

Figure 3-22. **SCB0** Configuration Tab

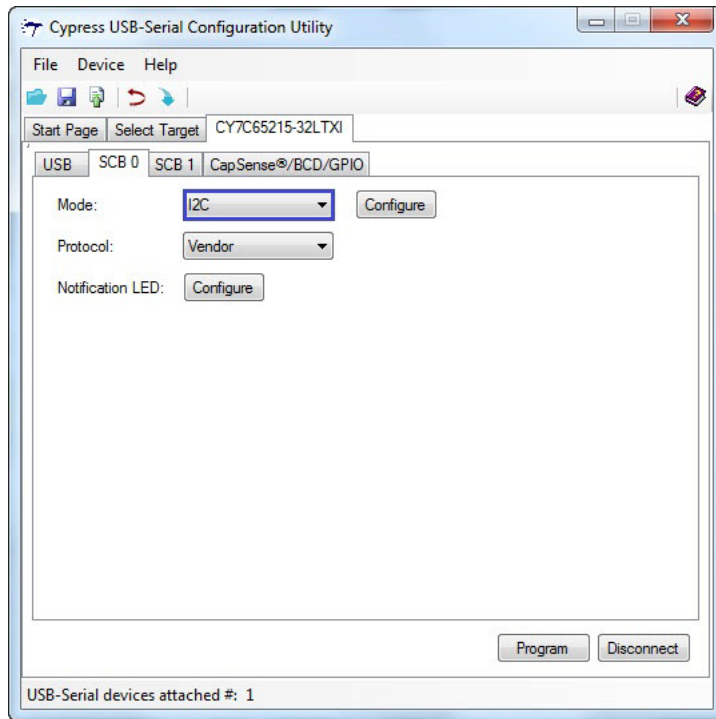

3. Click the **Configure** button, as shown in [Figure 3-22](#), to configure the I2C settings.

Figure 3-23. I2C Configuration Settings

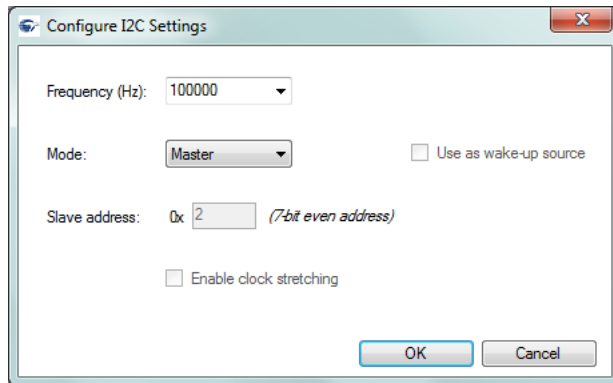

You can configure the following I2C parameters by using the Cypress USB-Serial Configuration Utility:

- a. Frequency
- b. Mode
- c. Use as wake-up source (Slave mode only)
- d. Slave Address (Slave mode only)
- e. Enable clock stretching (Slave mode only)

■ **Frequency**

Default value: 100 kHz

You can set the operating frequency of the I2C master/slave from 1 kHz to 400 kHz in the drop-down menu.

■ **Mode**

Default value: Master

This option is available only in I2C slave mode. USB-Serial bridge controller as I2C slave can be used as remote wake-up source to wake-up the USB host.

You can configure the I2C mode to either a master or a slave. To use the USB-Serial bridge controller as an I2C slave, the I2C pins (SCL and SDA) of SCB0 or SCB1 should be brought out on the external header J23. See [I2C Interface on page 75](#) for the jumper settings to bring out these pins on the external header J23. Connect the I2C master pins (SCL and SDA) to J23.5 (SCL) and J23.7 (SDA) if SCB0 I2C is used. Connect the I2C master pins (SCL and SDA) to J23.2 (SCL) and J23.4 (SDA) if SCB1 I2C is used. Refer to the Cypress USB-Serial API Documentation for more information on establishing communication between I2C master and I2C slave (USB-Serial bridge controller) or contact Cypress [Technical Support](#).

■ **Slave Address**

Default value: 2

This option is available only in the I2C slave mode. The I2C slave address can be from 2 to 126 (in decimal) in increments of 2.

■ **Enable clock stretching**

Default value: Unchecked

This option is available only in I2C slave mode.

You can use this option when there is a mismatch between the master and the slave clock frequency. Both master and slave can operate at the same frequency by enabling clock stretching.

■ **Use as wake-up source**

Default value: Disabled

This option is available only in I2C slave mode. USB-Serial bridge controller as I2C slave can be used as remote wake-up source to wake-up the USB host.

4. Click **OK** to close the **Configure I2C Settings** window and return to the **SCB0** tab.
5. Select **Vendor** as the protocol in the drop-down menu.
6. Notification LEDs are set to None, by default for this board. The notification LED pins are brought out on the external GPIO header J23. You can configure any GPIO as a notification LED by clicking the **Configure** button next to "Notification LED" in the SCB tab and connect an external LED to the assigned GPIO pin on the GPIO header J23.
7. Repeat steps 3 to 5 to configure SCB1 as I2C.

Note The **Enable SCB to SCB communication** option is not supported on the board.

8. After configuring the I2C interface, click the **Program** button to save the changed SCB0 and SCB1 settings. On successful programming, the "Program Succeeded" message appears.
9. Click **OK** to continue.
10. Click the **Disconnect** button to disconnect the board from the configuration utility.
11. Press the reset switch **SW3** on the board. The controller is reinitialized with the new parameters and the board re-enumerates, as shown in [Figure 3-24](#).

Figure 3-24. CYUSBS236 DVK Enumeration as USB-Serial Bridge Controller in Device Manager

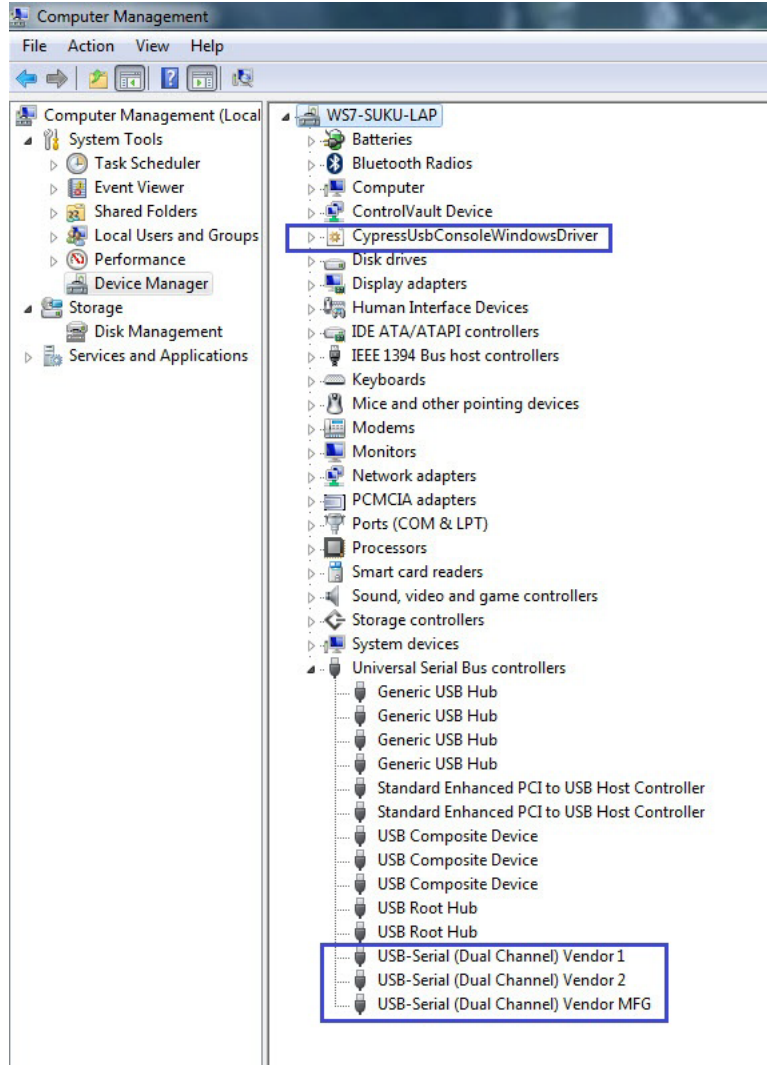

12. The Cypress USB-Serial Configuration Utility is displayed, as shown in [Figure 3-7](#).

3.3.4.1 Test Procedure for CYUSBS236 DVK Configured as I2C

1. To test the functionality of the I2C interface, set up the jumpers as listed in [Table 3-3](#) and shown in [Figure 3-25](#) and [Figure 3-26](#).

Table 3-3. Jumper Settings

Jumper	Pins to be Shorted	Function
J17	2 and 3	SCB0_2 (Pin #28) configured for I2C SCL
J20	2 and 3	SCB0_3 (Pin #29) configured for I2C SDA
J24	2 and 3	SCB1_0 (Pin #5) configured for I2C SCL
J25	2 and 3	SCB1_1 (Pin #6) configured for I2C SDA
J29	1 and 2	VBUS selection

Figure 3-25. SCB I2C Jumpers

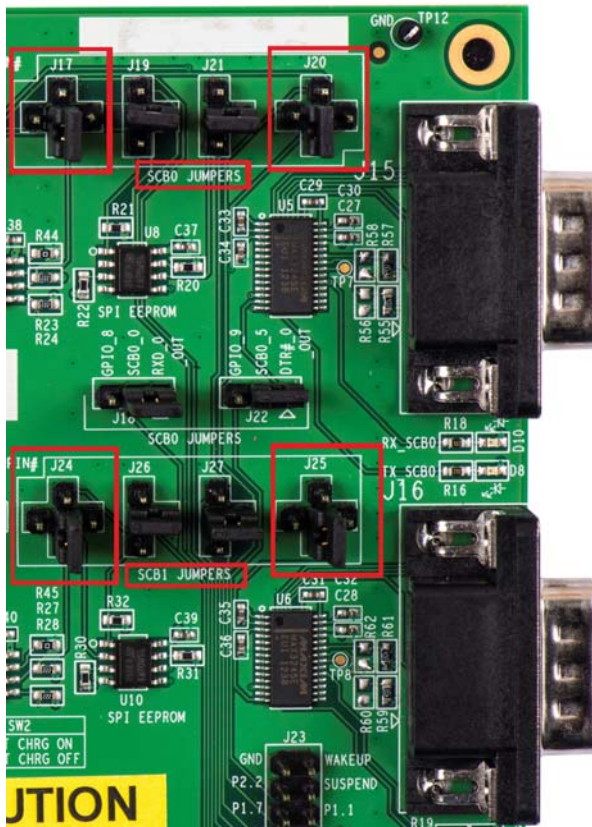
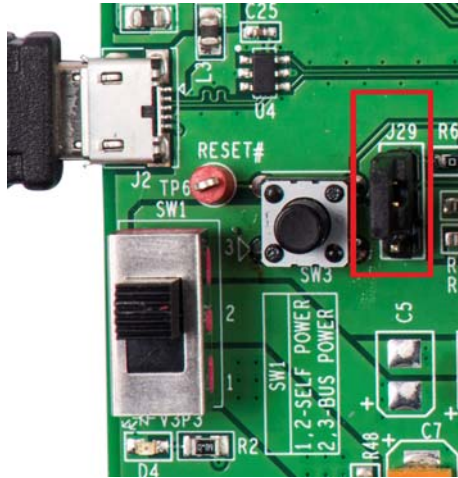
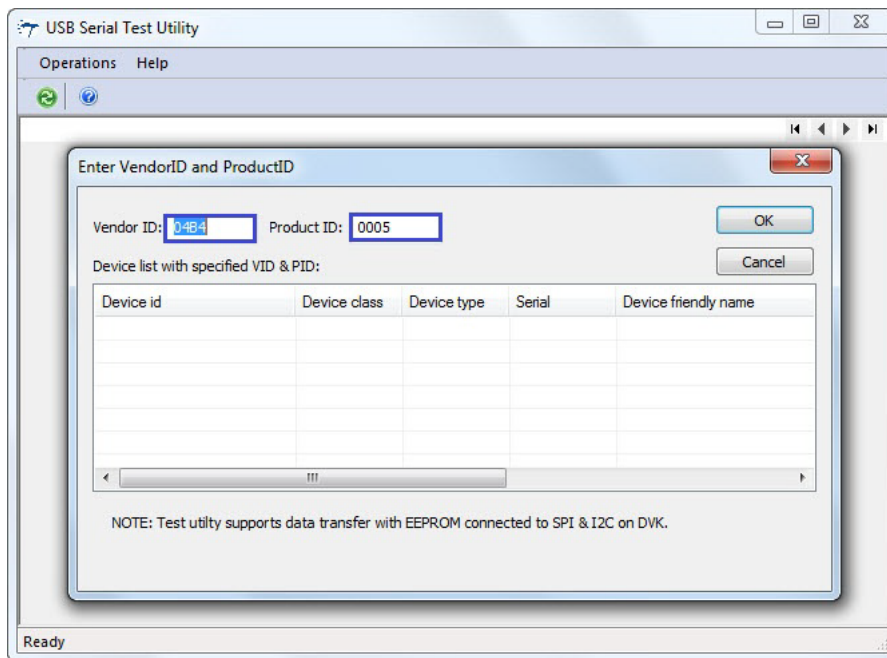

Figure 3-26. VBUS Selection



2. Run the USBSerialTestUtility from **Start > All Programs > Cypress > CYUSBS236 DVK > USBSerialTestUtility**.
3. To use the default Cypress PID, change the Product ID in the text box to **000A**.
Note The user has the option to enter custom Vendor ID and Product ID.

Figure 3-27. Test Utility (VID and PID Selection)



4. The test utility lists the interfaces available on the board for the I2C interface. Click **OK**.

Figure 3-28. Test Utility (change of PID)

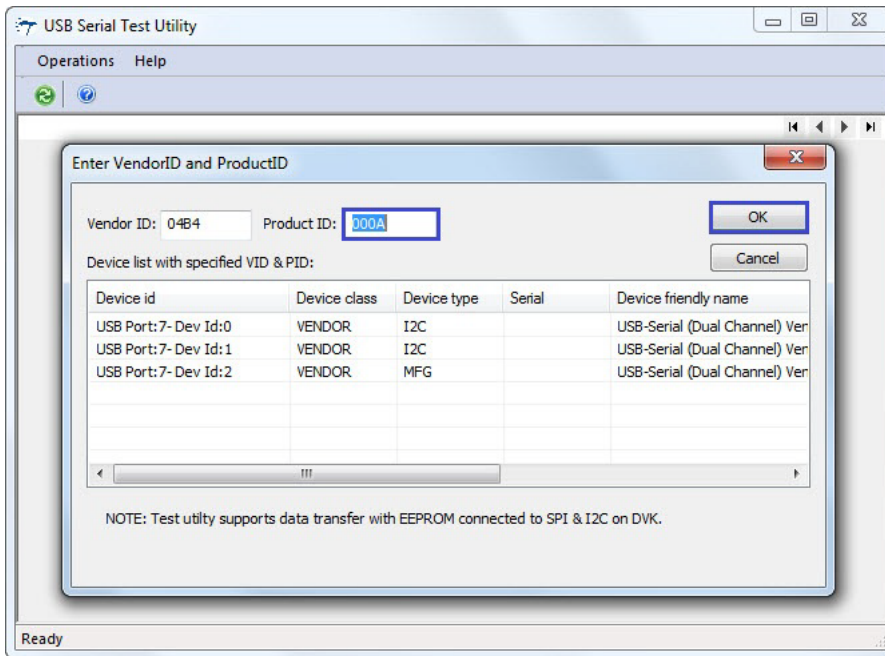

5. The I2C[USB Port:7 - Dev Id:0] tab, which is used to test SCB0 I2C operation is displayed, as shown in Figure 3-29.
6. Enter an EEPROM page address within the range (0x0–0xFF) specified in the text box and click **Write data**. The status bar at the bottom of window displays the status of the data.

Figure 3-29. Test Utility Data Transfer

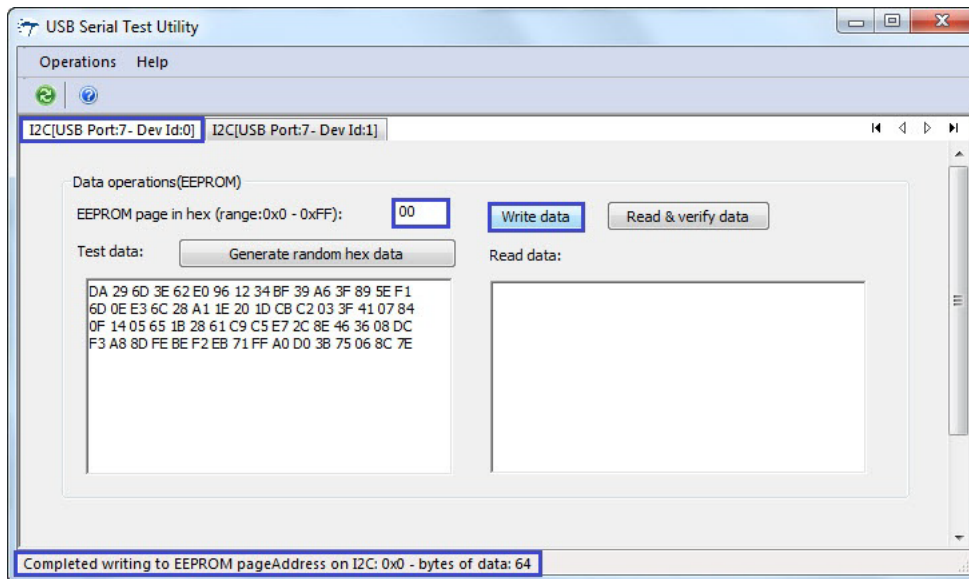

7. Click **Read & verify data**. When the written and read back data are the same, the "Data verification successful" message appears.

Figure 3-30. Test Utility Data Transfer Verification

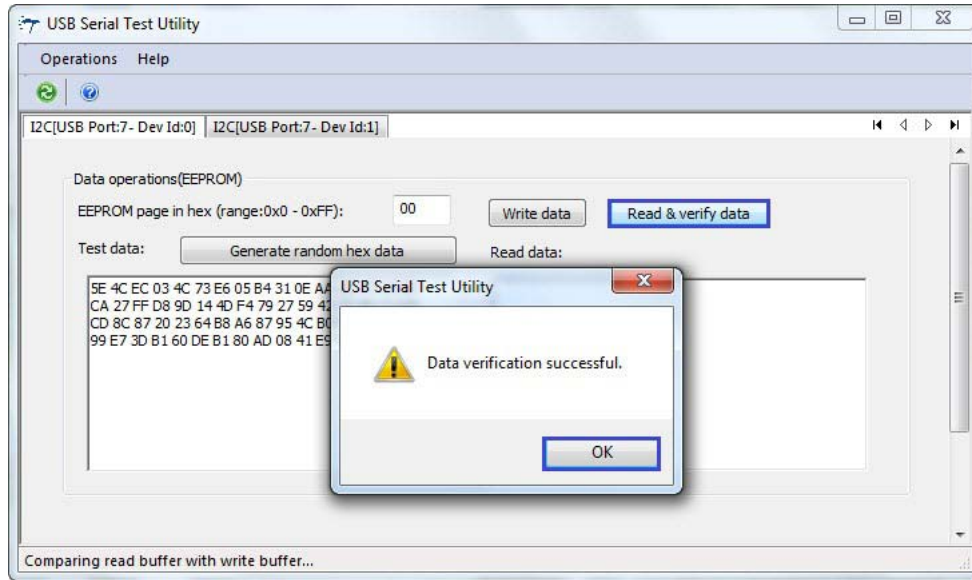

8. Click **OK**. The "Data verification successful" message appears at the bottom of the window.

Figure 3-31. Test Utility Successful Data Transfer Verification

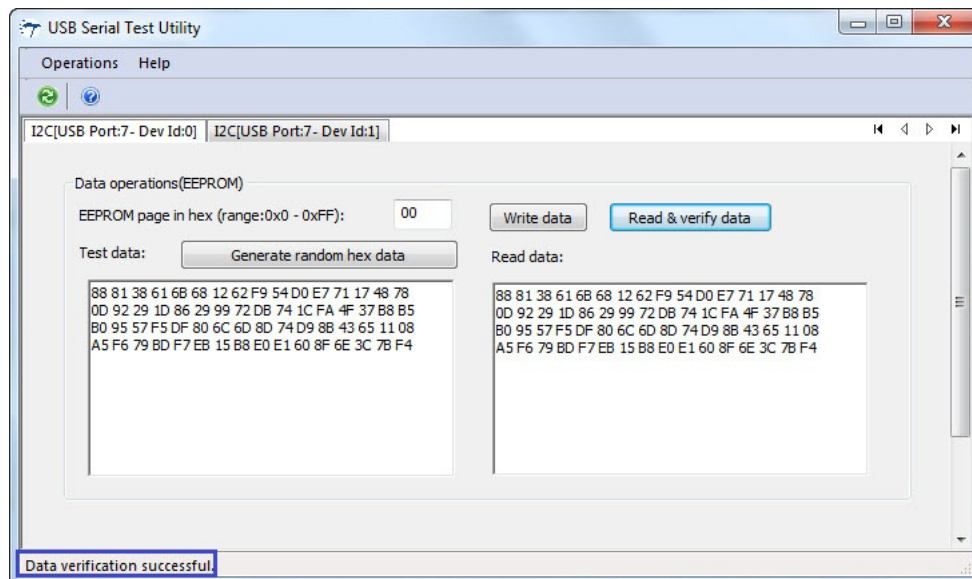

9. To test SCB1 I2C operation, click the **I2C[USB Port:7 - Dev Id:1]** tab, as shown in [Figure 3-32](#). Follow steps 6 to 8 to verify the operation.

Figure 3-32. Test Utility SCB1 I2C Tab

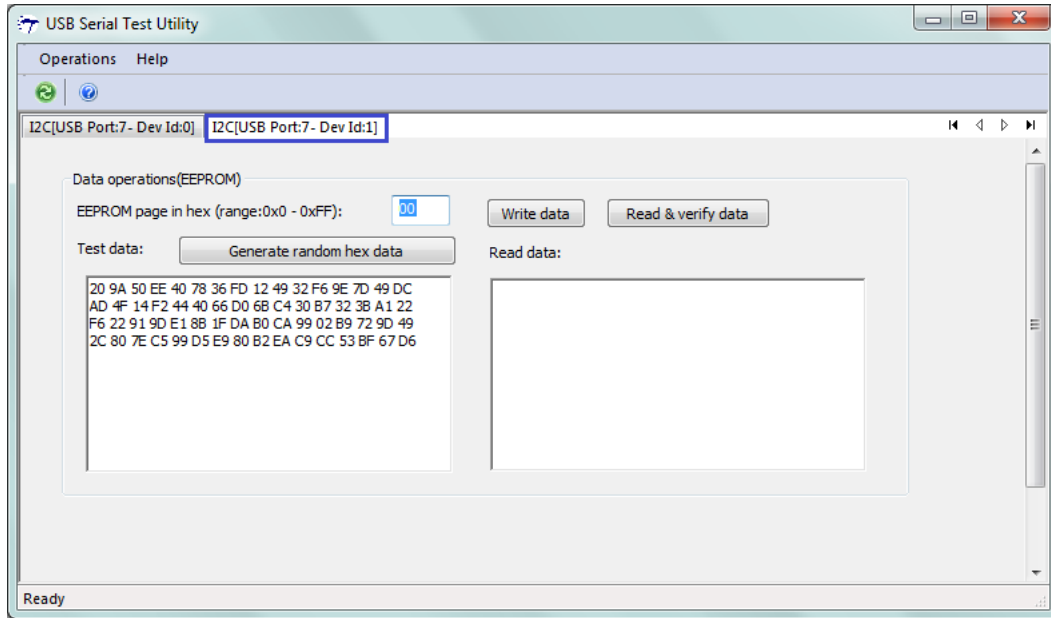

3.3.5 SPI Configuration

You can configure the CYUSBS236 DVK board for the two-channel SPI serial interface to function as a dual USB-SPI bridge. The onboard SPI EEPROM (operating in the SPI slave mode) can be connected to the CY7C65215 USB-Serial bridge controller, to read and write data. The USB-Serial Test Utility provided can be used to read, write, and verify data from the PC. The Test Utility software is available as part of the CYUSBS236 kit installer.

Follow these steps to view and modify the parameters for the SPI configuration:

1. Follow steps 1 to 6 in the section [Connecting CYUSBS236 DVK to Cypress USB-Serial Configuration Utility on page 19](#) to connect the board to the Cypress USB-Serial Configuration Utility.
2. Click the **SCB0** tab. Select **SPI** as the SCB0 mode from the drop-down menu.

Figure 3-33. Configuration Utility SCB0 Configuration Tab

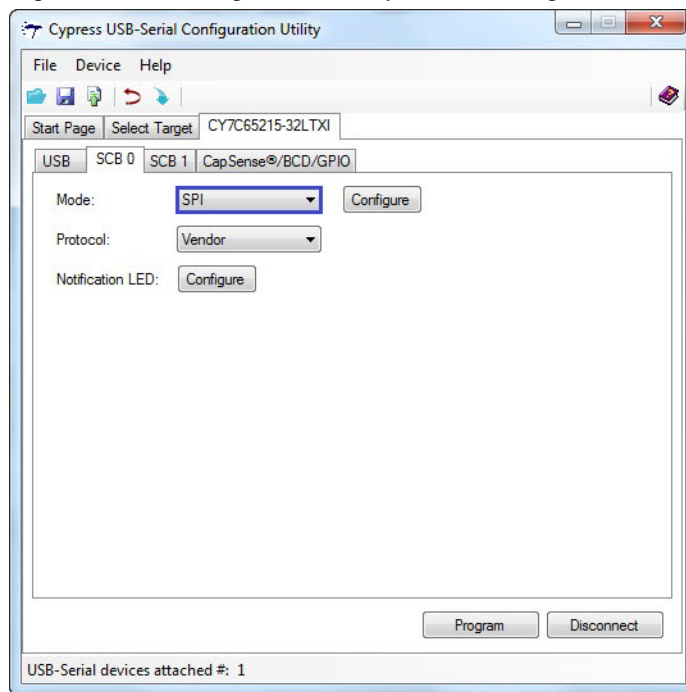

- Click the **Configure** button, as shown in [Figure 3-33](#), to configure the SPI settings.

Figure 3-34. SPI Configuration Settings

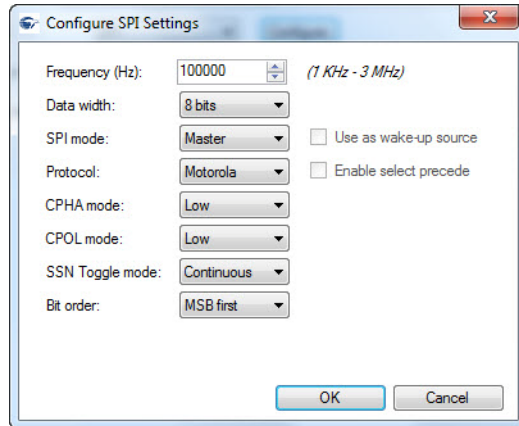

You can configure the following SPI parameters by using the Cypress USB-Serial Configuration Utility:

- Frequency
- Data width
- SPI mode
- Use as wake-up source (slave mode only)
- Protocol
- Enable select precede (TI Protocol only)
- CPHA and CPOL mode (Motorola Protocol only)
- SSN Toggle mode (Motorola Protocol only)
- Bit order

- Frequency**

Default Value: 1 MHz

You can set the SPI operating frequency from 1 kHz to 3 MHz with increments of 1 Hz.

- Data width**

Default Value: 8 bits

You can set the SPI data width from 4 bits to 16 bits in the drop-down menu.

- SPI mode**

Default value: Master

You can configure the SPI mode to either master or slave. To use USB-Serial bridge controller as an SPI slave, the SPI pins (SSEL, SCLK, MOSI, and MISO) of SCB0 or SCB1 should be brought out on the external header J23. See [SPI Interface on page 76](#) for the jumper settings to bring out these pins on the external header J23. Connect the SPI master pins (SSEL, SCLK, MOSI, and MISO) to J23.3 (SSEL), J23.9 (SCLK), J23.7 (MOSI), and J23.5 (MISO), respectively if SCB0 SPI is used. Connect the SPI master pins (SSEL, SCLK, MOSI, and MISO) to J23.6 (SSEL), J23.8 (SCLK), J23.4 (MOSI), and J23.2 (MISO), respectively if SCB1 SPI is used. Refer to the Cypress USB-Serial API documentation for more information on establishing communication between SPI master and SPI slave (USB-Serial bridge controller) or contact [Cypress Technical Support](#).

- Use as Wake-up source**

Default value: Disabled

This parameter is applicable only when the SPI mode is set to Slave.

■ **Protocol**

Default value: Motorola

You can select one of the three SPI protocols:

- Motorola
- Texas Instruments
- National Semiconductors

■ **Enable Select Precede**

Default status: Disabled

This parameter is applicable only when the SPI protocol is set to TI.

■ **CPHA and CPOL mode**

Default Value: Both Low

The CPHA (Clock Phase) and CPOL (Clock Polarity) parameters are available only when the SPI protocol is set to Motorola.

You can set the CPOL and CPHA values to either Low or High from the drop-down menu.

■ **SSN Toggle mode**

Default value: Continuous

This option is available only when the SPI Protocol is set to Motorola.

You can set the SSN (Slave Select n) toggle mode to either Frame or Continuous. SPI EEPROM on the board supports only "Continuous" SSN Toggle mode.

■ **Bit Order**

Default value: MSB first

You can set the bit order to either MSB first or LSB first.

Note Refer to the SPI Mode section in the Cypress USB-Serial Configuration Utility User Guide for more information.

4. Click **OK** to close the **Configure SPI Settings** window and return to the **SCB0** tab.
5. Select **Vendor** as the protocol in the drop-down menu.
6. Notification LEDs are set to None, by default for this board. The notification LED pins are brought out on the external GPIO header J23. You can configure any GPIO as a notification LED by clicking the **Configure** button next to "Notification LED" in the SCB tab and connect an external LED to the assigned GPIO pin on the GPIO header J23.
7. Repeat steps 3 to 5 for SCB1 configuration as SPI.
Note The **Enable SCB to SCB communication** option is not supported on the board.
8. After configuring the SPI interface, click the **Program** button to save the changed SCB0 and SCB1 settings. On successful programming, the "Program Succeeded" message appears.
9. Click **OK** to continue.
10. Click the **Disconnect** button to disconnect the board from the configuration utility.

11. Press the reset switch **SW3** on the board. The controller is reinitialized with the new parameters and the board re-enumerates, as shown in [Figure 3-35](#).

Figure 3-35. CYUSBS236 DVK Enumeration as USB-Serial Bridge Controller in Device Manager

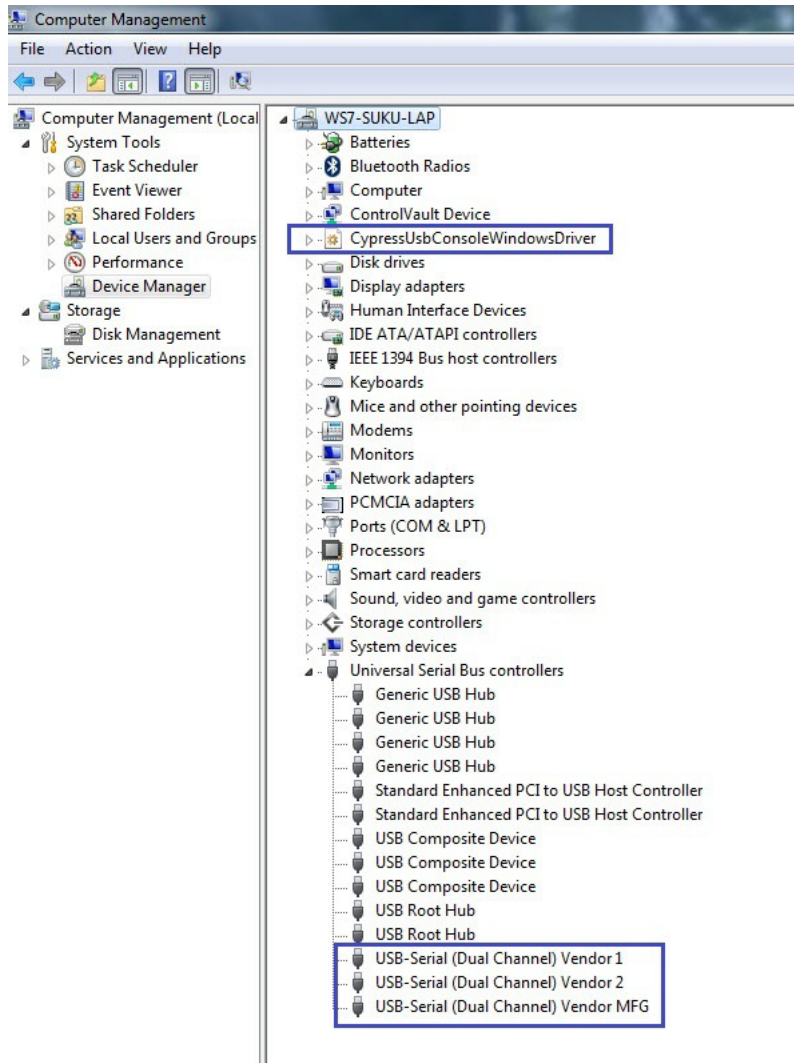

12. The Cypress USB-Serial Configuration Utility is displayed, as shown in [Figure 3-7 on page 20](#).

3.3.5.1 Test Procedure for CYUSBS236 DVK Configured as SPI

1. To test the functionality of the SPI interface, set up the jumpers as listed in [Table 3-4](#) and shown in [Figure 3-36](#) and [Figure 3-37](#).

Table 3-4. Jumper Settings

Jumper	Pins to be Shorted	Function
J17	2 and 5	SCB0_2 (Pin #28) configured for SPI MISO
J19	2 and 3	SCB0_1 (Pin #27) configured for SPI SSEL
J20	2 and 5	SCB0_3 (Pin #29) configured for SPI MOSI
J21	2 and 3	SCB0_4 (Pin #30) configured for SPI SCLK
J24	2 and 5	SCB1_0 (Pin #5) configured for SPI MISO
J25	2 and 5	SCB1_1 (Pin #6) configured for SPI MOSI
J26	2 and 3	SCB1_2 (Pin #7) configured for SPI SSEL
J27	2 and 3	SCB1_3 (Pin #8) configured for SPI SCLK
J29	1 and 2	VBUS selection

Figure 3-36. SCB SPI Jumpers

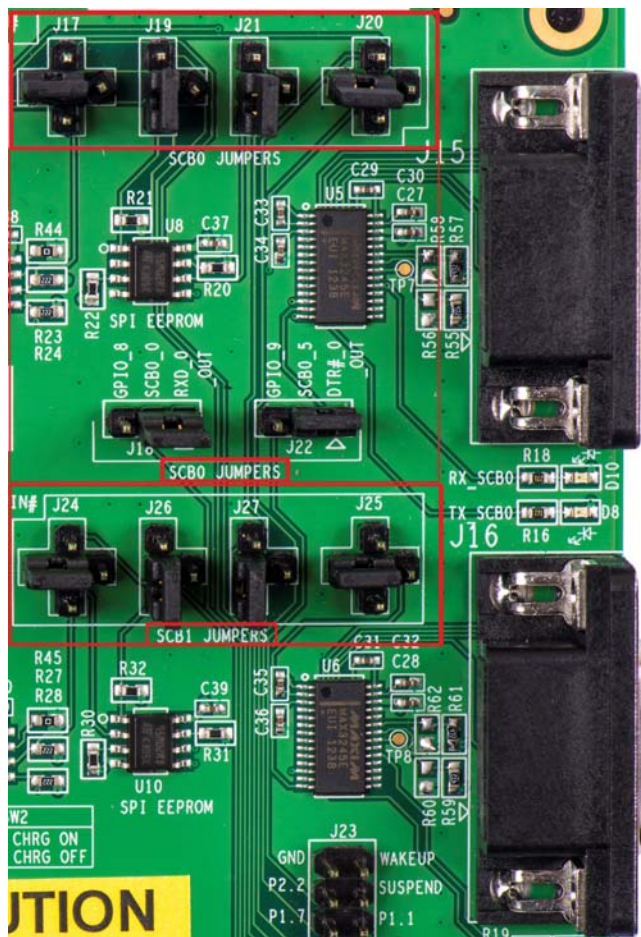
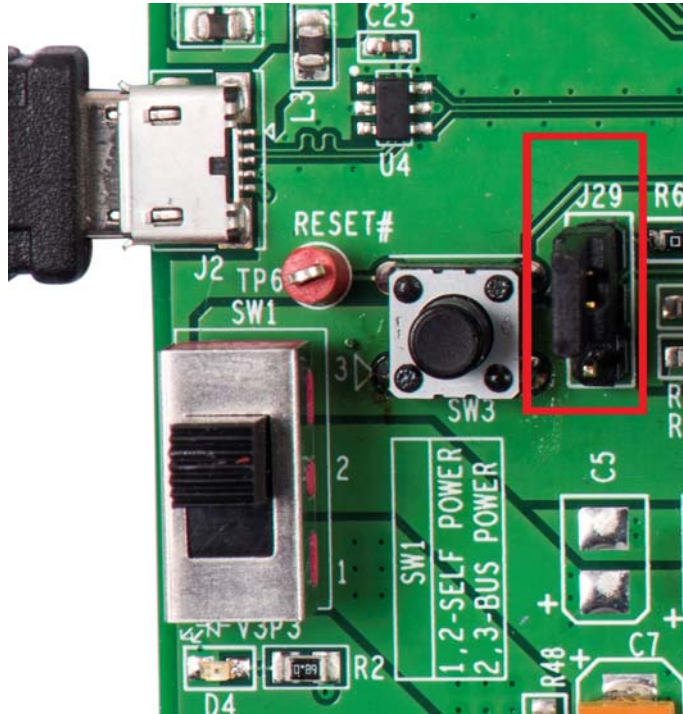
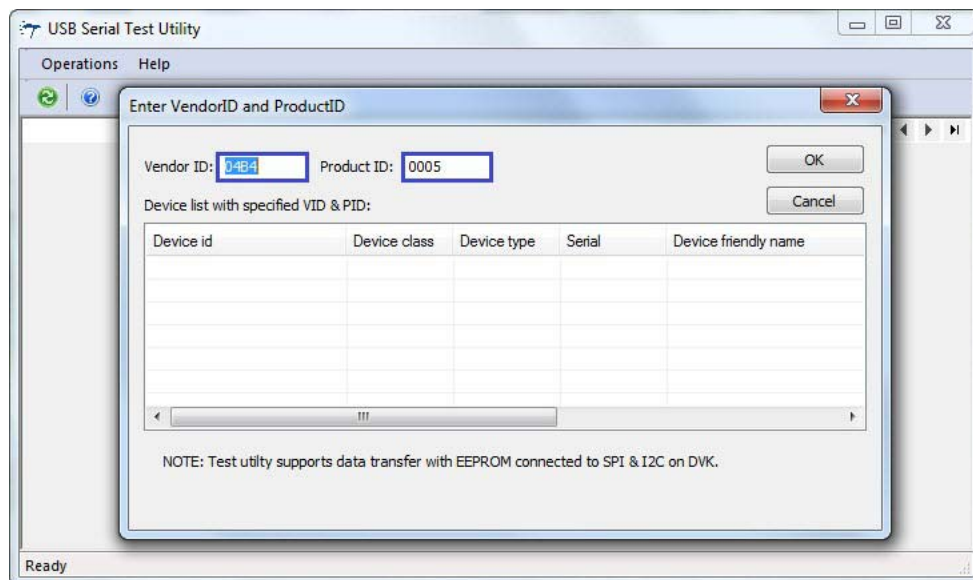

Figure 3-37. VBUS Selection



2. Run the USBSerialTestUtility from **Start > All Programs > Cypress > CYUSBS236 DVK > USBSerialTestUtility**.
3. To use the default Cypress PID, change the Product ID in the text box to '000A'.
Note The user has the option to enter custom Vendor ID and Product ID.

Figure 3-38. Test Utility (VID and PID Selection)



4. The test utility lists the interfaces available on the board for the SPI interface. Click **OK**.

Figure 3-39. Test Utility (PID Change)

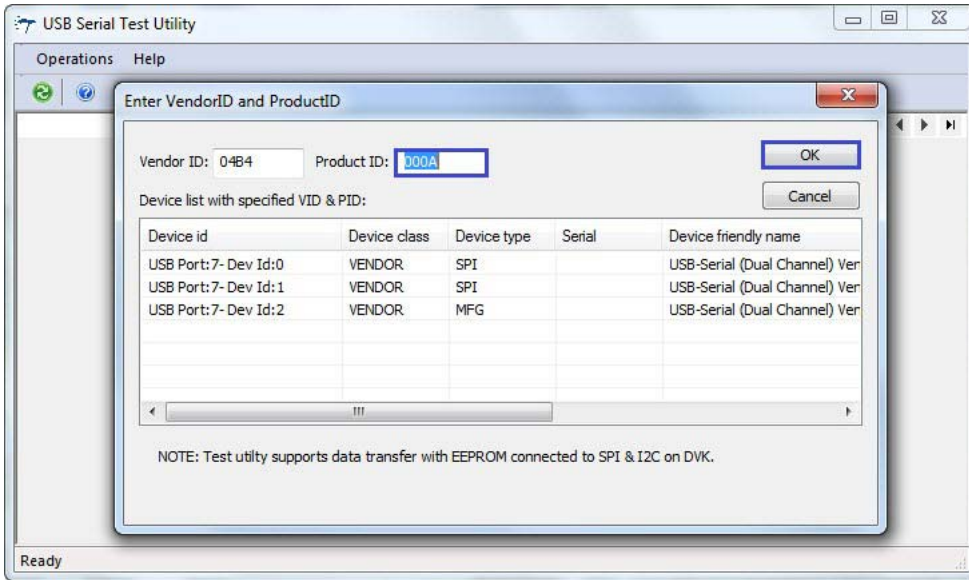

5. The SPI[USB Port:7 - Dev Id:0] tab, which is used to test SCB0 SPI operation is displayed, as shown in Figure 3-40.
6. Enter an EEPROM page address within the range specified in the text box (0x0–0x3FF) and click the **Write data** button. The status bar at the bottom of the window displays the status of the write data operation.

Figure 3-40. Test Utility Data Transfer

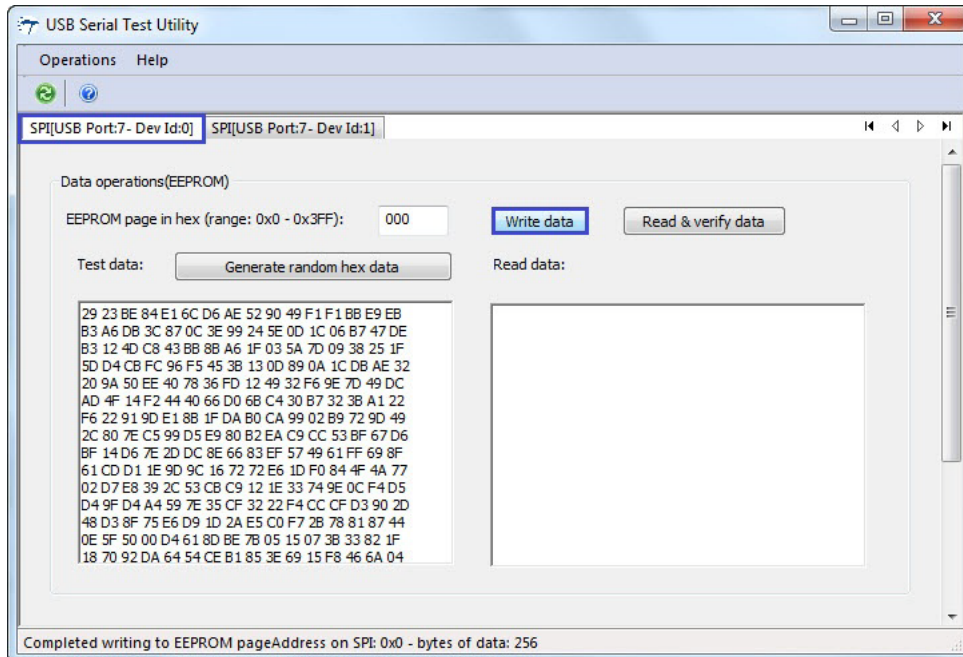

- Click **Read & verify data**. When the data that is written and read back are identical, a data verification successful message appears.

Figure 3-41. Test Utility Data Transfer Verification

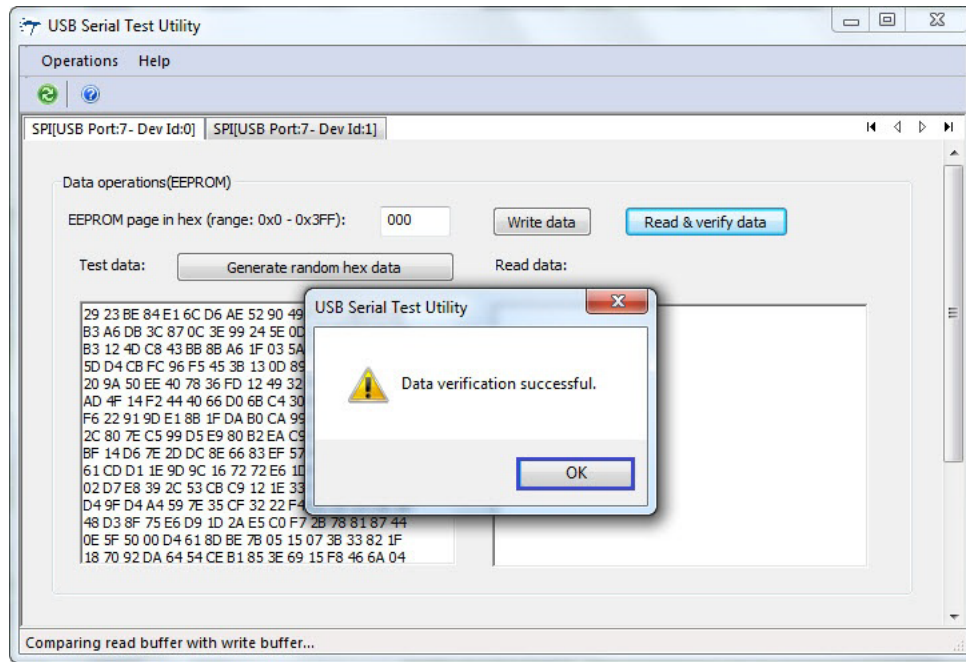

- Click **OK**. The "Data Verification successful" message appears at the bottom of the window.

Figure 3-42. Test Utility Successful Data Transfer

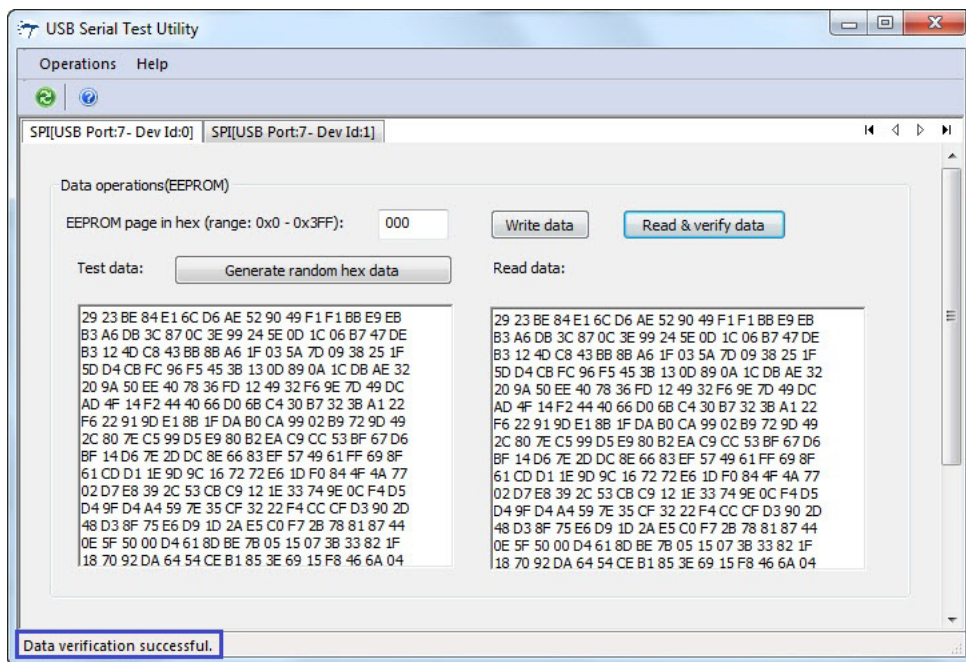

- To test SCB1 SPI operation, click the **SPI[USB Port:7 - Dev Id:1]** tab, as shown in [Figure 3-43](#). Follow steps 6 to 8 to verify the operation.

Figure 3-43. Test Utility SCB1 SPI Tab

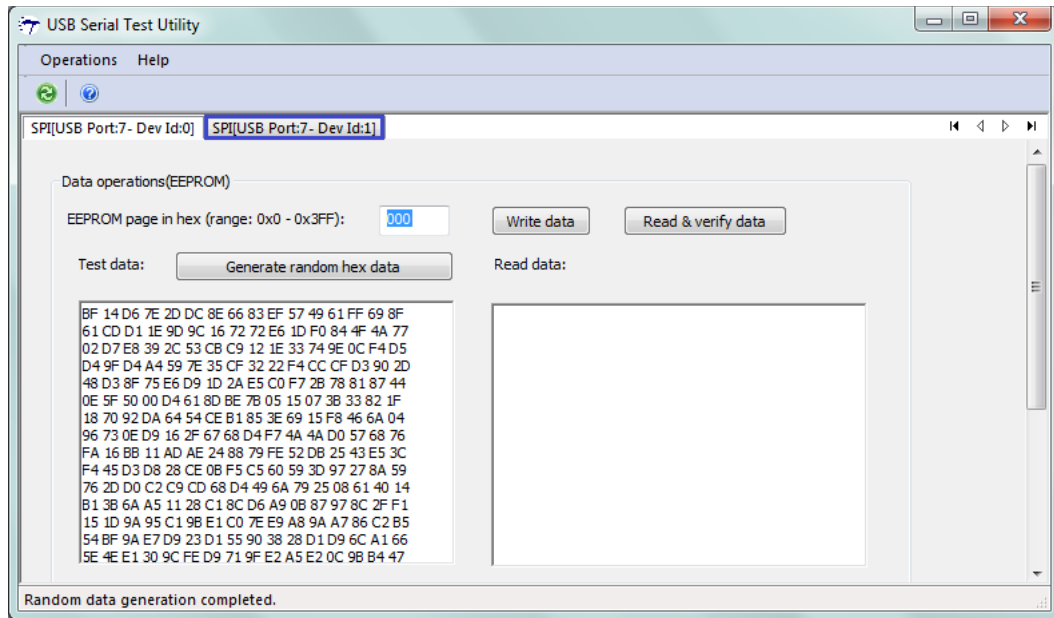

3.3.6 CapSense Configuration

The CY7C65215 USB-Serial bridge controller supports the configurable CapSense functionality, providing best-in-class signal-to-noise ratio (SNR) and water tolerance. This device supports SmartSense™ Auto-Tuning of the CapSense parameters and does not require manual tuning. SmartSense Auto-tuning compensates for printed circuit board (PCB) variations and device process variations. The CYUSBS236 DVK board has two CapSense buttons to evaluate the CapSense functionality.

Follow these steps to view and modify the parameters for the CapSense configuration:

1. Follow steps 1 to 6 in the section [Connecting CYUSBS236 DVK to Cypress USB-Serial Configuration Utility on page 19](#) to connect the board to the Cypress USB-Serial Configuration Utility.
2. Click the **CapSense®/BCD/GPIO** tab. Click the **Configure** button next to **Enable/Disable CapSense®**.

Figure 3-44. CapSense/BCD/GPIO Configuration Tab

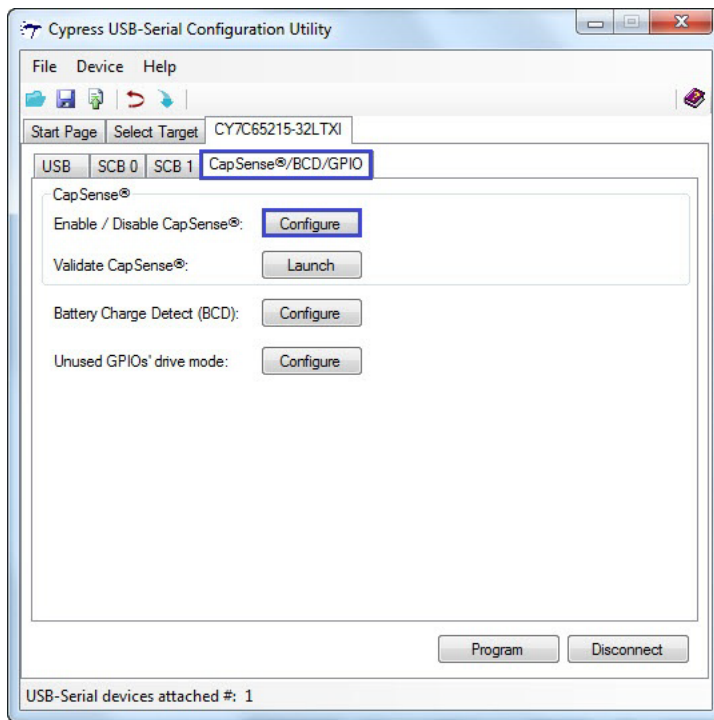

3. To enable the CapSense functionality, check the **Enable CapSense** option. Set **Buttons Needed** to 2, because this board supports two CapSense buttons denoted as B1 assigned to GPIO 06 and B2 assigned to GPIO 07. Assign these GPIOs to **Input Sense GPIO** from the drop-down menu adjacent to **Button 1** and **Button 2**, as shown in [Figure 3-45](#).

Figure 3-45. CapSense Configuration Editor

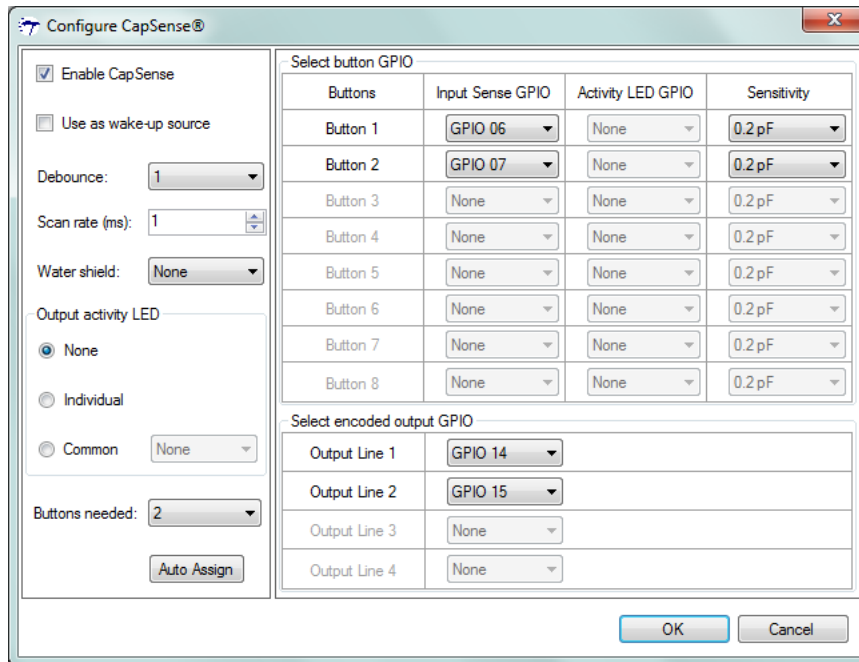

You can configure the following CapSense parameters by using the Cypress USB-Serial Configuration Utility:

- a. Enable CapSense
 - b. Use as wake-up source
 - c. Debounce
 - d. Scan Rate
 - e. Water Shield
 - f. Output activity LED
 - g. Buttons needed
 - h. Input Sense GPIO
 - i. Activity LED GPIO
 - j. Sensitivity
 - k. Select encoded output GPIO
 - l. Auto Assign (Not applicable to this board)
- **Enable CapSense**
Check this box to enable the CapSense block in the device.
 - **Use as wake-up source**
Check this box to wake up the USB-Serial bridge controller from low-power mode when the CapSense button is touched.

■ Debounce

Default Value: 1

Debounce value defines the number of scan cycles (scan rate x number of buttons) a button press needs to be detected by the device before a button press status is reported. For example, if the debounce value is set to two, the device reports a button press status only when it detects the button press for two continuous scan cycles.

Debounce ensures that high-frequency high-amplitude noise does not cause false detection of a pressed button. The debounce value can be set to any value between 1 and 5. By default, the debounce value is set to 1.

■ Scan rate

Default value: 1 ms

Scan rate is the delay (in ms) between two button scans. For example, if the device has three CapSense buttons and scan rate set to 2 ms, each button will be scanned once every 6 ms.

Scan rate can be set to any value between 1 ms and 5 ms. By default, the scan rate is set to 1 ms.

■ Water shield

Default value: Disabled

You can enable the waterproofing feature by selecting any GPIO from the drop-down menu. When this feature is enabled, water droplets on the CapSense button will not be considered as finger touch. The waterproofing design uses a concept called “shield”, which is a conductor placed around the sensors and is connected to a designated shield pin on the device. The shield must be connected to ground by setting jumper J28 to position 2-3 when not used. In the CYUSBS236 board, GPIO 01 is used for water shield operation and the recommended value of sensitivity is 0.2 pF for waterproofing operation. Set the jumper J28 to position 1-2 to test the waterproofing operation.

■ Output activity LED

Default value: None

The output activity LED is an indicator for CapSense button touch. You can configure the LED for no indication by setting it to None; one LED for every button by setting it to Individual; or a common LED for more than one CapSense button.

■ Buttons Needed

Default value: 2

This option defines the number of buttons required for a CapSense operation. This device supports eight buttons but the board supports two CapSense buttons.

■ Input Sense GPIO

This option assigns the GPIO to a CapSense button. On this board, CapSense is assigned to GPIO 06 for button B1 and GPIO 07 for button B2.

■ Activity LED GPIO

Default value: None

This option assigns the GPIO used for the LED indication of the CapSense function. The LED will glow when the assigned CapSense button is touched. On this board, the LEDs are assigned to GPIO 14 and GPIO 15.

■ Sensitivity

Default value: 0.2 pF

This option selects the sensitivity of the CapSense button to detect finger touch. You can set the sensitivity to a value between 0.1 pF to 0.4 pF in increments of 0.1 pF. The recommended value for this board is 0.2 pF.

■ **Select encoded output GPIO**

This option selects the GPIOs that generate a binary-encoded output for an assigned CapSense button. On this board, the encoded output is assigned to GPIO 14 for B1 and GPIO 15 for B2.

■ **Auto assign**

This option automatically assigns the GPIOs from the available free pool of GPIOs.

4. Click **OK** to close the **Configure CapSense®** window and return to the **CapSense®/BCD/GPIO** tab.
5. After configuring CapSense, click the **Program** button to save the changed CapSense settings. On successful programming, the "Program Succeeded" message appears.
6. Click **OK** to continue.
7. Click the **Disconnect** button to disconnect the board from the configuration utility.
8. Press the reset switch **SW3** on the board. The controller is reinitialized with the new parameters and the board re-enumerates, as shown in [Figure 3-46](#).

Figure 3-46. USB-Serial Bridge Controller Enumeration in Device Manager

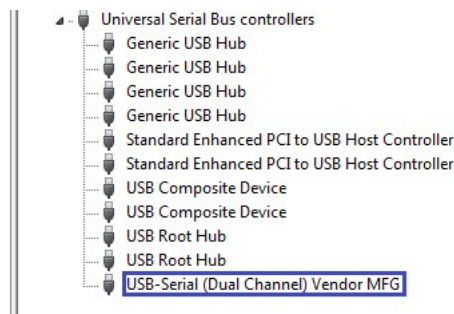

9. The Cypress USB-Serial Configuration Utility is displayed, as shown in [Figure 3-7](#).

3.3.6.1 Test Procedure for CYUSBS236 DVK Configured for CapSense

1. To test the functionality of the CapSense, set up the jumper as listed in [Table 3-5](#) and shown in [Figure 3-47](#) and [Figure 3-48](#).

Table 3-5. Jumper Settings

Jumper	Pins to be Shorted	Function
J28	2 and 3	Waterproofing disabled—Shield is connected to GND
J29	1 and 2	VBUS selection

Figure 3-47. CapSense Jumper (Waterproofing Disabled)

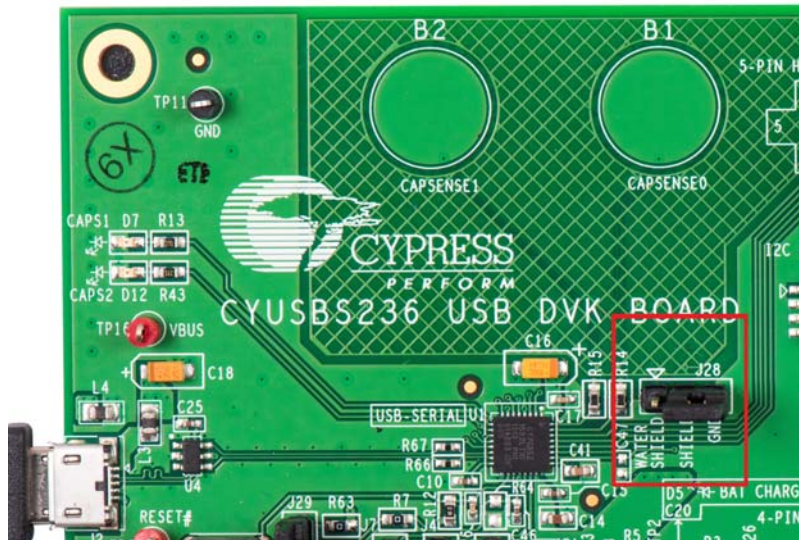
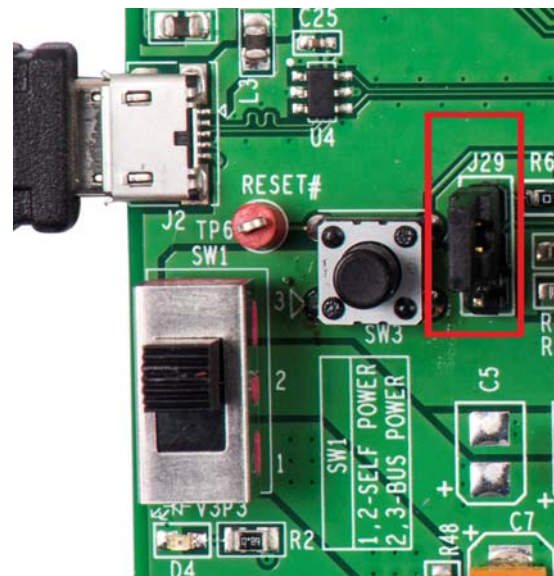

Figure 3-48. VBUS Selection



2. On the board, press the CapSense button **B1**; the LED D7 glows. Now, press button **B2**; LED D12 glows.

3. If you touch both buttons B1 and B2 simultaneously, then LED output depends upon the configuration as follows:
 - a. Case 1 (Default Configuration):
 - Output activity LED** and **Activity LED GPIO** are set to None.
 - Select encoded output GPIOs** are set to GPIO 14 for B1 and GPIO 15 for B2.
 - With this configuration, LED D7 glows. This is because B1 gets higher priority than B2 as multitouch output is not supported in this configuration.
 - b. Case 2 (Custom Configuration):
 - Output activity LED** is set to Individual.
 - Activity LED GPIO** is set to GPIO 14 for B1 and GPIO 15 for B2.
 - Select encoded output GPIOs** are set to available free GPIOs.
 - With this configuration, both LEDs D7 and D12 glow. Multitouch output is supported in this configuration.
4. To validate CapSense using the Cypress USB-Serial Configuration Utility, follow these steps:
 - ❑ Click the **Launch** button next to **Validate CapSense®**.

Figure 3-49. CapSense Validation

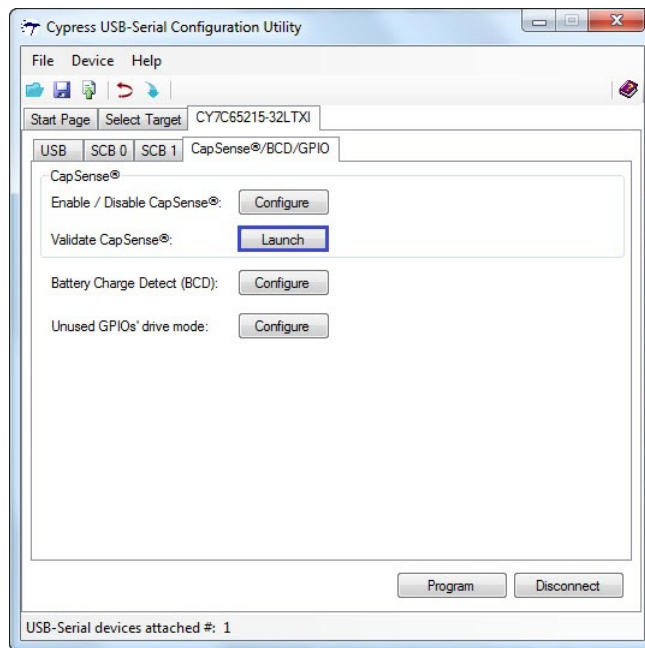

- ❑ Select the **Button Specific Validation** view from the drop-down menu and click the **Load view** button.

Figure 3-50. CapSense Button-specific Validation

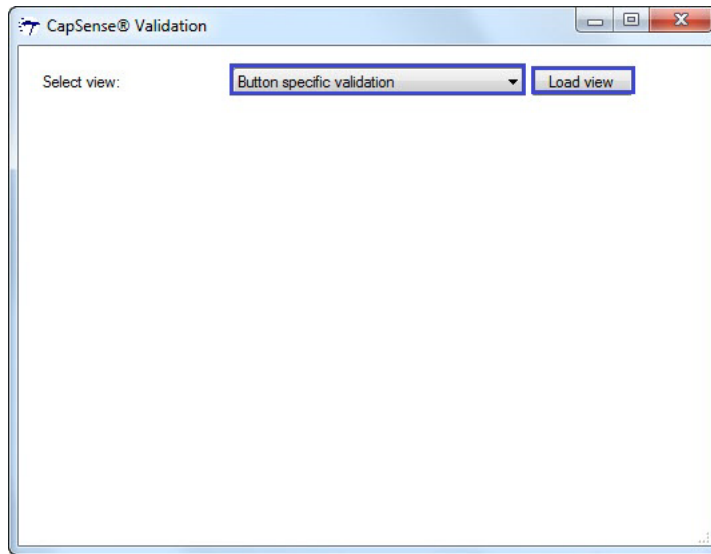

- ❑ Select 1 for **B1** and 2 for **B2** from the drop-down menu against **Select Button**. Select the **RAW count vs Baseline** graph from the drop-down menu. For more information about the options in this window, refer to the *Configuration Utility User Guide.pdf*.
- ❑ The CapSense validation window displays a blue line, which indicates the raw counts without finger touch called the “baseline”. During this event, the button status is OFF.

Figure 3-51. Raw Counts Without Finger Touch

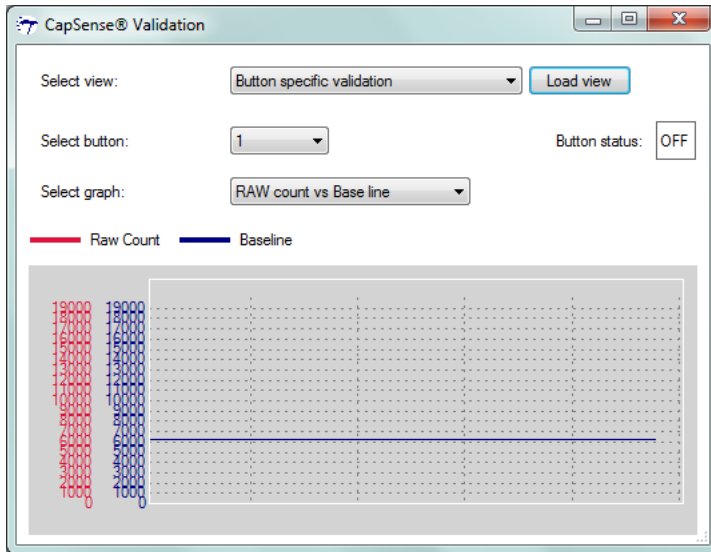

- Touch button B1 with a finger. The CapSense validation window displays a red line, which indicates the raw counts. During this event, the button status is ON.

Figure 3-52. CapSense Finger Touch Output

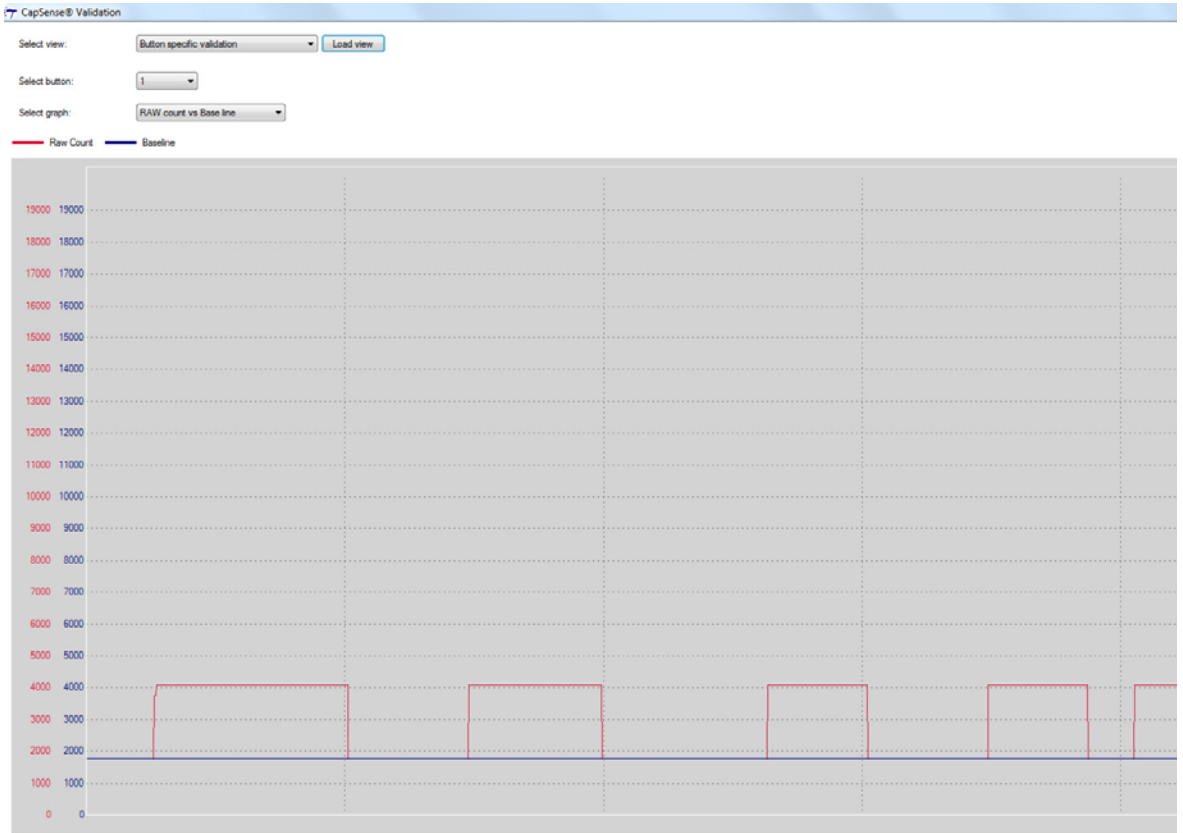

3.3.7 Battery Charger Detection (BCD) Configuration

The battery charger detection logic in the CY7C65215 device will detect the source of power on the USB port and provides indication over the BCD0 and BCD1 GPIOs.

Follow these steps to view and modify the parameters for BCD configuration:

1. Follow steps 1 to 6 in the section [Connecting CYUSBS236 DVK to Cypress USB-Serial Configuration Utility on page 19](#) to connect the board to the Cypress USB-Serial Configuration Utility.
2. Click the **CapSense®/BCD/GPIO** tab. Click the **Configure** button next to **Battery Charge Detect (BCD)** to launch the **Configure BCD** window.

Figure 3-53. CapSense/BCD/GPIO Configuration Tab

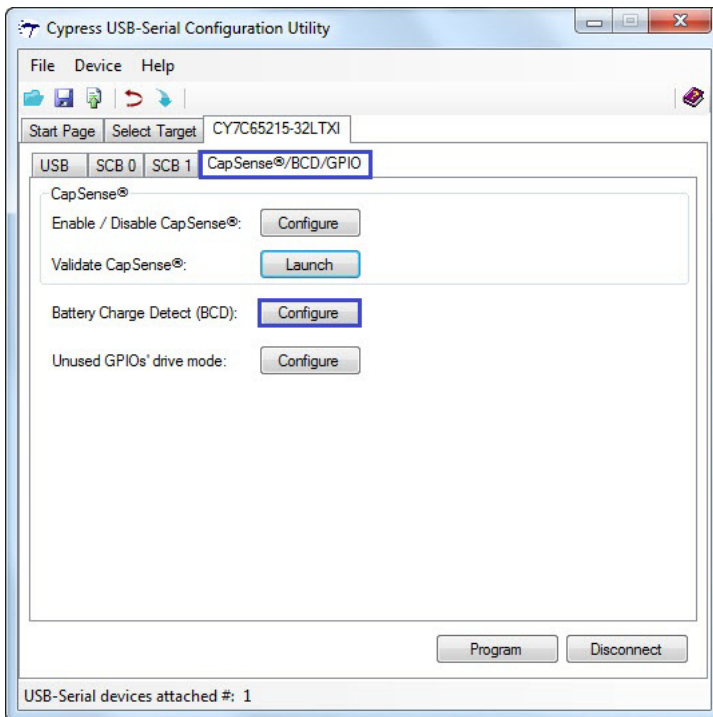

3. To enable the BCD functionality, check the **Enable BCD** option. In the board, GPIO 18, GPIO 16, and GPIO 17 are configured as BCD0, BCD1, and Bus Detect pins, respectively. Assign these GPIOs to BCD0, BCD1, and Bus Detect pins, as shown in [Figure 3-54](#).

Figure 3-54. BCD Configuration Settings

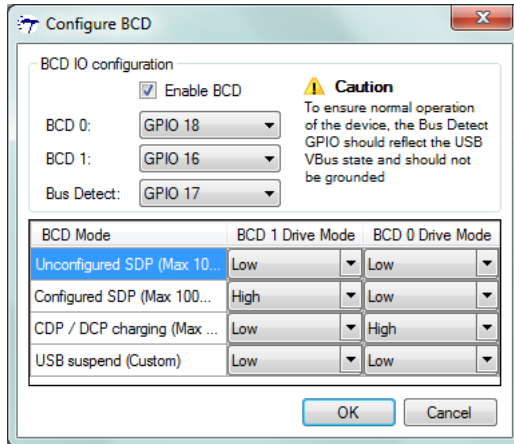

Note The dead/no battery condition is not supported by the CY7C65215 USB-Serial bridge controller.

Configuring the BCD1 and BCD0 drive mode to High in the BCD mode is not a valid condition for this board. If this condition is enabled, the battery charger IC enters into the Suspend mode.

You can configure the following BCD parameters by using the Cypress USB-Serial Configuration Utility:

- a. Enable BCD
- b. BCD0
- c. BCD1
- d. Bus Detect
- e. BCD Drive mode

■ **Enable BCD**

Check this option to enable the BCD block in the device.

■ **BCD0 and BCD1**

You can assign GPIOs to BCD0 and BCD1 from the drop-down menu according to the requirements of the battery charging IC (refer to the battery charging IC datasheet for the truth table).

■ **Bus Detect**

The Bus Detect pin is used to detect the presence of 5 V on VBUS. You must assign a GPIO to the Bus Detect pin from the drop-down menu to detect the USB connection.

■ **BCD Drive mode**

The board has a battery charging IC to charge the Li-Ion battery (not included) at various levels, based on the status of BCD0 and BCD1. A truth table must be designed to meet the battery charging current drawn by the battery-charging IC, depending on the source of the USB power.

The battery-charging IC, MAX8856, on the board sets the charging current, as provided in truth table in [Table 3-6](#).

Table 3-6. BCD Drive Mode Truth Table

BCD0/EN1#	BCD1/EN2#	MODE
0	0	100 mA
0	1	500 mA
1	0	750 mA
1	1	Suspend

Note Depending on the battery-charging IC that you select, the truth table provided in [Table 3-6](#) will change. You must select a battery-charging IC with two control pins to interface with the USB-Serial bridge controller.

4. Click **OK** to close the **Configure BCD** window and return to the **CapSense®/BCD/GPIO** tab.
5. After configuring the BCD, click the **Program** button to save the changed BCD settings. On successful programming, the "Program Succeeded" message appears.
6. Click **OK** to continue.
7. Click the **Disconnect** button to disconnect the board from the configuration utility.

3.3.7.1 Test Procedure for CYUSBS236 DVK Configured for BCD

1. To test the functionality of the BCD, set up the jumpers as listed in [Table 3-7](#) and shown in [Figure 3-55](#) and [Figure 3-56](#).

Table 3-7. Jumper Settings

Jumper	Pins to be Shorted	Function
J4	1 and 2	Battery charge enabled - BCD0
J7	1 and 2	Bus detect
J8	1 and 2	Battery charge enabled - BCD1
J29	1 and 2	VBUS Selection

Figure 3-55. BCD Jumpers

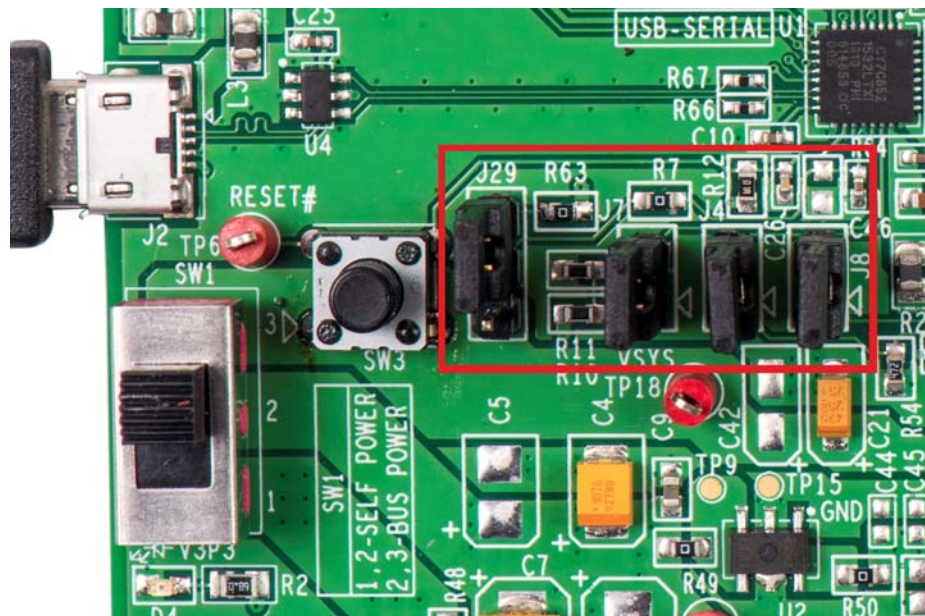
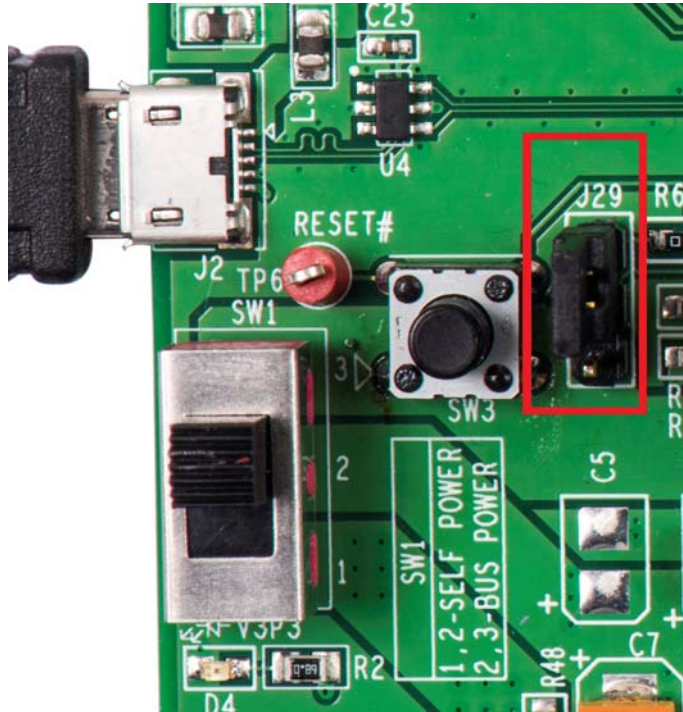
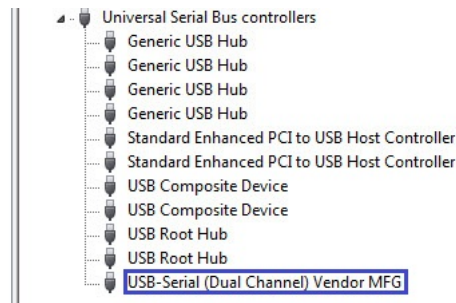

Figure 3-56. VBUS Selection



2. Press the reset switch **SW3** on the board. The controller is reinitialized with the new parameters and the board re-enumerates as shown in [Figure 3-57](#).

Figure 3-57. USB-Serial Bridge Controller Enumeration in Device Manager



3. The Cypress USB-Serial Configuration Utility is displayed, as shown in [Figure 3-7](#).
WARNING The SW2 switch should be in position 2-3 before connecting the battery. Use only the recommended rechargeable Li-ion battery. Check the polarity of the battery connector before connecting to the board.
4. Connect a rechargeable Li-ion battery (not supplied with the board) to the battery connector BH1. This board has been tested with a Tenergy Li-Ion 18650 3.7V 2600 mAh rechargeable battery (MPN: 30011-02).
5. Set SW2 in position 1-2.
6. The battery will charge when its voltage is below the nominal voltage (3.7 V), which is indicated by the LED D5.
Note The Li-Ion battery is not provided with the CYUSBS236 DVK board.
7. Set the SW2 switch to position 2-3 and disconnect the battery.

3.3.8 CYUSBS236 DVK Restore Default Configuration Settings

The CYUSBS236 DVK board features the CY7C65215 USB-Serial bridge controller, which is factory-programmed for dual USB-UART bridge, CapSense, and BCD functionalities. You can reconfigure the device using the Cypress USB-Serial Configuration Utility to meet specific requirements that overwrites the factory configuration.

To restore the board to the factory settings, follow these steps:

1. Follow steps 1 to 6 in the section [Connecting CYUSBS236 DVK to Cypress USB-Serial Configuration Utility on page 19](#) to connect the board to the Cypress USB-Serial Configuration Utility.
2. Click **File > Open Configuration from > Disk**, as shown in [Figure 3-58](#).

Figure 3-58. Select Configuration Window

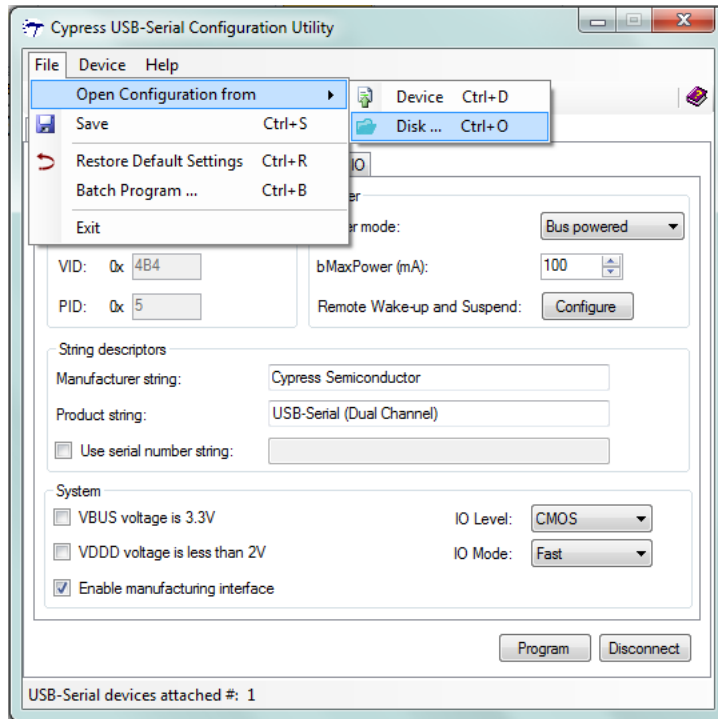

Note The "Restore Default Settings" option will restore the silicon's default settings, which is different from the board default settings.

3. Select the default configuration file from the following location:

<Install directory>\Cypress\CYUSBS236 DVK\1.0\default factory settings\CYUSBS236 USB DVK.cyusb

Figure 3-59. Select Default Configuration File Window

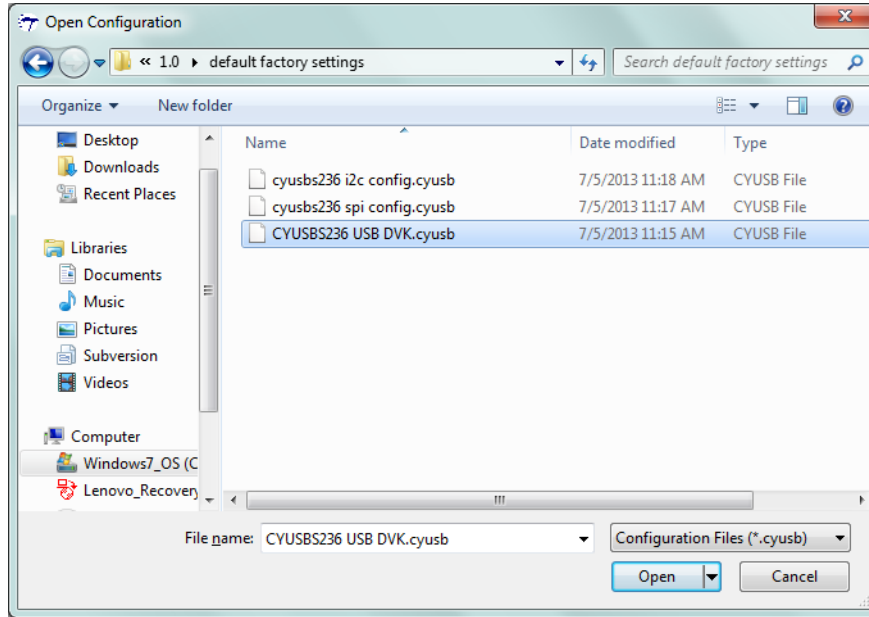

4. After successfully loading the configuration file, the message "Configuration settings were successfully loaded from the file" appears. Click **OK** to continue.

Figure 3-60. Load Configuration

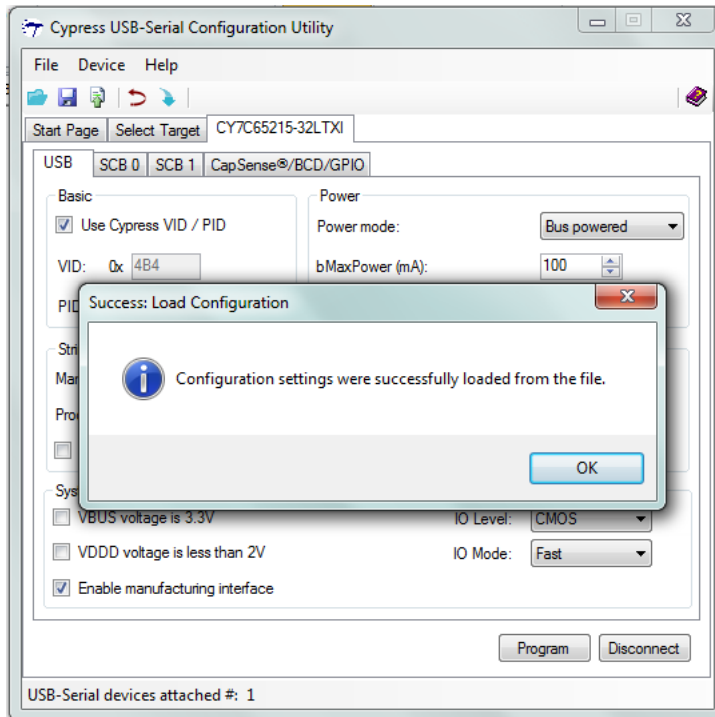

5. Click **Program** to update the configuration settings. On successful programming, the "Program Succeeded" message appears.
6. Click **OK** to continue.
7. Click **Disconnect** to disconnect the board from the configuration utility and press the reset switch **SW3** on the board.
8. The Cypress USB-Serial Configuration Utility is displayed as shown in [Figure 3-7](#); the board enumerates as shown in [Figure 3-5](#).

4. Hardware



4.1 Board Details

The CYUSBS236 DVK board consists of the following components:

- CY7C65215 USB-Serial bridge controller
- Power-supply system
- USB connector
- Two serial communication blocks
 - SCB0 and SCB1 jumpers
 - Two RS-232 line drivers for UART interfaces
 - Two I2C EEPROMs for I2C interfaces
 - Two SPI EEPROMs for SPI interfaces
 - GPIO Header
- Two CapSense buttons
- Li-Ion battery charger
- Reset switch
- LEDs

Figure 4-1. CYUSBS236 DVK Board

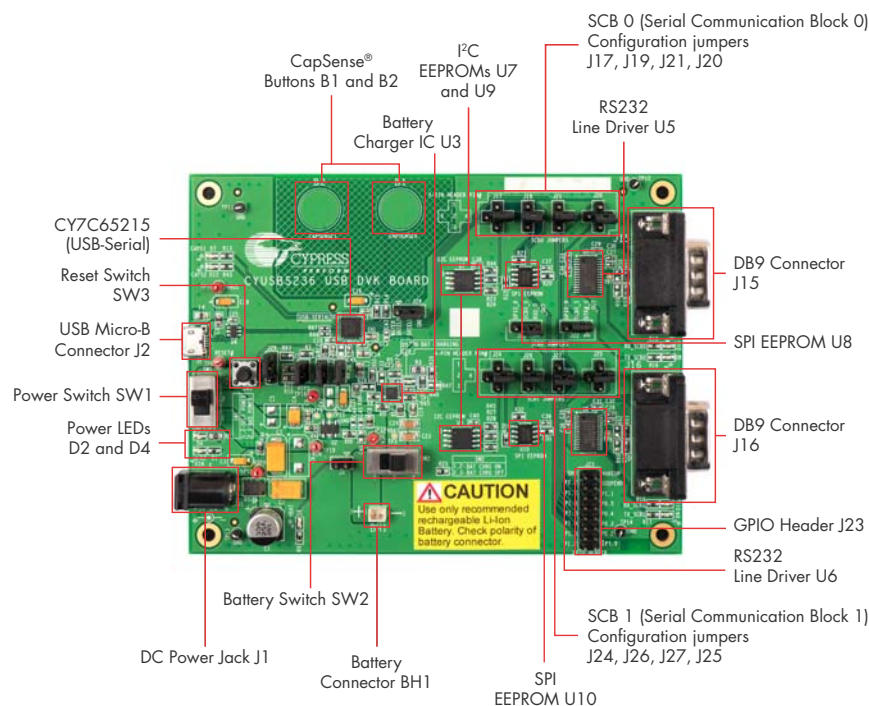

4.2 Theory of Operation

This section provides the block-level description of the CYUSBS236 DVK board.

Figure 4-2. Hardware Block Diagram

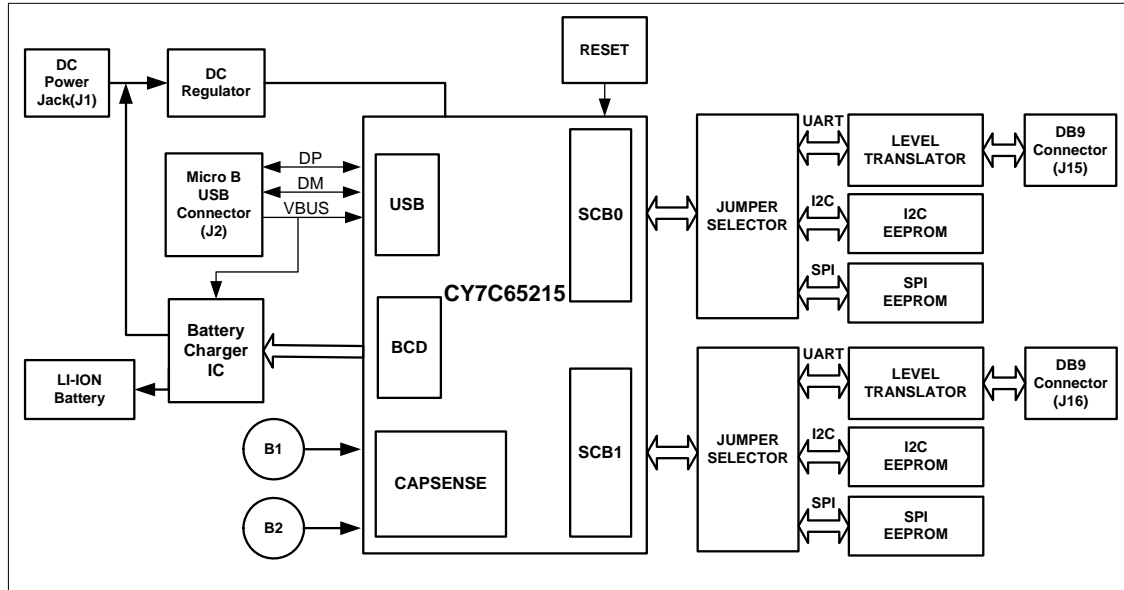

The CY7C65215 is a full-speed USB-Serial bridge controller that offers two configurable serial channels for UART/I2C/SPI interface. This device also integrates the industry-leading CapSense technology (for touch-sensitive key switches) and the USB-IF Battery Charging specification ver. 1.2 (to detect the power source on the USB port). This device is a fixed-function controller, which does not require any changes to the firmware on the embedded products, because the parameters of the controller and serial channels can be modified using an easy-to-use Cypress USB-Serial Configuration Utility.

The CYUSBS236 DVK board communicates through the USB to configure the CY7C65215 USB-Serial bridge controller. The board can function as a dual USB to UART/I2C/SPI bridge. This board also showcases the CapSense and BCD functionalities. The board has two RS-232 line drivers, two I2C EEPROMs, and two SPI EEPROMs to demonstrate the USB-UART, USB-I2C, and USB-SPI bridge functionalities respectively. This board has a set of jumpers that must be configured according to the UART/I2C/SPI functionality. For more information about the jumpers, see [SCB0 and SCB1 Jumpers on page 71](#). The board has a reset switch, which connects to the XRES pin of the CY7C65215 USB-Serial bridge controller and touch-sensitive buttons to demonstrate CapSense. This board also has a battery-charging IC to charge the Li-ion battery, which is connected to the battery connector to demonstrate BCD.

You can power the board from a USB standard-A to micro-B cable, DC power supply, or battery. This board is designed to work at 5 V. The board has two switches; switch SW1 is used to select either self-powered or bus-powered mode and switch SW2 is used to connect the external Li-ion battery to the battery charging circuit.

4.3 Functional Description

This DVK uses the CY7C65215 full-speed USB controller that enables seamless PC connectivity for peripherals with two-channel serial interfaces, such as UART, SPI, and I2C. CY7C65215 also integrates CapSense and BCD-compliant with the USB Battery Charging Specification, Rev. 1.2. It integrates a voltage regulator, an oscillator, and flash memory for storing configuration parameters, offering a cost-effective solution. The CY7C65215 device supports bus-powered and self-powered modes and enables efficient system power management with suspend and remote wake-up signals. It is available in a 32-pin QFN package. For more information, refer to the USB-Serial web page at www.cypress.com/go/usbserial and the USB-Serial datasheet.

4.3.1 Features

- USB 2.0-certified, Full-Speed (12 Mbps)
 - Supports communication driver class (CDC), personal health care device class (PHDC), and vendor-specific drivers
 - BCD compliant with USB Battery Charging Specification, Rev. 1.2 (Peripheral Detect only)
 - Integrated USB termination resistors
- Two-channel configurable UART interface
 - Data rates up to 3 Mbps
 - 256 bytes for each transmit and receive buffer
 - Data format:
 - 7 to 8 data bits
 - 1 to 2 stop bits
 - No parity, even, odd, mark, or space parity
 - Supports parity, overrun, and framing errors
 - Supports flow control using Clear To Send (CTS), Request To Send (RTS), Data Terminal Ready (DTR), Data Set Ready (DSR)
- Two-channel configurable SPI interface
 - Master/slave up to 3 MHz
 - Data width: 4 bits to 16 bits
 - 256 bytes for each transmit and receive buffer
 - Supports Motorola, TI, and National Semiconductor SPI modes
- Two-channel configurable I2C interface
 - Master/slave up to 400 kHz
 - 256 bytes each transmit and receive buffer
 - Supports multi-master I2C
- CapSense
 - SmartSense Auto-tuning enabled

4.3.2 Power-Supply System

The power-supply system on this board is designed to be powered-up from one of the following input sources:

- External 5-V DC power supply (self-powered operation)
- Power from USB bus (bus-powered operation)
- Battery power supply

The USB-Serial bridge controller on this board is powered by 3.3 V. The onboard Low Drop Out regulator provides the required 3.3 V, with input from one of the above sources.

- The board is powered by 5-V DC power supply when:
 - 5-V DC power supply is plugged in DC power jack (J1)
 - SW1 is set to position 1-2
 - SW2 can be set to any position
- The board is powered by USB power supply when:
 - USB standard-A to micro-B cable is plugged in micro-B connector(J2)
 - SW1 is set to position 2-3
 - SW2 can be set to any position
- The board is powered from the battery power supply when:
 - Li-ion rechargeable battery is connected in BH1 connector.
 - SW2 is set to position 1-2
 - SW1 is set to position 2-3

Figure 4-3. Power Supply Block Diagram

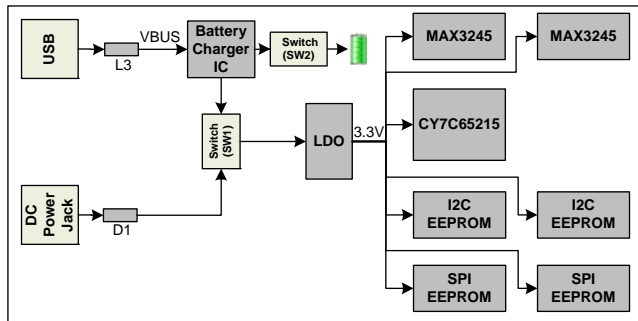

4.3.3 LEDs

The CYUSBS236 DVK board has nine LEDs. D2 and D4 LEDs indicate the power status. D7 and D12 LEDs indicate the CapSense finger touch on buttons B1 and B2, the D5 LED indicates battery charging operation, D8 and D10 LEDs indicate the activity on the TXD and RXD lines of the SCB0 UART, and D9 and D11 LEDs indicate the activity on the TXD and RXD lines of the SCB1 UART.

Figure 4-4. LED D2 (5-V Power On Indication)

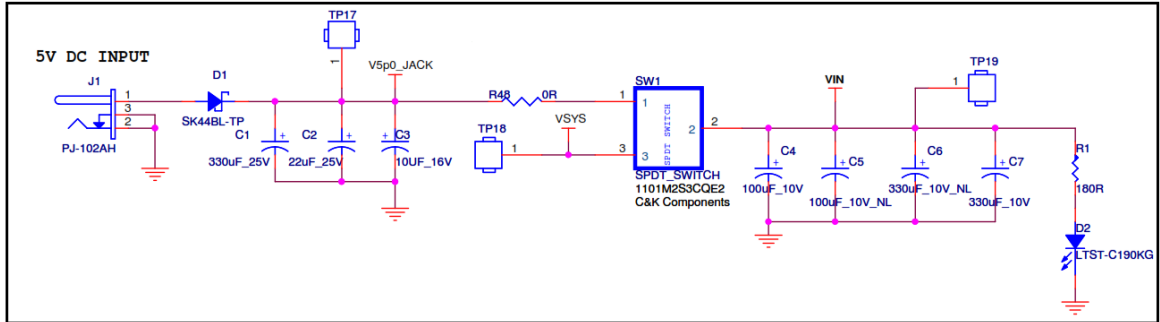

Figure 4-5. LED D4 (3.3-V Power-on Indication)

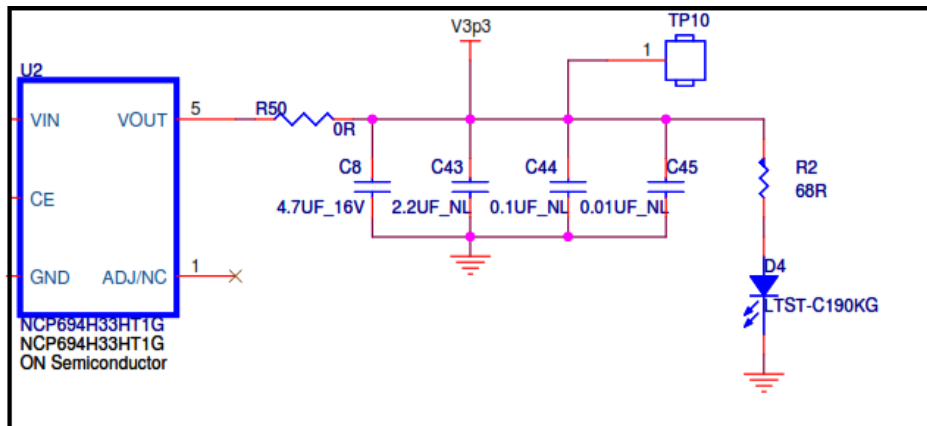

Figure 4-6. LED D5 (Battery Charging Indication)



Figure 4-7. LED D7 and D12 (CapSense Touch Indication)

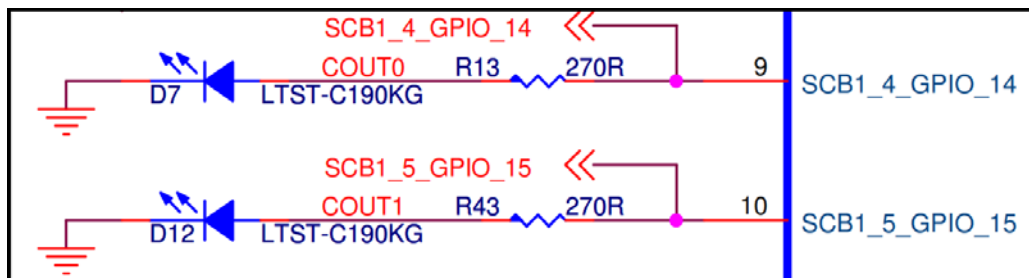

Figure 4-8. LEDs D8 and D10 (TXD and RXD Activity Indication for UART Port SCB0)

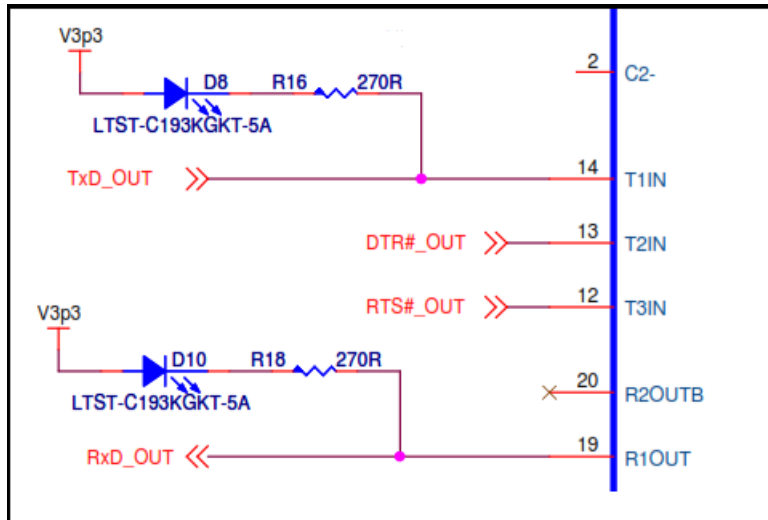
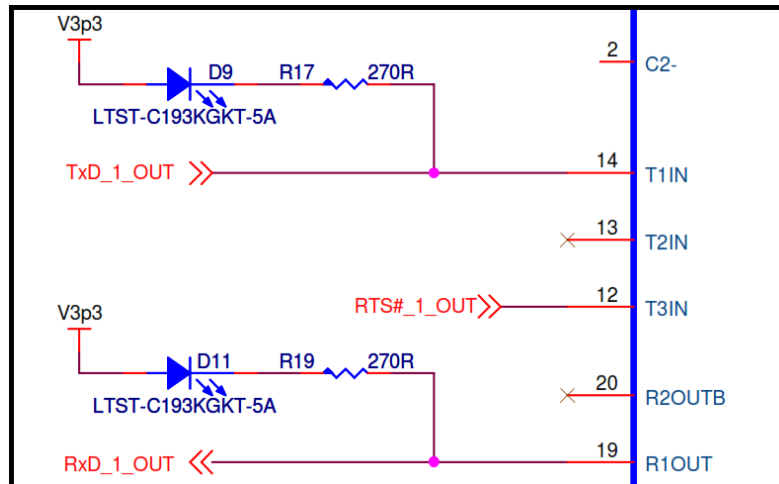

Figure 4-9. LEDs D9 and D11 (TXD and RXD Activity Indication for UART Port SCB1)



4.3.4 USB Connector

A USB standard micro-B connector is used on the board. The shield of this USB connector is connected to the ground and two inductors (L3 and L4) are placed on VBUS and GND pins to reduce the noise from power supply lines. ESD protection is provided on the D+, D-, and VBUS lines.

Figure 4-10. USB Connector

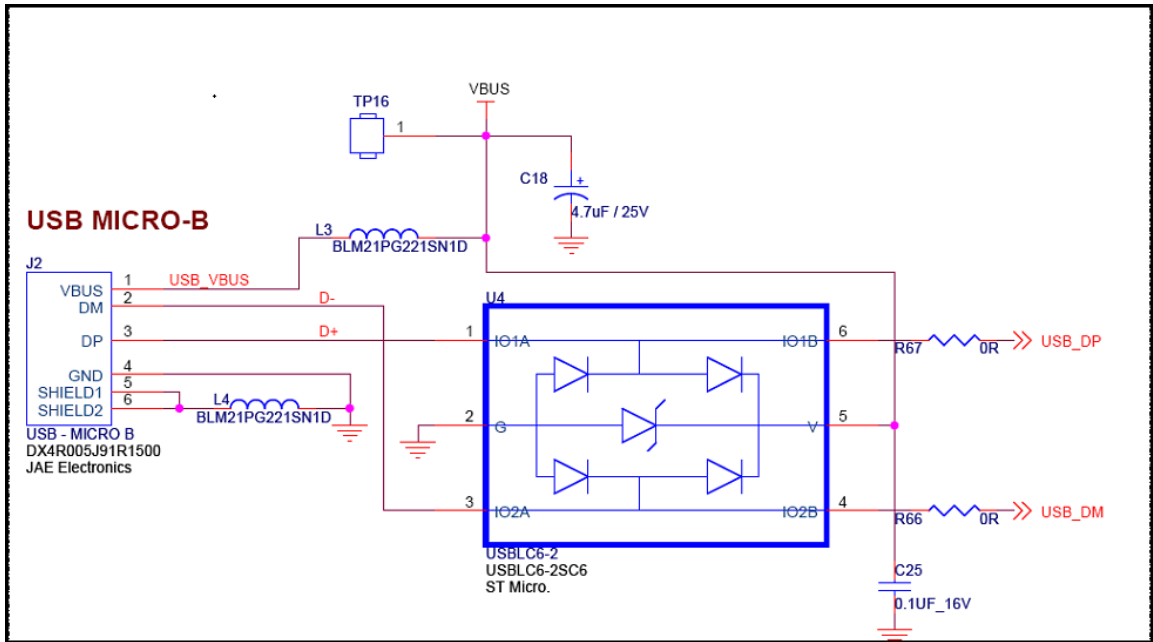

4.3.5 Serial Communication Block (SCB)

The CY7C65215 USB-Serial bridge controller integrates two SCB blocks that can be configured for UART, I2C or SPI interfaces. The board incorporates RS-232 line drivers (U5 and U6), and DB-9 connectors (J15 and J16) to evaluate the UART functionality. EEPROMs (U7 and U9) and EEPROMs (U8 and U10) are used to evaluate the I2C and SPI functionalities on the CYUSBS236 DVK board. As an option, these onboard devices can be disconnected using SCB0 and SCB1 jumpers and the serial interface signals can be made available on header J23 for external connectivity.

4.3.5.1 SCB0 and SCB1 Jumpers

This board has six SCB0 jumpers (J17, J18, J19, J20, J21, and J22) and four SCB1 jumpers (J24, J25, J26, and J27). These jumpers must be configured for USB to UART/I2C/SPI operation. These jumpers are grouped as 3/4/5 pins configurations. [Table 4-1](#) and [Table 4-2](#) provides the jumper configuration details.

Table 4-1. Jumper Configuration for SCB0 (UART/I2C/SPI/GPIO)

	J17	J18	J19	J20	J21	J22
UART	2 – 4	2 – 1	2 – 4	2 – 4	2 – 4	2 – 1
I2C	2 – 3			2 – 3		
SPI	2 – 5			2 – 5	2 – 3	
GPIO HEADER	2 – 1	2 – 3	2 – 1	2 – 1	2 – 1	2 – 3

Table 4-2. Jumper Configuration for SCB1 (UART/I2C/SPI/GPIO)

	J24	J25	J26	J27
UART	2 – 4	2 – 4	2 – 4	2 – 4
I2C	2 – 3	2 – 3		
SPI	2 – 5	2 – 5	2 – 3	2 – 3
GPIO HEADER	2 – 1	2 – 1	2 – 1	2 – 1

Figure 4-11. SCB0 and SCB1 Jumpers

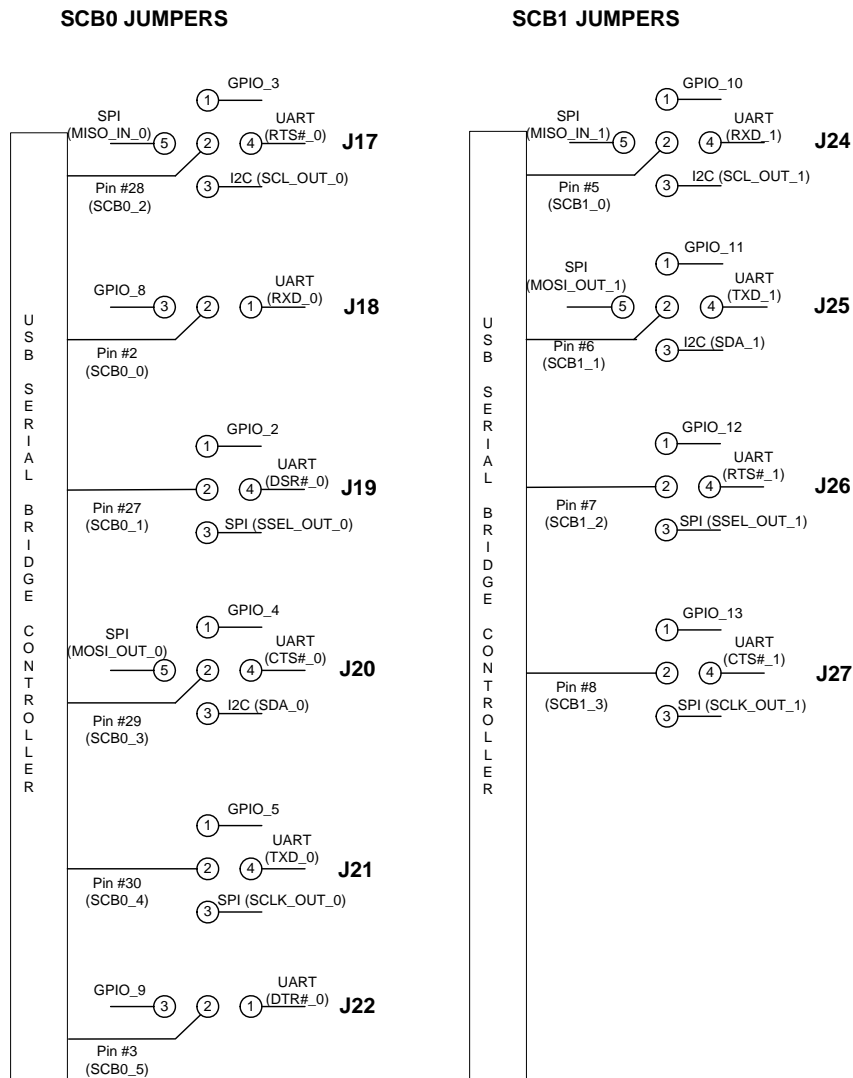

4.3.5.2 RS-232 Interface

This board has two RS-232 line drivers and two DB9 connectors for the RS-232 interfaces, with a maximum baud rate of 1 Mbps (limited by RS-232 line driver). The board includes two LED indicators for RXD (D10 for SCB0 and D11 for SCB1) and TXD (D8 for SCB0 and D9 for SCB1) activity for each RS-232 interface.

Figure 4-12. RS-232 Interface (SCB0)

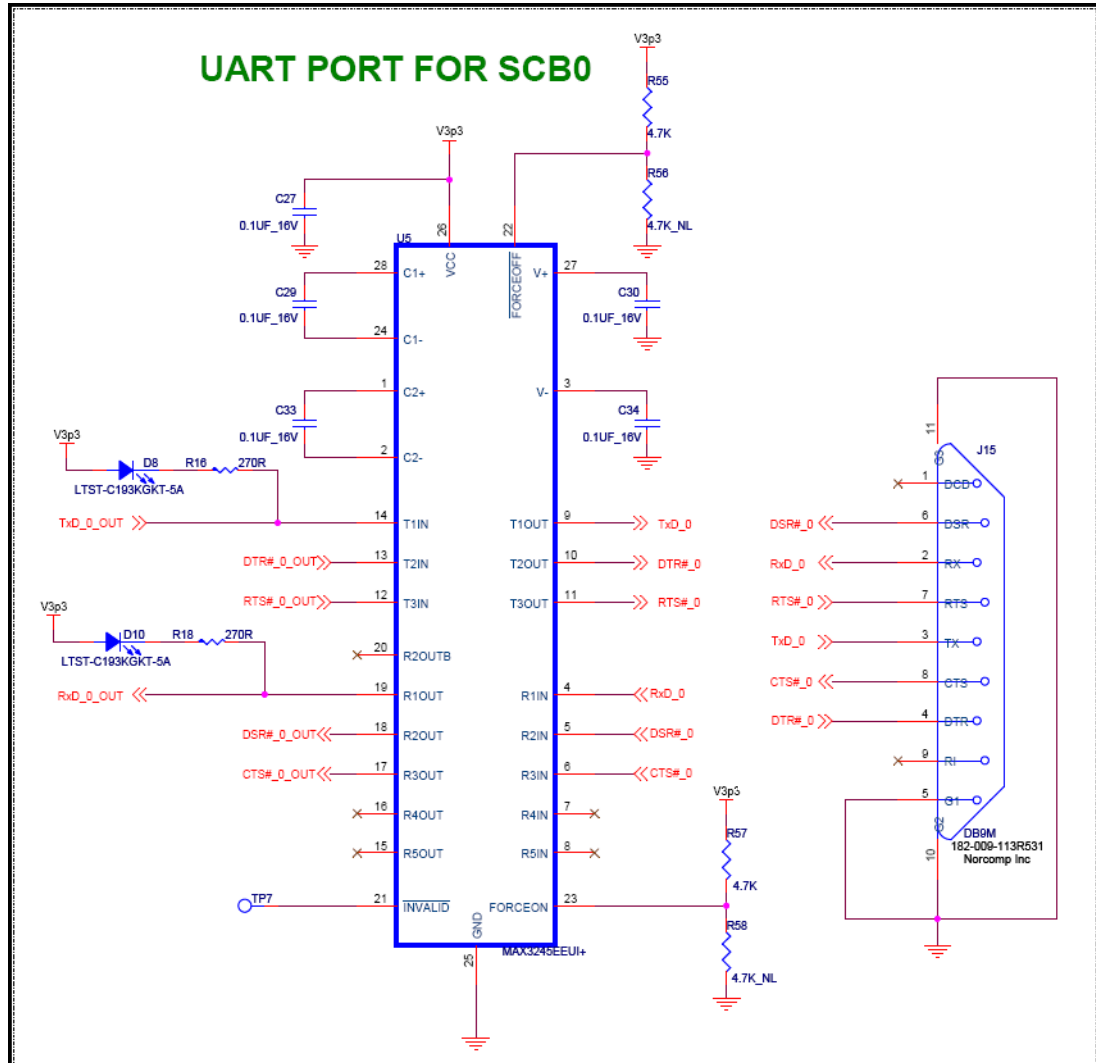
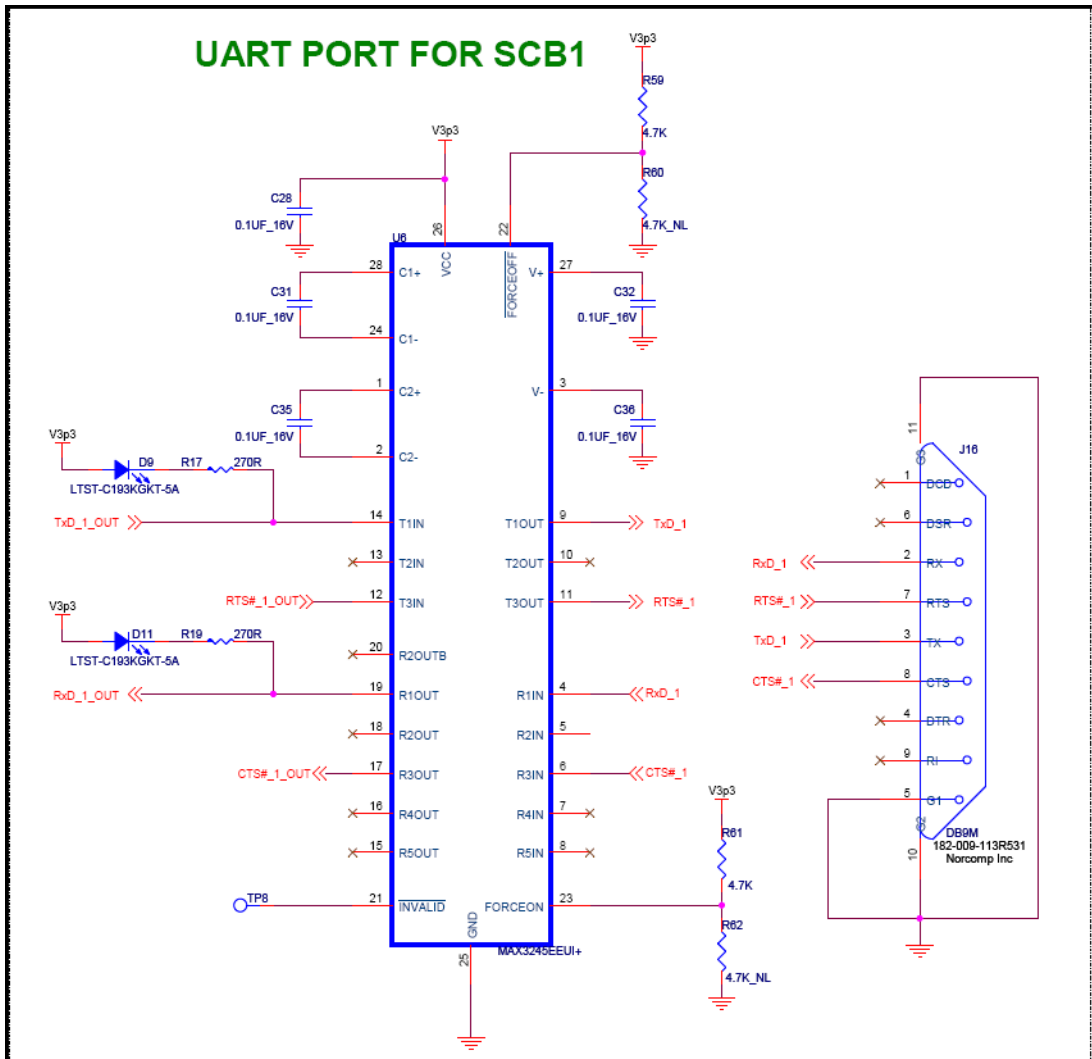

Figure 4-13. RS-232 Interface (SCB1)



4.3.5.3 I2C Interface

The CY7C65215 USB-Serial bridge controller's SCB0 and SCB1 pins can be configured for I2C. These pins are brought out on jumpers (J17 and J20 for SCB0 and J24 and J25 for SCB1) to provide I2C interface. The board has dedicated I2C slave EEPROMs to evaluate the I2C interface. The CY7C65215 USB-Serial bridge controller is configured as an I2C master. The I2C pins (SCL and SDA) of SCB0 can be brought out on the external header J23 by putting the jumper on position 1-2 of J17 and J20. The I2C pins (SCL and SDA) of SCB1 can be brought out on the external header J23 by putting the jumper on position 1-2 of J24 and J25.

Figure 4-14. I2C Interface (SCB0 and SCB1)

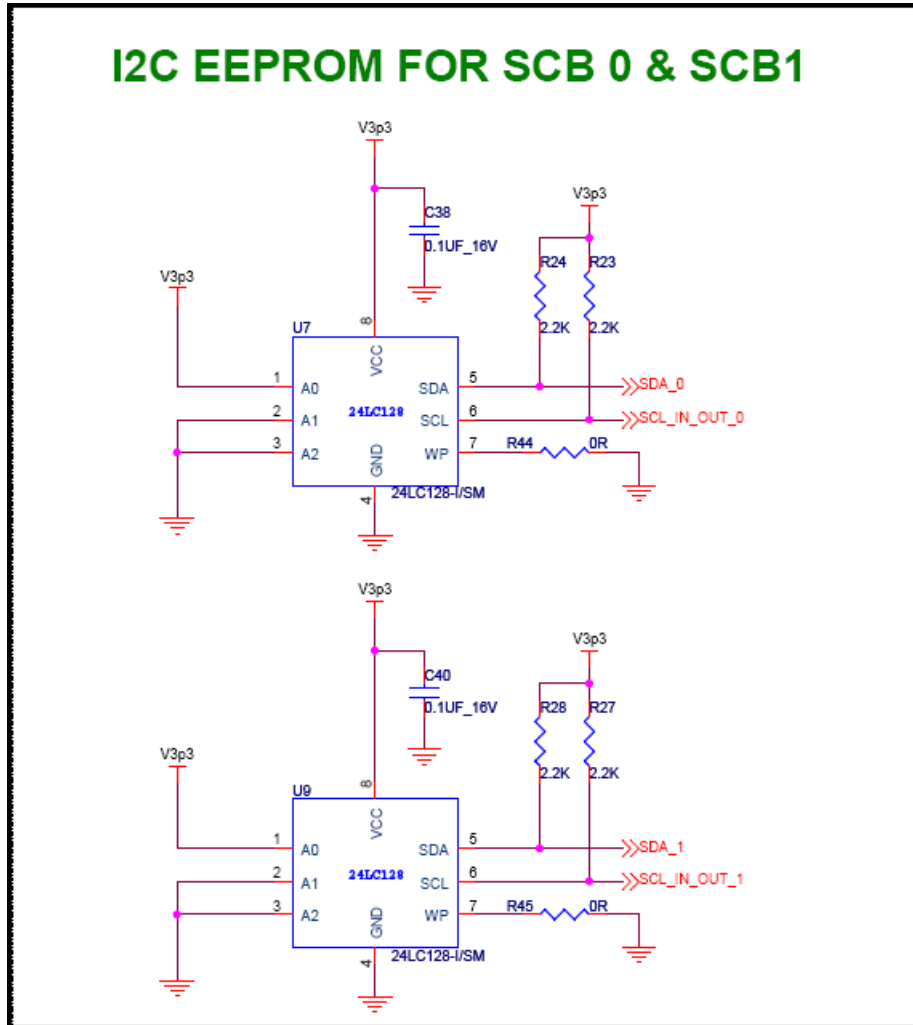

4.3.5.4 SPI Interface

The CY7C65215 USB-Serial bridge controller's SCB0 and SCB1 pins can be configured for SPI. These pins are brought out on jumpers (J17, J19, J20, and J21 for SCB0 and J24, J25, J26, and J27 for SCB1) to provide the SPI interface. The board has dedicated SPI slave EEPROMs to evaluate the SPI interface. The CY7C65215 USB-Serial bridge controller is configured as a SPI master. The SPI pins (SSEL, MISO, MOSI, and SCLK) of SCB0 can be brought out on the external header J23 by putting the jumper on position 1-2 of J17, J19, J20, and J21. The SPI pins (SSEL, MISO, MOSI, and SCLK) of SCB1 can be brought out on the external header J23 by putting the jumper on position 1-2 of J24, J25, J26, and J27.

Figure 4-15. SPI Interface (SCB0 and SCB1)

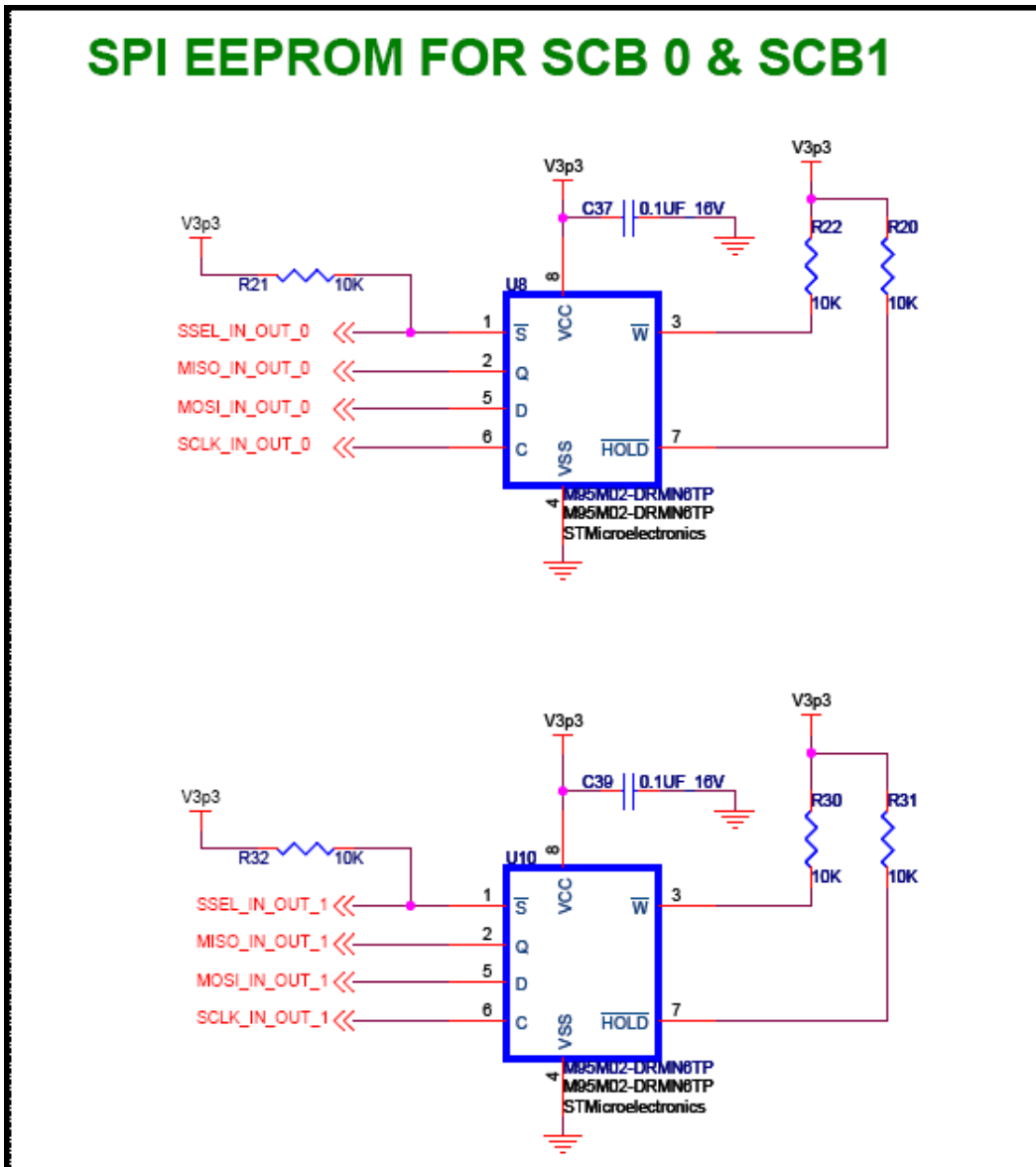

4.3.5.5 GPIO Header

The CY7C65215 USB-Serial bridge controller's SCB0 and SCB1 pins can be configured as GPIO. These pins are brought out on external header J23. Thirteen pins on this header (J23.1 to J23.12 and J23.14) can be used as I/O pins and the two pins (J23.13 and J23.15) have fixed functions for "Suspend" and "Wakeup". See [USB Configuration on page 21](#) for more details on Suspend and Wakeup. J23.16 on the GPIO header is the GND pin. This device can act as JTAG master. JTAG pins are brought out on this GPIO header. Refer to the device datasheet for additional information about JTAG operation on the USB-Serial device.

Figure 4-16. GPIO Header

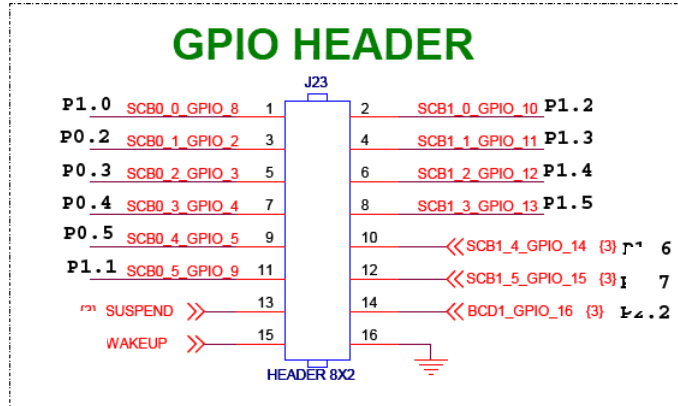

Table 4-3. Serial Communication Block (SCB0) Configuration

Pin	Serial Port 0	Mode 0 ^a	Mode 1	Mode 2	Mode 3	Mode 4	Mode 5	Mode 6
		6-pin UART	4-pin UART	2-pin UART	SPI Master	SPI Slave	I ² C Master	I ² C Slave
2	SCB0_0	RxD_0	RxD_0	RxD_0	GPIO_8	GPIO_8	GPIO_8	GPIO_8
27	SCB0_1	DSR#_0	GPIO_2	GPIO_2	SSEL_OUT_0	SSEL_IN_0	GPIO_2	GPIO_2
28	SCB0_2	RTS#_0	RTS#_0	GPIO_3	MISO_IN_0	MISO_OUT_0	SCL_OUT_0	SCL_IN_0
29	SCB0_3	CTS#_0	CTS#_0	GPIO_4	MOSI_OUT_0	MOSI_IN_0	SDA_0	SDA_0
30	SCB0_4	TxD_0	TxD_0	TxD_0	SCLK_OUT_0	SCLK_IN_0	GPIO_5	GPIO_5
3	SCB0_5	DTR#_0	GPIO_9	GPIO_9	GPIO_9	GPIO_9	GPIO_9	GPIO_9

a. Device configured in Mode 0 as default. Other modes can be configured through USB-Serial Configuration Utility.

Table 4-4. Serial Communication Block (SCB1) Configuration

Pin	Serial Port 1	Mode 0 ^a	Mode 1	Mode 2	Mode 3	Mode 4	Mode 5	Mode 6	Mode 7
		6-pin UART	4-pin UART	2-pin UART	SPI Master	SPI Slave	I ² C Master	I ² C Slave	JTAG Master
5	SCB1_0	RxD_1	RxD_1	RxD_1	MISO_IN_1	MISO_OUT_1	SCL_OUT_1	SCL_IN_1	TDI
6	SCB1_1	TxD_1	TxD_1	TxD_1	MOSI_OUT_1	MOSI_IN_1	SDA_1	SDA_1	TDO
7	SCB1_2	RTS#_1	RTS#_1	GPIO_12	SSEL_OUT_1	SSEL_IN_1	GPIO_12	GPIO_12	TMS
8	SCB1_3	CTS#_1	CTS#_1	GPIO_13	SCLK_OUT_1	SCLK_IN_1	GPIO_13	GPIO_13	TCK
9	SCB1_4	DSR#_1	GPIO_14	GPIO_14	GPIO_14	GPIO_14	GPIO_14	GPIO_14	TRST#
10	SCB1_5	DTR#_1	GPIO_15	GPIO_15	GPIO_15	GPIO_15	GPIO_15	GPIO_15	GPIO_15

a. Device configured in Mode 0 as default. Other modes can be configured through USB-Serial Configuration Utility.



4.3.6 CapSense Buttons

The board has two CapSense touch buttons B1 and B2, which are connected to GPIO_06 and GPIO_07 and a Cmod (modulation) capacitor connected to pin GPIO_0. This board supports the waterproofing feature of CapSense. When the waterproofing feature is enabled, the water droplets on the sensor will not be sensed. This helps to prevent any accidental sensing of the button due to water droplets.

Waterproofing enables using a shield electrode to compensate for the water drops influence on the sensor at the hardware level. This electrode is located around the sensing electrodes. When water film is present on the device overlay surface, the coupling between the shield and sensing electrodes is increased. The shield electrode allows to reduce the influence of parasitic capacitance, which gives more dynamic range for processing sense capacitance changes. This shield must be connected to a designated shield pin on the device to function or to the ground when not used. On the board, the shield can be connected to the designated shield pin (GPIO_1) by setting jumper J28 (position 1-2); it can be connected to ground by setting jumper J28 (position 2-3). Refer to the CapSense Design Guide for further details related to CapSense.

Figure 4-17. CapSense Schematic

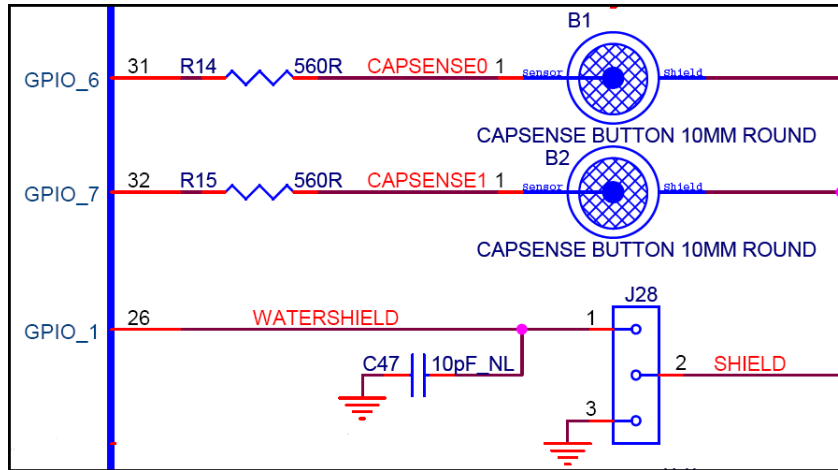

4.3.7 Battery Charger Detection

The CY7C65215 USB-Serial bridge controller integrates battery charging detection, which is compliant with the USB-IF Battery Charging Specification, Rev 1.2. This device detects the source of power on the USB port and provides voltage indication (logic high or logic low) over BCD0 and BCD1 pins to select the different battery charging modes. The BCD0 and BCD1 pins are connected to EN1# and EN2# of the battery charging IC MAX8856. Depending on the BCD0 and BCD1 logic, the different charging modes are selected, as given in Table 4-5. The board is designed with a Li-ion battery charger IC (MAX8856) that has two logic inputs (EN1#, EN2#) to control the amount of current drawn from the USB source to charge the battery. For more details about the battery charger operation, refer to the chip (MAX8856) datasheet.

Table 4-5 shows the amount of current drawn in different modes by the battery charging IC.

Table 4-5. MAX 8856 (Battery Charging IC) BCD Drive Modes

EN1#	EN2#	MODE
0	0	100 mA
0	1	500 mA
1	0	750 mA
1	1	Suspend

Figure 4-18. Battery Charger Circuit

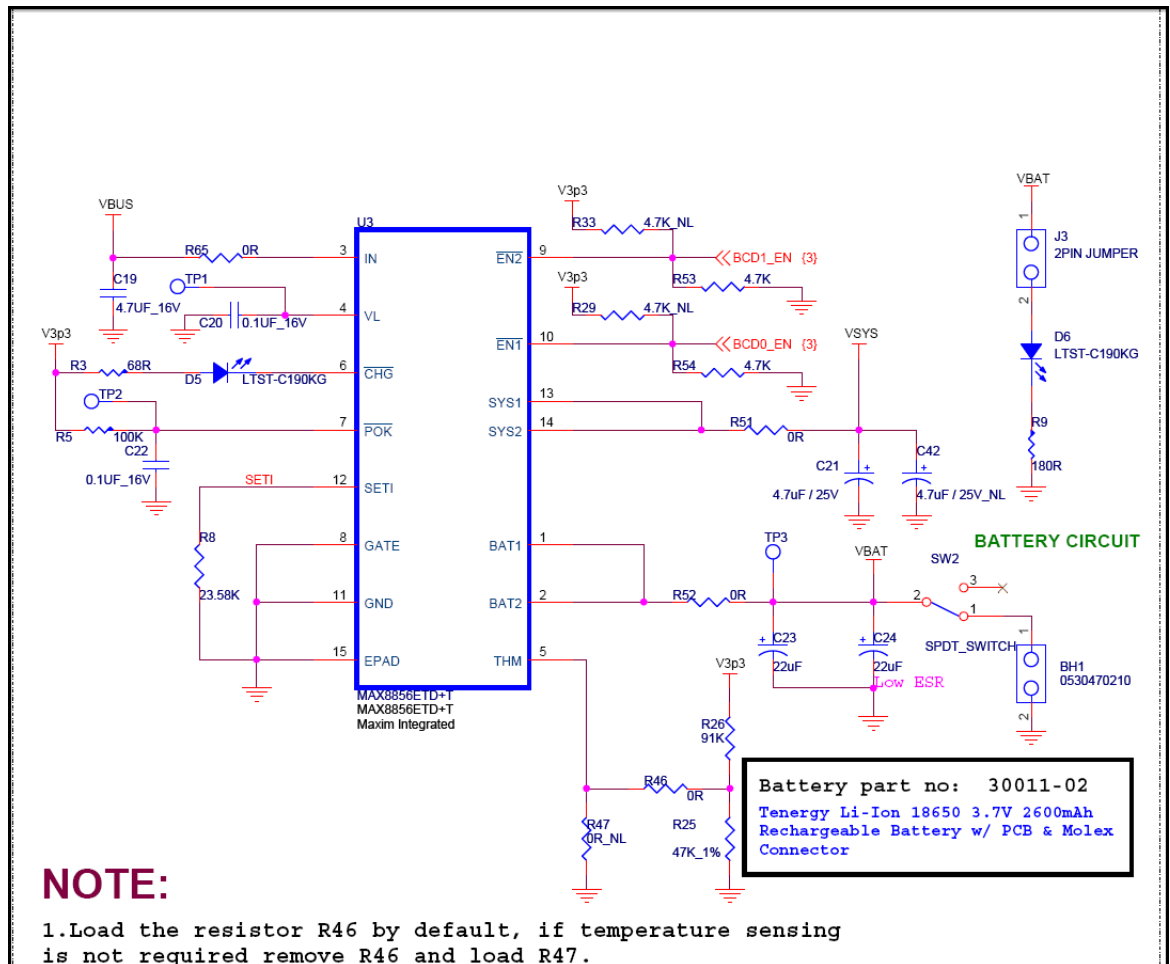

4.3.8 Reset Switch

The reset switch is connected to the XRES pin of the CY7C65215 USB-Serial bridge controller and is used to reset the device. A reset is required when a new set of configuration parameters are programmed.

Figure 4-19. Reset Schematic

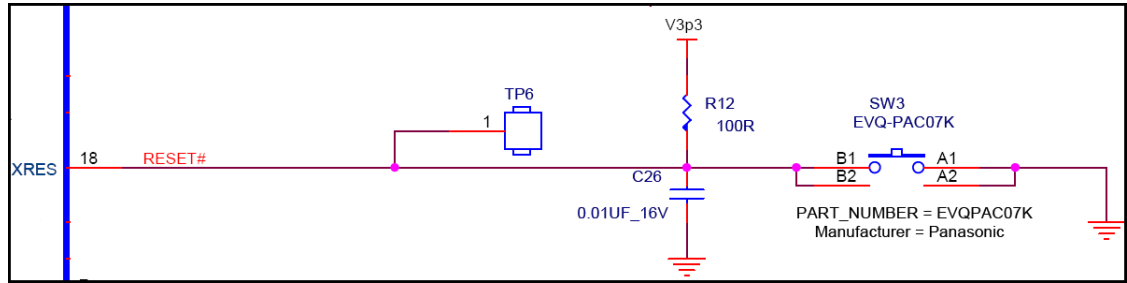

5. Additional Information



5.1 Using USB-Serial on a Mac OS

Note The CYUSBS236 DVK board should be configured for USB to UART, I2C, or SPI on Windows OS before using on Mac OS.

5.1.1 Using CYUSBS236 DVK in Communications Device Class (CDC) Mode

The CY7C65215 USB-Serial bridge controller automatically binds to the AppleUSBCDC driver, which is the CDC class driver in Mac OS X.

Follow these steps to use the CDC mode for Cypress USB-Serial UART on a Mac OS:

1. Connect the CYUSBS236 DVK board to Mac. The Mac CDC class driver (AppleUSBCDC) automatically binds to the device. After the driver successfully binds, a device node is created as `/dev/tty.usbmodem<number>`.
2. Install a standard terminal emulator, such as SerialTools to test the UART functionality of the device. SerialTools is available in the Apple App Store.
3. Open the SerialTools application. In the **Serial port** option, select the Cypress USB-Serial UART device node created in step 1.

Figure 5-1. Connecting USB-Serial Device in Serial Tools

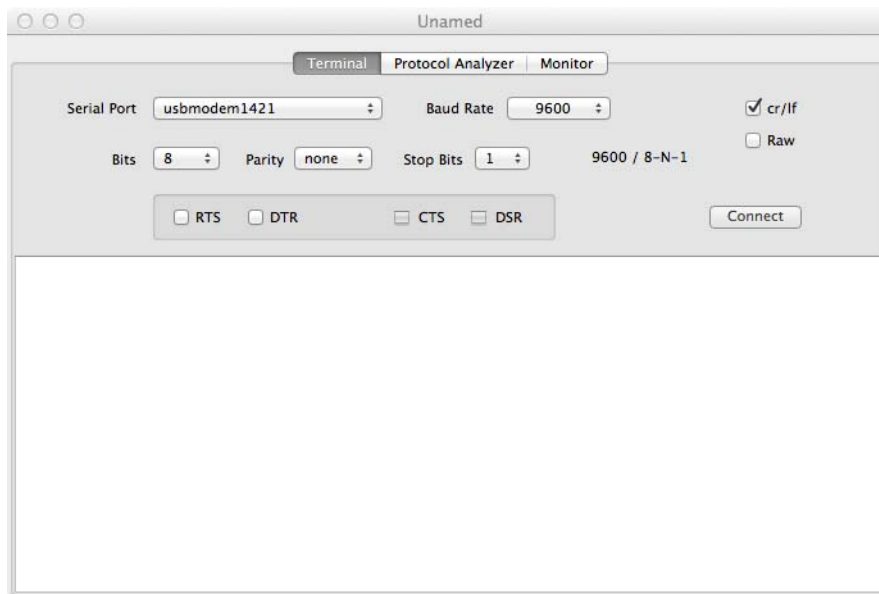

4. Configure the UART settings, such as baud rate, stop bits, data width, and parity.
5. For simple loopback tests, short the RXD and TXD pins on the DVK.
6. Click **Connect** to start communication with the device.

7. Type **Cypress** in the text field. Because the local echo is always enabled in the SerialTools application, the entered characters will be displayed twice.

Figure 5-2. Serial Tools Application: Loopback Test Output

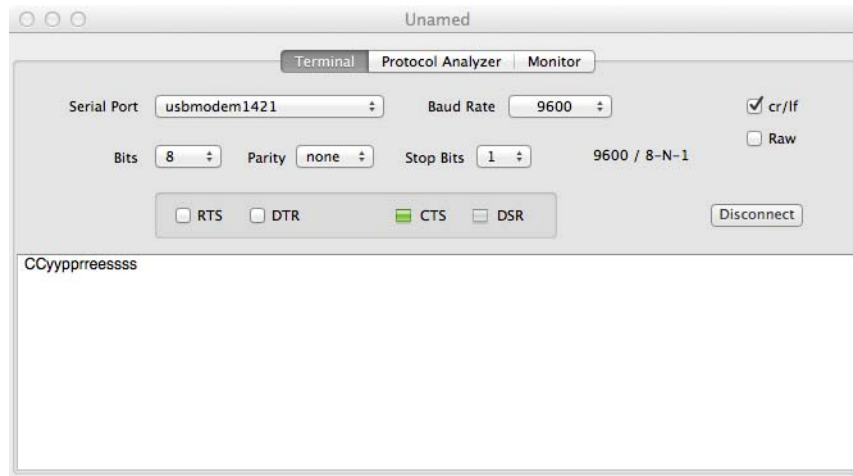

5.1.2 Using CYUSBS236 DVK in Vendor Mode

Follow these steps to use the CYUSBS236 DVK board in the Vendor mode on a Mac OS.

1. Download the latest *USB-Serial SDK for Mac* from www.cypress.com/go/usbserial.
2. Follow the steps listed in the README file provided in the software development kit (SDK) to compile and install the library.
3. When the library is installed, execute the test utility (CyUSBSerialTestUtility) to verify the communication with the CYUSBS236 DVK board.
4. For a detailed API description, refer to *CyUSBSerial API Documentation.pdf* in the <Install_Directory>/common/doc folder of the SDK.

A. Appendix



A.1 Schematic

The schematic for the CYUSBS236 DVK board is available at www.cypress.com/go/CYUSBS236.

Figure A-1. Schematic

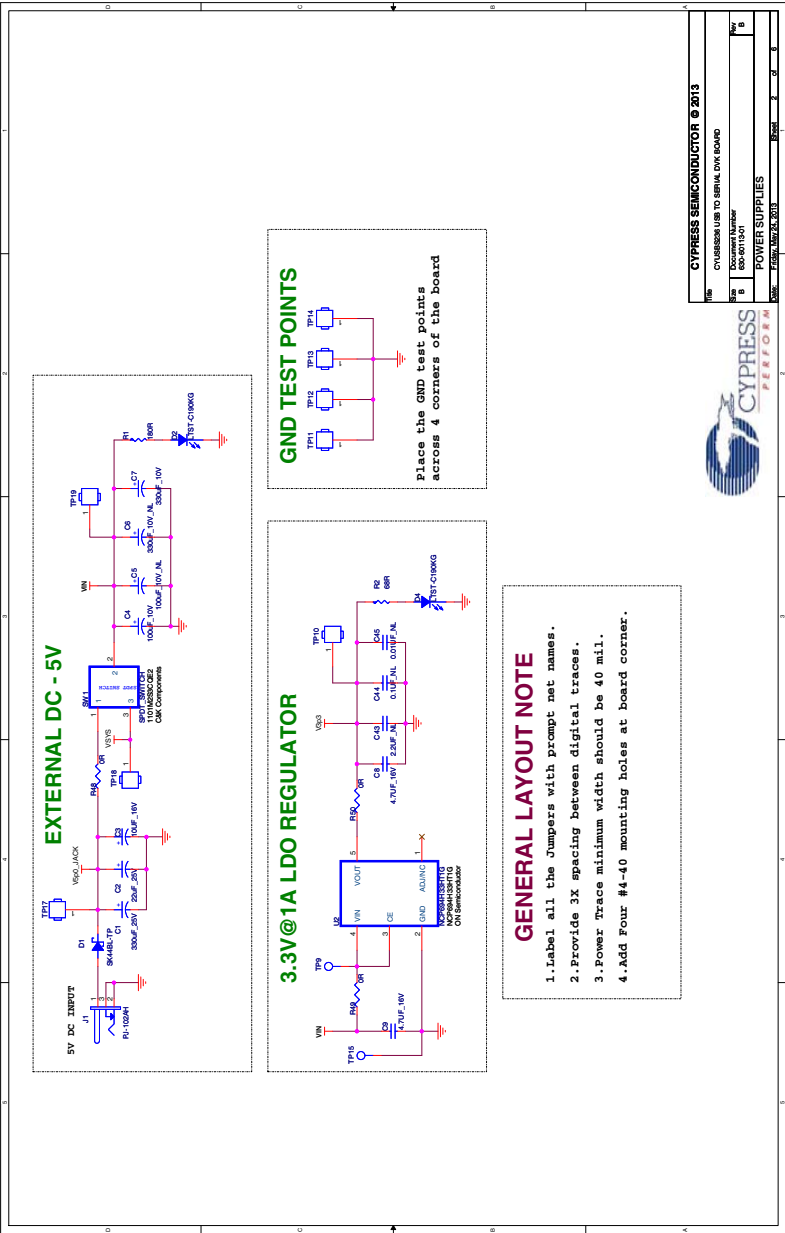
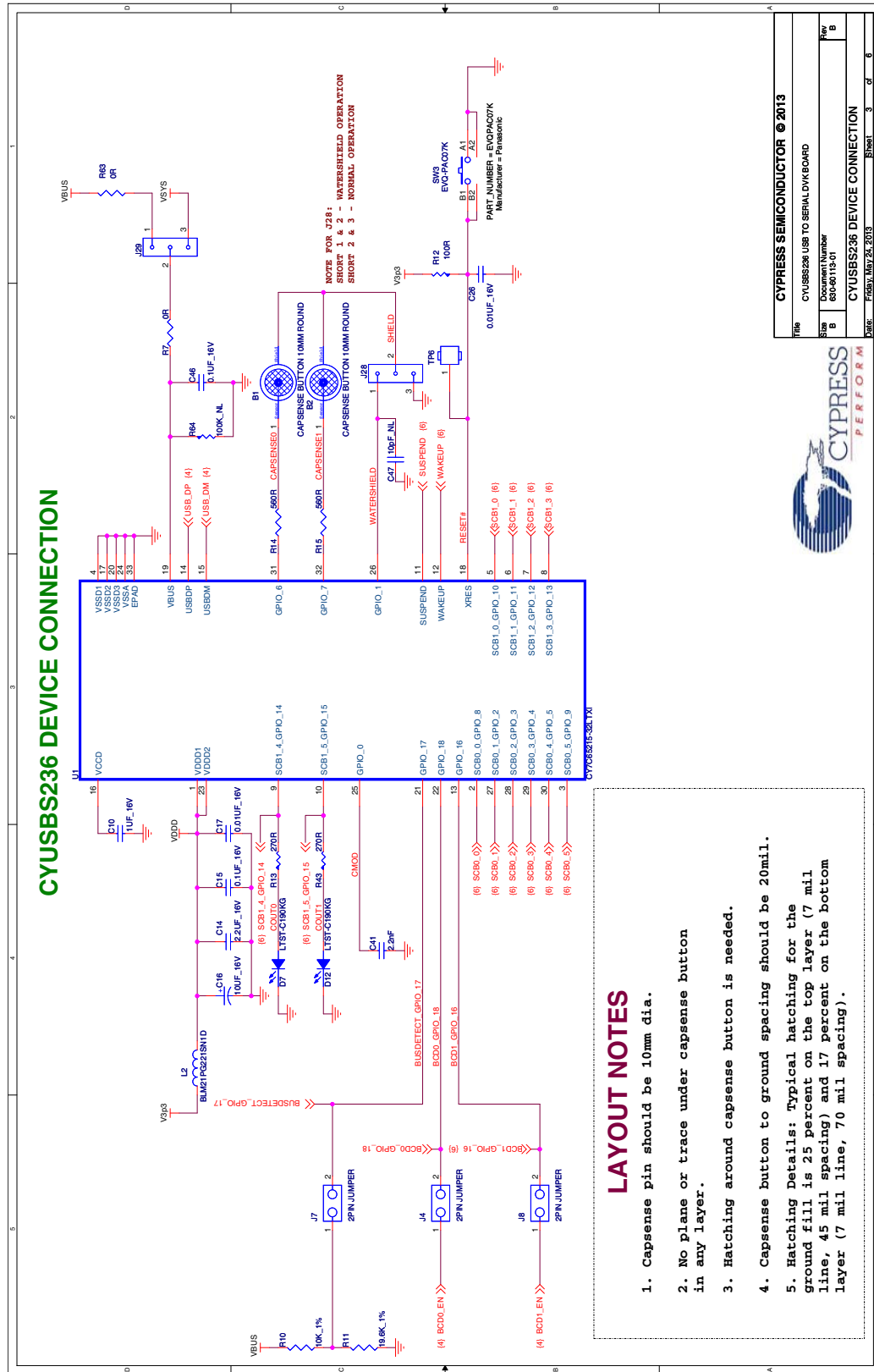

Figure A-2. Schematic



File	CYPRESS SEMICONDUCTOR © 2013
Doc Name	CYUSBS236 USB TO SERIAL DEV BOARD
Doc Number	806-0115-01
Rev	B
Date	Friday, May 24, 2013



Figure A-3. Schematic

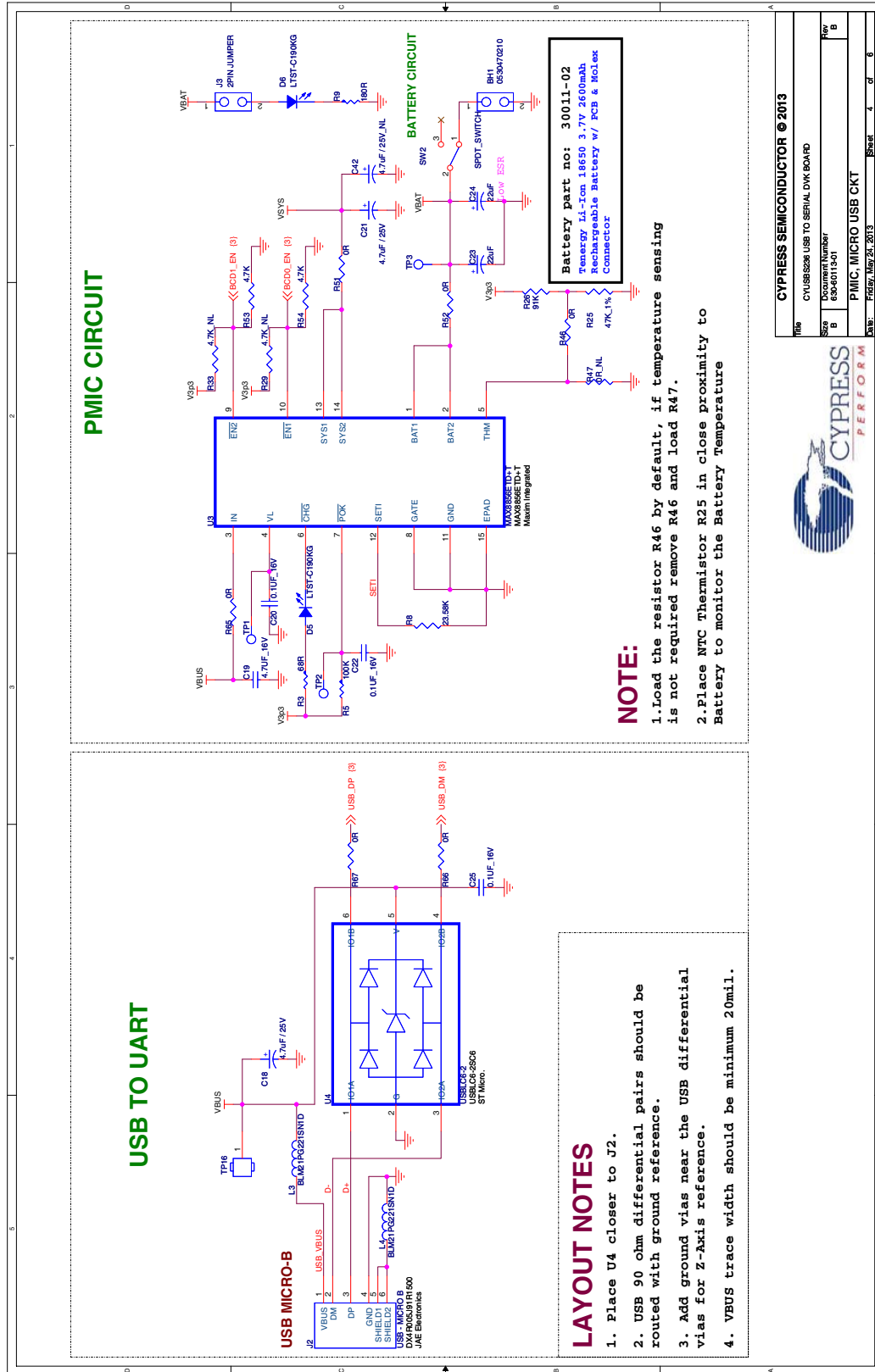
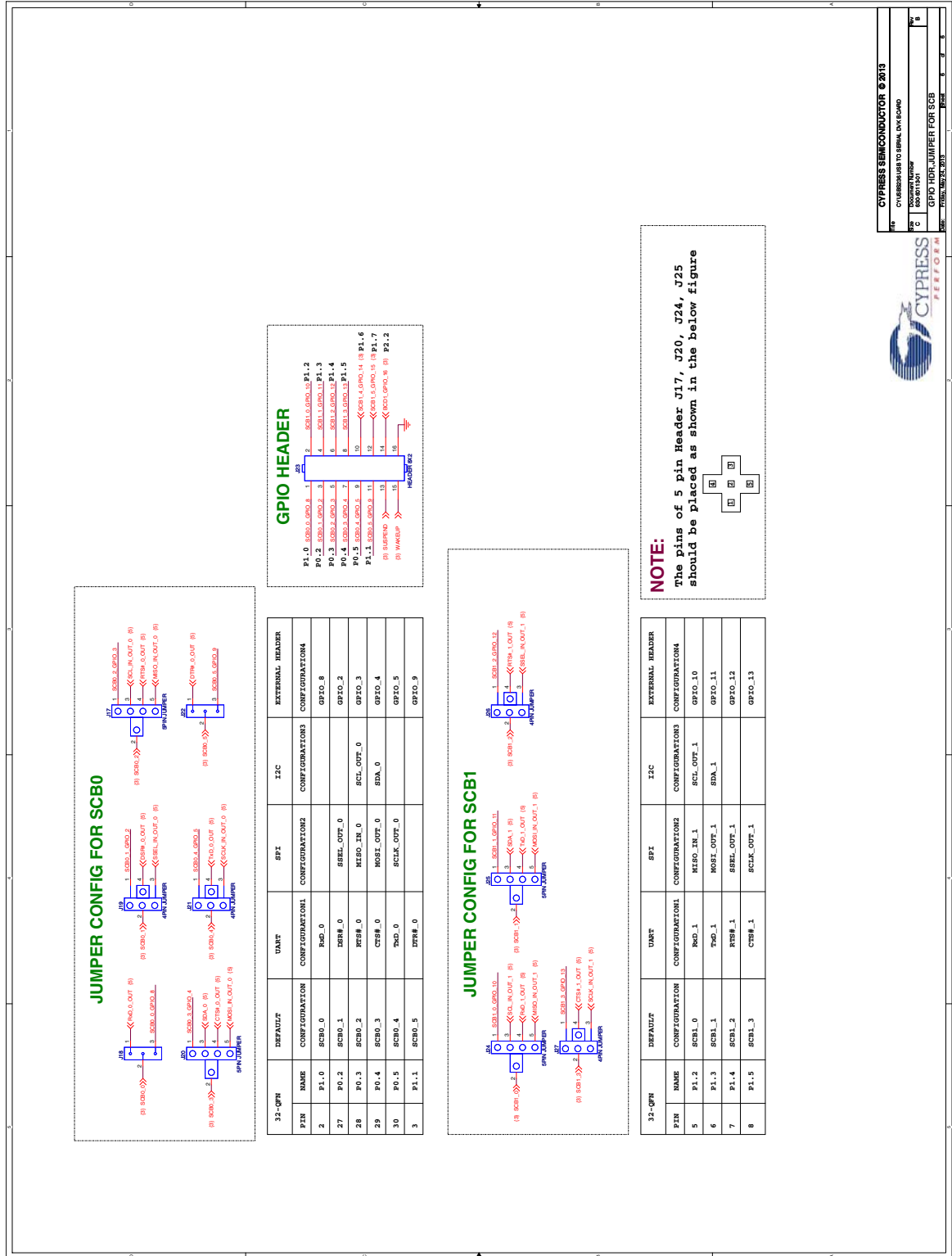

Figure A-5. Schematic



A.2 CY7C65215 USB-Serial Design Guidelines

This section explains the design guidelines for using the CY7C65215 USB-Serial bridge controller:

- The CY7C65215 silicon can operate from 1.71 V to 5.5 V.
- Short the VCCD pin to the VDDD pin when the operating voltage (VDDD) is from 1.71 V–1.89 V.
- Connect a 1- μ F decoupling capacitor between the VCCD pin and ground when the operating voltage is greater than 2 V.
- Place decoupling capacitors close to the VDDD pins. In this board, C14, C15, C16, and C17 are decoupling capacitors that are placed close to the VDDD pins. C10 is a 1- μ F capacitor, which is placed close to the VCCD pin, as shown in [Figure A-6](#).

Figure A-6. Decaps and CMOD Capacitor Placement

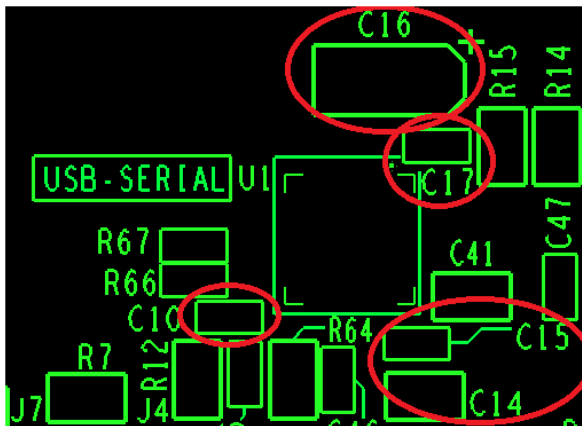

- The CY7C65215 USB-Serial bridge controller has an exposed pad (EPad) in the bottom that must be connected to the GND pad on the PCB.
- An active low 1- μ s pulse width is required to reset the CY7C65215 USB-Serial bridge controller.
- Do not provide pull-up resistors on SPI pins, except SSEL.
- Provide pull-up resistors on I2C pins.
- Route USB traces (DP/DM) with a 90- Ω impedance.
- Route USB differential traces (DP/DM) with solid reference plane.
- Place the ESD protection device closer to the USB connector.
- In the BCD interface, connect the bus-detect signal with a resistor divider network from VBUS. Refer to the *Application Examples* section in the CY7C65215 datasheet for recommended values.
- No plane or traces should be present under CapSense buttons in any layer.
- The CapSense pad should have 10-mm diameter.
- The CapSense button-to-ground spacing should be 20 mils.
- The typical hatching for the ground fill is 25 percent on the top layer (7-mil trace, 45-mil spacing) and 17 percent on the bottom layer (7-mil trace, 70-mil spacing).
- Ensure that the solder mask is enabled for CapSense pads.
- The CapSense trace and the water shield trace should be 7 mils in thickness.
- Route the CapSense trace in the gnd layer (inner layer) of the bottom layer, so that it is isolated from the external noise. On the top layer, because the traces are exposed, bringing a hand near the trace causes false triggers.
- The hatched GND should be extended along the full length of the CapSense trace routing.

- The CapSense trace should have a 560-ohms resistor that must be placed close to the silicon.
- The CMOD capacitor (2.2 nF) must be placed close to the silicon pin.
- The CMOD capacitor should be of Chip-On-Glass (COG) type.
- Make sure there is no test point or headers on the CapSense and CMOD traces.
- The gap between the ground and the sensor pad should be equal to the overlay thickness, but not less than 0.5 mm and not more than 2 mm.
- There must not be any solid ground around or beneath the sensor pad and sensor traces. Solid ground increases the sensor capacitance.
- The CapSense button shape should be a solid round pattern or a rectangle with curved edges.
- The button-to-button spacing must be 8 mm.
- The via hole size on the CapSense trace must be 10 mil. A maximum of 2 vias are allowed on the CapSense trace.

For more details, refer to [Getting Started with CapSense](#) at the Cypress website.

The following figures show the typical CapSense interface circuit and layout.

Figure A-7. CapSense Interface Circuit

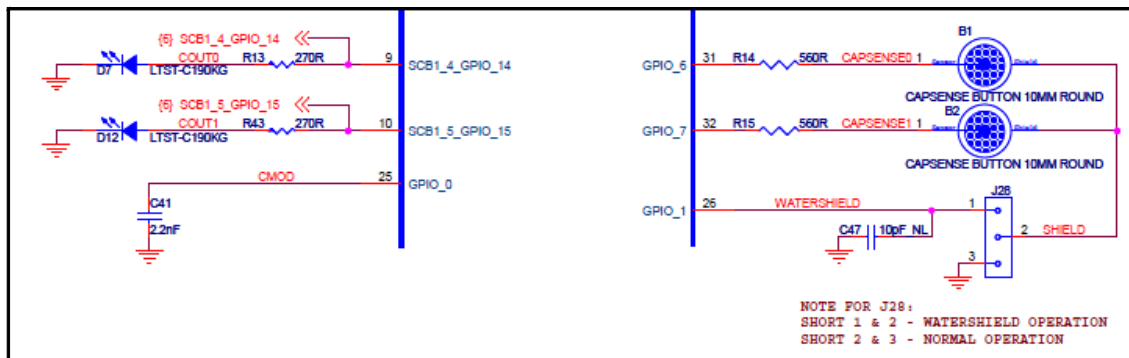

Figure A-8. CapSense Layout - Top Layer

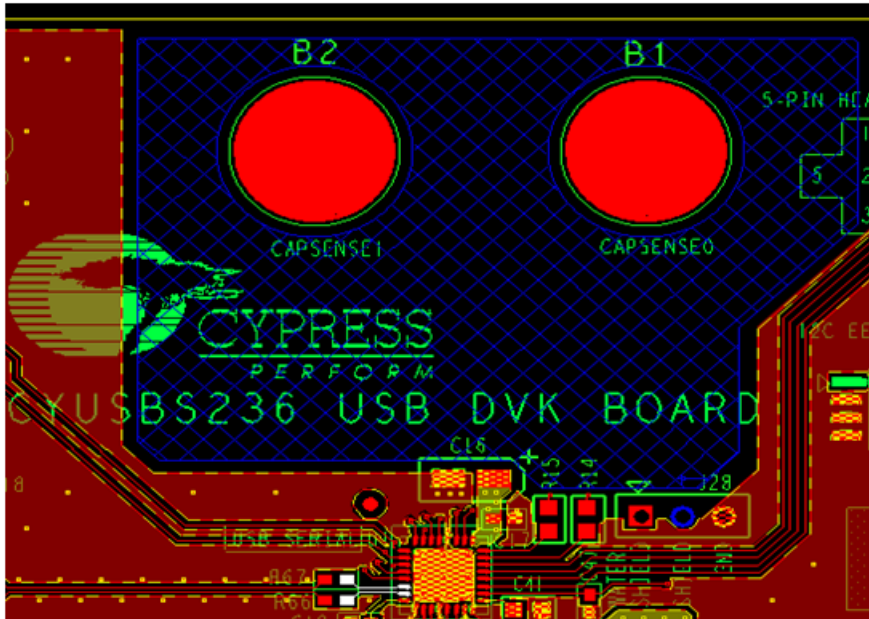

Figure A-9. CapSense Layout - Ground Layer

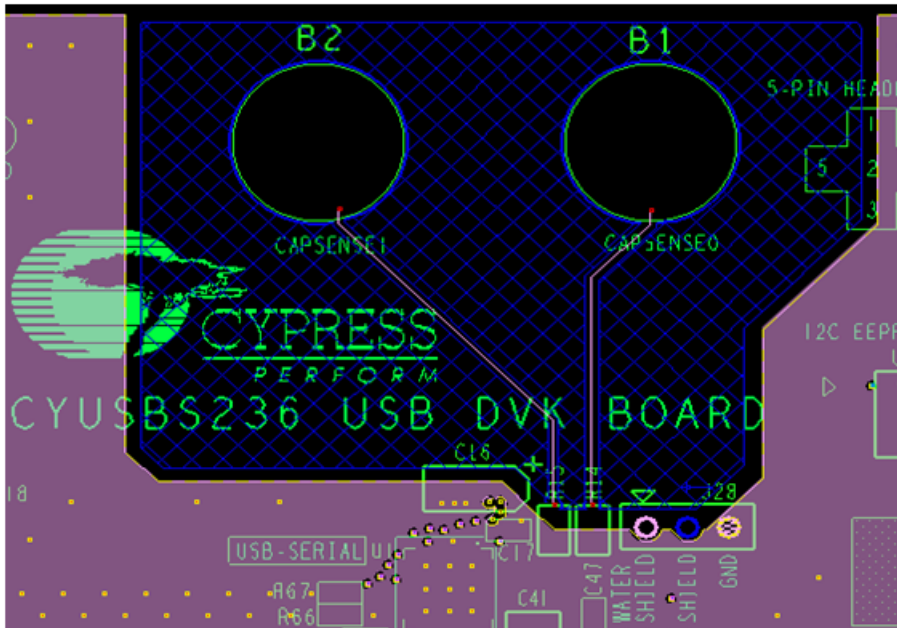

Figure A-10. CapSense Layout - Power Layer

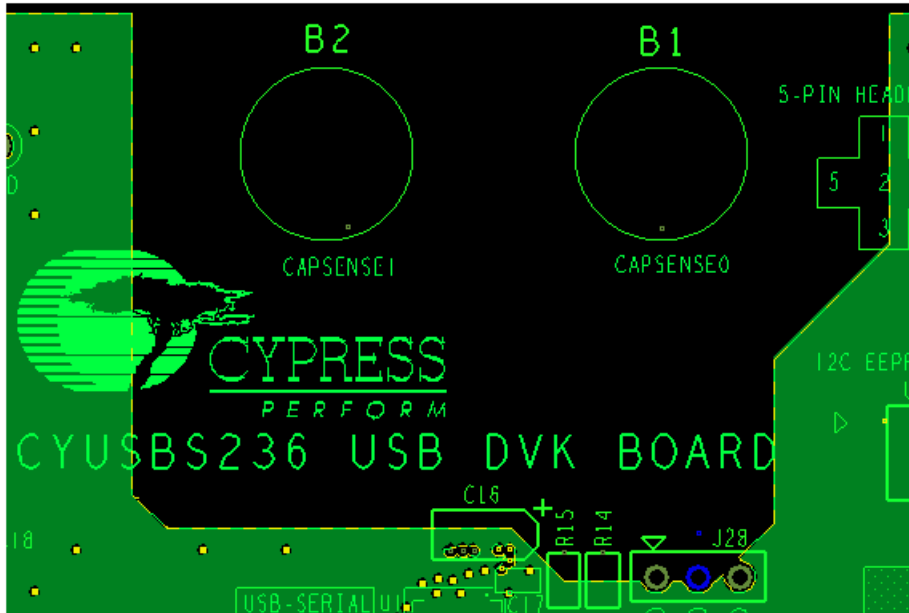

Figure A-11. CapSense Layout - Bottom Layer



A.3 Troubleshooting Guide

No.	Problem	Possible Cause	Possible Solution
1	CYUSBS236 USB DVK board does not power up in bus-powered mode. Power-on LEDs (D2 - 5 V, D4 - 3.3 V) do not light up	USB cable is not connected to PC	Connect the USB cable
		PC does not power up the USB port	Connect on a different USB port
		USB cable is faulty	Use a different USB cable or use self-powered mode and connect the 5-V DC power supply provided with the kit
		Power-on LED is faulty	Check the voltage on the D2 LED (TP19) is 5 V and the voltage on D4 LED (TP10) is 3.3 V
2	CYUSBS236 USB DVK board does not power up in self-powered mode. Power-on LEDs (D2 - 5 V, D4 - 3.3 V) do not light up	Power adapter is faulty	Check the voltage output from the power supply adapter. It should be approximately 5 V DC. If the power adapter is faulty, use the USB to power the board
		Power-on LED is faulty	Check the voltage on the D2 LED (TP19) is 5 V and the voltage on D4 LED (TP10) is 3.3 V
3	CYUSBS236 USB DVK board does not enumerate	USB driver is not bound to the DVK	Run <i>setup.exe</i> in following locations: <Install_directory>\Cypress\CYUSBS236 DVK\1.0\driver\cyusb3 <Install_directory>\Cypress\CYUSBS236 DVK\1.0\driver\cyusbserial
		Jumper J29 is not set	Set jumper J29 to 1-2. Set jumper J7 if the device is configured for BCD
4	SCB0 configured as UART does not work	One of these jumpers (J17, J18, J19, J20, J21, or J22) is not set correctly for UART configuration	Set the jumpers as mentioned in “ Test Procedure for CYUSBS236 DVK Configured as UART ” on page 28
		UART is not configured correctly	Load CYUSBS236 USB DVK.cyusb supplied with the kit. See “ CYUSBS236 DVK Restore Default Configuration Settings ” on page 62. Press the RESET switch to update the new configuration
5	SCB1 configured as UART does not work	One of these jumpers (J24, J25, J26, or J27) is not set correctly for UART configuration	Set the jumpers as mentioned in “ Test Procedure for CYUSBS236 DVK Configured as UART ” on page 28
		UART is not configured correctly	Load CYUSBS236 USB DVK.cyusb supplied with the kit. See “ CYUSBS236 DVK Restore Default Configuration Settings ” on page 62. Press the RESET switch to update the new configuration
6	SCB0 configured as I2C does not work	One of these jumpers (J17 or J20) is not set correctly for I2C configuration	Set the jumpers as mentioned in “ Test Procedure for CYUSBS236 DVK Configured as I2C ” on page 36
		I2C is not properly configured	Load CYUSBS236 i2c config.cyusb supplied with the kit. See “ CYUSBS236 DVK Restore Default Configuration Settings ” on page 62. Press the RESET switch to update the new configuration

No.	Problem	Possible Cause	Possible Solution
7	SCB1 configured as I2C does not work	One of these jumpers (J24 or J25) is not set correctly for I2C configuration	Set the jumpers as mentioned in “Test Procedure for CYUSBS236 DVK Configured as I2C” on page 36
		I2C is not configured correctly	Load CYUSBS236 i2c config.cyusb, supplied with the kit. See “CYUSBS236 DVK Restore Default Configuration Settings” on page 62 . Press the RESET switch to update the new configuration
8	SCB0 configured as SPI does not work	One of these jumpers (J17, J19, J20, or J21) is not set correctly for SPI configuration	Set the jumpers as mentioned in “Test Procedure for CYUSBS236 DVK Configured as SPI” on page 45
		SPI is not configured correctly	Load CYUSBS236 SPI_BCD.cyusb supplied with the kit. See “CYUSBS236 DVK Restore Default Configuration Settings” on page 62 . Press the RESET switch to update the new configuration
9	SCB1 configured as SPI does not work	One of these jumpers (J24, J25, J26, or J27) is not set correctly for SPI configuration	Set the jumpers as mentioned in “Test Procedure for CYUSBS236 DVK Configured as SPI” on page 45
		SPI is not configured correctly	Load CYUSBS236 SPI_BCD.cyusb supplied with the kit. See “CYUSBS236 DVK Restore Default Configuration Settings” on page 62 . Press the RESET switch to update the new configuration
10	CapSense buttons do not work	Jumper J28 is not set correctly for CapSense configuration	Set the jumper J28 in 2-3 for normal CapSense operation and in 1-2 for water proofing operation
		CapSense is not configured correctly	Load CYUSBS236 USB DVK.cyusb supplied with the kit. See “CYUSBS236 DVK Restore Default Configuration Settings” on page 62 . Press the RESET switch to update the new configuration
11	Battery charging does not work	One of these jumpers (J4, J7, or J8) is not set correctly for BCD configuration. Position of the SW2 is not correct	Set the jumpers as mentioned in “Test Procedure for CYUSBS236 DVK Configured for BCD” on page 60 . Set the SW2 to position 3
		Battery is dead	Replace the battery
		BCD is not configured correctly	Load CYUSBS236 SPI_BCD.cyusb supplied with the kit. See “CYUSBS236 DVK Restore Default Configuration Settings” on page 62 . Press the RESET switch to update the new configuration
12	Test utility is not working.(Test utility hangs after write data operation)	SPI or I2C Configuration jumpers are not set correctly.	Set the jumpers as mentioned in “Test Procedure for CYUSBS236 DVK Configured as SPI” on page 45 . Set the jumpers as mentioned in “Test Procedure for CYUSBS236 DVK Configured as I2C” on page 36 .

A.4 Bill of Materials (BOM)

Item	Qty	Reference	Description	Manufacturer	Mfr Part Number
1	1	600-60113-01 REV**	PCB, CYUSBS236 USB-Serial Board	Cypress Semiconductor	600-60113-01 REV**
2	1	BH1	CONN HEADER 2POS 1.25MM VERT TIN	Molex Inc	0530470210
3	1	C1	CAP ALUM 330UF 25V 20% SMD	Panasonic	EEE-1EA331UP
4	1	C2	CAP TANT 22UF 25V 20% 2917	Kemet	T496X226M025AT
5	2	C3,C16	CAP TANT 10UF 16V 20% 1206	AVX Corporation	TAJA106M016RNJ
6	1	C4	CAP TANT 100UF 10V 20% 1210	AVX Corporation	TAJB107M010RNJ
7	1	C7	CAP TANT 330UF 10V 10% 2917	AVX Corporation	TAJD337K010RNJ
8	3	C8,C9,C19	CAP CER 4.7UF 16V 10% X5R 0603	Taiyo Yuden	EMK107ABJ475KA-T
9	1	C10	CAP CER 1UF 16V 20% X5R 0402	TDK Corporation	C1005X5R1C105M
10	1	C14	CAP CER 2.2UF 16V 10% X5R 0603	TDK Corporation	C1608X5R1C225K/0.80
11	19	C15,C20,C22,C25,C27,C28,C29,C30,C31,C32,C33,C34,C35,C36,C37,C38,C39,C40,C46	CAP CER 0.1UF 16V 10% X7R 0402	Yageo	CC0402KRX7R7BB104
12	2	C17,C26	CAP CER 10000PF 16V 10% X7R 0402	Kemet	C0402C103K4RACTU
13	2	C18,C21	CAP TANT 4.7UF 25V 20% 1206	Kemet	T491A475M025AT
14	2	C23,C24	CAP CER 22UF 10V 10% X7R 1206	Murata	GRM31CR71A226KE15L
15	1	C41	CAP CER 2200PF 50V 5% NP0 0603	Murata Electronics North America	GRM1885C1H222JA01D
16	1	D1	DIODE SCHOTTKY 4A 40V SMB	Micro Commercial Co	SK44BL-TP
17	6	D2,D4,D5,D6,D7,D12	LED GREEN CLEAR 0603 SMD	Lite-On Inc	LTST-C190KGKT
18	4	D8,D9,D10,D11	LED GREEN RECT CLEAR 0603	Lite-On Inc	LTST-C193KGKT-5A
19	1	J1	CONN PWR JACK 2.1X5.5MM HIGH CUR	CUI Inc	PJ-102AH
20	1	J2	CONN RCPT 5POS R/A MICRO USB	JAE Electronics	DX4R005J91R1500
21	4	J3,J4,J7,J8	CONN HEADER 2POS .100" SNGL GOLD	Samtec Inc	TSW-102-08-G-S
22	2	J15,J16	CONN DB9 MALE .318" R/A NICKEL	Norcomp Inc	182-009-113R531
23	4	J17,J20,J24,J25	CONN HEADER 5POS .100" SNGL GOLD	Samtec Inc	TSW-105-08-G-S
24	4	J18,J22,J28,J29	CONN HEADER 3POS .100" SNGL GOLD	Samtec Inc	TSW-103-08-G-S
25	4	J19,J21,J26,J27	CONN HEADER 4POS .100" SNGL GOLD	Samtec Inc	TSW-104-08-G-S
26	1	J23	CONN HEADER 16POS .100" DL GOLD	Samtec Inc	TSW-108-08-G-D
27	3	L2,L3,L4	FERRITE CHIP 220 OHM 0805	Murata	BLM21PG221SN1D
28	2	R1,R9	RES 180 OHM 1/10W 5% 0603 SMD	Vishay Dale	CRCW0603180RJNEA
29	2	R2,R3	RES 68.0 OHM 1/8W 1% 0805 SMD	Panasonic	ERJ-6ENF68R0V
30	1	R5	RES 100K OHM 1/10W 5% 0603 SMD	Vishay/Dale	CRCW0603100KJNEA
31	11	R7,R44,R45,R46,R48,R49,R50,R51,R52,R63,R65	RES 0.0 OHM 1/10W 0603 SMD	Panasonic	ERJ-3GEY0R00V
32	1	R8	RES 23.7K OHM 1/10W 1% 0603 SMD	Panasonic	ERJ-3EKF2372V
33	1	R10	RES 10.0K OHM 1/10W 1% 0603 SMD	Panasonic	ERJ-3EKF1002V
34	1	R11	RES 19.6K OHM 1/10W 1% 0603 SMD	Panasonic	ERJ-3EKF1962V
35	1	R12	RES 100 OHM 1/8W 1% 0603 SMD	Stackpole Electronics Inc	RNCP0603FTD100R
36	6	R13,R16,R17,R18,R19,R43	RES 270 OHM 1/10W 5% 0603 SMD	Panasonic	ERJ-3GEYJ271V
37	2	R14,R15	RES 560 OHM 1/10W 1% 0603 SMD	Panasonic	ERJ-3EKF5600V
38	6	R20,R21,R22,R30,R31,R32	RES 10.0K OHM 1/10W 1% 0603 SMD	Panasonic	ERJ-3EKF1002V
39	4	R23,R24,R27,R28	RES 2.2K OHM 1/10W 5% 0603 SMD	Panasonic	ERJ-3GEYJ222V
40	1	R25	THERMISTOR NTC 47K 1% 0603	Vishay BC Components	NTCS0603E3473FHT
41	1	R26	RES 91.0K OHM 1/10W 1% 0603 SMD	Panasonic	ERJ-3EKF9102V

Item	Qty	Reference	Description	Manufacturer	Mfr Part Number
42	6	R53,R54,R55,R59,R57,R61	RES 4.70K OHM 1/10W 1% 0603 SMD	Panasonic	ERJ-3EKF4701V
43	2	R66,R67	RES 0.0 OHM 1/10W JUMP 0402 SMD	Panasonic	ERJ-2GE0R00X
44	2	SW1,SW2	SWITCH SLIDE MINI SPDT PCMNT SLV	C&K Components	1101M2S3CQE2
45	1	SW3	SWITCH TACTILE SPST-NO 0.02A 15V	Panasonic	EVQ-PAC07K
46	6	TP6,TP10,TP16,TP17,TP18,TP19	TEST POINT PC MINI .040"D RED	Keystone Electronics	5000
47	4	TP11,TP12,TP13,TP14	TEST POINT PC MINI .040"D Black	Keystone Electronics	5001
48	1	U1	USB-Serial Dual Channel UART/I2C/SPI bridge with CapSense and BCD	Cypress Semiconductor	CY7C65215-32LTXI
49	1	U2	IC REG LDO 3.3V 1A SOT-89-5	ON Semiconductor	NCP694H33HT1G
50	1	U3	IC BATT CHARGER LI+ 1CELL 14TDFN	Maxim Integrated	MAX8856ETD+T
51	1	U4	IC ESD PROTECTION LO CAP SOT23-6	STMicroelectronics	USBLC6-2SC6
52	2	U5,U6	IC TXRX RS232 1MBPS SD 28TSSOP	Maxim Integrated	MAX3245EEU+
53	2	U7,U9	IC EEPROM 128KBIT 400KHZ 8SOIC	Microchip Technology	24LC128-I/SM
54	2	U8,U10	IC EEPROM SPI BUS 2MB 8SOIC	STMicroelectronics	M95M02-DRMN6TP
No Load Components					
55	2	B1,B2			
56	1	C5	CAP TANT 100UF 10V 20% 1210	AVX Corporation	TAJB107M010RNJ
57	1	C6	CAP TANT 330UF 10V 10% 2917	AVX Corporation	TAJD337K010RNJ
58	1	C42	CAP TANT 4.7UF 25V 20% 1206	Kemet	T491A475M025AT
59	1	C43	CAP CER 2.2UF 16V 10% X5R 0603	TDK Corporation	C1608X5R1C225K/0.80
60	1	C44	CAP CER 0.1UF 16V 10% X7R 0402	Yageo	CC0402KRX7R7BB104
61	1	C45	CAP CER 10000PF 16V 10% X7R 0402	Kemet	C0402C103K4RACTU
62	1	C47	CAP CER 10PF 50V 10% NP0 0402	Kemet	C0402C100K5GACTU
63	6	R29,R33,R56,R58,R60,R62	RES 4.70K OHM 1/10W 1% 0603 SMD	Panasonic	ERJ-3EKF4701V
64	1	R47	RES 0.0 OHM 1/10W 0603 SMD	Panasonic	ERJ-3GEY0R00V
65	1	R64	RES 100K OHM 1/10W 5% 0603 SMD	Vishay/Dale	CRCW0603100KJNEA
66	7	TP1,TP2,TP3,TP7,TP8,TP9,TP15			



Компания «ЭлектроПласт» предлагает заключение долгосрочных отношений при поставках импортных электронных компонентов на взаимовыгодных условиях!

Наши преимущества:

- Оперативные поставки широкого спектра электронных компонентов отечественного и импортного производства напрямую от производителей и с крупнейших мировых складов;
- Поставка более 17-ти миллионов наименований электронных компонентов;
- Поставка сложных, дефицитных, либо снятых с производства позиций;
- Оперативные сроки поставки под заказ (от 5 рабочих дней);
- Экспресс доставка в любую точку России;
- Техническая поддержка проекта, помощь в подборе аналогов, поставка прототипов;
- Система менеджмента качества сертифицирована по Международному стандарту ISO 9001;
- Лицензия ФСБ на осуществление работ с использованием сведений, составляющих государственную тайну;
- Поставка специализированных компонентов (Xilinx, Altera, Analog Devices, Intersil, Interpoint, Microsemi, Aeroflex, Peregrine, Syfer, Eurofarad, Texas Instrument, Miteq, Cobham, E2V, MA-COM, Hittite, Mini-Circuits, General Dynamics и др.);

Помимо этого, одним из направлений компании «ЭлектроПласт» является направление «Источники питания». Мы предлагаем Вам помощь Конструкторского отдела:

- Подбор оптимального решения, техническое обоснование при выборе компонента;
- Подбор аналогов;
- Консультации по применению компонента;
- Поставка образцов и прототипов;
- Техническая поддержка проекта;
- Защита от снятия компонента с производства.



Как с нами связаться

Телефон: 8 (812) 309 58 32 (многоканальный)

Факс: 8 (812) 320-02-42

Электронная почта: org@eplast1.ru

Адрес: 198099, г. Санкт-Петербург, ул. Калинина, дом 2, корпус 4, литера А.