

Factory Line Accessories

FL PLUG RJ 45 ...

FL CRIMPTOOL

1. Description

FL PLUG RJ 45 ... connectors and the corresponding FL CRIMPTOOL crimping pliers are available for field terminations of RJ45 connectors.

The shielded FL PLUG RJ45... connector enables the easy connection of an Ethernet cable. It can be connected to solid or flexible individual wires in a variety of ways. It is thus possible to assemble either patch cables or permanently installed field cables with just one connector.

Due to the high-quality shield connection and reduced crosstalk, the connector meets requirements of CAT 5+ (up to 125 MHz).

The connector set (2 connectors) with the gray bending protection bushing is designed for uncrossed connections. The connector set with the green bending protection bushing is designed for crossed connections.

The high-quality FL CRIMPTOOL crimping pliers are used to safely prepare FL PLUG RJ45... RJ45 connectors from Phoenix Contact.

The replaceable crimping cutter enables the pliers to be quickly adapted to various requirements. A wide selection of crimping cutters is available for various uses, from ferrules through to complex connector inserts.

Another special feature is the linear action crimping principle. The crimping profiles move together in a highly precise linear movement. In this way, the crimping contacts are formed in parallel and are therefore completely symmetrical. The result is perfect connections. The FL CRIMPTOOL is fitted with a control lock. This releases when the required molding pressure is reached, therefore ensuring sufficient pressure is applied during crimping.



Should you have any technical questions, please contact us:

PSM HOTLINE: +49 - 52 35 - 31 98 90

FAX: +49 - 52 35 - 31 98 99

E-mail: interface-service@phoenixcontact.com

2. Technical Data



FL PLUG RJ45 FL CRIMPTOOL

Description	Type	Order No.	Pcs. Pkt.
RJ45 connector , shielded, with bending protection bushing, 2 pieces <ul style="list-style-type: none"> • Gray for straight cable • Green for crossover cable 	FL PLUG RJ45 GR/2 FL PLUG RJ45 GN/2	27 44 85 6 27 44 57 1	1 1
Crimping pliers , for assembling the RJ45 connectors	FL CRIMPTOOL	27 44 86 9	1
Stripping tool	CYCLOPS	12 04 48 1	1
Stripping knife	Kames optical fiber	12 06 14 6	1
Technical Data			
FL PLUG RJ 45... Connection options including insulation Connector cycles Contact material Insulating material Flammability class in accordance with UL 94 Temperature Dimensions Approvals	1 mm (0.039 in.) individual wire 5.4 mm (0.213 in.) entire cable > 2500 with Factory Line devices Phosphor bronze with 50 µm gold coating Polycarbonate V0 -40°C to +85°C (-40°F to +185°F) 12 mm x 27 mm x 7.5 mm (0.472 in. x 1.063 in. x 0.295 in.) UL File E132408(N)-DUXR2, CSA File 67725		
FL CRIMPTOOL Dimensions	220 mm x 75 mm x 32 mm (8.661 in. x 2.953 in. x 1.260 in.)		

3. Assembly Instructions for ETHERNET Cable With RJ45 Connector

 If the double sheathed Ethernet cable type "FL CAT5 HEAVY..." is not used, omit the first configuration step and start with the second step.

3.1. Removing the Double Sheath

- Cut at least 10 cm (3.937 in.) along the cable towards the end using a suitable stripping knife (e.g., "KAMES LWL"; Order No. 12 06 14 6).
- Twist the tearing wire around a supporting tool (e.g., screwdriver, pliers) and make sure it is secure. Now tear open the double sheath to the desired length.
- Use a sharp diagonal cutter to cut off the sheath and the tearing wire without damaging the inner sheath.

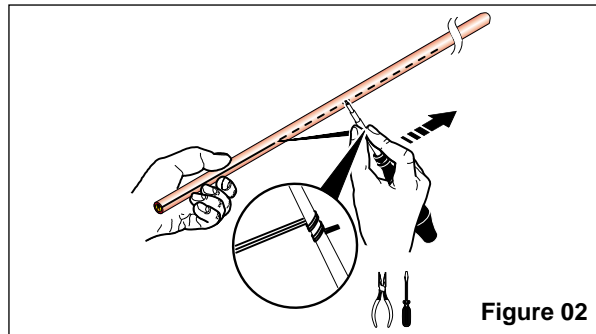
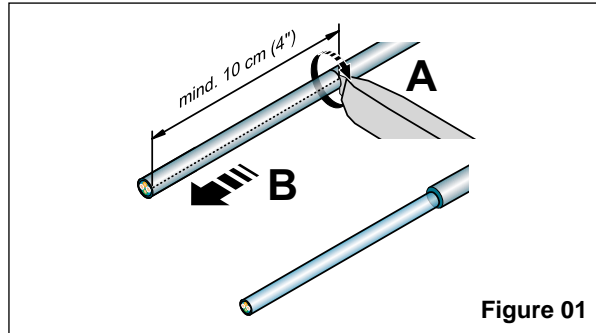

3.2. Pushing on the Protective Cap

Push the protective cap onto the cable as illustrated.

Observe the colors for the corresponding application:

- Gray for line cables
- Green for crossover cables.

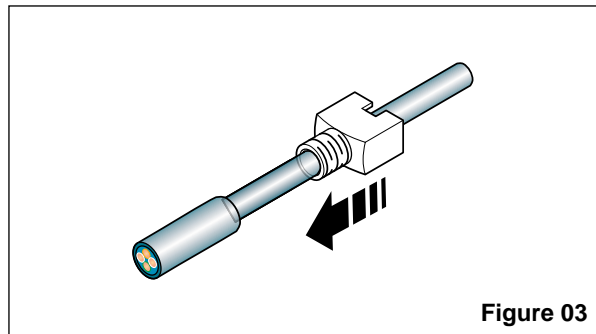

3.3. Stripping the Cable and Bending Back the Braided Shield

Remove 40 mm (1.575") of the sheath using a suitable stripping knife (e.g., "CYCLOPS", Order No. 12 04 48 1) (A).

Bend the braided shield back around the cable. The shielding should cover the cable as closely as possible (B).

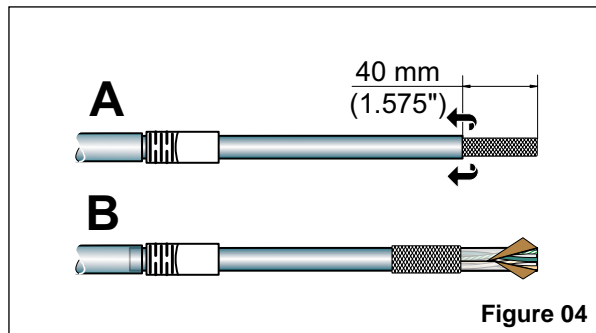

3.4. Removing the Protective Foil

Spread the foil along the overlap (A). Bend the foil upwards and then tear it off (B).

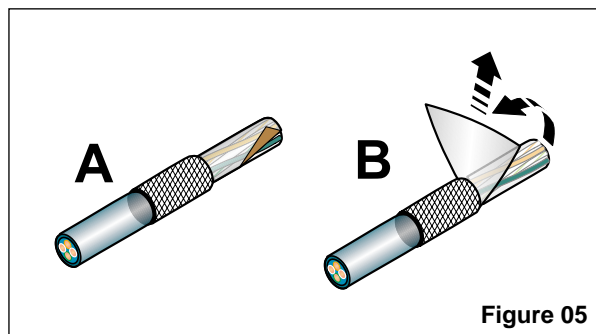

3.5. Removing the Protective Foil

Cut off the transparent protective foil as short as possible, e.g., with a diagonal cutter.

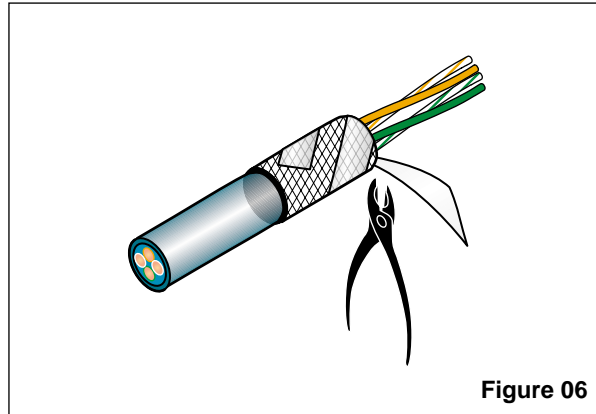



Figure 06

3.6. Pushing on the Shield Ring

Push the shield ring over the braided shield and protective foil.

 **Keep the rounded side of the shield ring facing towards the individual wires.**

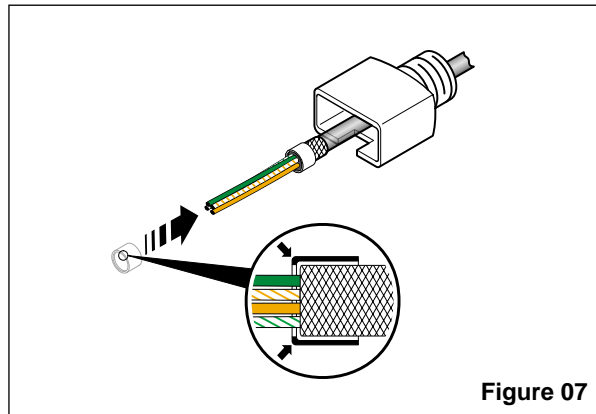

Figure 07

3.7. Pressing the Shield Ring

Press the shield ring using the "FL CRIMPTOOL" pliers (Order No. 27 44 86 9).

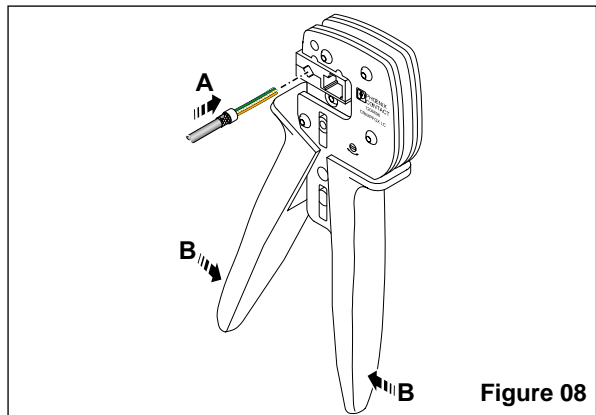

Figure 08

3.8. Cutting off the Braided Shield

Cut off the protruding braided shield cleanly (1).

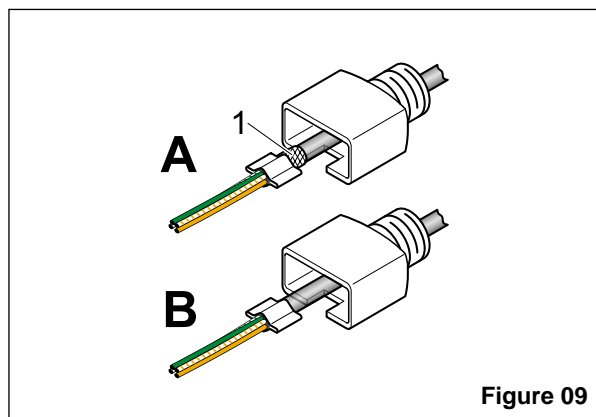

Figure 09

3.9. Cutting off the Cables at an Angle

Cut off the cables at an angle of approximately 45°.

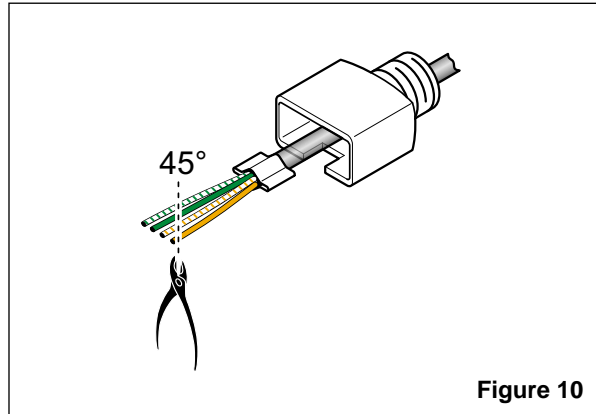

Figure 10

3.10. Wiring the Cables in the Management Bar

Wire up the cables in the management bar.

Observe the assignment for the various cable types (see Sections 3.11 and 3.12).

3.10.1. Connection Between the Network Components

- Line 1:1 = gray protective caps
- Crossover = green protective caps

	PC/RFC	IBS gateway	I/O bus terminal module	Switch	Hub	Medium converter
PC/RFC	Cross	Cross	Cross	Line	Line	Line
IBS gateway	Cross	Cross	Cross	Line	Line	Line
I/O bus terminal	Cross	Cross	Cross	Line	Line	Line
Switch	Line	Line	Line	Cross	Cross	Cross
Hub	Line	Line	Line	Cross	Cross	Cross
Medium converter	Line	Line	Line	Cross	Cross	Cross

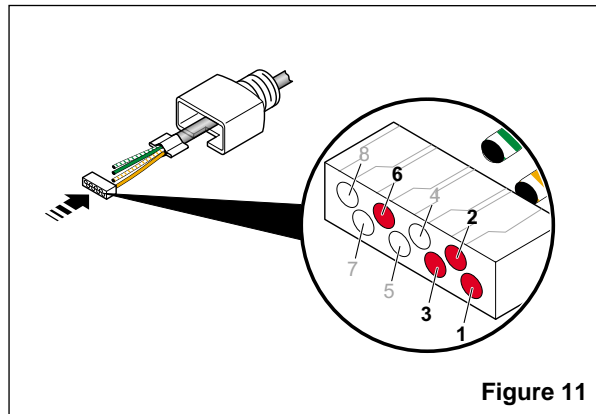

Figure 11

3.11. Line Cable (1:1) (Gray Protective Caps)

For connecting active network components to terminal devices (e.g., from the hub to the PC)

Cable assembly:

(1)	Green	(1)
(2)	Green/white	(2)
(3)	Orange	(3)
(6)	Orange/white	(6)

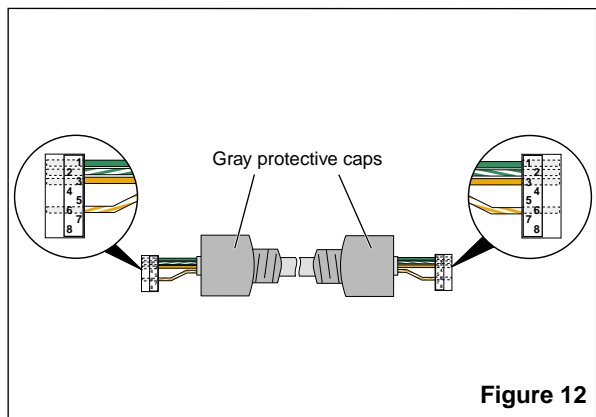

Figure 12

3.12. Crossover Cable (Green Protective Caps)

For connecting active network components (e.g., hubs, switches, medium converters, etc.)

Cable assembly:

(1)	Green	(3)
(2)	Green/white	(6)
(3)	Orange	(1)
(6)	Orange/white	(2)

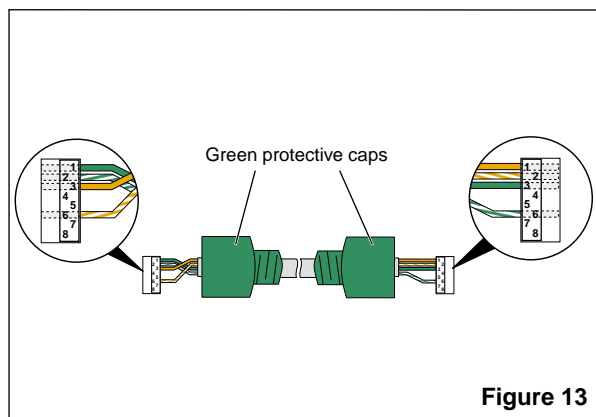

Figure 13

3.13. Cutting off the Cables

Cut off the cables at a right angle to a maximum total length of 14 mm (0.551").

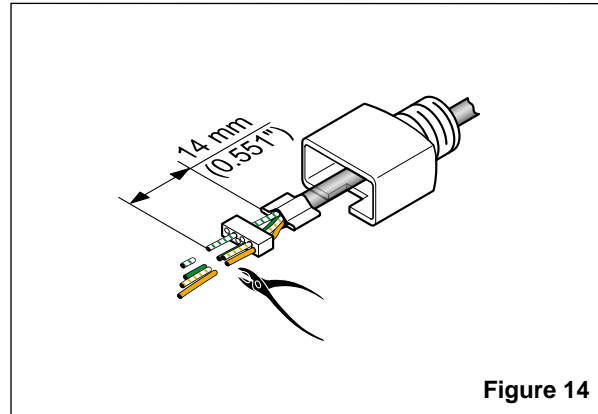

Figure 14

3.14. Inserting the Management Bar in the Connector

Pull back the management bar until it reaches the cable ends. Then insert the cable with the management bar into the connector from behind.

From the front side of the connector, ensure that all of the cables are in the correct position and are completely under the crimping contacts.

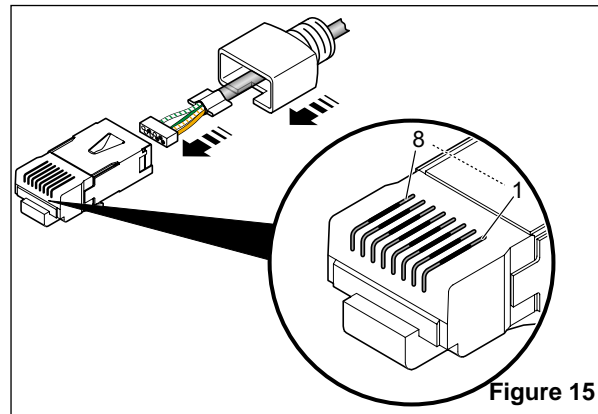

Figure 15

3.15. Crimping the Connector

Insert the connector in the open pliers.

Ensure that the connector is locked in the pliers (A).

Crimp the connector (B).

The crimping process is complete when the hand grips automatically spring back into their original position.

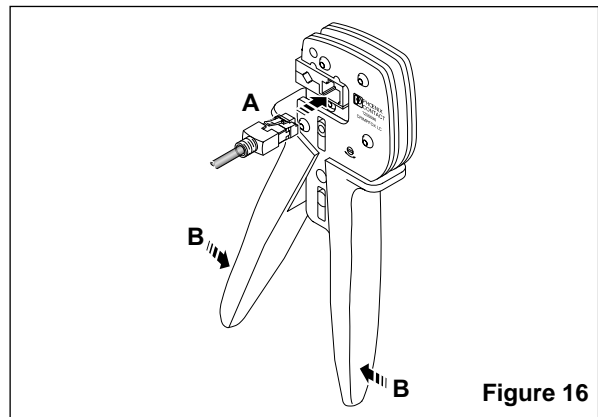

Figure 16



Компания «ЭлектроПласт» предлагает заключение долгосрочных отношений при поставках импортных электронных компонентов на взаимовыгодных условиях!

Наши преимущества:

- Оперативные поставки широкого спектра электронных компонентов отечественного и импортного производства напрямую от производителей и с крупнейших мировых складов;
- Поставка более 17-ти миллионов наименований электронных компонентов;
- Поставка сложных, дефицитных, либо снятых с производства позиций;
- Оперативные сроки поставки под заказ (от 5 рабочих дней);
- Экспресс доставка в любую точку России;
- Техническая поддержка проекта, помощь в подборе аналогов, поставка прототипов;
- Система менеджмента качества сертифицирована по Международному стандарту ISO 9001;
- Лицензия ФСБ на осуществление работ с использованием сведений, составляющих государственную тайну;
- Поставка специализированных компонентов (Xilinx, Altera, Analog Devices, Intersil, Interpoint, Microsemi, Aeroflex, Peregrine, Syfer, Eurofarad, Texas Instrument, Miteq, Cobham, E2V, MA-COM, Hittite, Mini-Circuits, General Dynamics и др.);

Помимо этого, одним из направлений компании «ЭлектроПласт» является направление «Источники питания». Мы предлагаем Вам помощь Конструкторского отдела:

- Подбор оптимального решения, техническое обоснование при выборе компонента;
- Подбор аналогов;
- Консультации по применению компонента;
- Поставка образцов и прототипов;
- Техническая поддержка проекта;
- Защита от снятия компонента с производства.

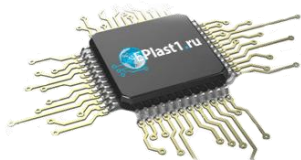

Как с нами связаться

Телефон: 8 (812) 309 58 32 (многоканальный)

Факс: 8 (812) 320-02-42

Электронная почта: org@eplast1.ru

Адрес: 198099, г. Санкт-Петербург, ул. Калинина, дом 2, корпус 4, литера А.