

3.3V Precision Audio Clock Synthesizer

Features

- Precision clock generator for digital audio application
- One copy of Reference clock at 27 MHz
- Supports various audio sampling rates: 128x, 256x, 384x, 512x and 768x
- Support Crystal or Reference clock signal input
- Low Phase Noise: -75 dBc @ 100Hz
- Low Short Term Jitter: 175ps (typical)
- Low Long Term Jitter: 1.1ns (typical)
- Industrial Temperature Range (-40°C ~ +85°C)
- Packaging (Pb-Free & Green):
—16-pin TSSOP

Description

The PI6C6612 is a precision clock generator designed to provide synchronous clock signals for digital audio applications with sampling clock rates derived from an MPEG stream. The device can also be used as a standalone clock source with a 27 MHz crystal.

Split power supply pins and ground pins help to provide excellent phase noise and long term jitter performance for superior synchronization and Signal-to-Noise ratio.

PI6C6612 is one example of Pericom's multimedia clock products, if you have other applications for custom clock designs, either with different clock input or output that is not specified here, please contact Pericom.

Block Diagram

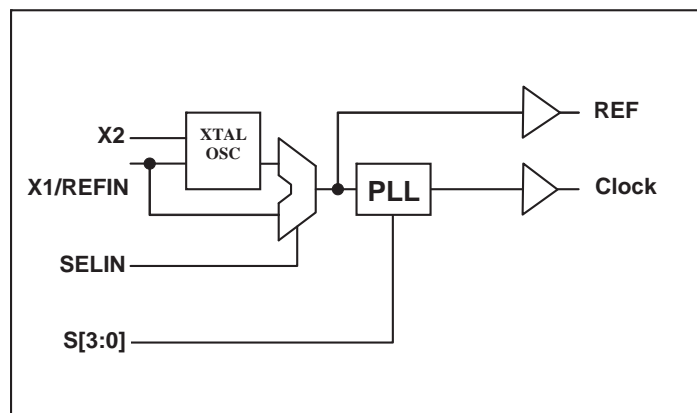

Output Clock Selection Table from 27 MHz input

S3	S2	S1	S0	Clock (MHz)
0	0	0	0	8.192
0	0	0	1	11.2896
0	0	1	0	12.288
0	0	1	1	24.576
0	1	0	0	9.216
0	1	0	1	16.9344
0	1	1	0	18.432
0	1	1	1	36.864
1	0	0	0	16.384
1	0	0	1	22.5792
1	0	1	0	5.6448
1	0	1	1	49.152
1	1	0	0	6.1440
1	1	0	1	33.8688
1	1	1	0	8.4672
1	1	1	1	73.728

Pin Assignment

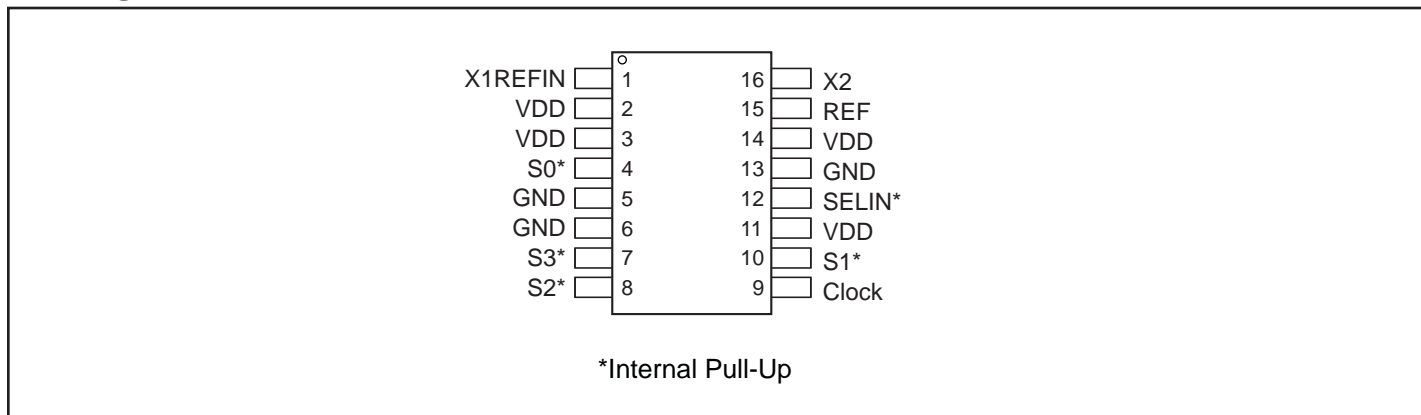

Pin Description

Pin Name	Pin No	I/O Type	Pin Description
X1/REF _{IN}	1	I	Crystal or Reference clock input. See "Recommended Crystal Specifications" for details.
V _{DD}	2, 3, 11, 14	Power	Power supply
S ₀ *	4	I	Output clock selection
GND	5, 6, 13	Ground	Ground
S ₃ *	7	I	Output clock selection
S ₂ *	8	I	Output clock selection
Clock	9	O	Clock output
S ₁ *	10	I	Output clock selection
SELIN*	12	I	Input clock selection. Low: reference clock input; High: crystal clock input
REF	15	O	Reference clock input
X ₂	16	I	Crystal clock input; leave open if SELIN=Low

* Internally Pulled High

Electrical Specifications

Maximum Ratings

Item	Rating
Supply Voltage to Ground Potential	5.5V
All Inputs and Outputs	-0.5 to V _{DD} +0.5V
Ambient Operating Temperature	-40 to +85°C
Storage Temperature	-65 to +150°C
Junction Temperature	150°C
Soldering Temperature	260°C

Note: Beyond maximum ratings may cause device damage

Recommended Operation Conditions

Parameter	Min.	Typ.	Max.	Unit
Ambient Operating Temperature	-40		+85	°C
Power Supply Voltage (measured in respect to GND)	+3.0		+3.6	V

DC Electrical Characteristics

V_{DD} = 3.3V ±10%, Ambient Temperature -40 to +85°C

Symbol	Parameter	Conditions	Min.	Typ.	Max.	Unit
V _{DD}	Operating Voltage		3.0		3.6	V
V _{IH}	Input High Voltage		2			V
V _{IL}	Input Low Voltage				0.8	V
V _{OH}	Output High Voltage	I _{OH} = -4mA	V _{DD} -0.4			V
V _{OH}	Output High Voltage	I _{OH} = -12mA	2.4			V
V _{OL}	Output Low Voltage	I _{OL} = +12mA			0.4	V
I _{DD}	Supply Current	No Load		25		mA
I _{OS}	Short Circuit Current	Each output		±65		mA
Z _{OUT}	Nominal Output Impedance			20		Ω
Z _{IN}	Input Capacitance	Input pins		7		pF
R _{Pullup}	Internal pull-up resistor			120		KΩ

AC Electrical Characteristics

V_{DD} = 3.3V ±10%, Ambient Temperature -40 to +85°C

Symbol	Parameter	Conditions	Min.	Typ.	Max.	Unit
F _{cry}	Crystal Frequency			27	28	MHz
t _{Rise}	Output Clock Rise Time	20% to 80%, 15pF load			1.5	ns
t _{Fall}	Output Clock Fall Time	80% to 20%, 15pF load			1.5	ns
t _{DC}	Output Duty Cycle	Measured at V _{DD} /2, 15pF load	45	50	55	%

T _{j_short}	Short term jitter	Reference clock off		175		ps p-p
T _{j_short}	Short term jitter	Reference clock on		175		ps p-p
T _{j_long}	Long term jitter	Reference clock off; 10 μ delay		1100		ps p-p
T _{j_long}	Long term jitter	Reference clock on; 10 μ delay		1100		ps p-p
Phase Noise	Single sideband phase noise	33 MHz; 10Hz offset		-50		dBc
Phase Noise	Single sideband phase noise	33 MHz; 100Hz offset		-75		dBc
Phase Noise	Single sideband phase noise	33 MHz; 1kHz offset		-80		dBc
Phase Noise	Single sideband phase noise	33 MHz; 10kHz offset		-75		dBc
FERROR	Actual mean frequency error versus target			0		ppm

Thermal Characteristics

Symbol	Parameter	Conditions	Min.	Typ.	Max.	Unit
θJA	Thermal Resistance Junction to Ambient	Still air		78		°C/W
θJA		1 min m/s air flow		70		°C/W
θJA		3 min m/s air flow		68		°C/W
θJC	Thermal Resistance Junction to Case			37		°C/W

Recommended Crystal Specification

Pericom's 49SMLB27.0000 MHz parallel resonance crystal is recommended.

Recommended Crystal Specification

Parameter	Value	Units
Mode of oscillation	Fundamental AT	
Frequency	27	MHz
Frequency Tolerance	±50	PPM
Temperature and aging stability	±50	PPM
C0/C1 ratio	240	
Load cap	18	pF
Equivalent series resistance	30	Ω

Packaging Mechanical: 16-pin TSSOP (L16)

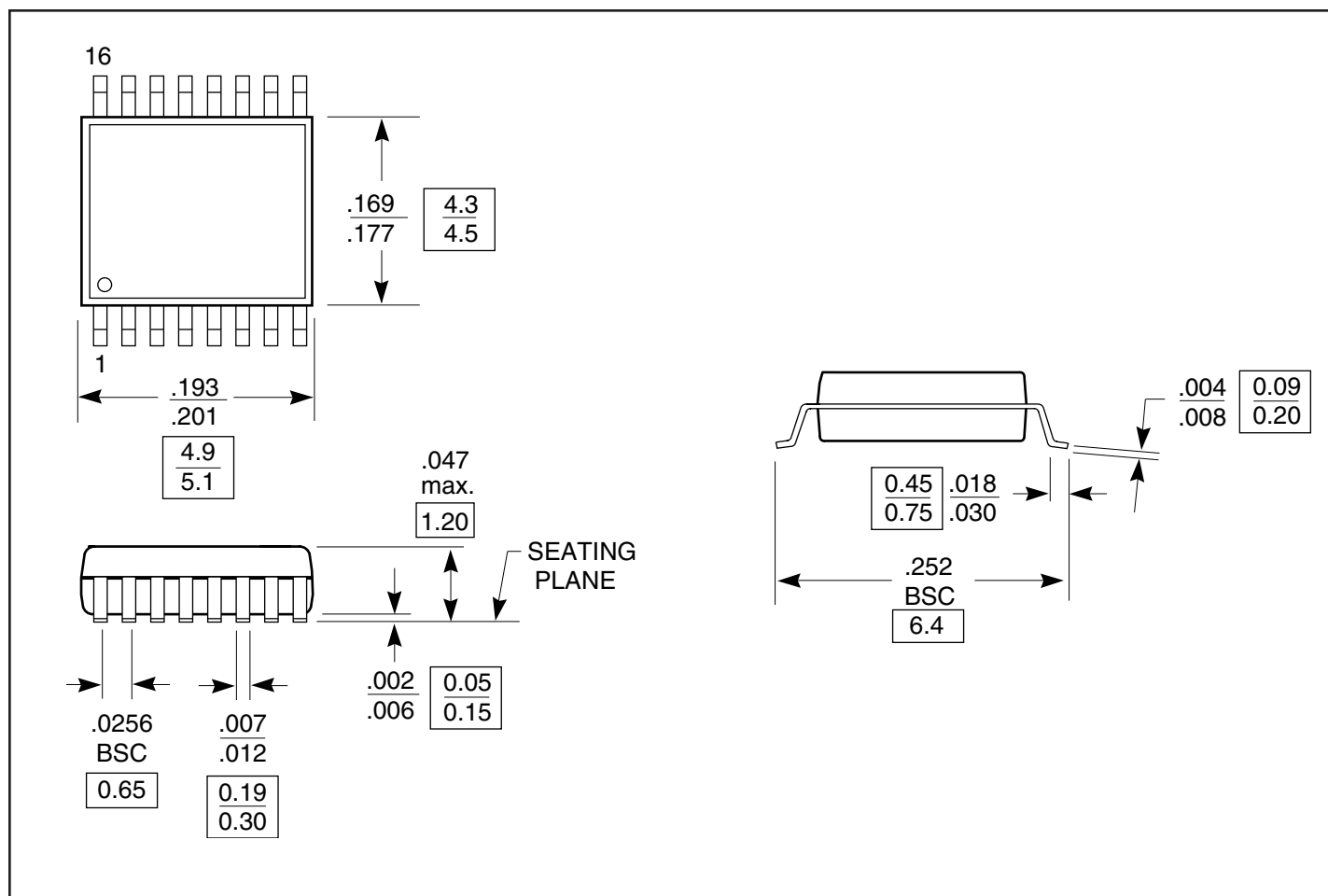

Ordering Information

Ordering Code	Package Code	Package Type	Operating Range
PI6C6612LE	L	Pb-free & Green 16-pin TSSOP	Industrial



Компания «ЭлектроПласт» предлагает заключение долгосрочных отношений при поставках импортных электронных компонентов на взаимовыгодных условиях!

Наши преимущества:

- Оперативные поставки широкого спектра электронных компонентов отечественного и импортного производства напрямую от производителей и с крупнейших мировых складов;
- Поставка более 17-ти миллионов наименований электронных компонентов;
- Поставка сложных, дефицитных, либо снятых с производства позиций;
- Оперативные сроки поставки под заказ (от 5 рабочих дней);
- Экспресс доставка в любую точку России;
- Техническая поддержка проекта, помощь в подборе аналогов, поставка прототипов;
- Система менеджмента качества сертифицирована по Международному стандарту ISO 9001;
- Лицензия ФСБ на осуществление работ с использованием сведений, составляющих государственную тайну;
- Поставка специализированных компонентов (Xilinx, Altera, Analog Devices, Intersil, Interpoint, Microsemi, Aeroflex, Peregrine, Syfer, Eurofarad, Texas Instrument, Miteq, Cobham, E2V, MA-COM, Hittite, Mini-Circuits, General Dynamics и др.);

Помимо этого, одним из направлений компании «ЭлектроПласт» является направление «Источники питания». Мы предлагаем Вам помощь Конструкторского отдела:

- Подбор оптимального решения, техническое обоснование при выборе компонента;
- Подбор аналогов;
- Консультации по применению компонента;
- Поставка образцов и прототипов;
- Техническая поддержка проекта;
- Защита от снятия компонента с производства.



Как с нами связаться

Телефон: 8 (812) 309 58 32 (многоканальный)

Факс: 8 (812) 320-02-42

Электронная почта: org@eplast1.ru

Адрес: 198099, г. Санкт-Петербург, ул. Калинина, дом 2, корпус 4, литера А.