

1500-FAN-01

Instruction Manual

FAN REPLACEMENT

This equipment uses a fan for cooling purposes. However, fan has a short life span and should be replaced periodically.

Please contact our company for fan replacement and it is at customer expenses. The diagram in 1.Fan Life span Expectancy section is a simple time guideline for fan replacement.

Please contact our sales office between 3 to 6 months prior to fan replacement.

Please be aware that fan replacement perform by customer compromises product safety standard (UL,CE etc.) and voids product warranty. Equipment's inlet and outlet could be blocked by dust if fan replacement is neglected. This will result in damaging the product, interfering with the cooling system and cause over heating.

It is advisable to always keep the equipment's inlet and outlet clean and replace the fan when the time comes.

This fan motor uses a precise ball bearing. Please avoid from dropping, applying shock to the fan as it will have a negative (unusual sound, life span decrease) effect to the fan motor.

Please avoid dropping or chucking the fan even in wrapping condition as it will also have a negative effect.

BEFORE USING THE POWER SUPPLY UNIT

Be sure to read this instruction manual thoroughly before using this product. Pay attention to all cautions and warnings before using this product. Incorrect usage could lead to an electrical shock, damage to the unit or a fire hazard.

⚠ DANGER

- Never use this unit in places with flammable gas or ignitable substances. There are risks of igniting these substances and exploding by an arcing.

⚠ WARNING

- Do not make unauthorised changes to power supply unit, otherwise you may have electric shock and void your warranty.
- Do not touch this unit and the internal components in operation or shortly after shut down. They may have high voltage or high temperature and as the unit dissipates its heat so the surface of the unit is hot. You may receive electric shock or burn.
- When the unit is operating, keep your hands and face away from it; you may be injured by an accident
- Do not use unit under unusual condition such as emission of smoke or abnormal smell and sound etc. It might cause fire and electric shock. In such case, please contact us; do not repair by yourself, as it is dangerous for the user.
- Do not drop or insert anything into unit. It might cause failure and fire.
- Do not operate these units under condensation condition. It may cause fire and electric shock.

⚠ CAUTION

- This power supply is primarily designed and manufactured to be used and enclosed in other equipment.
- This power supply unit has a built-in fan for air-cooling. Do not block air intake and exhaust. It might cause fire.
- Input voltage, Output current, Output power, ambient temperature and ambient humidity should be used within specifications, otherwise the unit will be damaged.
- For application equipment, which requires very high reliability (Nuclear related equipment, traffic control equipment, medical equipment, etc), please provide fail safety function in the equipment.
- Confirm connections to input/output terminals and signal terminals are correct as indicated in the instruction manual.
- Do not use the product in environment with strong electromagnetic field, corrosive gas and conductive substance.
- Do not operate and store this unit at an environment where condensation occur. In such case, waterproof treatment is necessary
- This information in this document is subject to change without prior notice. For actual design-in, please refer to the latest publications of data sheet, etc., for the most up-to date specifications of the unit.
- No part of this document may be copied or reproduced in any form without prior written consent of Densai-Lambda.
- Do not inject abnormal voltage to output terminal and signal terminal from the outside. The injection of reverse voltage or over voltage exceeding nominal output voltage to output terminals might cause damage to internal components.
- Never operate the unit under over current or shorted condition. Insulation failure, smoking, burning or other damage may occur to the unit.
- This power supply is a PC board type unit using SMD. PCB stress such as bending, twisting could cause damage. Therefore, please handle with care.

DWG NO. : DA024-04-01

APPD	CHK	DWG
<i>K. Nakijō</i>	<i>K. Asami</i>	<i>M. Tabuchi</i>
01. Aug. 2006	30. Aug. 2006	29. Aug. 2006

1. Fan Life span Expectancy

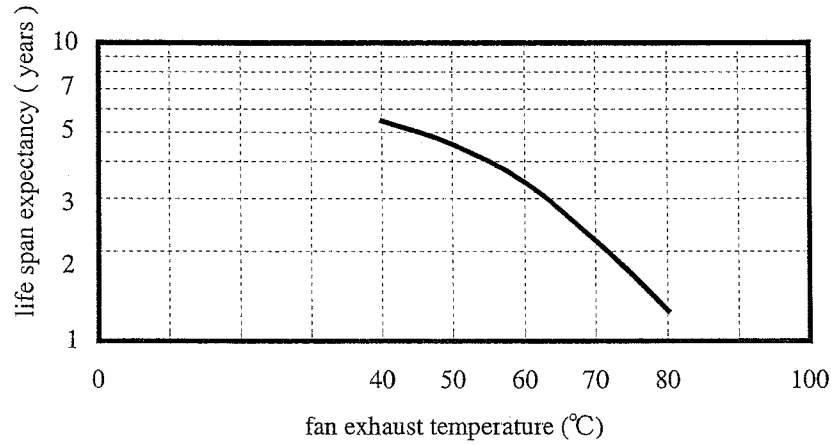

Life expectancy fan exhaust temperature 45°C 45,000 hours

fan exhaust temperature 80°C 11,000 hours

2. Fan Installation

The HWS1500 fan is a unit that consist of a fan and a rear panel.

Connection between fan unit and power supply unit is through fan power cable connector.

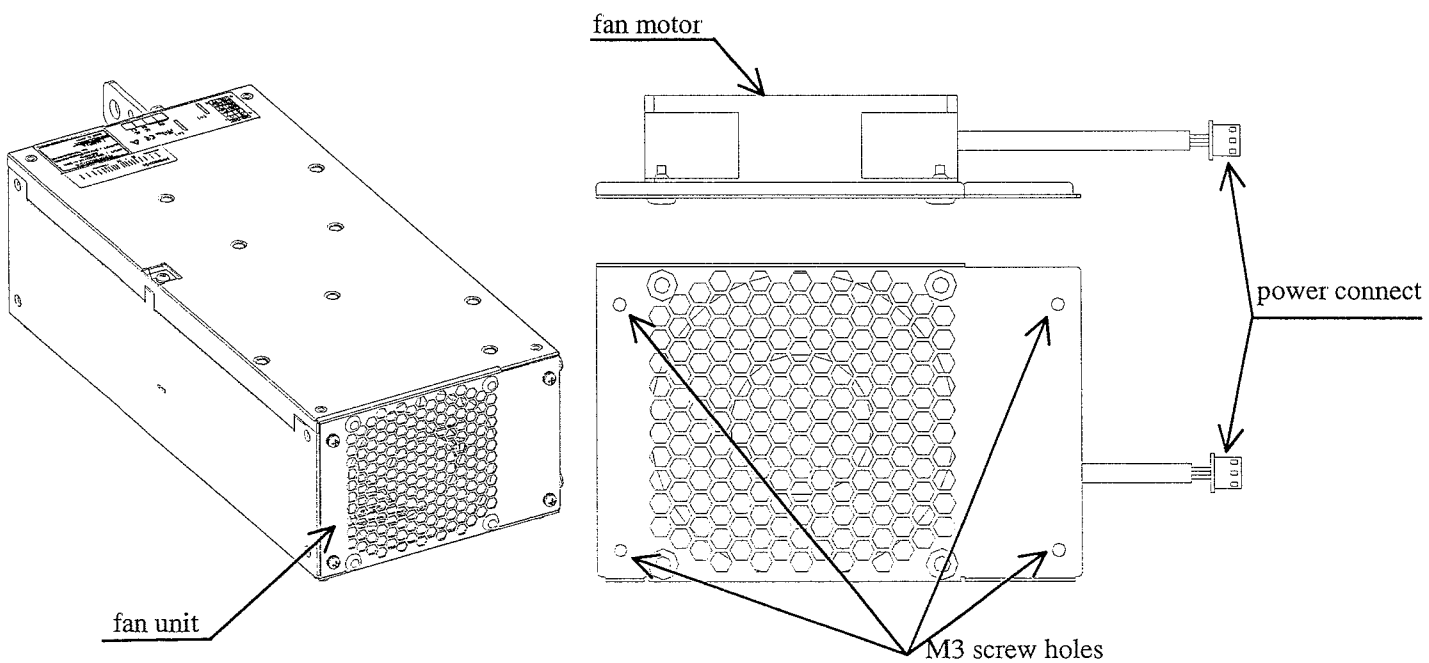

fig.2-1 Fan Unit Position and Shape

3. Fan Replacement Method

3-1 Preparation

- ① Prepare a new fan unit set (1500-FAN-01)
- ② Switch off input voltage and stop the equipment. Allow certain high temperature section caused by heating to cool down before replacing fan.



Please kindly refer to the installation manual on how to properly stop the equipment. Failure to do so might result in injury, burn or electric shock.

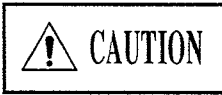

Fan replacement on an operating equipment is strictly prohibited. This might cause injury, burn or electric shock.



Please avoid from inserting any form of object (finger, stick, etc.) into fan while it is spinning. This might result in an injury.

3-2 Fan Unit Detachment Method

Fan unit is detach from the equipment after fan has completely stop and input voltage is switched off.

- ① Remove M3x6 screws located at 4 corners of the fan unit.
- ② Fan unit is pull out from power supply unit.
Disconnect power cable connector and detach fan unit.

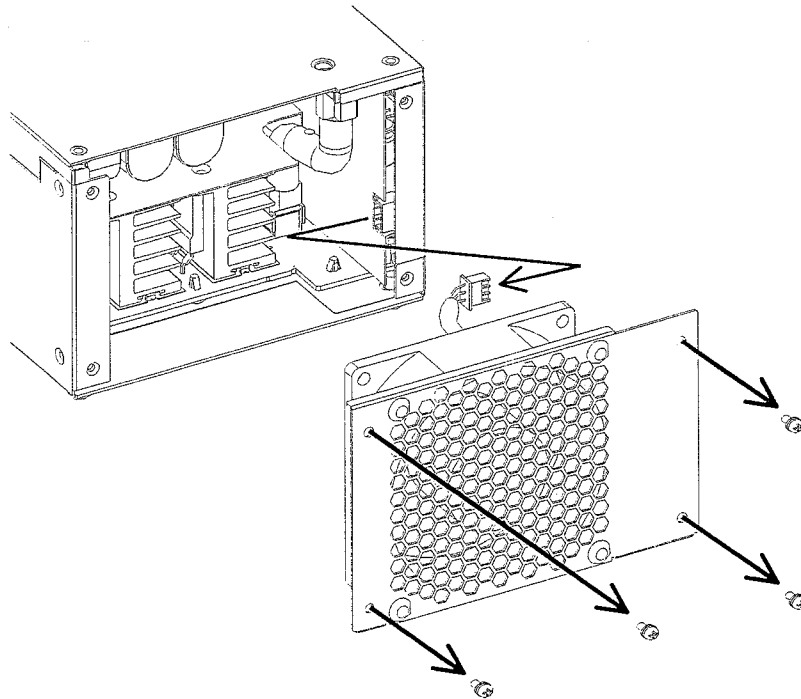

fig. 3-1 Fan Unit Detachment Method



After fan is remove, do not insert anything into the opening section. Certain section in the equipment is electrify with high voltage or high temperature due to heat. This might cause injury, burn or electric shock.



Firmly secure the equipment and hold the fan unit power cable connector. Then carefully disconnect the connector. Excessive stress might damage the connector.

3-3 Fan Unit Installation Method



This fan motor uses a precise ball bearing. Please avoid from dropping, applying shock to the fan as it will have a negative (unusual sound, life span decrease) effect to the fan.

Install the new fan unit after the old fan have been detached.

- ① Check the fan unit installation position.
- ② Hold the power cable connector and connect it to the connector on the board. Excessive stress might damage the connector. Make sure that the power cable connector is connected according to the correct direction.
- ③ Make sure that the cable is not stuck between sheet metal or come in contact with fan blades while inserting into equipment. Screw in M3x6 screws into holes located at 4 corners of the fan unit to attach it to the equipment.

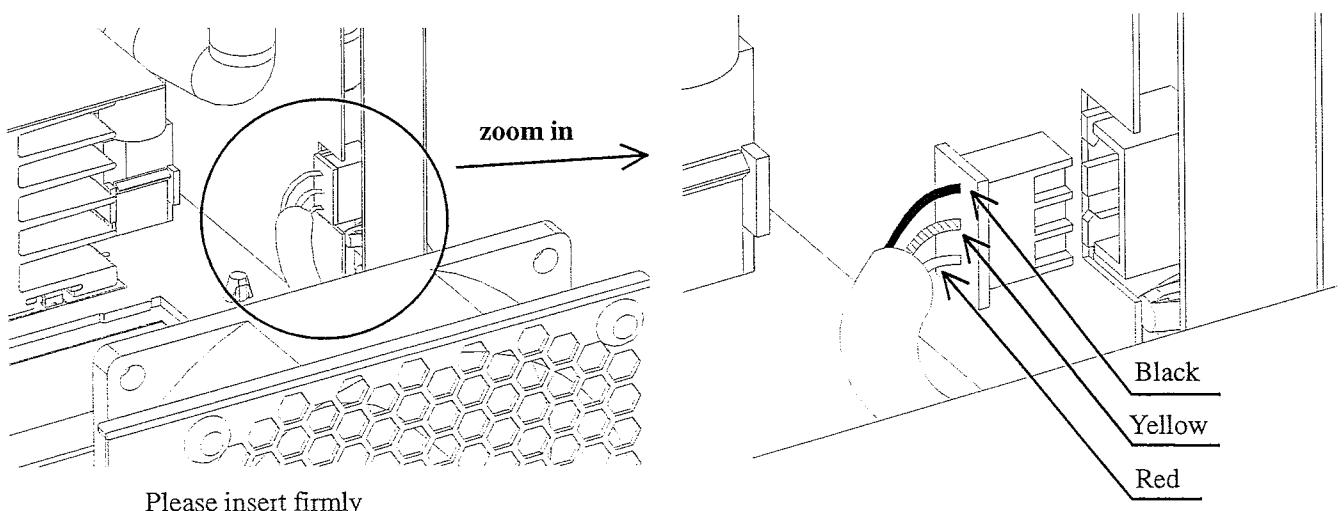
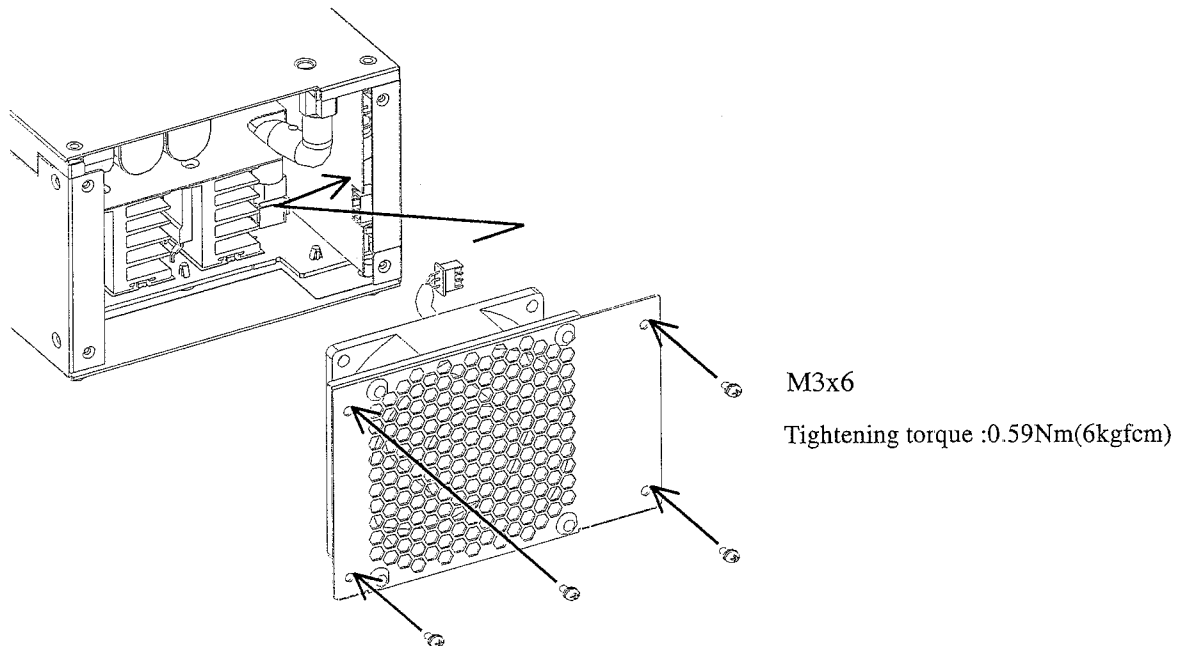

4. Procedure After Replacement

Please kindly contact our sales office or request through a specialize company for disposal of old fan unit.

It is recommended to keep a record of the present fan unit replacement date and the next fan unit replacement date.

Dust might block the equipment's inlet and outlet. This will result in damaging the equipment, interfering with the cooling system and cause over heating. It is advisable to always keep the unit's inlet and outlet clean and replace the fan when the time comes.

Start the equipment after completing replacement according to the procedure stated in the equipment instruction manual.

5. Fan Unit Order Method

Please contact our sales office or our distributor for fan unit supply.

Sales office and distributor are listed at the back of our catalog.

Delivery of fan unit might require time. Therefore it is advisable to place an order 3 - 6months prior to the replacement.

Please provide the information below when placing an order through our sales office or distributor.

①Equipment name : HWS1500

②Model : 1500-FAN-01

③Date of purchase

④Fan replacement schedule

⑤Serial number (printed on a white label on the top side of the equipment)

⑥Quantity required

6. Fan Unit Detail

Fan motor : Model : 9A0812G4D031 (SANYO DENKI)

Power cable connector : housing : XHP-3 (J.S.T)

contact : SXH-001T-P0.6 (J.S.T)

Weight : 150 (g)

Mouser Electronics

Authorized Distributor

Click to View Pricing, Inventory, Delivery & Lifecycle Information:

[TDK-Lambda:](#)

[1500-FAN-01](#)



Компания «ЭлектроПласт» предлагает заключение долгосрочных отношений при поставках импортных электронных компонентов на взаимовыгодных условиях!

Наши преимущества:

- Оперативные поставки широкого спектра электронных компонентов отечественного и импортного производства напрямую от производителей и с крупнейших мировых складов;
- Поставка более 17-ти миллионов наименований электронных компонентов;
- Поставка сложных, дефицитных, либо снятых с производства позиций;
- Оперативные сроки поставки под заказ (от 5 рабочих дней);
- Экспресс доставка в любую точку России;
- Техническая поддержка проекта, помощь в подборе аналогов, поставка прототипов;
- Система менеджмента качества сертифицирована по Международному стандарту ISO 9001;
- Лицензия ФСБ на осуществление работ с использованием сведений, составляющих государственную тайну;
- Поставка специализированных компонентов (Xilinx, Altera, Analog Devices, Intersil, Interpoint, Microsemi, Aeroflex, Peregrine, Syfer, Eurofarad, Texas Instrument, Miteq, Cobham, E2V, MA-COM, Hittite, Mini-Circuits, General Dynamics и др.);

Помимо этого, одним из направлений компании «ЭлектроПласт» является направление «Источники питания». Мы предлагаем Вам помощь Конструкторского отдела:

- Подбор оптимального решения, техническое обоснование при выборе компонента;
- Подбор аналогов;
- Консультации по применению компонента;
- Поставка образцов и прототипов;
- Техническая поддержка проекта;
- Защита от снятия компонента с производства.



Как с нами связаться

Телефон: 8 (812) 309 58 32 (многоканальный)

Факс: 8 (812) 320-02-42

Электронная почта: org@eplast1.ru

Адрес: 198099, г. Санкт-Петербург, ул. Калинина, дом 2, корпус 4, литера А.