



Is Now Part of



**ON Semiconductor®**

To learn more about ON Semiconductor, please visit our website at  
[www.onsemi.com](http://www.onsemi.com)

Please note: As part of the Fairchild Semiconductor integration, some of the Fairchild orderable part numbers will need to change in order to meet ON Semiconductor's system requirements. Since the ON Semiconductor product management systems do not have the ability to manage part nomenclature that utilizes an underscore (\_), the underscore (\_) in the Fairchild part numbers will be changed to a dash (-). This document may contain device numbers with an underscore (\_). Please check the ON Semiconductor website to verify the updated device numbers. The most current and up-to-date ordering information can be found at [www.onsemi.com](http://www.onsemi.com). Please email any questions regarding the system integration to [Fairchild\\_questions@onsemi.com](mailto:Fairchild_questions@onsemi.com).

ON Semiconductor and the ON Semiconductor logo are trademarks of Semiconductor Components Industries, LLC dba ON Semiconductor or its subsidiaries in the United States and/or other countries. ON Semiconductor owns the rights to a number of patents, trademarks, copyrights, trade secrets, and other intellectual property. A listing of ON Semiconductor's product/patent coverage may be accessed at [www.onsemi.com/site/pdf/Patent-Marking.pdf](http://www.onsemi.com/site/pdf/Patent-Marking.pdf). ON Semiconductor reserves the right to make changes without further notice to any products herein. ON Semiconductor makes no warranty, representation or guarantee regarding the suitability of its products for any particular purpose, nor does ON Semiconductor assume any liability arising out of the application or use of any product or circuit, and specifically disclaims any and all liability, including without limitation special, consequential or incidental damages. Buyer is responsible for its products and applications using ON Semiconductor products, including compliance with all laws, regulations and safety requirements or standards, regardless of any support or applications information provided by ON Semiconductor. "Typical" parameters which may be provided in ON Semiconductor data sheets and/or specifications can and do vary in different applications and actual performance may vary over time. All operating parameters, including "Typicals" must be validated for each customer application by customer's technical experts. ON Semiconductor does not convey any license under its patent rights nor the rights of others. ON Semiconductor products are not designed, intended, or authorized for use as a critical component in life support systems or any FDA Class 3 medical devices or medical devices with a same or similar classification in a foreign jurisdiction or any devices intended for implantation in the human body. Should Buyer purchase or use ON Semiconductor products for any such unintended or unauthorized application, Buyer shall indemnify and hold ON Semiconductor and its officers, employees, subsidiaries, affiliates, and distributors harmless against all claims, costs, damages, and expenses, and reasonable attorney fees arising out of, directly or indirectly, any claim of personal injury or death associated with such unintended or unauthorized use, even if such claim alleges that ON Semiconductor was negligent regarding the design or manufacture of the part. ON Semiconductor is an Equal Opportunity/Affirmative Action Employer. This literature is subject to all applicable copyright laws and is not for resale in any manner.

# FAN7631

## Advanced Pulse Frequency Modulation (PFM) Controller for Half-Bridge Resonant Converters

### Features

- Variable Frequency Control with 50% Duty Cycle for Half-Bridge Resonant Converter Topologies
- High Efficiency with Zero-Voltage-Switching (ZVS)
- Up to 600kHz Operating Frequency
- Built-in High-Side Gate Driver
- High Gate-Driving Current: +500mA/-1000mA
- Programmable Dead Time with a Resistor
- Pulse Skipping and Burst Operation for Frequency Limit (Programmable) at Light-Load Condition
- Simple Remote On/Off Control with Latch or Auto-Restart (A/R) Using FI or LS Pin
- Protection Functions: Over-Voltage Protection (OVP), Overload Protection (OLP), Over-Current Protection (OCP), Abnormal Over-Current Protection (AOCP), Internal Thermal Shutdown (TSD), and High Precise Line Under-Voltage Lockout (LUVLO)
- Level-Change OCP Function During Startup

### Applications

- PDP and LCD TVs
- Desktop PCs and Servers
- Video Game Consoles
- Adapters
- Telecom Power Supplies

### Description

The FAN7631 is a pulse-frequency modulation controller for high-efficiency half-bridge resonant converters that includes a high-side gate drive circuit, an accurate current-controlled oscillator, and various protection functions. The FAN7631 features include variable dead time, operating frequency up to 600kHz, protections such as LUVLO, and a selectable latch or A/R protection using the LS pin for user convenience.

The Zero-Voltage-Switching (ZVS) technique reduces the switching losses and improves the efficiency significantly. ZVS also reduces the switching noise noticeably, which allows a small Electromagnetic Interference (EMI) filter.

Offering everything necessary to build a reliable and robust resonant converter, the FAN7631 simplifies designs and improves productivity and performance. The FAN7631 can be applied to resonant converter topologies such as series resonant, parallel resonant, and LLC resonant converters.

### Related Resources

[AN4151 — Half-Bridge LLC Resonant Converter Design Using FSFR-Series Fairchild Power Switch \(FPS™\)](#)

### Ordering Information

Part Number	Operating Junction Temperature	Package	Packaging Method
FAN7631SJ	-40°C ~ 130°C	16-Lead, Small-Outline Package (SOP)	Tube
FAN7631SJX			Tape & Reel

### Application Circuit Diagram

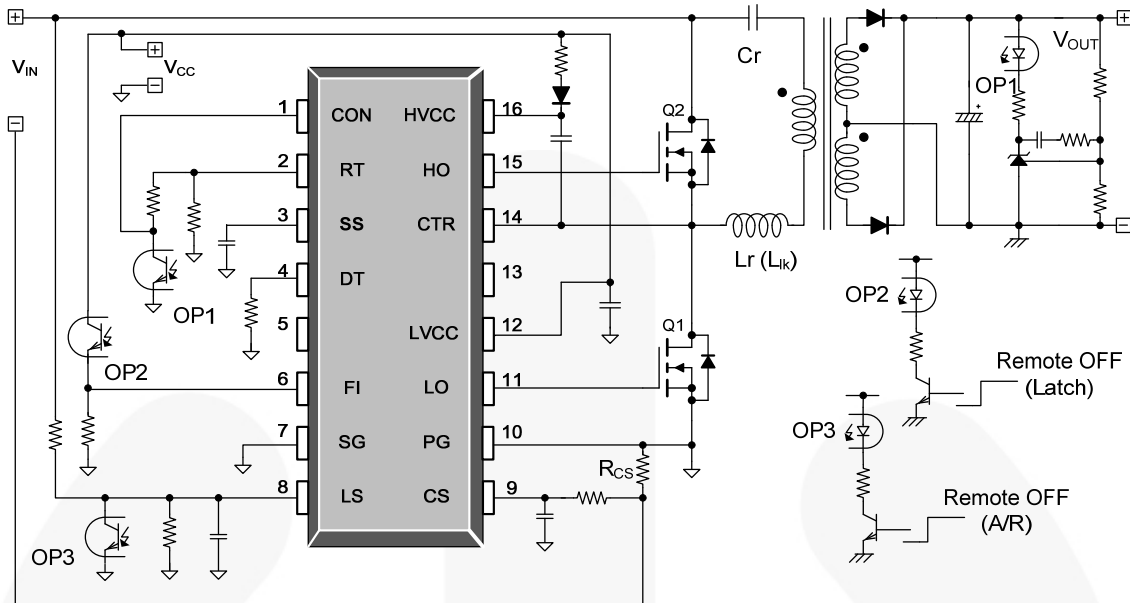

Figure 1. Typical Application Circuit (Resonant Half-Bridge Converter)

### Block Diagram

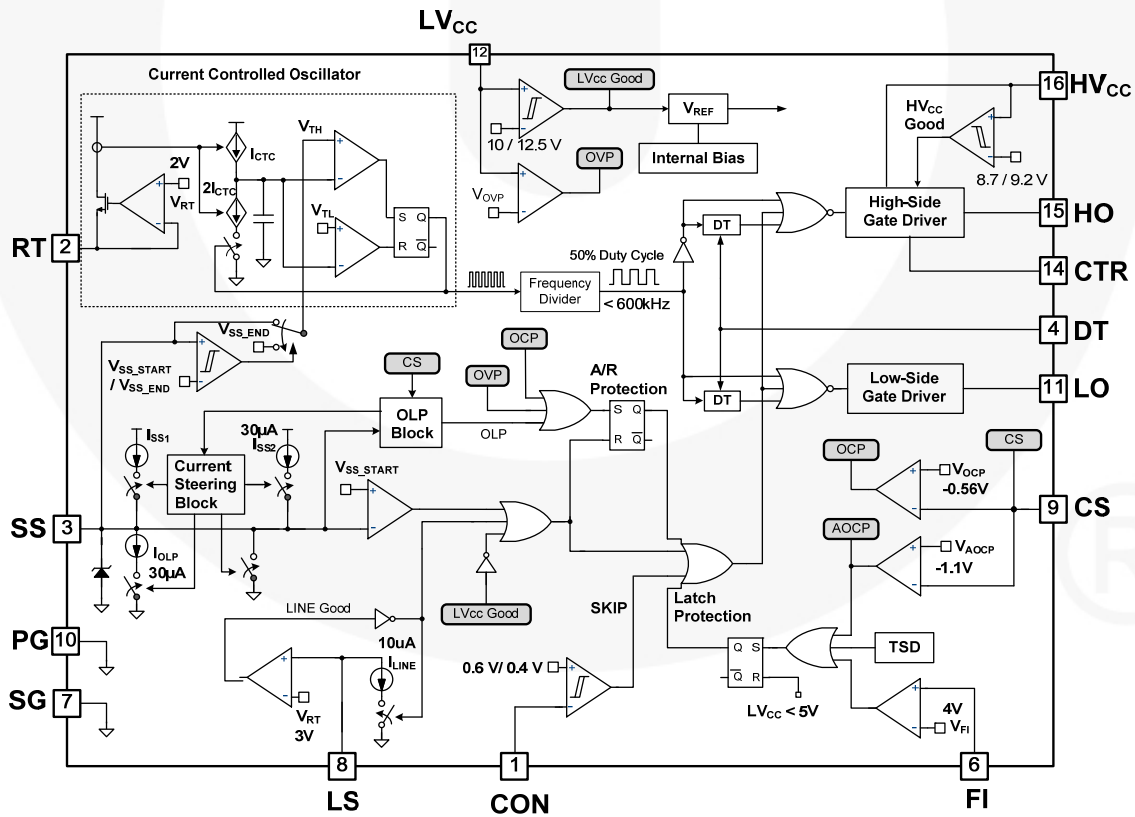

Figure 2. Internal Block Diagram

## Pin Configuration

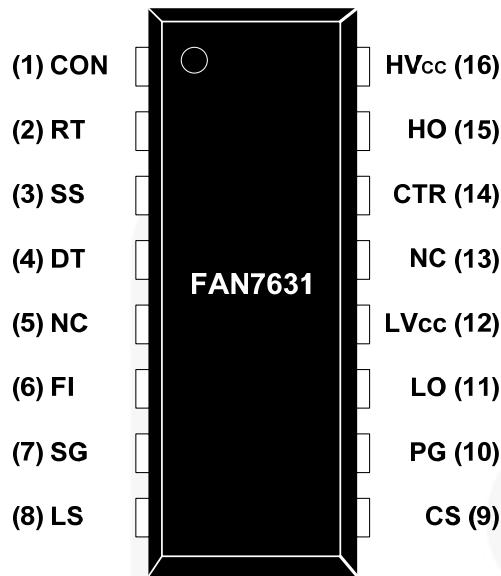

Figure 3. Package Pin Assignments (16SOP)

## Pin Definitions

Pin #	Name	Description
1	CON	This pin is used to enable / disable the gate drive outputs for pulse-skipping operation. When the voltage of this pin is above 0.6V, the gate drive outputs are enabled. When the voltage of this pin drops below 0.4V, gate drive signals for both MOSFETs are disabled.
2	RT	This pin programs the switching frequency. Typically, an opto-coupler is connected to this pin to control the switching frequency for the output voltage regulation.
3	SS	This pin is used to program the soft-start time and overload protection delay. It also programs the restart delay when the converter auto recovers from the protection states. Typically, a small capacitor is connected on this pin.
4	DT	This pin is to adjust the dead time using an external resistor.
5	NC	No connection
6	FI	User protection function / fault input. This pin can be used as a latch protection, which is operated when a voltage applied to this pin is higher than 4V <sub>DC</sub> .
7	SG	This pin is the ground of the control part.
8	LS	This pin senses the line voltage for line under-voltage lockout (LUVLO).
9	CS	This pin senses the current flowing through the main MOSFET. Typically, negative voltage is applied on this pin.
10	PG	This pin is the power ground. This pin typically connects to the source of the low-side MOSFET.
11	LO	This pin is used for the low-side gate-driving signal.
12	LV <sub>CC</sub>	This pin is for the supply voltage of the control IC and low-side gate-driving circuit.
13	NC	No connection
14	CTR	This pin is connected to the drain of the low-side MOSFET. Typically, a transformer is connected to this pin.
15	HO	This pin is used for the high-side gate-driving signal.
16	HV <sub>CC</sub>	This pin is used for the supply voltage of the high-side gate-driving circuit.

## Absolute Maximum Ratings

Stresses exceeding the absolute maximum ratings may damage the device. The device may not function or be operable above the recommended operating conditions. Extended exposure to stresses above the recommended operating conditions may affect device reliability so that any test which is stressing the parts to these levels is not recommended. The absolute maximum ratings are stress ratings only.  $T_A=25^{\circ}\text{C}$  unless otherwise specified.

Symbol	Parameter	Min.	Max.	Unit
$\text{HV}_{\text{CC}}$ to $\text{V}_{\text{CTR}}$	High-Side $\text{V}_{\text{CC}}$ Pin to Center Voltage	-0.3	25.0	V
$\text{HV}_{\text{CC}}$	High-Side Floating Supply Voltage	-0.3	625.0	V
$\text{V}_{\text{HO}}$	High-Side Gate Driving Voltage	$\text{V}_{\text{CTR}}-0.3$	$\text{HV}_{\text{CC}}+0.3$	V
$\text{V}_{\text{CTR}}$	High-Side Offset Voltage	$\text{HV}_{\text{CC}}-25$	$\text{HV}_{\text{CC}}+0.3$	V
	Allowable Negative $\text{V}_{\text{CTR}}$ at $15\text{V}_{\text{DC}}$ Applied $\text{HV}_{\text{CC}}$ to CTR Pin	-9.8	-7.0	V
$\text{LV}_{\text{CC}}$	Low-Side Supply Voltage	-0.3	25.0	V
$\text{V}_{\text{LO}}$	Low-Side Gate Driving Voltage	-0.3	$\text{LV}_{\text{CC}}$	V
$\text{V}_{\text{CON}}$	Control Pin Input Voltage	-0.3	$\text{LV}_{\text{CC}}$	V
$\text{V}_{\text{CS}}$	Current Sense (CS) Pin Input Voltage	-5.0	1.0	V
$\text{V}_{\text{RT}}$	RT Pin Input Voltage	-0.3	5.0	V
$f_{\text{sw}}$	Recommended Switching Frequency	10	600	kHz
$\text{V}_{\text{LS}}$	LS Pin Input Voltage	-0.3	$\text{LV}_{\text{CC}}$	V
$\text{V}_{\text{FI}}$	FI Pin Input Voltage	-0.3	$\text{LV}_{\text{CC}}$	V
$\text{V}_{\text{SS}}$	SS Pin Input Voltage	-0.3	Internally Clamped <sup>(1)</sup>	V
$\text{V}_{\text{DT}}$	DT Pin Input Voltage	-0.3	Internally Clamped <sup>(1)</sup>	V
$d\text{V}_{\text{CTR}}/\text{dt}$	Allowable CTR Voltage Slew Rate		50	V/ns
$\text{P}_{\text{D}}$	Total Power Dissipation		1.24	W
$\text{T}_{\text{J}}$	Maximum Junction Temperature <sup>(2)</sup>		+150	$^{\circ}\text{C}$
	Recommended Operating Junction Temperature <sup>(2)</sup>	-40	+130	
$\text{T}_{\text{STG}}$	Storage Temperature Range	-55	+150	$^{\circ}\text{C}$

### Notes:

- $\text{V}_{\text{SS}}$  and  $\text{V}_{\text{DT}}$  are internally clamped at 5.0V, which has a tolerance between 4.75V and 5.25V.
- The maximum value of the recommended operating junction temperature is limited by thermal shutdown.

## Thermal Impedance

Symbol	Parameter	Value	Unit
$\theta_{\text{JA}}$	Junction-to-Ambient Thermal Impedance	102	$^{\circ}\text{C}/\text{W}$

## Electrical Characteristics

$T_A=25^{\circ}\text{C}$  and  $\text{LV}_{\text{CC}}=17\text{V}$  unless otherwise specified.

Symbol	Parameter	Condition	Min.	Typ.	Max.	Unit
<b>Supply Section</b>						
$I_{\text{LK}}$	Offset Supply Leakage Current	$\text{HV}_{\text{CC}}=\text{V}_{\text{CTR}}$			50	$\mu\text{A}$
$I_{\text{QHV}_{\text{CC}}}$	Quiescent $\text{HV}_{\text{CC}}$ Supply Current	$\text{HV}_{\text{CC,START}}-0.1\text{V}, \text{V}_{\text{CTR}}=0\text{V}$		50	120	$\mu\text{A}$
$I_{\text{QLV}_{\text{CC}}}$	Quiescent $\text{LV}_{\text{CC}}$ Supply Current	$\text{LV}_{\text{CC,START}}-0.1\text{V}, \text{V}_{\text{CTR}}=0\text{V}$		100	200	$\mu\text{A}$
$I_{\text{OHV}_{\text{CC}}}$	Operating $\text{HV}_{\text{CC}}$ Supply Current (RMS Value) <sup>(3)</sup>	$f_{\text{OSC}}=100\text{kHz}, C_{\text{Load}}=1\text{nF}, \text{V}_{\text{CON}} > 0.6\text{V}, \text{V}_{\text{CTR}}=0\text{V}$		3.0	4.5	$\text{mA}$
		$f_{\text{OSC}}=300\text{kHz}, C_{\text{Load}}=1\text{nF}, \text{V}_{\text{CON}} > 0.6\text{V}, \text{V}_{\text{CTR}}=0\text{V}$		8	10	$\text{mA}$
		$f_{\text{OSC}}=300\text{kHz}, \text{V}_{\text{CON}} < 0.4\text{V}, \text{V}_{\text{CTR}}=0\text{V}$ (No Switching)		100	200	$\mu\text{A}$
$I_{\text{OLV}_{\text{CC}}}$	Operating $\text{LV}_{\text{CC}}$ Supply Current (RMS Value) <sup>(3)</sup>	$f_{\text{OSC}}=100\text{kHz}, C_{\text{Load}}=1\text{nF}, \text{V}_{\text{CON}} > 0.6\text{V}, \text{V}_{\text{CTR}}=0\text{V}$		5	7	$\text{mA}$
		$f_{\text{OSC}}=300\text{kHz}, C_{\text{Load}}=1\text{nF}, \text{V}_{\text{CON}} > 0.6\text{V}, \text{V}_{\text{CTR}}=0\text{V}$		10	14	$\text{mA}$
		$f_{\text{OSC}}=300\text{kHz}, \text{V}_{\text{CON}} < 0.4\text{V}, \text{V}_{\text{CTR}}=0\text{V}$ (No Switching)		2.6	3.5	$\text{mA}$
<b>UVLO Section</b>						
$\text{LV}_{\text{CC,START}}$	$\text{LV}_{\text{CC}}$ UVLO Turn-On Threshold		11.2	12.5	13.8	V
$\text{LV}_{\text{CC,STOP}}$	$\text{LV}_{\text{CC}}$ UVLO Turn-Off Threshold		8.9	10.0	11.1	V
$\text{LV}_{\text{CC,HYS}}$	$\text{LV}_{\text{CC}}$ UVLO Hysteresis			2.5		V
$\text{HV}_{\text{CC,START}}$	$\text{HV}_{\text{CC}}$ UVLO Turn-On Threshold		8.2	9.2	10.2	V
$\text{HV}_{\text{CC,STOP}}$	$\text{HV}_{\text{CC}}$ UVLO Turn-Off Threshold		7.8	8.7	9.6	V
$\text{HV}_{\text{CC,HYS}}$	$\text{HV}_{\text{CC}}$ UVLO Hysteresis			0.5		V
<b>Oscillator &amp; Feedback Section</b>						
$\text{V}_{\text{BH}}$	Pulse Skip Disable Threshold Voltage		0.54	0.60	0.66	V
$\text{V}_{\text{BL}}$	Pulse Skip Enable Threshold Voltage		0.36	0.40	0.44	V
$\text{V}_{\text{RT}}$	Regulated RT Voltage		1.5	2.0	2.5	V
$f_{\text{OSC}}$	Output Oscillation Frequency	$\text{R}_{\text{T}}=11.6\text{k}\Omega, \text{C}_{\text{SS}}=1\text{nF}$	48	50	52	kHz
		$\text{R}_{\text{T}}=2.7\text{k}\Omega, \text{C}_{\text{SS}}=1\text{nF}$	188	200	212	
DC	Output Duty Cycle	$\text{R}_{\text{T}}=11.6\text{k}\Omega, \text{C}_{\text{Load}}=100\text{pF}$	49	50	51	%
		$\text{R}_{\text{T}}=2.7\text{k}\Omega, \text{C}_{\text{Load}}=100\text{pF}$	48	50	52	
<b>Soft-Start and Restart Section</b>						
$\text{I}_{\text{SS1}}$	Soft-Start Current 1	$\text{V}_{\text{CSS}}=0\text{V}, \text{LV}_{\text{CC}}=17\text{V}$	3			$\text{mA}$
$\text{I}_{\text{SS2}}$	Soft-Start Current 2	$\text{V}_{\text{CSS}}=1.6\text{V}, \text{LV}_{\text{CC}}=17\text{V}$	25	30	35	$\mu\text{A}$
$\text{V}_{\text{SS\_START}}$	Soft-Start Start Voltage	$\text{C}_{\text{SS}}=1\text{nF}, \text{V}_{\text{CON}}=3\text{V}$	1.5	1.6	1.7	V
$\text{V}_{\text{SS\_END}}$	Soft-Start End Voltage	$\text{C}_{\text{SS}}=1\text{nF}, \text{V}_{\text{CON}}=3\text{V}$	4.0	4.2	4.4	V
$\text{V}_{\text{SSC}}$	Clamped Soft-Start Voltage	$\text{C}_{\text{SS}}=1\text{nF}, \text{V}_{\text{CON}}=3\text{V}$	4.75	5.00	5.25	V
$f_{\text{OSC\_SS}}$	Initial Output Oscillation Frequency During Soft-Start	$\text{R}_{\text{T}}=11.6\text{k}\Omega, \text{V}_{\text{CSS}}=1.6\text{V}$		300		kHz
		$\text{R}_{\text{T}}=5.8\text{k}\Omega$		530		
		$\text{R}_{\text{T}}=2.7\text{k}\Omega$	600			
$\text{V}_{\text{RT\_CON}}$	RT-CON Voltage for Startup			60	120	mV

Continued on the following page...

**Electrical Characteristics** (Continued)T<sub>A</sub>=25°C and LV<sub>CC</sub>=17V unless otherwise specified.

Symbol	Parameter	Condition	Min.	Typ.	Max.	Unit
<b>Output Section</b>						
I <sub>source</sub>	Peak Sourcing Current	LV <sub>CC</sub> =HV <sub>CC</sub> =17V, T <sub>J</sub> =-40°C ~ 130°C	500			mA
I <sub>sink</sub>	Peak Sinking Current	HV <sub>CC</sub> =17V, T <sub>J</sub> =-40°C ~ 130°C	1000			mA
t <sub>r</sub>	Rising Time	HV <sub>CC</sub> =17V, C <sub>Load</sub> =1nF		40		ns
t <sub>f</sub>	Falling Time			20		ns
V <sub>HOH</sub>	High Level of High-Side Gate Signal (V <sub>HVCC</sub> -V <sub>HO</sub> )	I <sub>O</sub> =20mA			1.0	V
V <sub>HOL</sub>	Low Level of High-Side Gate Signal				0.6	V
V <sub>LOH</sub>	High Level of Low-Side Gate Signal (V <sub>LVCC</sub> -V <sub>LO</sub> )				1.0	V
V <sub>LOL</sub>	Low Level of Low-Side Gate Signal				0.6	V
<b>Protection Section</b>						
I <sub>OLP</sub>	OLP Sink Current		25	30	35	μA
V <sub>OLP</sub>	OLP Threshold Voltage		-0.42	-0.37	-0.32	V
t <sub>BOL</sub>	OLP Blanking Time <sup>(3)</sup>		150	200	250	ns
V <sub>OCP</sub>	OCP Threshold Voltage		-0.62	-0.56	-0.50	V
t <sub>BO</sub>	OCP Blanking Time <sup>(3)</sup>		150	200	250	ns
V <sub>AOCP</sub>	AOCP Threshold Voltage		-1.21	-1.10	-0.99	V
t <sub>BAO</sub>	AOCP Blanking Time <sup>(3)</sup>			50		ns
t <sub>DA</sub>	Delay Time (Low Side) Detecting from V <sub>AOCP</sub> to Switch Off <sup>(3)</sup>			250	400	ns
V <sub>OVP</sub>	LV <sub>CC</sub> Over-Voltage Protection		21	23	25	V
V <sub>LINE</sub>	Line UVLO Threshold Voltage	V <sub>LS</sub> Sweep, -40°C ~ 130°C	2.88	3.00	3.12	V
I <sub>LINE</sub>	Line UVLO Hysteresis Current	V <sub>LS</sub> =2V	9	10	11	μA
T <sub>SD</sub>	Thermal Shutdown Temperature <sup>(3)</sup>		130	140	150	°C
V <sub>FI</sub>	Fault Input Threshold Voltage for Latch Operation		3.8	4.0	4.2	V
I <sub>LR</sub>	Latch-Protection Sustain LV <sub>CC</sub> Supply Current	LV <sub>CC</sub> =7.5V		100	150	μA
V <sub>LR</sub>	Latch-Protection Reset LV <sub>CC</sub> Supply Voltage		5			V
<b>Dead-Time Control Section</b>						
D <sub>T</sub>	Dead Time	R <sub>DT</sub> =2.7kΩ, C <sub>Load</sub> =1nF	100	150	200	ns
		R <sub>DT</sub> =18kΩ, C <sub>Load</sub> =1nF	250	350	450	
		Short, C <sub>Load</sub> =1nF		50		
		Open, C <sub>Load</sub> =1nF		1000		
Recommended Dead Time Range			100		600	

**Note:**

3. This parameter, although guaranteed, is not tested in production.

## Typical Performance Characteristics

These characteristic graphs are normalized at  $T_A=25^{\circ}\text{C}$ .

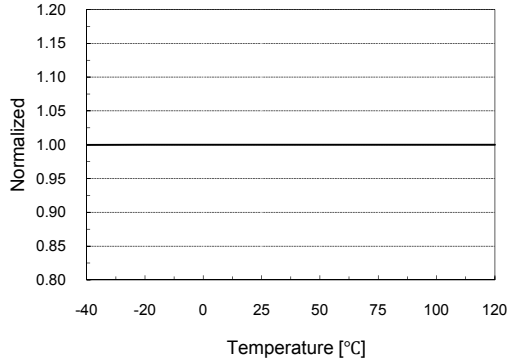

**Figure 4. LV<sub>CC</sub> Start Voltage vs. Temperature**

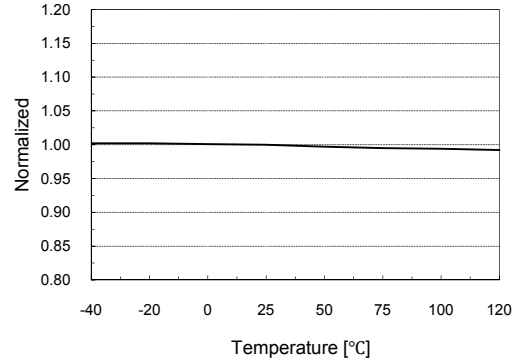

**Figure 5. LV<sub>CC</sub> Stop Voltage vs. Temperature**

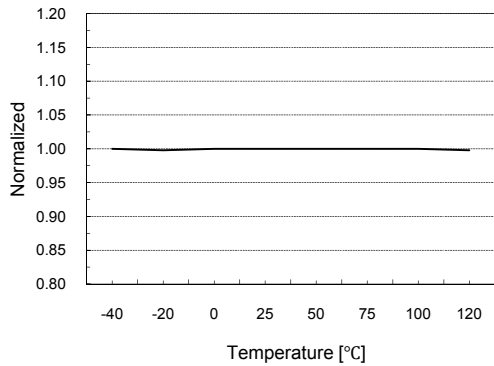

**Figure 6. HV<sub>CC</sub> Start Voltage vs. Temperature**

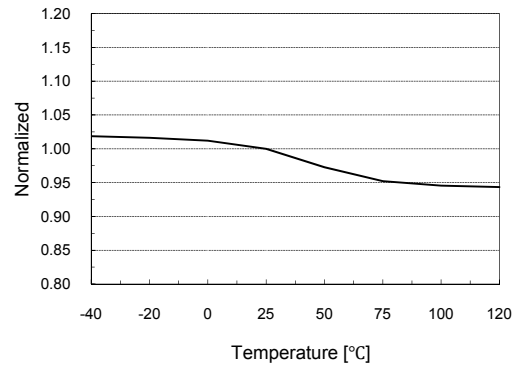

**Figure 7. HV<sub>CC</sub> Stop Voltage vs. Temperature**

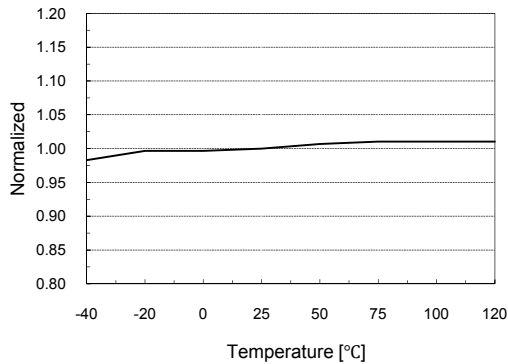

**Figure 8. Pulse Skip Disable Voltage vs. Temperature**

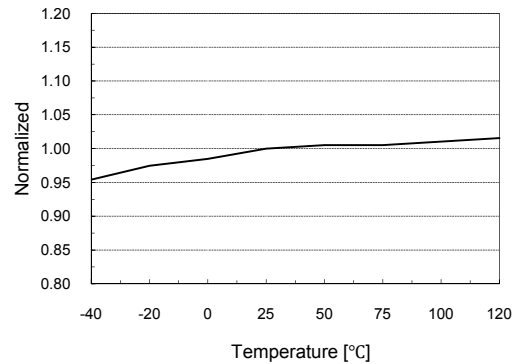

**Figure 9. Pulse Skip Enable Voltage vs. Temperature**



## Typical Performance Characteristics (Continued)

These characteristic graphs are normalized at  $T_A=25^\circ\text{C}$ .

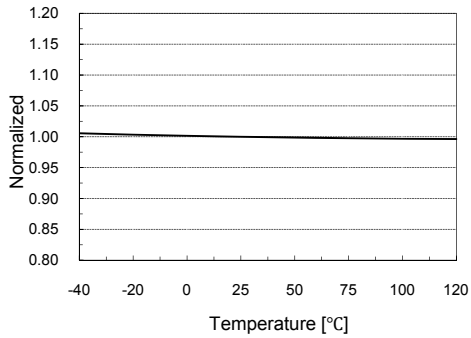

Figure 10. Regulated  $R_T$  Voltage vs. Temperature

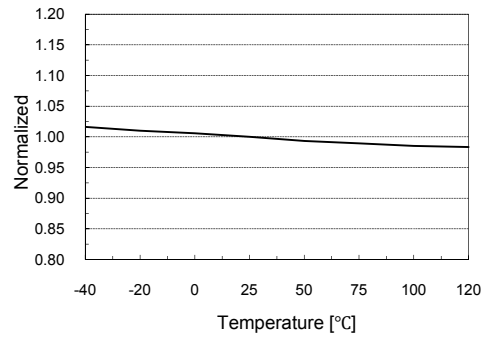

Figure 11. Output Oscillation Frequency ( $R_T=11.6\text{k}\Omega$ ) vs. Temperature

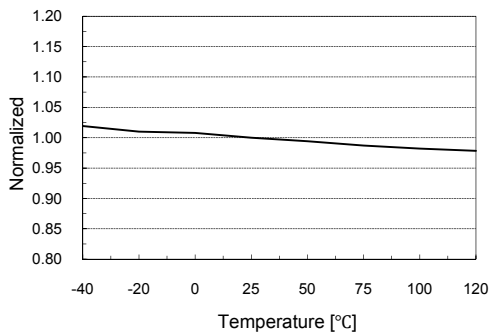

Figure 12. Output Oscillation Frequency ( $R_T=2.7\text{k}\Omega$ ) vs. Temperature

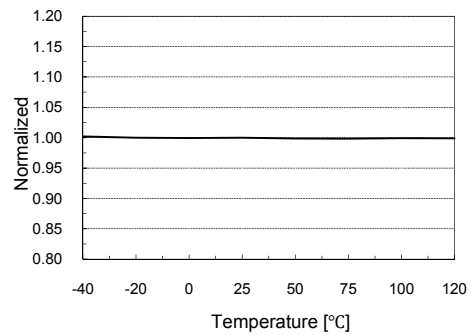

Figure 13. Output Duty Cycle ( $R_T=11.6\text{k}\Omega$ ) vs. Temperature

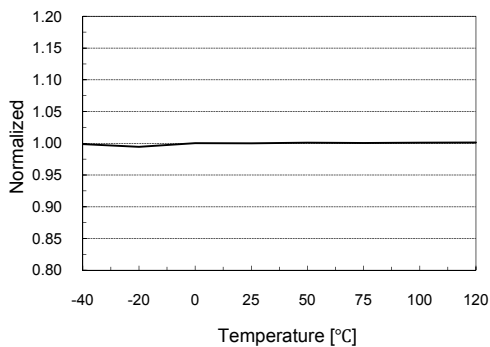

Figure 14. Output Duty Cycle ( $R_T=2.7\text{k}\Omega$ ) vs. Temperature

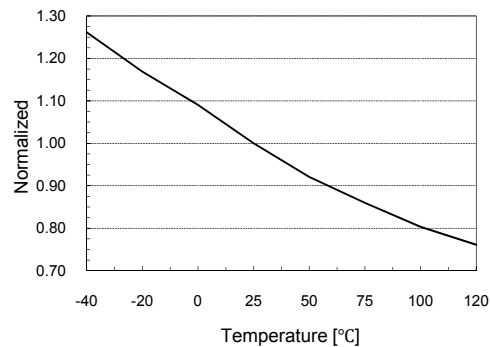

Figure 15.  $I_{SS1}$  vs. Temperature

## Typical Performance Characteristics (Continued)

These characteristic graphs are normalized at  $T_A=25^\circ\text{C}$ .

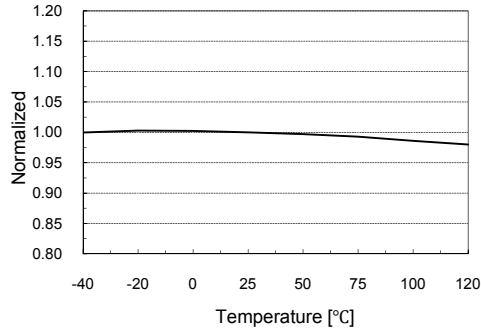

Figure 16.  $I_{SS2}$  vs. Temperature

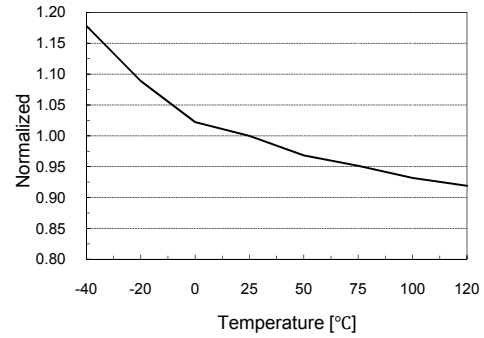

Figure 17.  $f_{osc\_ss}$  ( $R_T=11.6\text{k}\Omega$ ) vs. Temperature

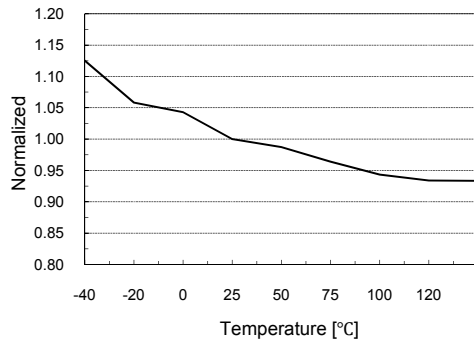

Figure 18.  $f_{osc\_ss}$  ( $R_T=2.7\text{k}\Omega$ ) vs. Temperature

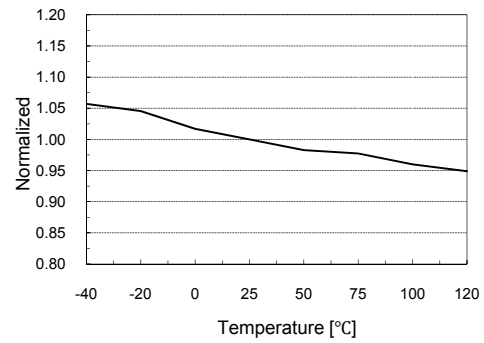

Figure 19.  $V_{OLP}$  vs. Temperature

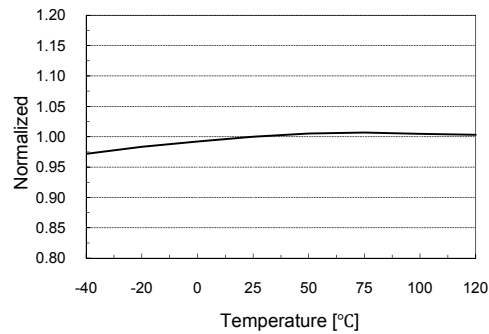

Figure 20.  $I_{OLP}$  vs. Temperature

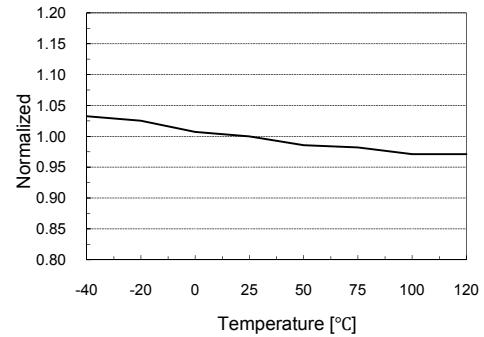
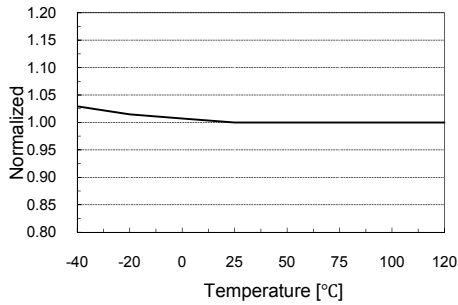

Figure 21.  $V_{OCP}$  vs. Temperature

## Typical Performance Characteristics (Continued)

These characteristic graphs are normalized at  $T_A=25^\circ\text{C}$ .



**Figure 22.  $V_{AOCP}$  vs. Temperature**

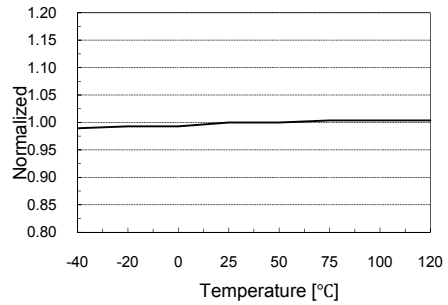

**Figure 23.  $V_{OVP}$  vs. Temperature**

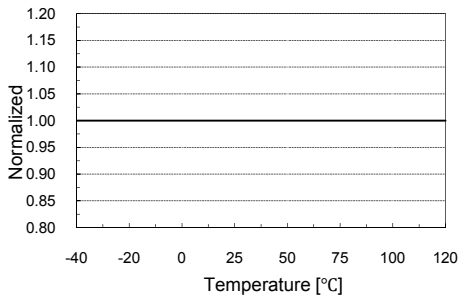

**Figure 24.  $V_{LINE}$  vs. Temperature**

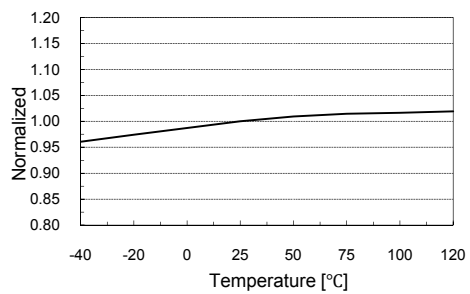

**Figure 25.  $I_{LINE}$  vs. Temperature**

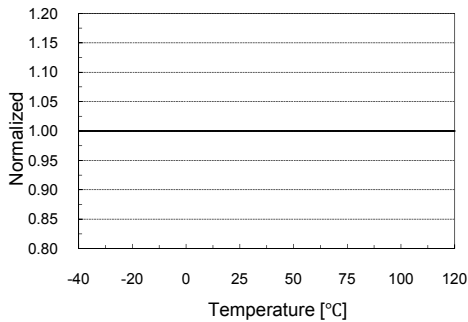

**Figure 26.  $V_{FI}$  vs. Temperature**

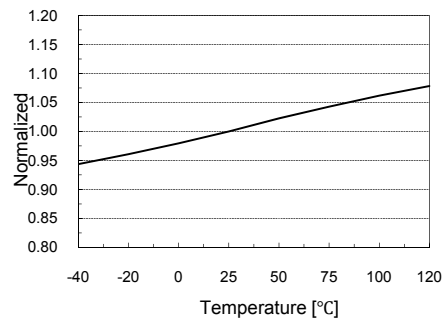

**Figure 27. Dead Time ( $D_T=150\text{ns}$ ) vs. Temperature**

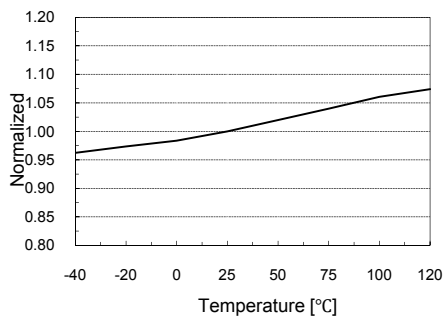

**Figure 28. Dead Time ( $D_T=350\text{ns}$ ) vs. Temperature**

## Functional Description

### 1. Internal Oscillator

Figure 29 shows the simplified circuit of internal current-controlled oscillator and typical circuit configuration for the RT pin. Internally, the voltage on the RT pin is regulated at 2V by the V/I converter. The charging / discharging current for the oscillator capacitor,  $C_T$ , is obtained by mirroring the current flowing out of the RT pin ( $I_{CTC}$ ). By comparing the capacitor voltage with  $V_{TH}$  and  $V_{TL}$  and driving S/R flip-flop with the comparator outputs, the clock signal is obtained. Thus, the switching frequency increases as the RT pin current increases.

As can be seen in Figure 29, an opto-coupler transistor is typically connected to the RT pin through  $R_{max}$  to modulate the switching frequency. During an overload condition, the opto-coupler is fully turned off and  $I_{CTC}$  is solely determined by  $R_{min}$ , which sets the minimum frequency. Meanwhile, the maximum switching frequency is obtained when the opto-coupler is fully turned on. Considering the typical saturation voltage of opto-transistor (0.2V), the maximum frequency can be obtained by  $R_{max}$  and  $R_{min}$  as:

$$f_{min} = \frac{11.6k\Omega}{R_{min}} \times 50kHz \quad (1)$$

$$f_{max} = \left( \frac{11.6k\Omega}{R_{min}} + \frac{10.4k\Omega}{R_{max}} \right) \times 50kHz$$

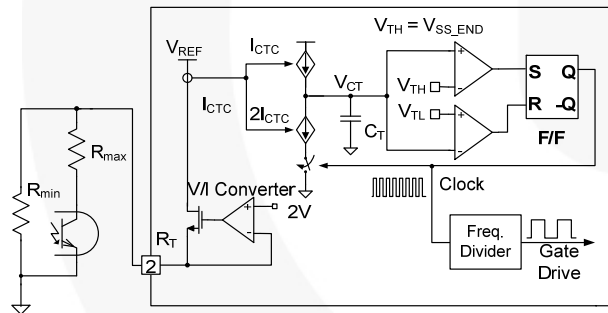

Figure 29. Current-Controlled Oscillator

### 2. Gate Driver and Dead Time Programming

The FAN7631 employs a gate drive circuit with high driving capability (source: 0.5A / sink: 1A) to cover a wide variety of applications. The two gate drive signals (LO and HO) are complimentary; each signal has 50% duty cycle, including the dead time, as shown in Figure 30.

The dead time can be programmed by the resistor,  $R_{DT}$ , as shown in Figure 31. Internally, the voltage on the DT pin is regulated at 1.4V by the V/I converter and  $I_{DT}$  programs the dead time using  $R_{DT}$ . To improve the noise immunity of the dead time circuit, a sample-and-hold circuit is internally employed. However, severe noises in a high-power application can affect the dead time circuit operation and it is therefore recommended to use a bypass capacitor of around 10nF in parallel with the  $R_{DT}$ . As a protective measure against abnormal conditions,

such as DT pin short-to-ground and lift open, shunt-resistor and series resistor  $R_{DT,short}$  and  $R_{DT,open}$  are internally connected to the DT pin. Even when this pin is shorted to ground and lifted open, the dead time is limited to 50ns (short to ground) and 1000ns (lifted open). Since the internal resistors have relatively large tolerance, it is recommended to set the dead time between 150ns and 600ns to minimize the dead time variation by the internal resistor tolerance.

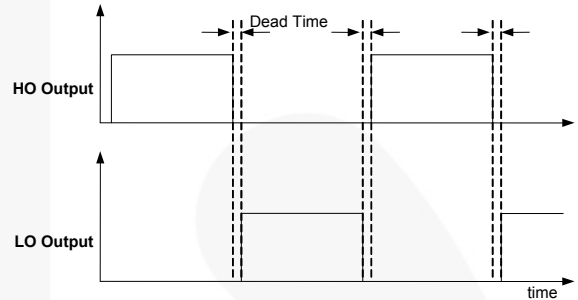

Figure 30. Gate Driving Signals

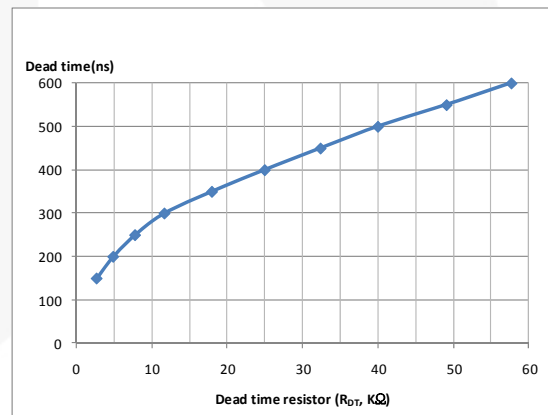

Figure 31. Dead Time vs.  $R_{DT}$

### 3. Soft-Start

Since the voltage gain of the resonant converter is inversely proportional to the switching frequency, the soft-start is implemented by sweeping down the switching frequency from a high initial frequency until the output voltage is established. The current-steering circuit connected to SS pin adaptively changes the sinking and sourcing current of the SS pin to set soft-start time, OLP shutdown delay, and restart time. As illustrated in Figure 32, the sourcing current,  $I_{SS1}$  (3mA), is enabled at the beginning of startup, which rapidly raises  $V_{SS}$  up to  $V_{SS\_START}$  (1.6V). Then the sourcing current is switched to  $I_{SS2}$  (30μA) and gate drive signals are enabled. Due to the small value of  $I_{SS2}$ , the SS pin voltage slowly rises, allowing slow decrease of the switching frequency.

To minimize the frequency variation while the output capacitance of the opto-transistor is charged up, soft-start is delayed until the CON pin voltage (opto-coupler transistor voltage) reaches the RT pin voltage. Thus, the

initial switching frequency is not affected by  $R_{max}$  and is solely determined as six times the minimum switching frequency set by  $R_{min}$  as in Equation (1). The maximum switching frequency is also internally limited at 600kHz.

When  $V_{SS}$  reaches  $V_{SS\_END}$  (4.2V), soft-start ends. Then, the high threshold of  $V_{CT}$  comparator,  $V_{TH}$ , is clamped at  $V_{SS\_END}$  while  $V_{SS}$  keeps increasing until it reaches  $V_{SSC}$  (5V). The soft-start time is given as:

$$t_{SS} = C_{SS} \frac{2.6}{3 \times 10^{-5}} \quad (2)$$

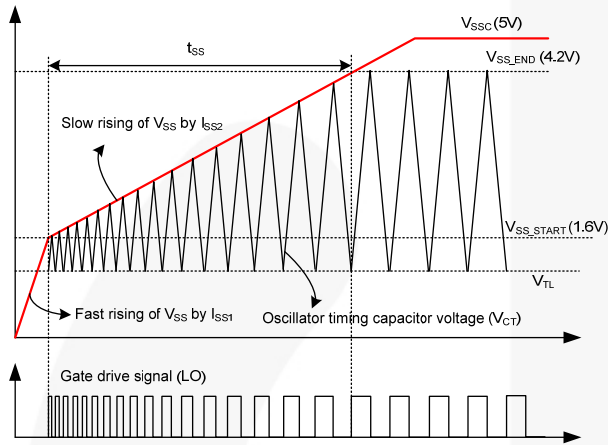

**Figure 32. Soft-Start Waveforms**

## 4. Current Sensing

FAN7631 employs a negative voltage sensing method to sense the drain current of the MOSFET. This allows sensing the current without a leading edge spike caused by the low-side MOSFET's driving current. Therefore, the resistive-sensing method requires only a small RC filter. The capacitive-sensing method is also available.

### 4.1. Resistive Sensing Method

The FAN7631 can sense the drain current as a negative voltage, as shown in Figure 33. An RC filter with a time constant of 1/30~1/10 of the operating period is typical.

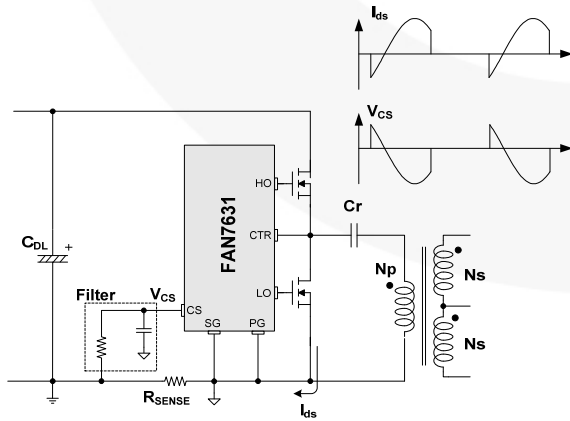

**Figure 33. Resistive Sensing**

### 4.2. Capacitive Sensing Method

The MOSFET drain current can be sensed using an additional capacitor in parallel with the resonant capacitor, as shown in Figure 34. While the low-side switch is turned on, the current,  $i_{CB}$ , through  $C_B$  introduces  $V_{SENSE}$  across  $R_{SENSE}$ . The  $i_{CB}$  is a fraction of the transformer primary-side current,  $i_p$ , determined by the current divider with capacitors  $C_r$  and  $C_B$  as:

$$i_{CB} = \frac{C_B}{C_r + C_B} i_p \cong \frac{C_B}{C_r} i_p \quad (3)$$

Generally, 1/100~1/1000 is adequate for the ratio of  $C_B/C_r$ .  $R_D$  is used as a damper for reducing noise generated by the switching transition. To prevent the damping resistor from affecting the current divider ratio, the resistor should be much smaller than the impedance of  $C_B$  at the switching frequency, calculated as:

$$R_D \ll \frac{1}{2\pi f_s C_B} \quad (4)$$

Then,  $V_{SENSE}$  can be obtained as:

$$V_{Sense} = \frac{C_B}{C_r} R_{sense} i_p \quad (5)$$

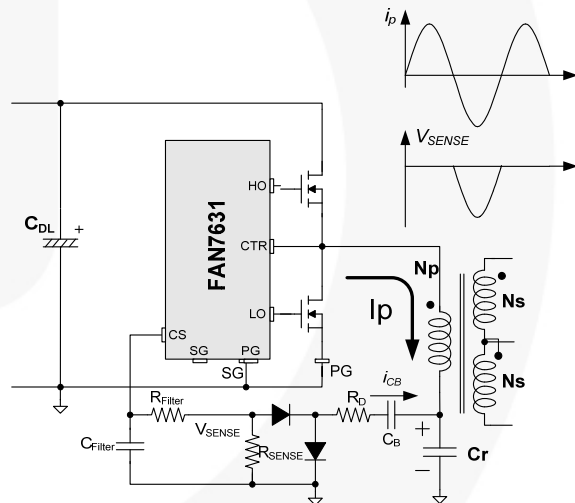

**Figure 34. Capacitive Sensing**

## 5. Protection Circuit

The FAN7631 has several self-protective functions: Overload Protection (OLP), Over-Current Protection (OCP), level-change OCP, Abnormal Over-Current Protection (AOCP), Over-Voltage Protection (OVP), Thermal Shutdown (TSD), Fault Input (FI), and Line Under-Voltage Lockout (LUVLO or also called brownout). Level-change OCP, OLP, OCP, OVP, and LUVLO are Auto-Restart Mode protections while AOCP, TSD, and fault input are Latch Mode protections.

Once auto-restart protection is triggered, switching is instantly terminated and the MOSFETs remain off. Then the FAN7631 keeps attempting to restart after the restart delay until the protection situation is removed. When a Latch Mode protection is triggered, the FAN7631 remains off until  $V_{CC}$  drops to  $V_{LR}$  (5V) and then rises above  $V_{CC,START}$  (12.5V).

### 5.1. Overload Protection (OLP)

When the sensed voltage on the CS pin drops below  $V_{OLP}$  (-0.37V) for more than OLP blanking time,  $t_{BOL}$  (200ns),  $C_{SS}$  starts to be discharged by sinking current  $I_{OLP}$ . If the sensed voltage on the CS pin does not drop below  $V_{OLP}$  in the next switching cycle, the current on the SS pin is switched to charging current  $I_{SS1}$ , restoring  $V_{SS}$  as illustrated in Figure 35. If the CS pin voltage drops below  $V_{OLP}$  for in next consecutive switching cycle until  $C_{SS}$  voltage,  $V_{SS}$ , reaches  $V_{SS\_START}$  (1.6V); OLP is triggered and the gate drive signals remain off. Once the OLP is triggered, FAN7631 repeats charging and discharging  $C_{SS}$  four times, then restarts. The OLP delay,  $t_{OLP}$ , and self auto-restart time,  $t_{AR}$ , are given as:

$$t_{OLP} = C_{SS} \frac{3.4}{3 \times 10^{-5}} \quad (6)$$

$$t_{AR} = 8 \times C_{SS} \frac{2.6}{3 \times 10^{-5}} \quad (7)$$

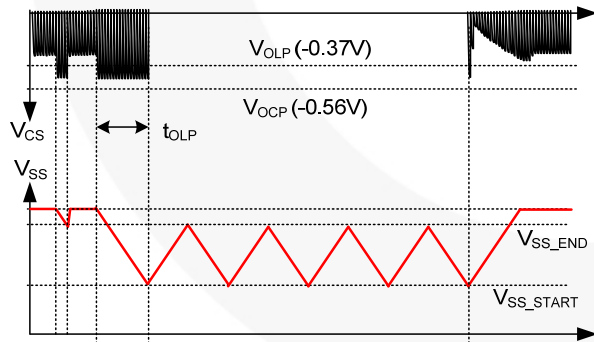

Figure 35. Overload Protection (OLP)

### 5.2. Over-Current Protection (OCP)

When the CS pin voltage drops below  $V_{OCP}$  (-0.54V) for longer than the OCP blanking time,  $t_{BO}$  (200ns), OCP is triggered, terminating switching operation. Then, FAN7631 repeats charging and discharging  $C_{SS}$  four times before restarting.

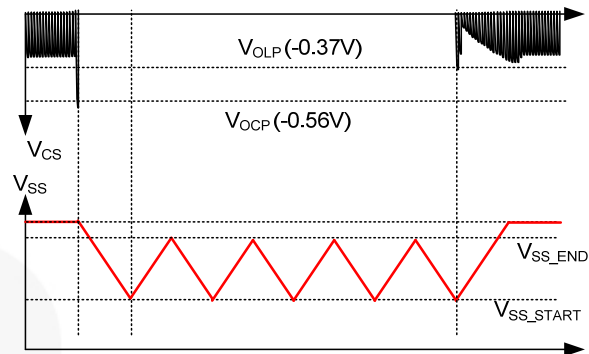

Figure 36. Over-Current Protection (OCP)

### 5.3. Abnormal Over-Current Protection (AOCP)

If the secondary-side rectifier diodes are shorted, a large current with extremely high di/dt can flow through the MOSFET before OCP is triggered. AOCP is triggered with a short blanking time of 50ns,  $t_{BAO}$ , when the sensed voltage drops below -1.10V, terminating the switching operation. Once the protection is triggered,  $V_{SS}$  is discharged by an internal switch. Since it is a Latch Mode protection, the protection is reset when  $V_{CC}$  drops to  $V_{LR}$  (5V).

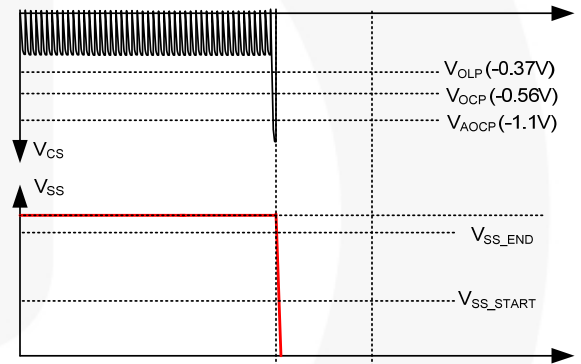

Figure 37. Abnormal Over-Current Protection (AOCP)

### 5.4. Level-Change Over-Current Protection (OCP)

Even with soft-start, there can be large overshoot current for the initial several switching cycles until the resonant capacitor voltage reaches its steady-state value. To prevent the startup failure by OCP, the OCP threshold is changed to  $V_{AOCP}$  level while the Latch Mode AOCP is disabled during soft-start.

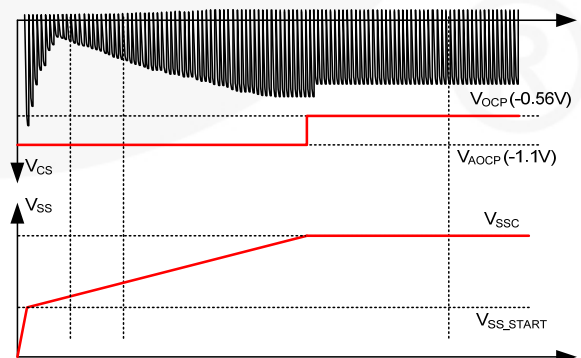

Figure 38. Level-Change OCP

### 5.5. Over-Voltage Protection (OVP)

When the  $V_{CC}$  reaches 23V, OVP is triggered. This protection is used when auxiliary winding of the transformer is utilized to supply  $V_{CC}$  to the FAN7631.

### 5.6. Thermal Shutdown (TSD)

The thermal shutdown function is integrated to detect abnormal over-temperature, such as abnormal ambient temperature rising or over-driving of gate drive circuit. If the junction temperature exceeds  $T_{SD}$  (130°C), thermal shutdown is triggered in Latch Mode.

### 5.7. Line-UVLO

FAN7631 includes a precise line-UVLO (or brownout) function with programmable hysteresis voltage, as can be seen in Figure 39. When the line voltage is recovered, it starts up with soft-start, as shown in Figure 39. A hysteresis voltage between the start and stop voltage is programmable by  $I_{LINE}$  and external resistor R1. In normal operation, the comparator's output is HIGH and  $I_{LINE}$  is disabled. When the comparator's output is LOW, introducing hysteresis.

If necessary,  $C_{Filter}$  can be used to reduce noise interference. Generally, hundreds of pico-farad to tens of nano-farad is adequate depending on the level of noise.

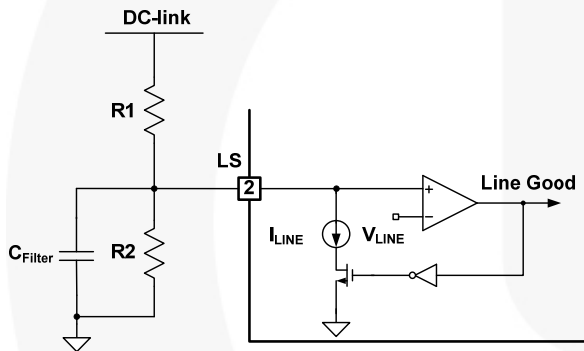

Figure 39. Line-UVLO

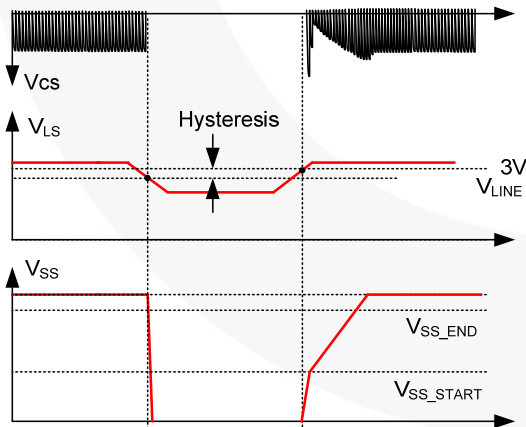

Figure 40. Line UVLO Waveforms

The DC link input-voltages for start and stop are calculated as:

$$V_{DL,STOP} = V_{LINE} \times \frac{R1 + R2}{R2} \quad (8)$$

$$V_{DL,START} = V_{DL,STOP} + I_{LINE} \times R1$$

### 6. Simple Remote-On/Off

The power stage can be shut down with Latch Mode or Auto-Restart Mode, as shown in Figure 41. For the Latch Mode protection, the FI pin is used, which stops the switching immediately once the voltage on FI pin is pulled above  $V_{FI}$  (4V) using an opto-coupler. To configure an external protection with Auto-Restart Mode, an opto-coupler can be used on the LS pin. When voltage on the LS pin is pulled below  $V_{LINE}$  (3V), line UVLO is triggered. When LS pin voltage is pulled HIGH, above 3V, FAN7631 starts up softly.

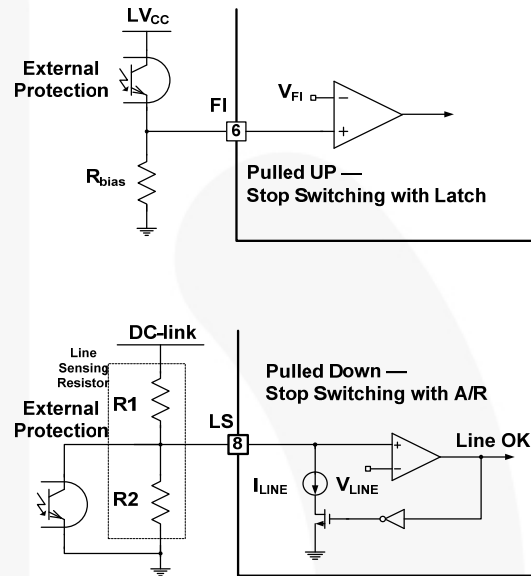

Figure 41. External Protection Circuits (Top: Latch Mode, Bottom: A/R Mode)

### 7. Skip Cycle Operation

The FAN7631 provides the pulse-skip function to prevent the switching frequency from increasing too much at no-load condition. Figure 42 shows the internal block diagram for the control (CON) pin and its external configuration. The CON pin is typically connected to the collector terminal of the opto-coupler and the FAN7631 stops switching when the CON pin voltage drops below 0.4V. FAN7631 resumes switching when the CON pin voltage rises above 0.6V. The frequency that causes pulse skipping is given as:

$$f_{SKIP} = \left( \frac{5.8k\Omega}{R_{min}} + \frac{4.6k\Omega}{R_{max}} \right) \times 100kHz \quad (9)$$

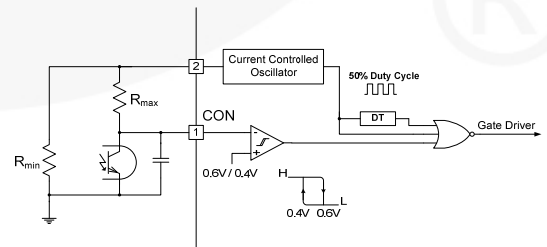

Figure 42. Pulse-Skipping Circuit

### 8. PCB Layout Guideline

Figure 43 shows the PCB layout guideline to minimize the usage of jumpers. Good PCB layout improves power system efficiency and reliability and minimizes EMI. The Power Ground (PG) and Signal Ground (SG) should meet at a single point. Jumpers should be avoided, especially for the ground trace.

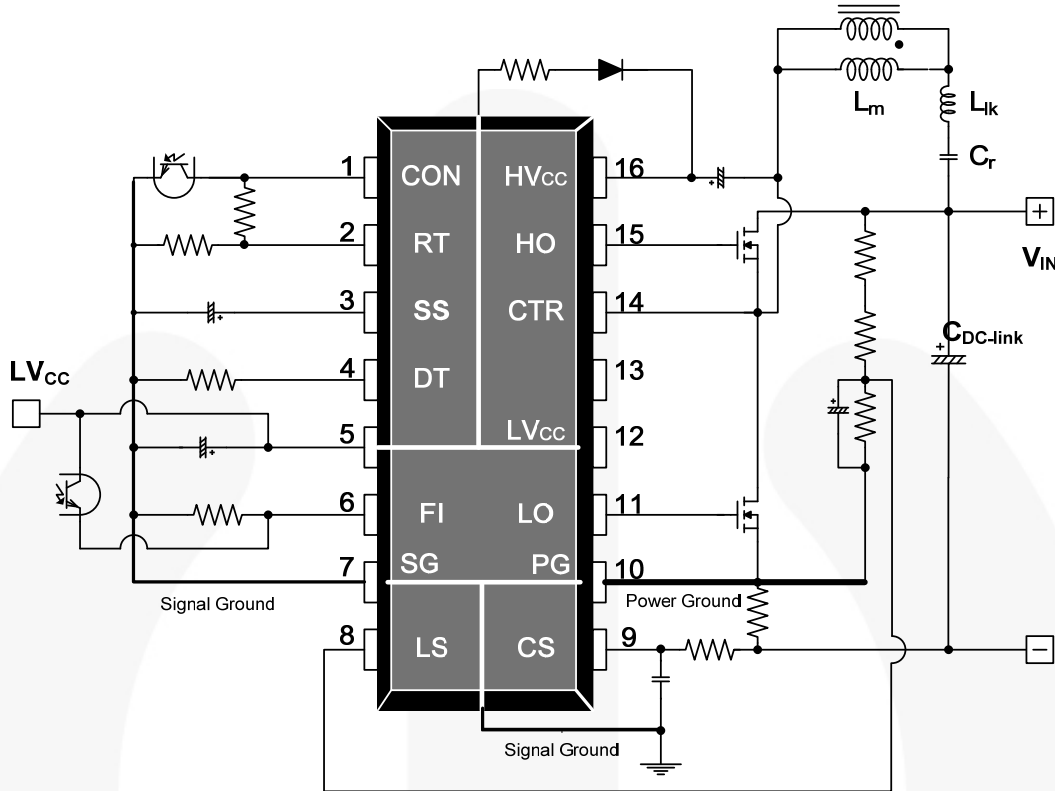

Figure 43. PCB Layout Guideline



### Typical Application Circuit (Half-Bridge LLC Resonant Converter)

Application	Fairchild Device	Input Voltage Range	Rated Output Power	Output Voltage (Rated Current)
LCD TV	FAN7631	400V (20ms Hold-Up Time)	192W	24V-8A

#### Features

- High efficiency (>94% at 400V<sub>DC</sub> input).
- Reduced EMI noise through zero-voltage-switching (ZVS).
- Enhanced system reliability with various protection functions.

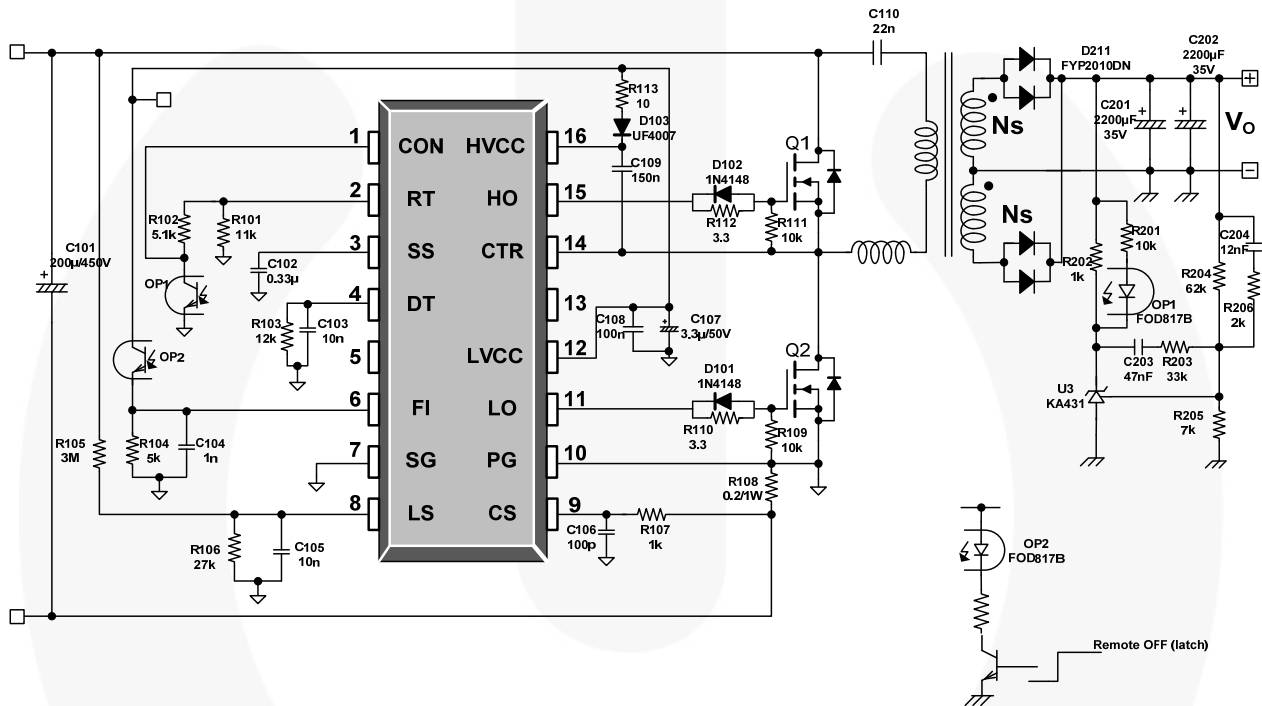

Figure 44. Typical Application Circuit

### Typical Application Circuit (Continued)

Usually, the LLC resonant converter requires large leakage inductance value. To obtain a large leakage inductance, sectional winding method is used.

- Core: EER3542 ( $A_e=107 \text{ mm}^2$ )
- Bobbin: EER3542 (Horizontal)

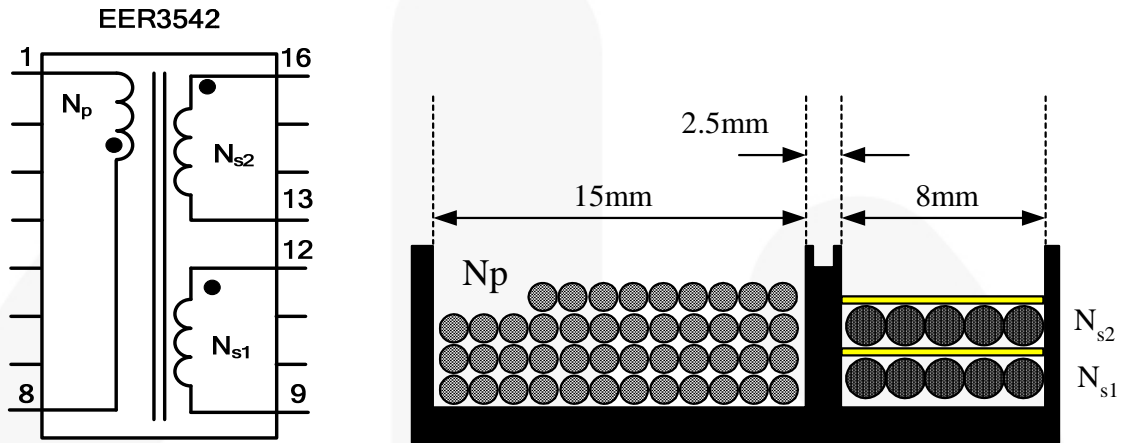

Figure 45. Winding Specifications

Table 1. Winding Specifications

	Pin (S → F)	Wire	Turns	Winding Method
$N_p$	8 → 1	0.12 $\phi$ ×30 (Litz Wire)	45	Section Winding
$N_{s1}$	12 → 9	0.1 $\phi$ ×100 (Litz Wire)	5	Section Winding
$N_{s2}$	16 → 13	0.1 $\phi$ ×100 (Litz Wire)	5	Section Winding

	Pin	Specification	Remark
Primary-Side Inductance ( $L_P$ )	1-8	630 $\mu$ H $\pm$ 5%	100kHz, 1V
Primary-Side Effective Leakage ( $L_R$ )	1-8	145 $\mu$ H $\pm$ 5%.	Short One of the Secondary Windings

### Physical Dimensions

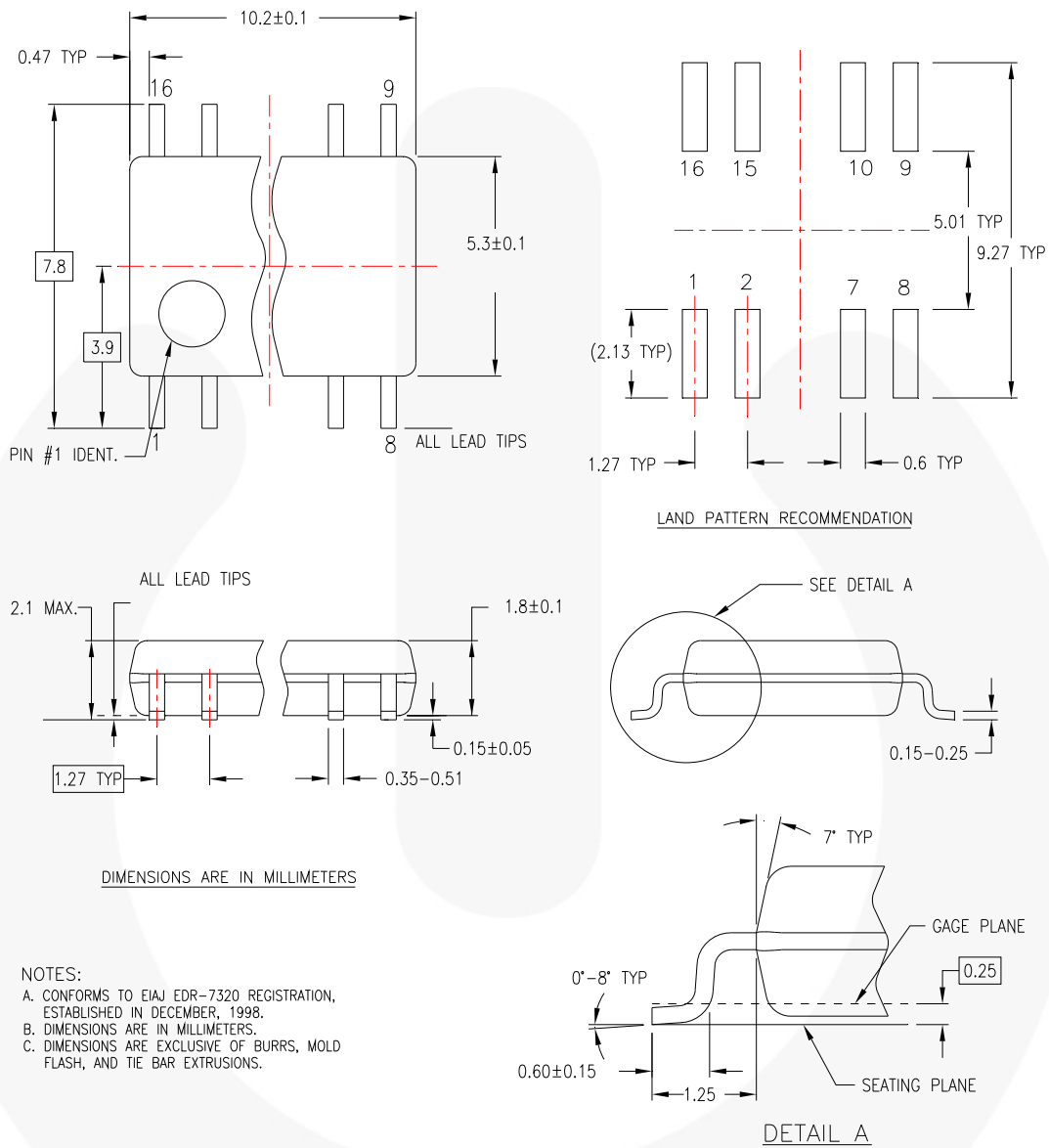

**Figure 46. 16-Lead, Small-Outline Package (SOP)**

Package drawings are provided as a service to customers considering Fairchild components. Drawings may change in any manner without notice. Please note the revision and/or date on the drawing and contact a Fairchild Semiconductor representative to verify or obtain the most recent revision. Package specifications do not expand the terms of Fairchild's worldwide terms and conditions, specifically the warranty therein, which covers Fairchild products.

Always visit Fairchild Semiconductor's online packaging area for the most recent package drawings:  
<http://www.fairchildsemi.com/packaging/>



**TRADEMARKS**

The following includes registered and unregistered trademarks and service marks, owned by Fairchild Semiconductor and/or its global subsidiaries, and is not intended to be an exhaustive list of all such trademarks.

- |  |  |  |  |
|--|--|--|--|
| 2Cool™   | F-PFS™   | PowerTrench®   | The Power Franchise®   |
| AccuPower™   | FRFET®   | PowerXS™   | the power franchise  |
| AX-CAP™*   | Global Power Resource <sup>SM</sup>            | Programmable Active Droop™   | TinyBoost™   |
| BitSiC™  | GreenBridge™                                   | QFET®  | TinyBuck™  |
| Build it Now™  | Green FPS™                                     | QS™  | TinyCalc™  |
| CorePLUS™  | Green FPS™ e-Series™                           | Quiet Series™  | TinyLogic®   |
| CorePOWER™   | Gmax™  | RapidConfigure™  | TINYOPTO™  |
| CROSSVOLT™   | GTO™   |  ™                | TinyPower™   |
| CTL™   | IntelliMAX™                                    | Saving our world, 1mW/W/kW at a time™  | TinyPWM™   |
| Current Transfer Logic™  | ISOPLANAR™                                     | SignalWise™  | TinyWire™  |
| DEUXPEED®  | Making Small Speakers Sound Louder and Better™ | SmartMax™  | TransiC™   |
| Dual Cool™   | MegaBuck™                                      | SMART START™   | TriFault Detect™   |
| EcoSPARK®  | MICROCOUPLER™                                  | Solutions for Your Success™  | TRUECURRENT®*  |
| EfficientMax™  | MicroFET™                                      | SPM®   | µSerDes™   |
| ESBC™  | MicroPak™                                      | STEALTH™   |  SerDes |
|  Fairchild® | MicroPak2™                                     | SuperFET®  | UHC™   |
| Fairchild Semiconductor®   | MillerDrive™                                   | SuperSOT™-3  | Ultra FRFET™   |
| FACT Quiet Series™   | MotionMax™                                     | SuperSOT™-6  | UniFET™  |
| FACT®  | Motion-SPM™                                    | SuperSOT™-8  | VCX™   |
| FAST®  | mWSaver™                                       | SupreMOS®  | VisualMax™   |
| FastvCore™   | OptoHiT™                                       | SyncFET™   | VoltagePlus™   |
| FETBench™  | OPTOLOGIC®                                     | Sync-Lock™   | XS™  |
| FlashWriter®*  | OPTOPLANAR®                                    |  SYSTEM GENERAL®* |  |
| FPS™   |  |  |  |

\* Trademarks of System General Corporation, used under license by Fairchild Semiconductor.

**DISCLAIMER**

FAIRCHILD SEMICONDUCTOR RESERVES THE RIGHT TO MAKE CHANGES WITHOUT FURTHER NOTICE TO ANY PRODUCTS HEREIN TO IMPROVE RELIABILITY, FUNCTION, OR DESIGN. FAIRCHILD DOES NOT ASSUME ANY LIABILITY ARISING OUT OF THE APPLICATION OR USE OF ANY PRODUCT OR CIRCUIT DESCRIBED HEREIN; NEITHER DOES IT CONVEY ANY LICENSE UNDER ITS PATENT RIGHTS, NOR THE RIGHTS OF OTHERS. THESE SPECIFICATIONS DO NOT EXPAND THE TERMS OF FAIRCHILD'S WORLDWIDE TERMS AND CONDITIONS, SPECIFICALLY THE WARRANTY THEREIN, WHICH COVERS THESE PRODUCTS.

**LIFE SUPPORT POLICY**

FAIRCHILD'S PRODUCTS ARE NOT AUTHORIZED FOR USE AS CRITICAL COMPONENTS IN LIFE SUPPORT DEVICES OR SYSTEMS WITHOUT THE EXPRESS WRITTEN APPROVAL OF FAIRCHILD SEMICONDUCTOR CORPORATION.

As used herein:

1. Life support devices or systems are devices or systems which, (a) are intended for surgical implant into the body or (b) support or sustain life, and (c) whose failure to perform when properly used in accordance with instructions for use provided in the labeling, can be reasonably expected to result in a significant injury of the user.
2. A critical component in any component of a life support, device, or system whose failure to perform can be reasonably expected to cause the failure of the life support device or system, or to affect its safety or effectiveness.

**ANTI-COUNTERFEITING POLICY**

Fairchild Semiconductor Corporation's Anti-Counterfeiting Policy. Fairchild's Anti-Counterfeiting Policy is also stated on our external website, [www.fairchildsemi.com](http://www.fairchildsemi.com), under Sales Support.

Counterfeiting of semiconductor parts is a growing problem in the industry. All manufacturers of semiconductor products are experiencing counterfeiting of their parts. Customers who inadvertently purchase counterfeit parts experience many problems such as loss of brand reputation, substandard performance, failed applications, and increased cost of production and manufacturing delays. Fairchild is taking strong measures to protect ourselves and our customers from the proliferation of counterfeit parts. Fairchild strongly encourages customers to purchase Fairchild parts either directly from Fairchild or from Authorized Fairchild Distributors who are listed by country on our web page cited above. Products customers buy either from Fairchild directly or from Authorized Fairchild Distributors are genuine parts, have full traceability, meet Fairchild's quality standards for handling and storage and provide access to Fairchild's full range of up-to-date technical and product information. Fairchild and our Authorized Distributors will stand behind all warranties and will appropriately address any warranty issues that may arise. Fairchild will not provide any warranty coverage or other assistance for parts bought from Unauthorized Sources. Fairchild is committed to combat this global problem and encourage our customers to do their part in stopping this practice by buying direct or from authorized distributors.

**PRODUCT STATUS DEFINITIONS**

**Definition of Terms**

Datasheet Identification	Product Status	Definition
Advance Information	Formative / In Design	Datasheet contains the design specifications for product development. Specifications may change in any manner without notice.
Preliminary	First Production	Datasheet contains preliminary data; supplementary data will be published at a later date. Fairchild Semiconductor reserves the right to make changes at any time without notice to improve design.
No Identification Needed	Full Production	Datasheet contains final specifications. Fairchild Semiconductor reserves the right to make changes at any time without notice to improve the design.
Obsolete	Not In Production	Datasheet contains specifications on a product that is discontinued by Fairchild Semiconductor. The datasheet is for reference information only.

Rev. 161

ON Semiconductor and  are trademarks of Semiconductor Components Industries, LLC dba ON Semiconductor or its subsidiaries in the United States and/or other countries. ON Semiconductor owns the rights to a number of patents, trademarks, copyrights, trade secrets, and other intellectual property. A listing of ON Semiconductor's product/patent coverage may be accessed at [www.onsemi.com/site/pdf/Patent-Marking.pdf](http://www.onsemi.com/site/pdf/Patent-Marking.pdf). ON Semiconductor reserves the right to make changes without further notice to any products herein. ON Semiconductor makes no warranty, representation or guarantee regarding the suitability of its products for any particular purpose, nor does ON Semiconductor assume any liability arising out of the application or use of any product or circuit, and specifically disclaims any and all liability, including without limitation special, consequential or incidental damages. Buyer is responsible for its products and applications using ON Semiconductor products, including compliance with all laws, regulations and safety requirements or standards, regardless of any support or applications information provided by ON Semiconductor. "Typical" parameters which may be provided in ON Semiconductor data sheets and/or specifications can and do vary in different applications and actual performance may vary over time. All operating parameters, including "Typicals" must be validated for each customer application by customer's technical experts. ON Semiconductor does not convey any license under its patent rights nor the rights of others. ON Semiconductor products are not designed, intended, or authorized for use as a critical component in life support systems or any FDA Class 3 medical devices or medical devices with a same or similar classification in a foreign jurisdiction or any devices intended for implantation in the human body. Should Buyer purchase or use ON Semiconductor products for any such unintended or unauthorized application, Buyer shall indemnify and hold ON Semiconductor and its officers, employees, subsidiaries, affiliates, and distributors harmless against all claims, costs, damages, and expenses, and reasonable attorney fees arising out of, directly or indirectly, any claim of personal injury or death associated with such unintended or unauthorized use, even if such claim alleges that ON Semiconductor was negligent regarding the design or manufacture of the part. ON Semiconductor is an Equal Opportunity/Affirmative Action Employer. This literature is subject to all applicable copyright laws and is not for resale in any manner.

## PUBLICATION ORDERING INFORMATION

### LITERATURE FULFILLMENT:

Literature Distribution Center for ON Semiconductor  
19521 E. 32nd Pkwy, Aurora, Colorado 80011 USA  
**Phone:** 303-675-2175 or 800-344-3860 Toll Free USA/Canada  
**Fax:** 303-675-2176 or 800-344-3867 Toll Free USA/Canada  
**Email:** [orderlit@onsemi.com](mailto:orderlit@onsemi.com)

**N. American Technical Support:** 800-282-9855 Toll Free  
USA/Canada  
**Europe, Middle East and Africa Technical Support:**  
Phone: 421 33 790 2910  
**Japan Customer Focus Center**  
Phone: 81-3-5817-1050

**ON Semiconductor Website:** [www.onsemi.com](http://www.onsemi.com)  
**Order Literature:** <http://www.onsemi.com/orderlit>  
For additional information, please contact your local  
Sales Representative

# Mouser Electronics

Authorized Distributor

Click to View Pricing, Inventory, Delivery & Lifecycle Information:

[ON Semiconductor:](#)

[FAN7631SJX](#) [FAN7631SJ](#)



Компания «ЭлектроПласт» предлагает заключение долгосрочных отношений при поставках импортных электронных компонентов на взаимовыгодных условиях!

Наши преимущества:

- Оперативные поставки широкого спектра электронных компонентов отечественного и импортного производства напрямую от производителей и с крупнейших мировых складов;
- Поставка более 17-ти миллионов наименований электронных компонентов;
- Поставка сложных, дефицитных, либо снятых с производства позиций;
- Оперативные сроки поставки под заказ (от 5 рабочих дней);
- Экспресс доставка в любую точку России;
- Техническая поддержка проекта, помощь в подборе аналогов, поставка прототипов;
- Система менеджмента качества сертифицирована по Международному стандарту ISO 9001;
- Лицензия ФСБ на осуществление работ с использованием сведений, составляющих государственную тайну;
- Поставка специализированных компонентов (Xilinx, Altera, Analog Devices, Intersil, Interpoint, Microsemi, Aeroflex, Peregrine, Syfer, Eurofarad, Texas Instrument, Miteq, Cobham, E2V, MA-COM, Hittite, Mini-Circuits, General Dynamics и др.);

Помимо этого, одним из направлений компании «ЭлектроПласт» является направление «Источники питания». Мы предлагаем Вам помощь Конструкторского отдела:

- Подбор оптимального решения, техническое обоснование при выборе компонента;
- Подбор аналогов;
- Консультации по применению компонента;
- Поставка образцов и прототипов;
- Техническая поддержка проекта;
- Защита от снятия компонента с производства.



#### Как с нами связаться

**Телефон:** 8 (812) 309 58 32 (многоканальный)

**Факс:** 8 (812) 320-02-42

**Электронная почта:** [org@eplast1.ru](mailto:org@eplast1.ru)

**Адрес:** 198099, г. Санкт-Петербург, ул. Калинина, дом 2, корпус 4, литера А.