



PAM8007

Filterless 3W Class-D Stereo Audio Amplifier with DC Volume Control and Headphone Output

Key Features

- 3W Output at 10% THD with a 4Ω Load and 5V Power Supply
- Filterless, Low Quiescent Current and Low EMI
- Low THD+N
- 64-step DC Volume Control
- Headphone Output Function
- Superior Low Noise
- Low pop noise
- Efficiency up to 92%
- Short Circuit Protection
- Thermal Shutdown
- Few External Components to Save the Space and Cost
- Pb-Free Package

Applications

- LCD Monitors / TV Projectors
- Notebook Computers
- Portable Speakers
- Portable DVD Players, Game Machines
- VoIP/Speaker Phones

General Description

The PAM8007 is a 3W, class-D audio amplifier with headphone amplifier. Advanced 64-step DC volume control minimizes external components and allows speaker volume control and headphone volume control. It offers low THD+N, to produce high-quality sound reproduction. The new filterless architecture allows the device to drive the speaker directly, without low-pass output filters, which will save 30% system cost and 75% PCB area.

With the same numbers of external components, the efficiency of the PAM8007 is much better than class-AB cousins. It can extend the battery life thus be ideal for portable applications.

The PAM8007 is available in a SSOP-24 and SOP-24 package.

Typical Application

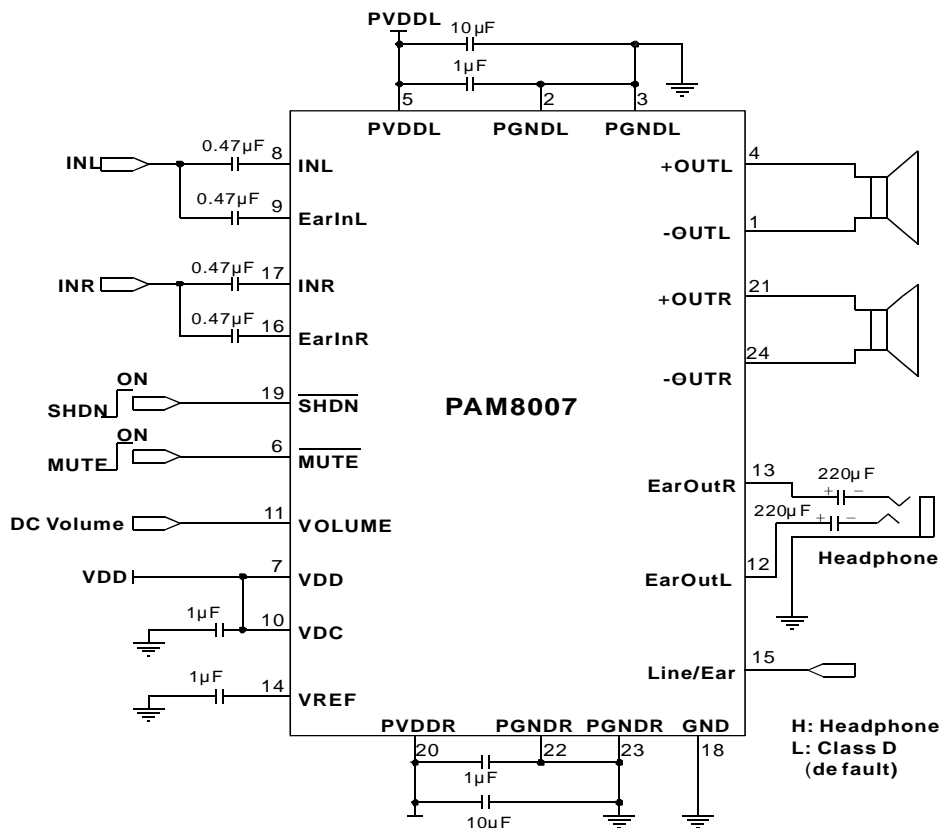



PAM8007

Filterless 3W Class-D Stereo Audio Amplifier with DC Volume Control and Headphone Output

Block Diagram

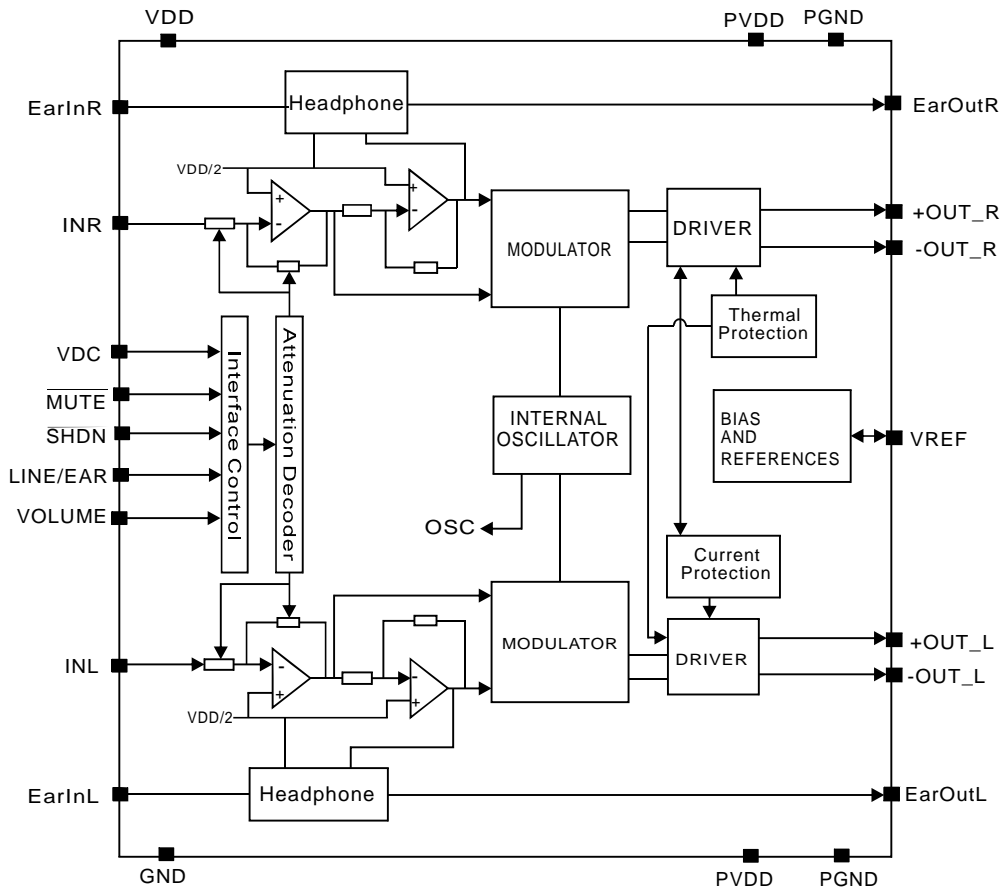

Pin Configuration & Marking Information

SSOP24
Top View

SOP24
Top View

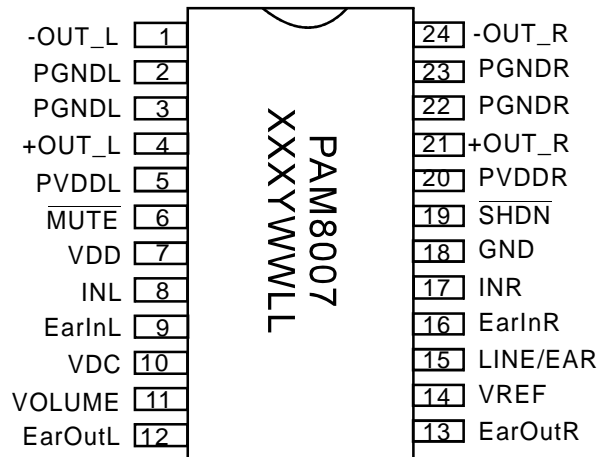
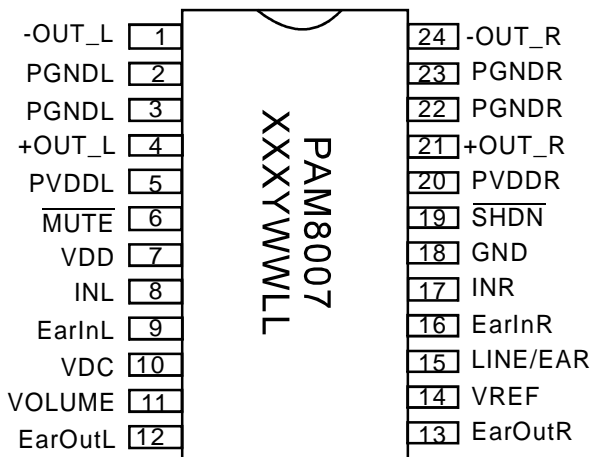

X: Internal Code
Y: Year
WW: Week
LL: Internal Code

Power Analog Microelectronics, Inc



PAM8007

Filterless 3W Class-D Stereo Audio Amplifier with DC Volume Control and Headphone Output

Electrical Characteristic

$V_{DD}=5V$, Gain = 24dB, $R_L=8\Omega$, $T_A=25^\circ C$, unless otherwise noted.

PARAMETER	SYMBOL	CONDITIONS	MIN	TYP	MAX	UNITS
Class D Stage						
Supply Voltage Range	V_{DD}		2.5		5.5	V
Quiescent Current	I_Q	No Load		12	16	mA
Output Offset Voltage	V_{OS}	No Load		10	50	mV
Drain-Source On-State Resistance	$R_{DS(ON)}$	$I_{DS}=0.5A$	P MOSFET	0.23		Ω
			N MOSFET	0.17		
Output Power	P_O	THD+N=10%, $f=1kHz$	$R_L=8\Omega$	1.55	1.75	W
			$R_L=4\Omega$	2.85	3.1	
Total Harmonic Distortion Plus Noise	THD+N	$R_L=8\Omega, P_O=1W, f=1kHz$		0.12		%
		$R_L=4\Omega, P_O=2W, f=1kHz$		0.15		
Power Supply Ripple Rejection	PSRR	Input AC-GND, $f=1kHz, V_{pp}=200mV$		63		dB
Channel Separation	CS	$V_o=1V_{rms}, f=1kHz$		-88		dB
Oscillator Frequency	f_{osc}		200	250	300	kHz
Efficiency	η	$P_O=1.75W, f=1kHz, R_L=8\Omega$	85	92		%
		$P_O=3.0W, f=1kHz, R_L=4\Omega$	80	88		%
Noise	V_n	Input AC-GND Gain=12dB	A-weighting	65		μV
			No A-weighting	90		
Signal Noise Ratio	SNR	$f=20-20kHz, THD=1\%$		84		dB
Earphone Stage						
Output Power	P_O	THD+N=1%, $R_L=32\Omega, f=1kHz$		69		mW
Total Harmonic Distortion Plus Noise	THD+N	$R_L=32\Omega, P_O=10mW, f=1kHz$		0.04		%
Power Supply Ripple Rejection	PSRR	Input AC-GND, $f=1kHz, V_{pp}=200mV$		73		dB
Channel Separation	CS	$V_o=1V_{rms}, f=1kHz$		95		dB
Noise	V_n	Input AC-GND	A-weighting	19		μV
			No A-weighting	25		
Signal Noise Ratio	SNR	$f=20-20kHz, THD=1\%$		97		dB
Control Section						
Mute Current	I_{MUTE}	$V_{MUTE}=0V$		8	12	mA
Shutdown Current	I_{SHDN}	$V_{SHDN}=0V$			20	μA
\overline{SHDN} Input High	V_{SH}		1.5			V
\overline{SHDN} Input Low	V_{SL}			0.4		
\overline{MUTE} Input High	V_{MH}		1.5			V
\overline{MUTE} Input Low	V_{ML}			0.4		
Line/Ear Input High	V_{DH}		2.5			V
Line/Ear Input Low	V_{DL}			0.4		
Over Temperature Protection	OTP			150		$^\circ C$
Over Temperature Hysteresis	OTH			30		$^\circ C$

Typical Operating Characteristics ($T_A=25^\circ\text{C}$)

Speaker

1. THD+N vs Output Power

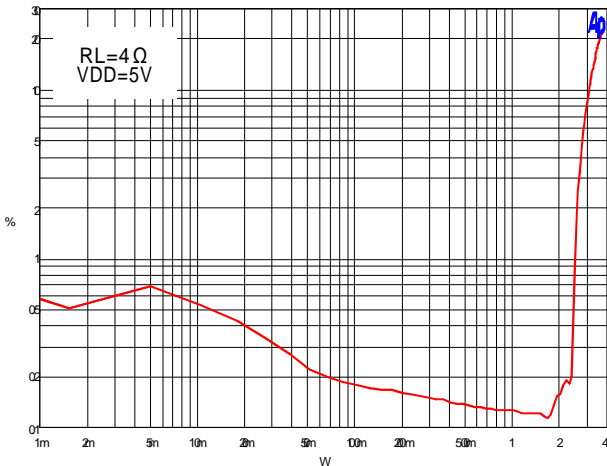

2. THD+N vs Output Power

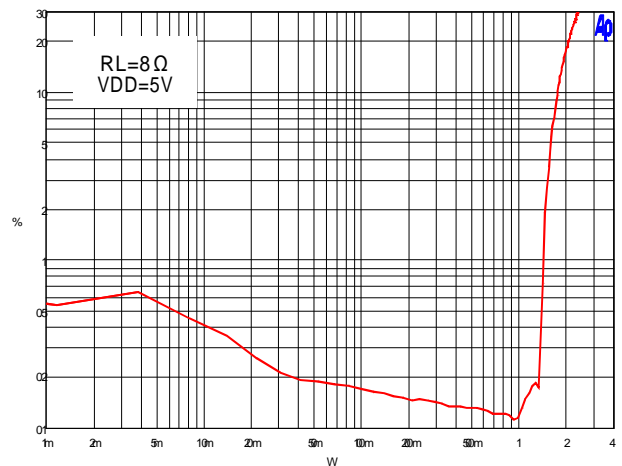

3. THD+N vs Frequency

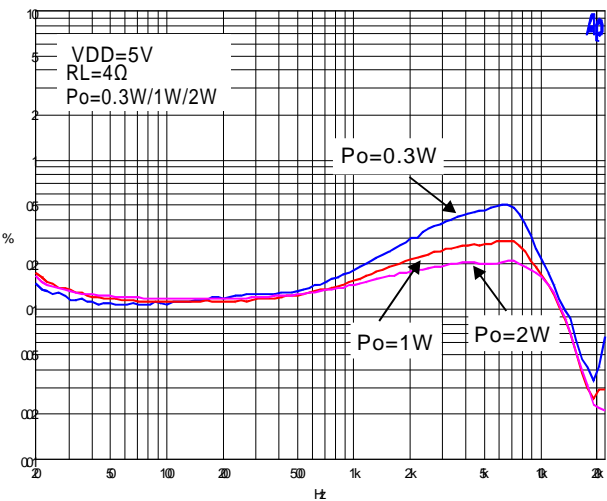

4. THD+N vs Frequency

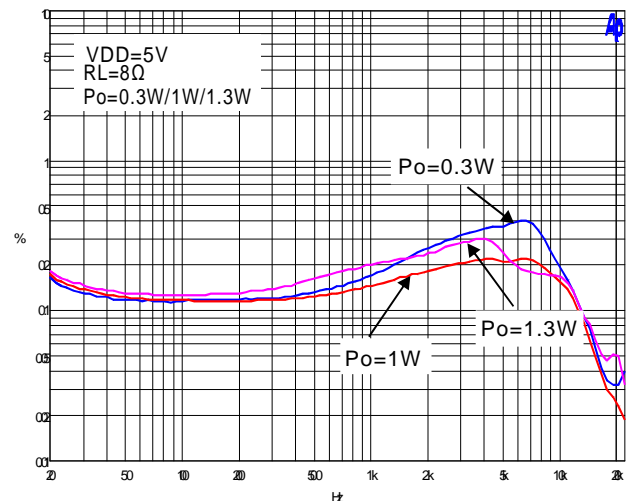

5. PSRR vs Frequency

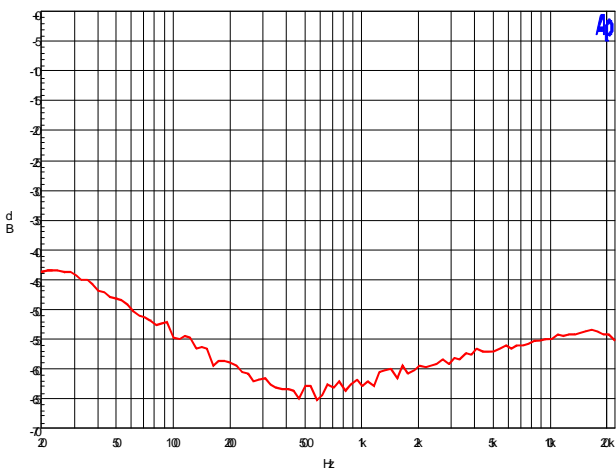

6. Crosstalk vs Frequency

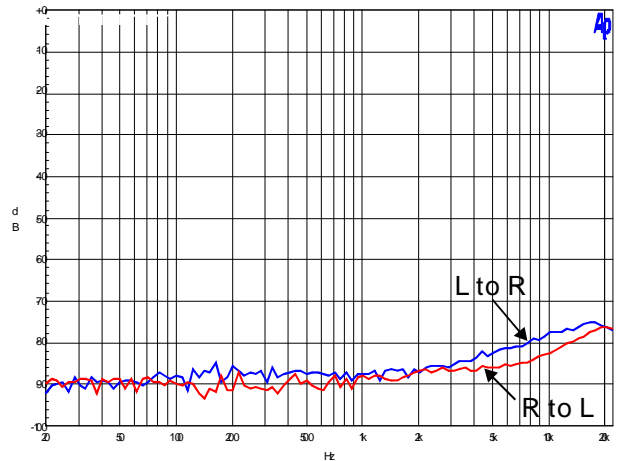

Typical Operating Characteristics ($T_A=25^\circ\text{C}$)

Speaker

7. Frequency Response

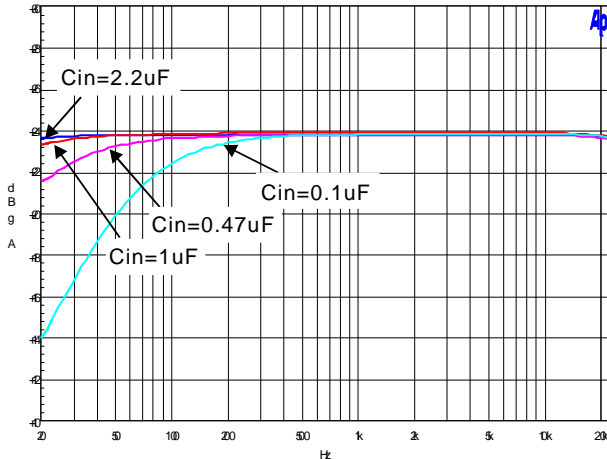

8. Noise Floor

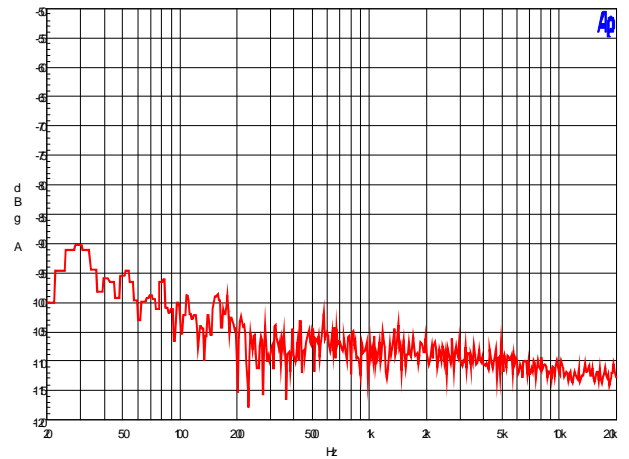

9. Power Dissipation vs Output Power

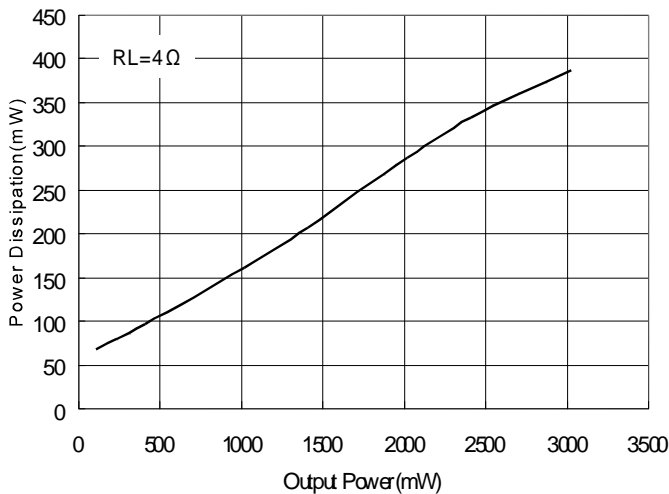

10. Power Dissipation vs Output Power

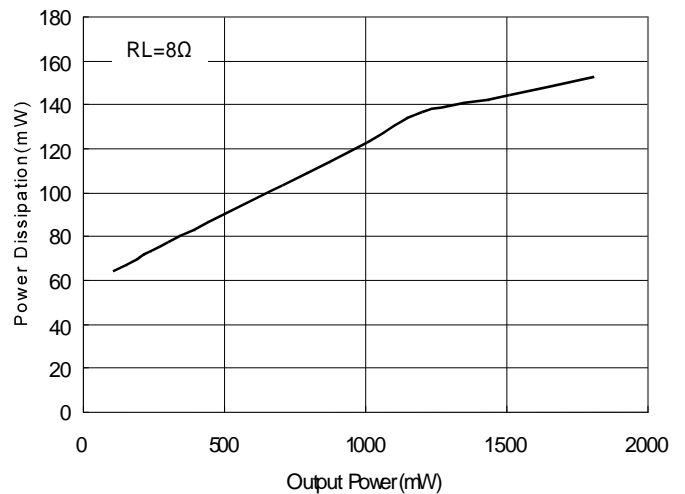

11. Efficiency vs Output Power

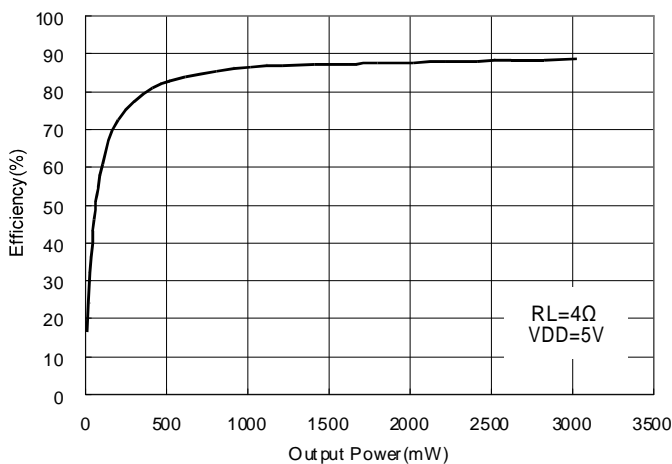

12. Efficiency vs Output Power

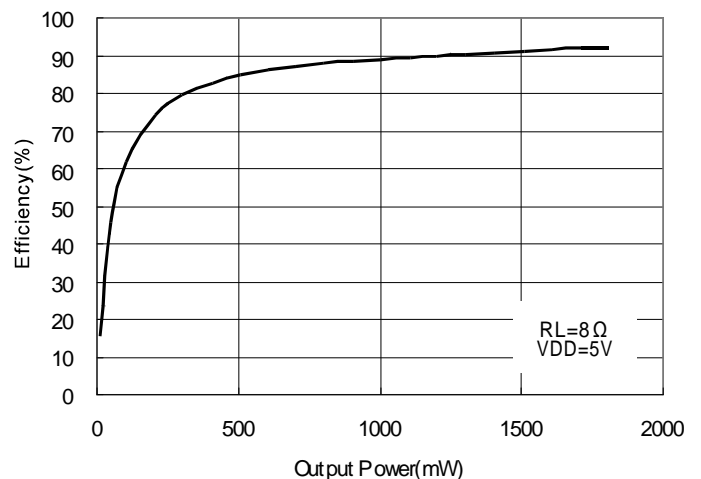



Typical Operating Characteristics ($T_A=25^\circ\text{C}$)

Speaker

13. Output Power VS Supply Voltage

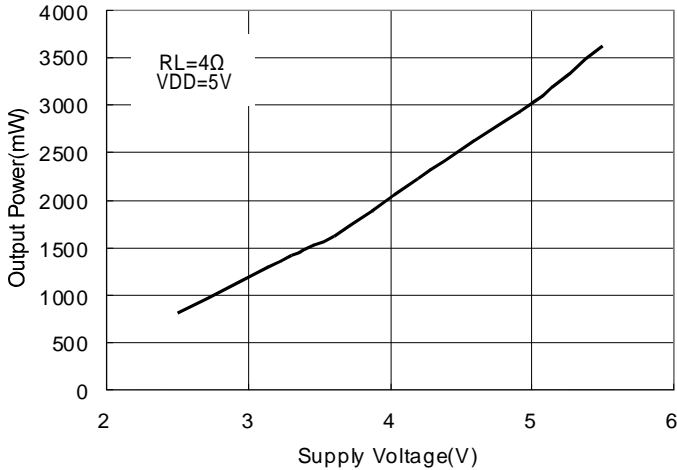

14. Output Power VS Supply Voltage

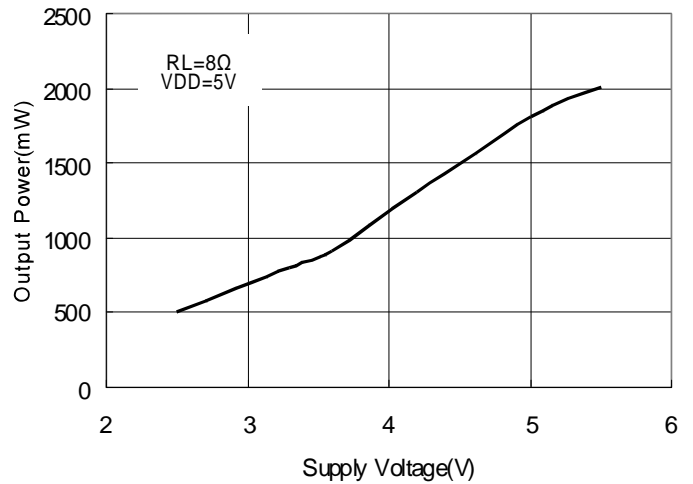

15. Rdson VS Output Current

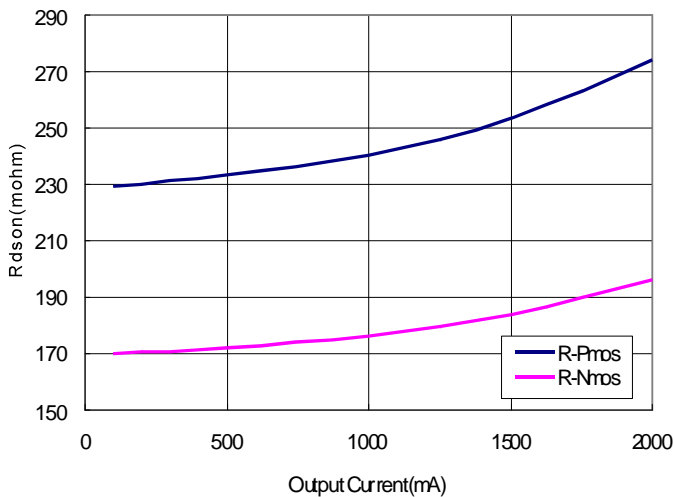

16. Quiescent Current



17. Switching Frequency VS Supply Voltage

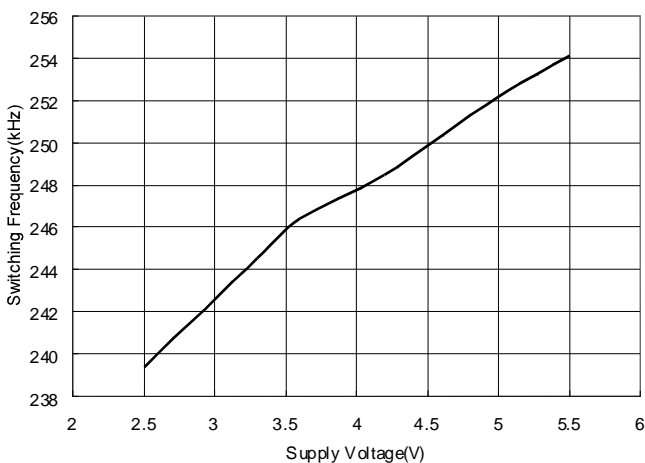

18. Gain Step

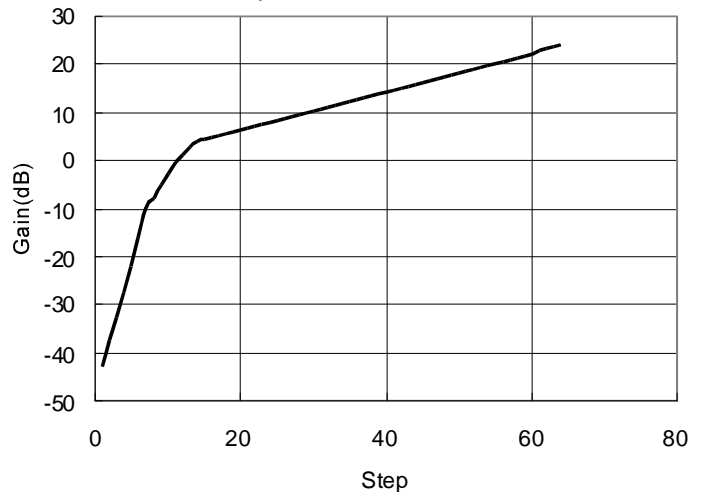



Typical Operating Characteristics (continued)

Earphone Output

1. THD+N vs Output Power

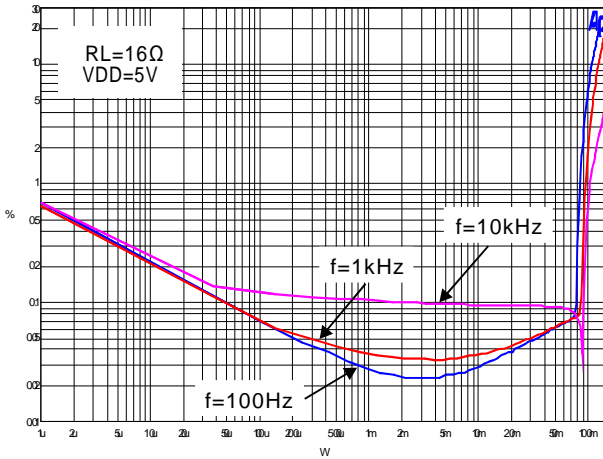

2. THD+N vs Output Power

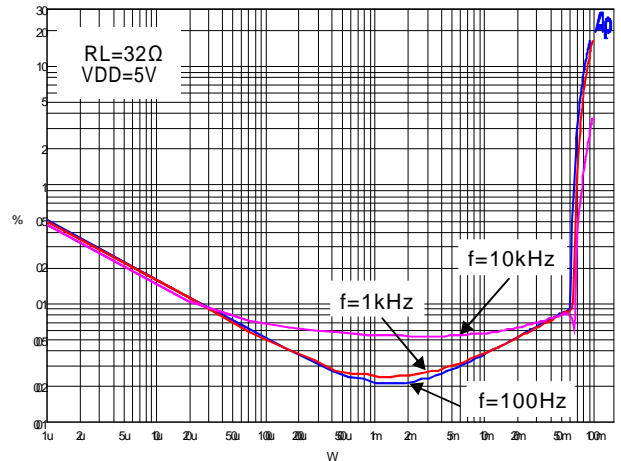

3. THD+N vs Frequency

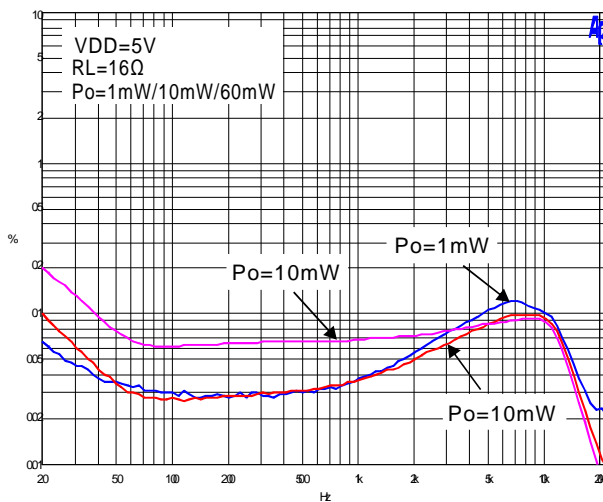

4. THD+N vs Frequency

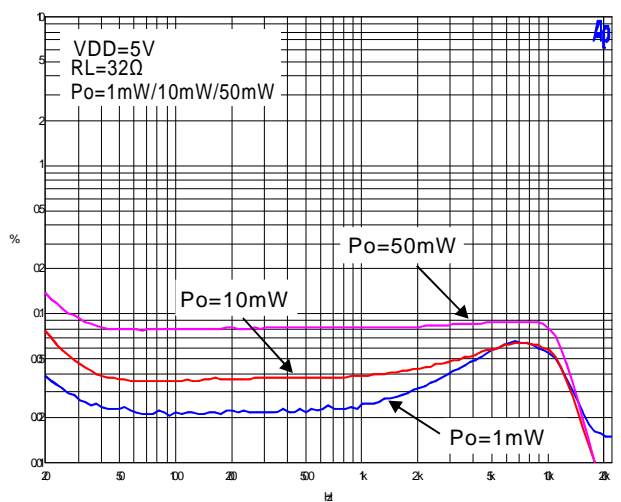

5. PSRR vs Frequency

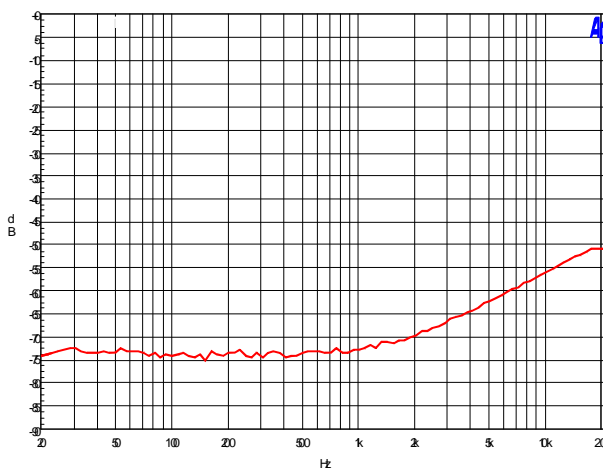

6. Crosstalk vs Frequency

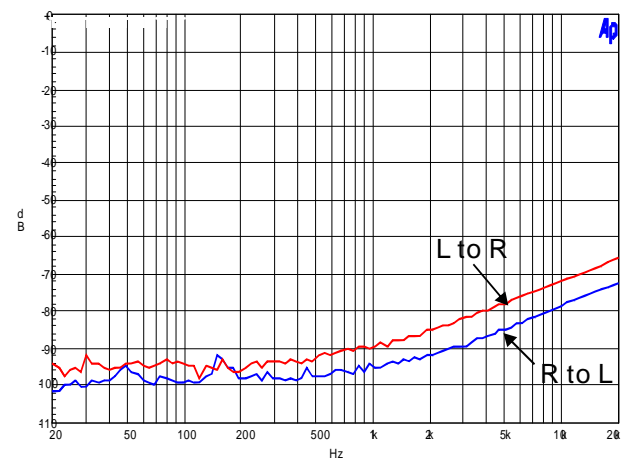



Typical Operating Characteristics ($T_A=25^\circ\text{C}$)

7. Frequency Response

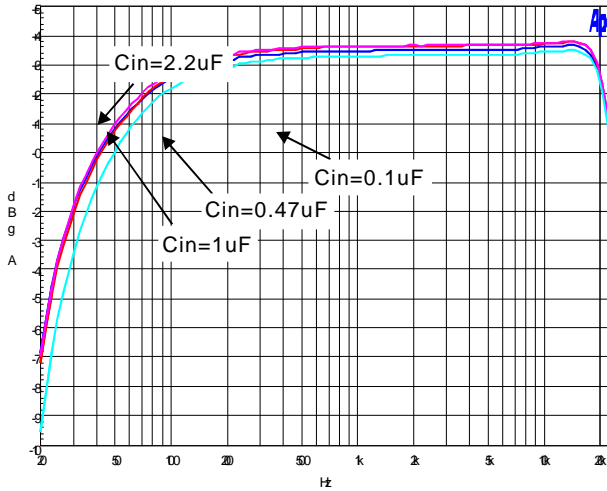

8. Noise Floor

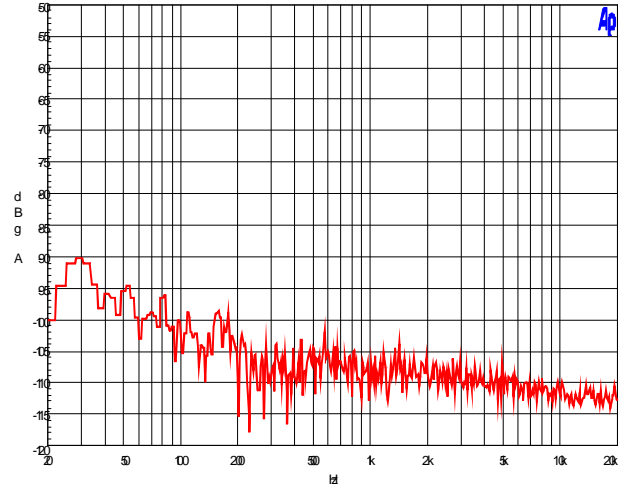

9. Gain Step

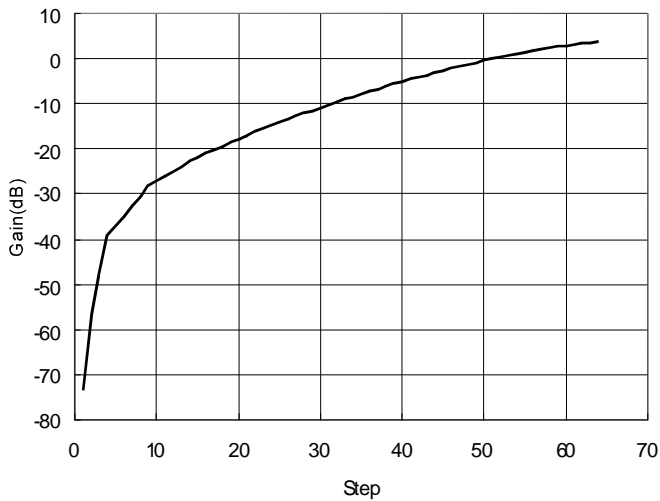



Typical Operating Characteristics (continued)

Table 1. DC Volume Control

STEP	Gain(dB) Class D	Gain(dB) Earphone	STEP	Gain(dB) Class D	Gain(dB) Earphone
1	-80	-80	33	11.6	-9.2
2	-40	-60	34	12	-8.6
3	-34	-50	35	12.4	-8
4	-28	-40	36	12.8	-7.4
5	-22	-37.7	37	13.2	-6.8
6	-16	-35.4	38	13.6	-6.2
7	-10	-33.1	39	14	-5.7
8	-7.5	-30.8	40	14.4	-5.2
9	-5	-28.5	41	14.8	-4.7
10	-2.5	-27.5	42	15.2	-4.2
11	0	-26.4	43	15.6	-3.7
12	1.5	-25.3	44	16	-3.2
13	3	-24.2	45	16.4	-2.7
14	4	-23.1	46	16.8	-2.2
15	4.4	-22.2	47	17.2	-1.8
16	4.8	-21.4	48	17.6	-1.4
17	5.2	-20.6	49	18	-1
18	5.6	-19.8	50	18.4	-0.6
19	6	-19	51	18.8	-0.2
20	6.4	-18.2	52	19.2	0.2
21	6.8	-17.4	53	19.6	0.6
22	7.2	-16.6	54	20	0.9
23	7.6	-15.9	55	20.4	1.2
24	8	-15.2	56	20.8	1.5
25	8.4	-14.5	57	21.2	1.8
26	8.8	-13.8	58	21.6	2.1
27	9.2	-13.1	59	22	2.4
28	9.6	-12.4	60	22.4	2.7
29	10	-11.7	61	22.8	2.9
30	10.4	-11	62	23.2	3.1
31	10.8	-10.4	63	23.6	3.3
32	11.2	-9.8	64	24	3.5

Test Setup for Performance Testing(Class D)

Application Notice

1. When the PAM8007 works with LC filters, it should be connected with the speaker before it's powered on, otherwise it will be damaged easily.
2. When the PAM8007 works without LC filters, it's better to add a ferrite chip bead at the outgoing line of speaker for suppressing the possible electromagnetic interference.
3. The absolute maximum rating of the PAM8007 operation voltage is 6.0V. When the PAM8007 is powered with 4 battery cells, it should be noted that the voltage of 4 new dry or alkaline batteries is over 6V, higher than its maximum operation voltage, which probably

make the device damaged. Therefore, it's recommended to use either 4 Ni-MH (Nickel Metal Hydride) rechargeable batteries or 3 dry or alkaline batteries.

4. The input signal should not be too high, if too high, it will cause the clipping of output signal when increasing the volume. Because the DC volume control of the PAM8007 has big gain, it will make the device damaged.

5. When testing the PAM8007 without LC filters by using resistor instead of speaker as the output load, the test results, e.g. THD or efficiency, will be worse than those using speaker as load.

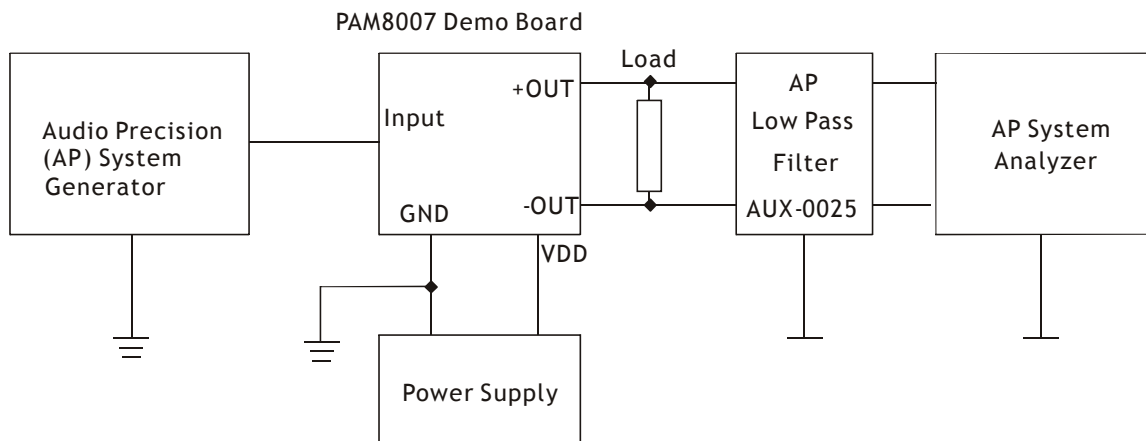

Notes

1. The Audio Precision (AP) AUX-0025 low pass filter is necessary for class-D amplifier measurement with AP analyzer.
2. Two 22 μ H inductors are used in series with load resistor to emulate the small speaker for efficiency measurement.



Application Information(continued)

Mute Operation

The MUTE pin is an input for controlling the output state of the PAM8007. A logic low on this pin disables the outputs, and a logic high on this pin enables the outputs. This pin may be used as a quick disable or enable of the outputs without a volume fade. Quiescent current is listed in the electrical characteristic table. The MUTE pin can be left floating due to the internal pull-up.

For the best power on/off pop performance, the amplifier should be placed in the Mute mode prior to turning on/off the power supply.

Shutdown operation

In order to reduce power consumption while not in use, the PAM8007 contains shutdown circuitry to turn off the amplifier's bias circuitry. The amplifier is turned off when logic low is placed on the SHDN pin. By switching the SHDN pin connected to GND, the PAM8007 supply current draw will be minimized in idle mode. The SHDN pin can be left floating due to the internal pull-up.

Line/Ear Operation

In order to control speaker/headphone switch, the PAM8007 contains detect circuitry. When line/Ear logic low, speaker active; when logic high, earphone active.

Power supply decoupling

The PAM8007 is a high performance CMOS audio amplifier that requires adequate power supply decoupling to ensure the output THD and PSRR are as low as possible. Power supply decoupling affects low frequency on the power supply leads. For higher frequency response. Optimum decoupling is achieved by using two capacitors of different types that target different types of noise frequency transients, spikes, or digital hash on the line, a good low equivalent-series-resistance (ESR) ceramic capacitor, typically 1.0µF, placed as close as possible to the device V_{DD} terminal works best. For filtering lower-frequency noise signals, a large capacitor of 10µF(ceramic) or greater placed near the audio power amplifier is recommended.

Input Capacitor (C_i)

Large input capacitors are both expensive and space hungry for portable designs. Clearly, a certain sized capacitor is needed to couple in low frequencies without severe attenuation. But in many cases the speakers used in portable systems, whether internal or external, have little

ability to reproduce signals below 100Hz to 150Hz. Thus, using a large input capacitor may not increase actual system performance. In this case, input capacitor (C_i) and input resistance (R_i) of the amplifier form a high-pass filter with the corner frequency determined equation below,

$$f_c = \frac{1}{2\pi R_i C_i}$$

In addition to system cost and size, click and pop performance is affected by the size of the input coupling capacitor, C_i. A larger input coupling capacitor requires more charge to reach its quiescent DC voltage (nominally 1/2 V_{DD}). This charge comes from the internal circuit via the feedback and is apt to create pops upon device enable. Thus, by minimizing the capacitor size based on necessary low frequency response, turn-on pops can be minimized.

Analog Reference Bypass Capacitor (C_{BYP})

The Analog Reference Bypass Capacitor (C_{BYP}) is the most critical capacitor and serves several important functions. During start-up or recovery from shutdown mode, C_{BYP} determines the rate at which the amplifier starts up. The second function is to reduce noise produced by the power supply caused by coupling into the output drive signal. This noise is from the internal analog reference to the amplifier, which appears as degraded PSRR and THD+N.

A ceramic bypass capacitor (C_{BYP}) of 0.47µF to 1.0µF is recommended for the best THD and noise performance. Increasing the bypass capacitor reduces clicking and popping noise from power on/off and entering and leaving shutdown.

Short Circuit Protection (SCP)

The PAM8007 has short circuit protection circuitry on the outputs that prevents the device from damage when output-to-output and output-to-GND short. When a short circuit is detected on the outputs, the outputs are disable immediately. If the short was removed, the device activates again.

Application Information (continued)

Over Temperature Protection

Thermal protection on the PAM8007 prevents the device from damage when the internal die temperature exceeds 150°C. There is a 15 degree tolerance on this trip point from device to device. Once the die temperature exceeds the thermal set point, the device outputs are disabled. This is not a latched fault. The thermal fault is cleared once the temperature of the die is reduced by 30°C. This large hysteresis will prevent motor boating sound well. The device begins normal operation at this point without external system interaction.

How to Reduce EMI (Electro Magnetic Interference)

A simple solution is to put an additional capacitor 1000uF at power supply terminal for power line coupling if the traces from amplifier to speakers are short (<20CM).

Most applications require a ferrite bead filter as shown at Figure 1. The ferrite filter reduces EMI around 1 MHz and higher. When selecting a ferrite bead, choose one with high impedance at high frequencies, and low impedance at low frequencies (MH2012HM221-T).

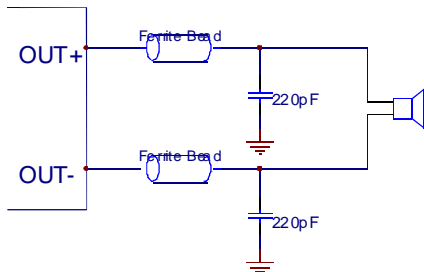

Figure 1: Ferrite Bead Filter to reduce EMI

PCB Layout Guidelines Grounding

At this stage it is paramount to notice the necessity of separate grounds. Noise currents in the output power stage need to be returned to output noise ground and nowhere else. Were these currents to circulate elsewhere, they may get into the power supply, the signal ground, etc, worse yet, they may form a loop and radiate noise. Any of these cases results in degraded amplifier performance. The logical returns for the output noise currents associated with Class D switching are the respective PGND pins for each channel. The switch state diagram illustrates that PGND is instrumental in nearly every switch state. This is the perfect point to which the output noise ground trace should return. Also note that output noise ground is channel specific. A two

channel amplifier has two separate channels and consequently must have two separate output noise ground traces. The layout of the PAM8007 offers separate PGND connections for each channel and in some cases each side of the bridge. Output noise grounds must be tied to system ground at the power in exclusively. Signal currents for the inputs, reference, etc need to be returned to quiet ground. This ground is only tied to the signal components and the GND pin, and GND then tied to system ground.

PCB Layout Example

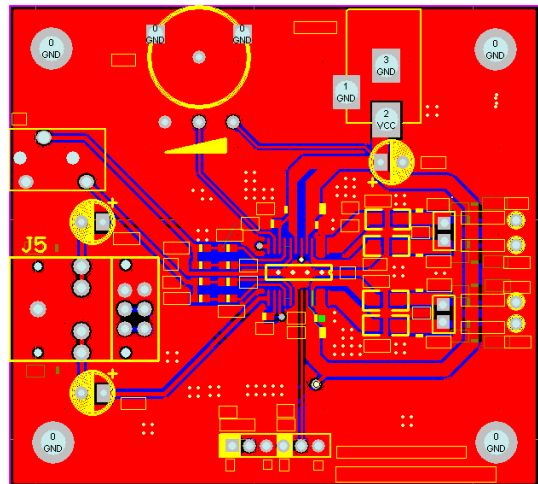

Figure 2: Top Layer

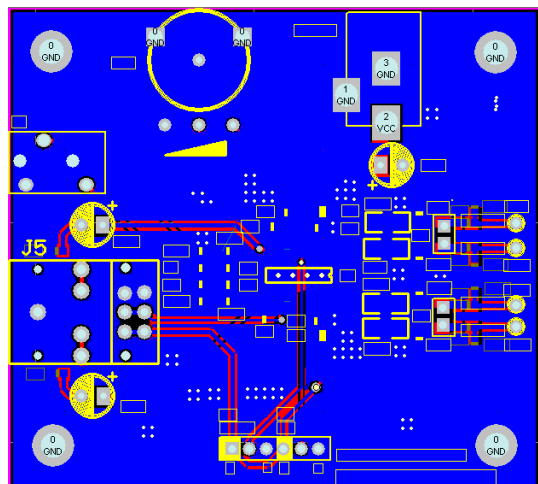

Figure 3: Bottom Layer



PAM8007

Filterless 3W Class-D Stereo Audio Amplifier
with DC Volume Control and Headphone Output

Ordering Information

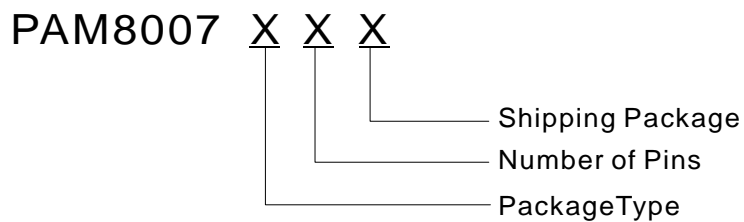

Part Number	Package Type	Standard Package
PAM8007NHR	SSOP-24	2,500 Units/Tape & Reel
PAM8007DHR	SOP-24	1,000 Units/Tape & Reel

Outline Dimension

SSOP-24

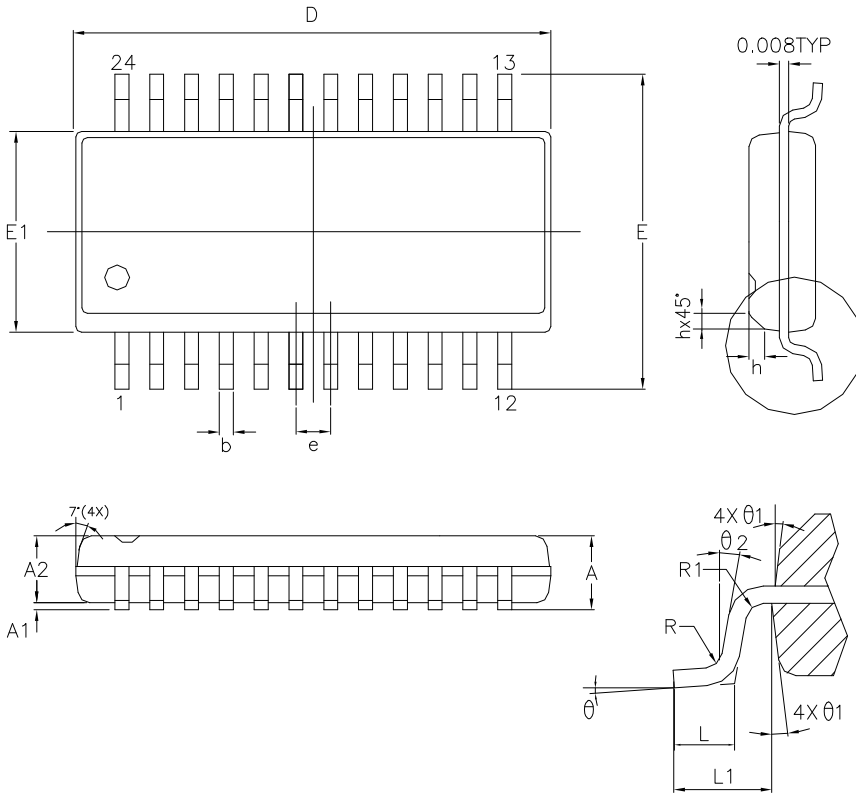

SYMBOLS	MIN.	NOM.	MAX.
A	0.053	0.061	0.069
A1	0.004	-	0.010
A2	0.049	0.057	0.065
b	0.008	0.010	0.012
D	0.335	0.341	0.347
E	0.228	0.236	0.244
E1	0.150	0.154	0.158
e	-	0.025	-
L	0.016	0.033	0.050
L1	0.041 REF		
R	0.003	-	-
R1	0.003	-	-
h	0.010	0.015	0.020
θ	0°	4°	8°
θ_1	5°	10°	15°
θ_2	0°	-	-

UNIT : INCH

Outline Dimension

SOP-24

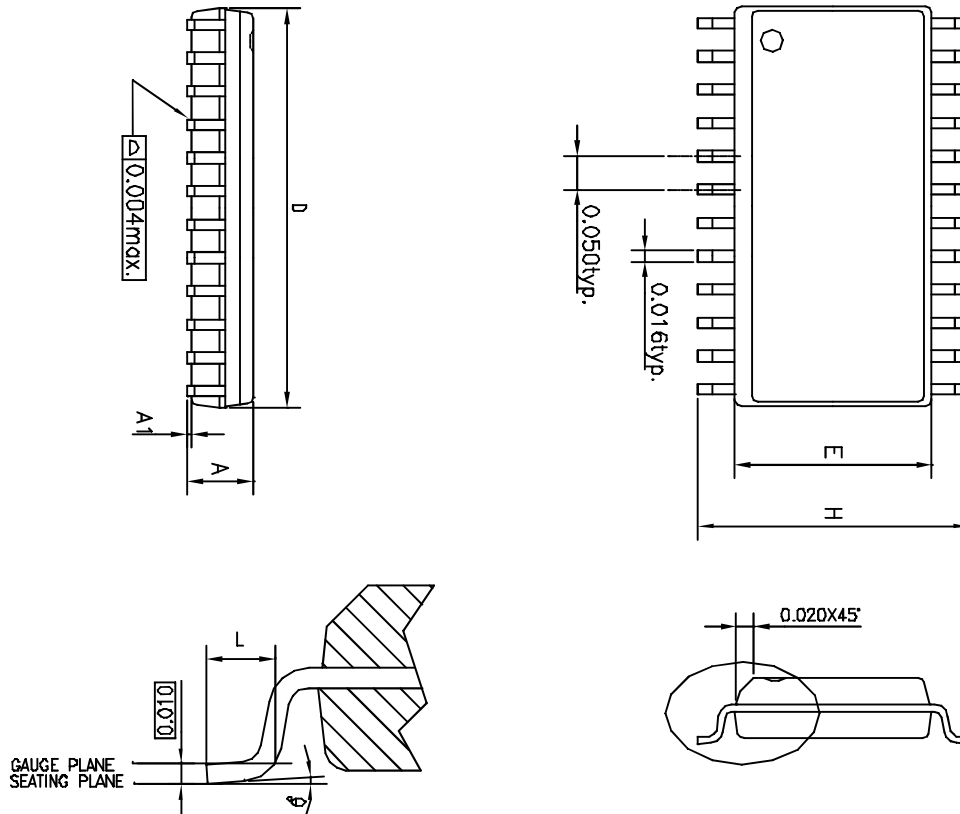

SYMBOLS	MIN.	NOM	MAX.
A	0.093	0.099	0.104
A1	0.004	—	0.012
D	0.599	0.600	0.614
E	0.291	0.295	0.299
H	0.394	0.406	0.419
L	0.016	0.035	0.050
θ°	0	—	8

UNIT : INCH

NOTES:

1. JEDEC OUTLINE : MS-013 AD
2. DIMENSIONS "D" DOES NOT INCLUDE MOLD FLASH, PROTRUSIONS OR GATE BURRS. MOLD FLASH, PROTRUSIONS AND GATE BURRS SHALL NOT EXCEED .15mm (.006in) PER SIDE.
3. DIMENSIONS "E" DOES NOT INCLUDE INTER-LEAD FLASH, OR PROTRUSIONS. INTER-LEAD FLASH AND PROTRUSIONS SHALL NOT EXCEED .25mm (.010in) PER SIDE.



Компания «ЭлектроПласт» предлагает заключение долгосрочных отношений при поставках импортных электронных компонентов на взаимовыгодных условиях!

Наши преимущества:

- Оперативные поставки широкого спектра электронных компонентов отечественного и импортного производства напрямую от производителей и с крупнейших мировых складов;
- Поставка более 17-ти миллионов наименований электронных компонентов;
- Поставка сложных, дефицитных, либо снятых с производства позиций;
- Оперативные сроки поставки под заказ (от 5 рабочих дней);
- Экспресс доставка в любую точку России;
- Техническая поддержка проекта, помощь в подборе аналогов, поставка прототипов;
- Система менеджмента качества сертифицирована по Международному стандарту ISO 9001;
- Лицензия ФСБ на осуществление работ с использованием сведений, составляющих государственную тайну;
- Поставка специализированных компонентов (Xilinx, Altera, Analog Devices, Intersil, Interpoint, Microsemi, Aeroflex, Peregrine, Syfer, Eurofarad, Texas Instrument, Miteq, Cobham, E2V, MA-COM, Hittite, Mini-Circuits, General Dynamics и др.);

Помимо этого, одним из направлений компании «ЭлектроПласт» является направление «Источники питания». Мы предлагаем Вам помощь Конструкторского отдела:

- Подбор оптимального решения, техническое обоснование при выборе компонента;
- Подбор аналогов;
- Консультации по применению компонента;
- Поставка образцов и прототипов;
- Техническая поддержка проекта;
- Защита от снятия компонента с производства.



Как с нами связаться

Телефон: 8 (812) 309 58 32 (многоканальный)

Факс: 8 (812) 320-02-42

Электронная почта: org@eplast1.ru

Адрес: 198099, г. Санкт-Петербург, ул. Калинина, дом 2, корпус 4, литера А.