

## Features

- 27 mm (1-1/16 ") diameter, single-turn wirewound
- Bushing mount
- Gangable to 8 cups
- Outstanding vibration and shock performance
- Shaft supported front and rear by precision sleeve bearings



Model 3435 is obsolete. Models 6657, 6574 and 6674 are preferred.

- High temperature, moisture resistant, thermosetting plastic housing
- Non-standard features and specifications available

## 3435 - Precision Potentiometer

### Electrical Characteristics<sup>1</sup>

Standard Resistance Range.....	50 to 20 K ohms
Total Resistance Tolerance.....	±3 %
Independent Linearity.....	±0.5 %
Effective Electrical Angle.....	350 ° ±2 °
Noise.....	100 ohms ENR maximum
Absolute Minimum Resistance.....	1 ohm or 0.1 % (whichever is greater)
Dielectric Withstanding Voltage	
Sea Level.....	1,000 VAC minimum
Power Rating	
+70 °C.....	1.5 watts
+125 °C.....	.0 watt
Insulation Resistance (500 VDC).....	1,000 megohms minimum
Resolution.....	See ordering information

### Environmental Characteristics<sup>1</sup>

Operating Temperature Range.....	+1 °C to 125 °C
Storage Temperature Range.....	-65 °C to +125 °C
Temperature Coefficient Over Storage Temperature Range <sup>2</sup> .....	±20 ppm/°C max.
Vibration (MIL-R-12934).....	15 G
Wiper Bounce.....	0.1 millisecond maximum
Total Resistance Shift.....	±5 % maximum
Voltage Ratio Shift.....	±1 % maximum
Shock (MIL-R-12934).....	50 G
Wiper Bounce.....	0.1 millisecond maximum
Total Resistance Shift.....	±5 % maximum
Voltage Ratio Shift.....	±1 % maximum
Load Life.....	1,000 hours
Total Resistance Shift.....	2.0 % maximum
Rotational Life (No Load).....	1,000,000 shaft revolutions
Total Resistance Shift.....	±5 % maximum
Moisture Resistance (MIL-STD-202, Method 106).....	
Total Resistance Shift.....	±5 % maximum
Humidity.....	MIL-R-12934 humidity cycling
Total Resistance Shift.....	±5 % maximum
IP Rating.....	IP 40

### Mechanical Characteristics<sup>1</sup>

Mechanical Angle.....	Continuous
Torque	
Starting.....	0.18 N-cm (0.25 oz.-in.) maximum
Running.....	0.18 N-cm (0.25 oz.-in.) maximum
Additional Cups.....	Add 75 % each
Mounting.....	170-200 N-cm (15-18 lb.-in.) maximum
Shaft Runout.....	0.025 mm (0.001 in.) T.I.R.
Shaft End Play.....	0.08 mm (0.003 in.) T.I.R.
Shaft Radial Play.....	0.08 mm (0.003 in.) T.I.R.
Backlash.....	0.25 ° maximum
Weight.....	Approximately 23 gm
Terminals.....	Gold-plated turret type
Soldering Condition	
Manual Soldering.....	96.5Sn/3.0Ag/0.5Cu solid wire or no-clean rosin cored wire 370 °C (700 °F) max. for 3 seconds
Wave Soldering.....	96.5Sn/3.0Ag/0.5Cu solder with no-clean flux 260 °C (500 °F) max. for 5 seconds
Wash processes.....	Not recommended
Marking.....	Manufacturer's name and part number, resistance value and tolerance, linearity tolerance, wiring diagram, date code
Ganging (Multiple Section Potentiometers).....	8 cups maximum
Hardware.....	One lockwasher (H-37-2) and one mounting nut (H-38-2) is shipped with each potentiometer.

<sup>1</sup>At room ambient: +25 °C nominal and 50 % relative humidity nominal, except as noted.

<sup>2</sup>Consult manufacturer for complete specification details.

### Product Dimensions

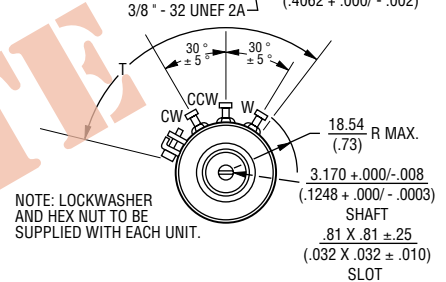
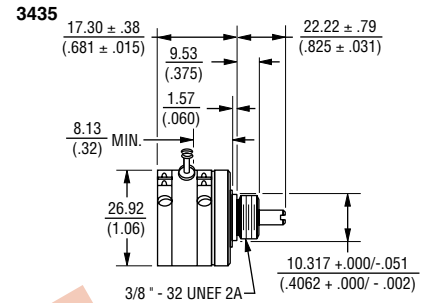

TOLERANCES: EXCEPT WHERE NOTED

DECIMALS: XX ± .51  
(.020), .XXX ± .13  
(.005)

FRACTIONS: ±1/64

DIMENSIONS: MM  
(IN.)

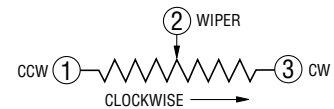

### Recommended Part Numbers

Part Number	Resistance (Ω)	Resolution (%)
3435S-1-102	1,000	.208
3435S-1-202	2,000	.178
3435S-1-502	5,000	.135
3435S-1-103	10,000	.107
3435S-1-503	50,000	.057

# 3435 - Precision Potentiometer

**BOURNS®**

## Panel Thickness Dimensions

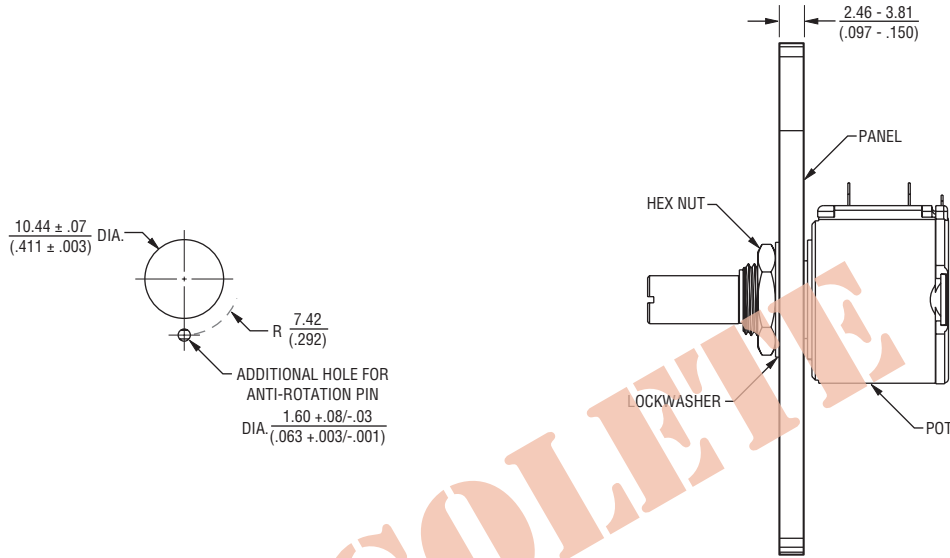

Anti-rotation pin hole is shown at six o'clock position for reference only. The actual location is determined by the customer's application. Refer to the front view of the potentiometer to see the location of the optional A/R pin.

Panel thickness and hole diameters are recommended for best fit. However, customers may adjust the dimensions to suit their specific application.

DIMENSIONS:  $\frac{\text{MM}}{\text{(INCHES)}}$

TOLERANCES:  $\pm \frac{0.127}{(.005)}$

REV. 03/12

Specifications are subject to change without notice.  
Customers should verify actual device performance in their specific applications



Компания «ЭлектроПласт» предлагает заключение долгосрочных отношений при поставках импортных электронных компонентов на взаимовыгодных условиях!

Наши преимущества:

- Оперативные поставки широкого спектра электронных компонентов отечественного и импортного производства напрямую от производителей и с крупнейших мировых складов;
- Поставка более 17-ти миллионов наименований электронных компонентов;
- Поставка сложных, дефицитных, либо снятых с производства позиций;
- Оперативные сроки поставки под заказ (от 5 рабочих дней);
- Экспресс доставка в любую точку России;
- Техническая поддержка проекта, помощь в подборе аналогов, поставка прототипов;
- Система менеджмента качества сертифицирована по Международному стандарту ISO 9001;
- Лицензия ФСБ на осуществление работ с использованием сведений, составляющих государственную тайну;
- Поставка специализированных компонентов (Xilinx, Altera, Analog Devices, Intersil, Interpoint, Microsemi, Aeroflex, Peregrine, Syfer, Eurofarad, Texas Instrument, Miteq, Cobham, E2V, MA-COM, Hittite, Mini-Circuits, General Dynamics и др.);

Помимо этого, одним из направлений компании «ЭлектроПласт» является направление «Источники питания». Мы предлагаем Вам помощь Конструкторского отдела:

- Подбор оптимального решения, техническое обоснование при выборе компонента;
- Подбор аналогов;
- Консультации по применению компонента;
- Поставка образцов и прототипов;
- Техническая поддержка проекта;
- Защита от снятия компонента с производства.



#### Как с нами связаться

**Телефон:** 8 (812) 309 58 32 (многоканальный)

**Факс:** 8 (812) 320-02-42

**Электронная почта:** [org@eplast1.ru](mailto:org@eplast1.ru)

**Адрес:** 198099, г. Санкт-Петербург, ул. Калинина, дом 2, корпус 4, литера А.