

SERIES 60C

Multi-Function Joystick

FEATURES

- Three-in-One Joystick, Optical Encoder and Pushbutton
- Compact Packaging
- Choices of Cable Length and Termination
- Customized Solutions Available

APPLICATIONS

- Avionics
- Medical Equipment
- Automotive Navigation, Information & Entertainment Equipment

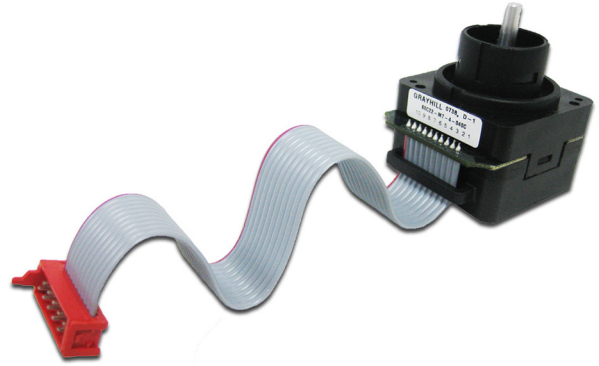

DIMENSIONS in inches (and millimeters)

Unless otherwise specified, standard tolerance are:
 Linear ± .025
 Diameter ± .010
 Angle ± 2.0°

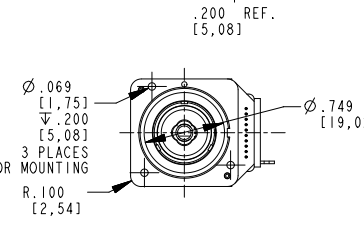
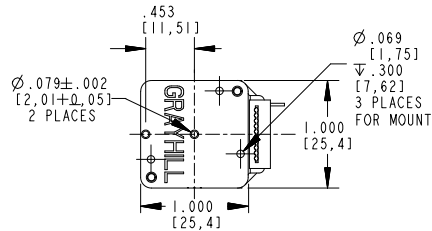
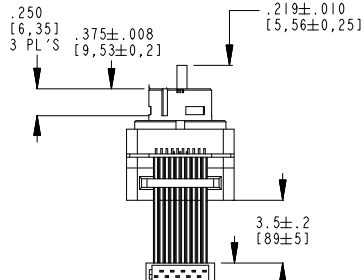
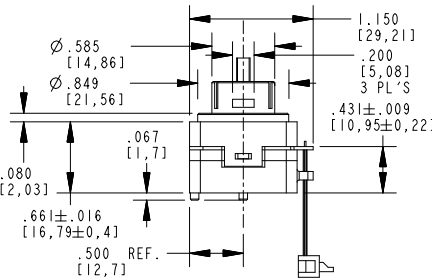

FRONT MOUNTING

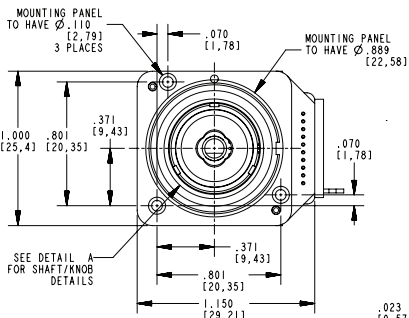

REAR MOUNTING

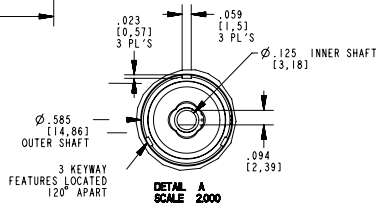
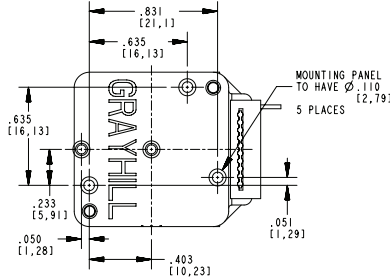

JOYSTICK OPERATION ENCODER WAVEFORM

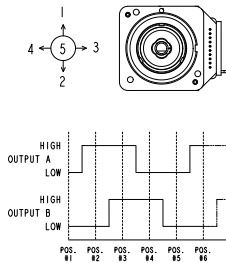

TRUTH TABLE Standard Quadrature 2-Bit Code

○ INDICATES LOGIC HIGH
 ○ INDICATES LOGIC LOW

JOYSTICK

POSITION	BIT 1	BIT 2	BIT 3	BIT 4
1	○	○	○	○
2	○	○	○	○
3	○	○	○	○
4	○	○	○	○
5	○	○	○	○

ENCODER

POSITION	OUTPUT A	OUTPUT B
#1	○	○
#2	○	○
#3	○	○
#4	○	○

SWITCH SCHEMATIC

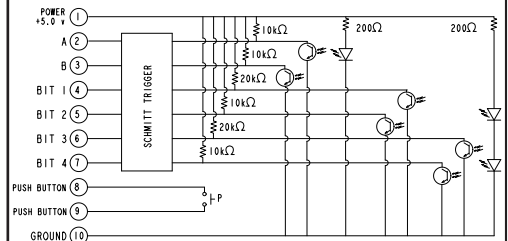

Optical and Mechanical Encoders

CONTROL KNOBS

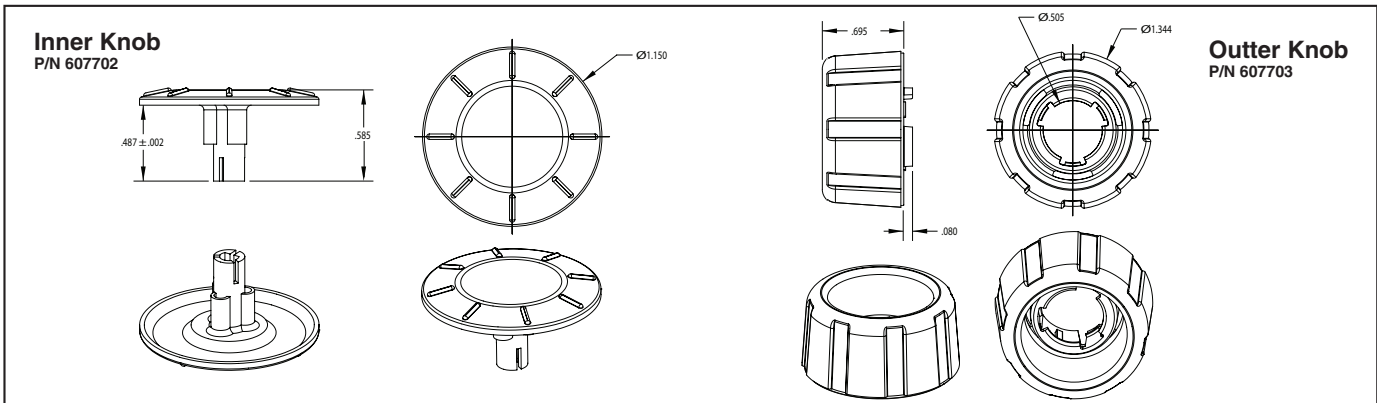

SPECIFICATIONS

Rotary

Electrical and Mechanical Ratings

Operating Voltage: 5.00 ± 0.25 Vdc**Supply Current:** 35mA TYP at 5 Vdc**Power Consumption:** 175mW TYP at 5Vdc**Output:** Direct output from inverting Schmitt trigger**Output Code:** 2-Bit quadrature, channel A leads channel B by 90° in cw rotation**Logic Output Characteristics:**

High: No less than 3.5 Vdc

Low: No greater than 1.0 Vdc

Mechanical Life: 500K rotational cycles (through all positions and a full return)**Rotational Torque:** medium torque option 3.00±2.00 in-oz, torque shall be within 50% of initial value throughout life**Mounting Torque:** 15 in-lbs. maximum**Shaft Push/Pull Out Force:** 25 lbs minimum**Terminal Strength:** 15 lbs terminal minimum

Joystick

Electrical and Mechanical Ratings

Operating Voltage: 5.00 ± 0.25 Vdc**Supply Current:** 35mA at TYP at 5 Vdc**Power Consumption:** 175mW TYP at 5Vdc**Output:** Direct output from inverting Schmitt trigger**Logic Output Characteristics:**

High: No less than 3.5 Vdc

Low: No greater than 1.0 Vdc

Mechanical Life: 500K cycles

(through all positions and a full return)

Angle of Throw: 8° max. in all directions

Pushbutton

Electrical and Mechanical Ratings

Rating: 10 mA at 5 Vdc resistive**Contact Resistance:** less than 10 ohms**Contact Bounce:** < 4ms make, 10 ms break**Mechanical Life:** 500K actuations minimum**Actuation Force:** option 7 = 485 ± 115grams**Pushbutton Travel:** 0.033 ± 0.015 inches to contact; 0.075 inches maximum

Environmental Ratings

Operating Temperature Range: -40°C to 85°C**Storage Temperature Range:** -55°C to 100°C**Relative Humidity:** 96 hours at 90-95% humidity at 40°C**Vibration:** Harmonic motion with amplitude of 15g, within a varied 10 to 2000 Hz**Mechanical Shock:**

Test 1: 100g for 6ms half-sine wave with a velocity change of 12.3 ft/s

Test 2: 100g for 6ms sawtooth wave with a velocity change of 9.7 ft/s

Thermocycle: 4 hours cycling between -40°C to 85°C

Materials and Finishes

Bushing: Thermoplastic**Shaft Outer:** Thermoplastic**Upper Housing:** Thermoplastic**Pushbutton Rocker:** Thermoplastic**Pushbutton Actuator:** Thermoplastic**Inner Shaft Slide:** Thermoplastic**Slider Plate:** Thermoplastic**Backplate:** Thermoplastic**Lightpipe, Joystick:** Thermoplastic**Lightpipe, 16 pos:** Thermoplastic**Centering Profile:** Thermoplastic**Shaft Inner:** Aluminum**Pins:** Stainless steel**Barbed Rivet:** Stainless steel**Detent Balls:** Carbon steel 100 with nickel finish**Centering Balls:** Carbon steel 100 with nickel finish**Detent Springs:** Tinned music wire**Centering Springs:** Tinned music wire**Cable ASM:** .050 round conductor flat cable, PVC coated. Conductors are stranded, top-coated wire**Solder:** 95.5% SN, 4% AG, 0.5% CU**Dome:** Stainless steel**PCB 16 Pos:** NEMA grade FR-4. Plating is gold or palladium over nickel**Infrared Emitter:** Gallium aluminum arsenide**Phototransistor:** Planar silicon**Resistor:** Carbon film**Schmitt Trigger:** RoHS Compliant TSSOP, 14 pin**Lubricating Grease:** Nyogel 774L**Label:** TT406 Thermal transfer cast film

OPTIONS

Contact Grayhill for custom terminations, rotational torque, number of positions, shaft configurations, and resolutions. Control knobs are also available.

ORDERING INFORMATION

**Series****Angle of Throw:** 22= 22.5° or 16 positions**Rotation Torque:** M= Medium torque**Pushbutton:** 7= 485 grams**Joystick:** 4= Four directions**Termination:** 0.050" center ribbon cable with; C= Connector*; S= 0.1" stripped end**Cable Length:** 025 thru 250 in 1/2 inch increments, 060= 6.0 inch cable

* AMP p/n 1-215083-0. Mating connector is p/n 1-215079-0 for thru-hole or p/n 1-188275-0 for surface mount.

Available from your local Grayhill Distributor. For prices and discounts, contact a local sales office, an authorized distributor, or Grayhill.



Компания «ЭлектроПласт» предлагает заключение долгосрочных отношений при поставках импортных электронных компонентов на взаимовыгодных условиях!

Наши преимущества:

- Оперативные поставки широкого спектра электронных компонентов отечественного и импортного производства напрямую от производителей и с крупнейших мировых складов;
- Поставка более 17-ти миллионов наименований электронных компонентов;
- Поставка сложных, дефицитных, либо снятых с производства позиций;
- Оперативные сроки поставки под заказ (от 5 рабочих дней);
- Экспресс доставка в любую точку России;
- Техническая поддержка проекта, помощь в подборе аналогов, поставка прототипов;
- Система менеджмента качества сертифицирована по Международному стандарту ISO 9001;
- Лицензия ФСБ на осуществление работ с использованием сведений, составляющих государственную тайну;
- Поставка специализированных компонентов (Xilinx, Altera, Analog Devices, Intersil, Interpoint, Microsemi, Aeroflex, Peregrine, Syfer, Eurofarad, Texas Instrument, Miteq, Cobham, E2V, MA-COM, Hittite, Mini-Circuits, General Dynamics и др.);

Помимо этого, одним из направлений компании «ЭлектроПласт» является направление «Источники питания». Мы предлагаем Вам помощь Конструкторского отдела:

- Подбор оптимального решения, техническое обоснование при выборе компонента;
- Подбор аналогов;
- Консультации по применению компонента;
- Поставка образцов и прототипов;
- Техническая поддержка проекта;
- Защита от снятия компонента с производства.



Как с нами связаться

Телефон: 8 (812) 309 58 32 (многоканальный)

Факс: 8 (812) 320-02-42

Электронная почта: org@eplast1.ru

Адрес: 198099, г. Санкт-Петербург, ул. Калинина, дом 2, корпус 4, литера А.