

Future Technology Devices International Ltd.

FT234XD

(USB to BASIC UART IC)

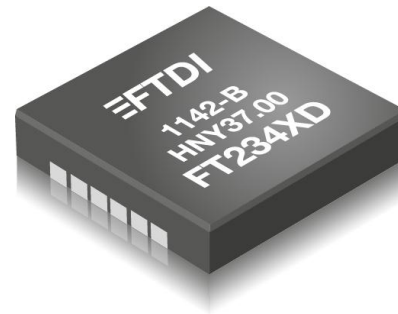

The FT234XD is a USB to serial UART interface with optimised packaging (3mm x 3mm 12 pin DFN) for smaller PCB designs and the following advanced features:

- Single chip USB to asynchronous serial data transfer interface.
- Entire USB protocol handled on the chip. No USB specific firmware programming required.
- Fully integrated 2048 byte multi-time-programmable (MTP) memory, storing device descriptors and CBUS I/O configuration.
- Fully integrated clock generation with no external crystal required plus optional clock output selection enabling a glue-less interface to external MCU or FPGA.
- Data transfer rates from 300 baud to 3 Mbaud (RS422, RS485, and RS232) at TTL levels.
- 512 byte receive buffer and 512 byte transmit buffer utilising buffer smoothing technology to allow for high data throughput.
- FTDI's royalty-free Virtual Com Port (VCP) and Direct (D2XX) drivers eliminate the requirement for USB driver development in most cases.
- Configurable CBUS I/O pin.
- Transmit and receive LED drive signals.
- UART interface support for 7 or 8 data bits, 1 or 2 stop bits and odd / even / mark / space / no parity
- Synchronous and asynchronous bit bang interface options with RD# and WR# strobes.
- USB Battery Charging Detection. Allows for USB peripheral devices to detect the presence of a higher power source to enable improved charging.
- Device supplied pre-programmed with unique USB serial number.
- USB Power Configurations; supports bus-powered, self-powered and bus-powered with power switching
- Integrated +3.3V level converter for USB I/O.
- True 3.3V CMOS drive output and TTL input; operates down to 1V8 with external pull ups. Tolerant of 5V input.
- Configurable I/O pin output drive strength; 4 mA (min) and 16 mA (max).
- Integrated power-on-reset circuit.
- Fully integrated AVCC supply filtering - no external filtering required.
- UART signal inversion option.
- + 5V Single Supply Operation.
- Internal 3.3V/1.8V LDO regulators
- Low operating and USB suspend current; 8mA (active-typ) and 70uA (suspend-typ).
- UHCI/OHCI/EHCI host controller compatible.
- USB 2.0 Full Speed compatible.
- Extended operating temperature range; -40 to 85°C.
- Available in compact Pb-free 12 pin DFN package (3mm x 3mm) RoHS compliant.

Neither the whole nor any part of the information contained in, or the product described in this manual, may be adapted or reproduced in any material or electronic form without the prior written consent of the copyright holder. This product and its documentation are supplied on an as-is basis and no warranty as to their suitability for any particular purpose is either made or implied. Future Technology Devices International Ltd will not accept any claim for damages howsoever arising as a result of use or failure of this product. Your statutory rights are not affected. This product or any variant of it is not intended for use in any medical appliance, device or system in which the failure of the product might reasonably be expected to result in personal injury. This document provides preliminary information that may be subject to change without notice. No freedom to use patents or other intellectual property rights is implied by the publication of this document. Future Technology Devices International Ltd, Unit 1, 2 Seaward Place, Centurion Business Park, Glasgow G41 1HH United Kingdom. Scotland Registered Company Number: SC136640

1 Typical Applications

- USB to RS232/RS422/RS485 Converters
- Upgrading Legacy Peripherals to USB
- Utilising USB to add system modularity
- Incorporate USB interface to enable PC transfers for development system communication
- Cellular and Cordless Phone USB data transfer cables and interfaces
- Interfacing MCU/PLD/FPGA based designs to add USB connectivity
- USB Audio and Low Bandwidth Video data transfer
- USB Smart Card Readers
- USB Instrumentation
- USB Industrial Control
- USB FLASH Card Reader and Writers
- Set Top Box PC - USB interface
- USB Wireless Modems
- USB Bar Code Readers
- USB dongle implementations for Software/ Hardware Encryption and Wireless Modules
- Detection of dedicated charging port for battery charging at higher supply currents.

1.1 Driver Support

Royalty free VIRTUAL COM PORT (VCP) DRIVERS for...

- Windows 8 32,64-bit
- Windows 7 32,64-bit
- Windows Vista and Vista 64-bit
- Windows XP and XP 64-bit
- Server 2003, XP and Server 2008
- Windows XP Embedded
- Windows CE 4.2, 5.0 and 6.0
- Mac OS-X
- Linux 3.2 and greater
- Android

Royalty free D2XX *Direct* Drivers (USB Drivers + DLL S/W Interface)

- Windows 8 32,64-bit
- Windows 7 32,64-bit
- Windows Vista and Vista 64-bit
- Windows XP and XP 64-bit
- Server 2003, XP and Server 2008
- Windows XP Embedded
- Windows CE 4.2, 5.0 and 6.0
- Mac OS-X
- Linux 2.6 and greater
- Android

The drivers listed above are all available to download for free from FTDI website (www.ftdichip.com). Various 3rd party drivers are also available for other operating systems - see FTDI website (www.ftdichip.com) for details.

For driver installation, please refer to <http://www.ftdichip.com/Documents/InstallGuides.htm>

1.2 Part Numbers

Part Number	Package
FT234XD-x	12 Pin DFN

Note: Packing codes for x is:

- R: Taped and Reel - 5,000pcs per reel.
- T: Tray packing - 490pcs per tray.

1.3 USB Compliant

The FT234XD is fully compliant with the USB 2.0 specification and has been given the USB-IF Test-ID (TID) 40001465 (Rev D).



2 FT234XD Block Diagram

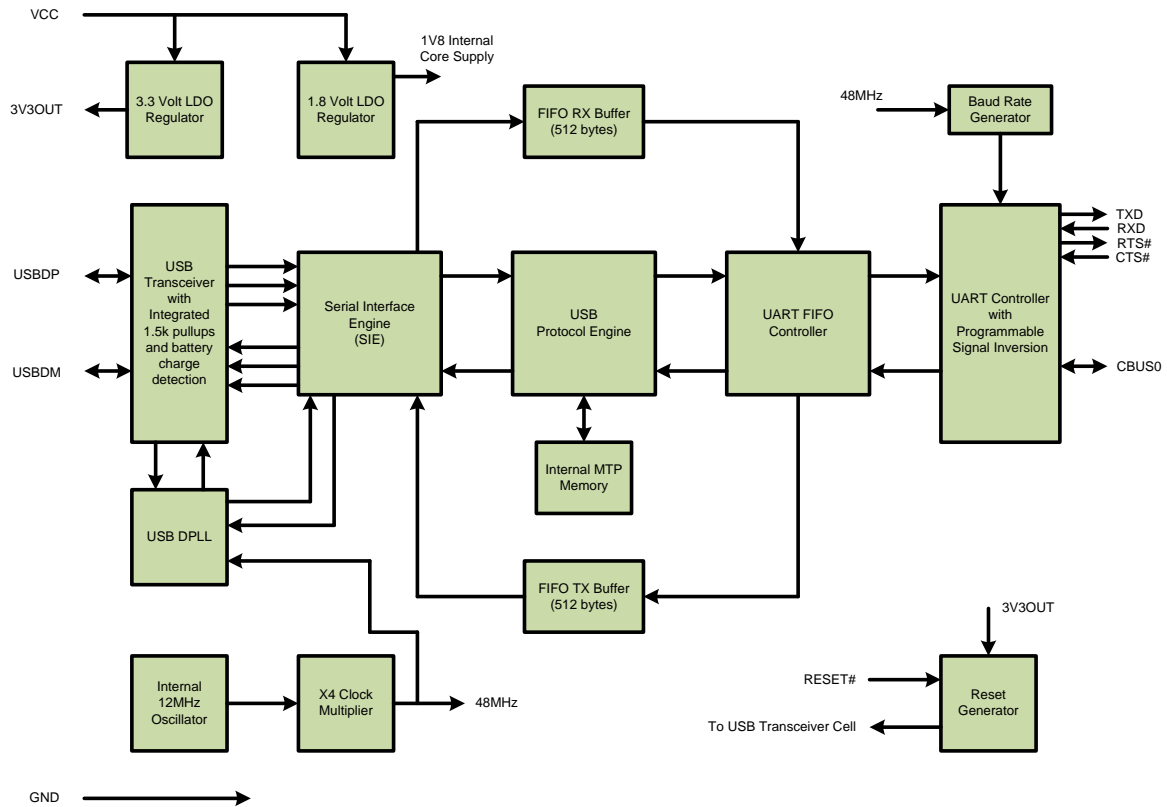

Figure 2.1 FT234XD Block Diagram

For a description of each function please refer to Section 4.

Table of Contents

1	Typical Applications	2
1.1	Driver Support	2
1.2	Part Numbers.....	2
1.3	USB Compliant	3
2	FT234XD Block Diagram	4
3	Device Pin Out and Signal Description	7
3.1	12-Pin DFN Package.....	7
3.1.1	DFN Package PinOut Description	7
3.2	CBUS Signal Options	9
4	Function Description	11
4.1	Key Features.....	11
4.2	Functional Block Descriptions	11
5	Devices Characteristics and Ratings	14
5.1	Absolute Maximum Ratings.....	14
5.2	DC Characteristics.....	15
5.3	MTP Memory Reliability Characteristics	19
5.4	Internal Clock Characteristics.....	19
6	USB Power Configurations	20
6.1	USB Bus Powered Configuration	20
6.2	Self Powered Configuration	21
6.3	USB Bus Powered with Power Switching Configuration	22
7	Application Examples	23
7.1	USB to RS232 Converter	23
7.2	USB to RS485 Coverter	24
	USB to RS422 Converter	25
7.3	25
7.4	USB Battery Charging Detection	26
7.5	LED Interface.....	27
8	Internal MTP Memory Configuration	28
8.1	Default Values	28
8.2	Methods of Programming the MTP Memory.....	29
8.2.1	Programming the MTP memory over USB.....	29
8.3	Memory Map	30
9	Package Parameters	31
9.1	DFN-12 Package Mechanical Dimensions	31

9.2	DFN-12 Package Markings	32
9.3	Solder Reflow Profile	33
10	Contact Information	34
	Appendix A – References	35
	Appendix B - List of Figures and Tables	36
	Appendix C - Revision History.....	37

3 Device Pin Out and Signal Description

3.1 12-Pin DFN Package

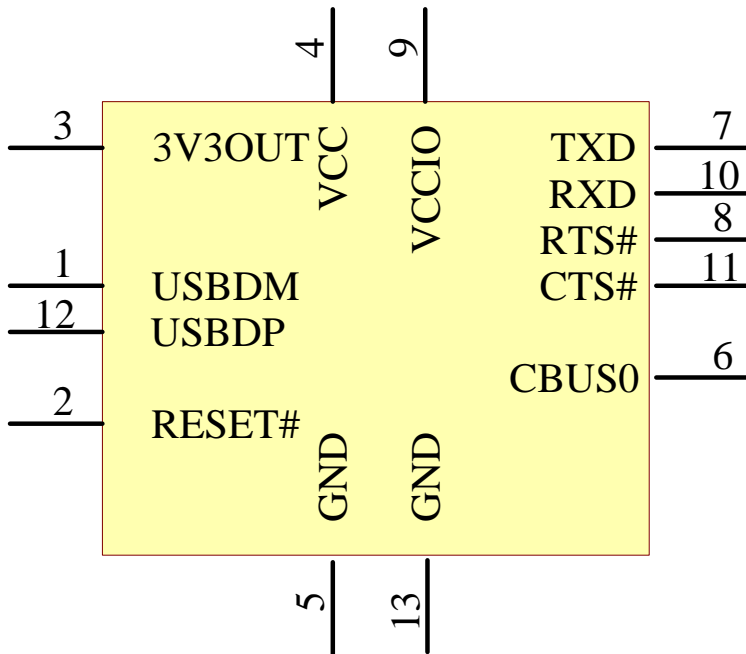

Figure 3.1 DFN Schematic Symbol

3.1.1 DFN Package PinOut Description

Note : # denotes an active low signal.

Pin No.	Name	Type	Description
4	** VCC	POWER Input	5 V (or 3.3V) supply to IC
9	VCCIO	POWER Input	1.8V – 3.3V supply for the IO cells
3	** 3.3VOUT	POWER Output	3.3V output at 50mA. May be used to power VCCIO. When VCC is 3.3V; pin 3 is an input pin and should be connected to pin 4.
5, 13	GND	POWER Input	0V Ground input.

Table 3.1 Power and Ground

*Pin 13 is the centre pad under the IC. Connect to GND.

** If VCC is 3.3V then 3.3VOUT must also be driven with 3.3V input

Pin No.	Name	Type	Description
1	USBDM	INPUT/OUTPUT	USB Data Signal Minus.
12	USBDP	INPUT/OUTPUT	USB Data Signal Plus.
2	RESET#	INPUT	Reset input (active low).

Table 3.2 Common Function pins

Pin No.	Name	Type	Description
7	TXD	Output	Transmit Asynchronous Data Output.
10	RXD	Input	Receiving Asynchronous Data Input.
8	RTS#	Output	Request to Send Control Output / Handshake Signal.
11	CTS#	Input	Clear To Send Control Input / Handshake Signal.
6	CBUS0	I/O	Configurable CBUS I/O Pin. Function of this pin is configured in the device MTP memory. The default configuration is TXDEN. See CBUS Signal Options, Table 3.4.

Table 3.3 UART Interface and CBUS Group (see note 1)
Notes:

1. When used in Input Mode, the input pins are pulled to VCCIO via internal 75k Ω (approx) resistors. These pins can be programmed to gently pull low during USB suspend (PWREN# = "1") by setting an option in the MTP memory.

3.2 CBUS Signal Options

The following options can be configured on the CBUS0 I/O pin. These options can be configured in the internal MTP memory using the software utility FT_PROG which can be downloaded from the FTDI Utilities (www.ftdichip.com). The default configuration is described in Section 8.

CBUS Signal Option	CBUS Pin	Description
TRI-STATE	CBUS0	IO Pad is tri-stated
DRIVE 1	CBUS0	Output a constant 1
DRIVE 0	CBUS0	Output a constant 0
TXDEN	CBUS0	Enable transmit data for RS485
PWREN#	CBUS0	Output is low after the device has been configured by USB, then high during USB suspend mode. This output can be used to control power to external logic P-Channel logic level MOSFET switch. Enable the interface pull-down option when using the PWREN# in this way.
TXLED#	CBUS0	Transmit data LED drive – pulses low when transmitting data via USB. See Section 7.5 for more details.
RXLED#	CBUS0	Receive data LED drive – pulses low when receiving data via USB. See Section 7.5 for more details.
TX&RXLED#	CBUS0	LED drive – pulses low when transmitting or receiving data via USB. See Section 7.5 for more details.
SLEEP#	CBUS0	Goes low during USB suspend mode. Typically used to power down an external TTL to RS232 level converter IC in USB to RS232 converter designs.
CLK24MHz	CBUS0	24 MHz Clock output.*
CLK12MHz	CBUS0	12 MHz Clock output.*
CLK6MHz	CBUS0	6 MHz Clock output.*
GPIO	CBUS0	CBUS bit bang mode option. Allows the CBUS pin to be used as general purpose I/O. Configured in the internal MTP memory. A separate application note, AN232R-01, available from FTDI website (www.ftdichip.com) describes in more detail how to use CBUS bit bang mode.
BCD Charger	CBUS0	Battery Charging Detection, indicates when the device is connected to a dedicated battery charger host. Active high output.
BCD Charger#	CBUS0	Inverse of BCD Charger
BitBang_WR#	CBUS0	Synchronous and asynchronous bit bang mode WR# strobe output.
BitBang_RD#	CBUS0	Synchronous and asynchronous bit bang mode RD# strobe output.
VBUS Sense	CBUS0	Input to detect when VBUS is present.
Time Stamp	CBUS0	Toggle signal which changes state each time a USB

CBUS Signal Option	CBUS Pin	Description
		SOF is received
Keep_Awake#	CBUS0	Prevents the device from entering suspend state when unplugged.

Table 3.4 CBUS Configuration Control

*When in USB suspend mode the outputs clocks are also suspended.

4 Function Description

The FT234XD is a compact USB to a basic serial UART interface device which simplifies USB implementations in a small optimised package. The device reduces external component count by fully integrating an MTP memory, and an integrated clock circuit which requires no external crystal. It has been designed to operate efficiently with USB host controllers by using as little bandwidth as possible when compared to the total USB bandwidth available.

4.1 Key Features

Functional Integration. Fully integrated MTP memory, clock generation, AVCC filtering, Power-On-Reset (POR) and LDO regulators.

Configurable CBUS I/O Pin Options. The fully integrated MTP memory allows configuration of the Control Bus (CBUS) functionality and drive strength selection. There is one CBUS I/O pin CBUS0. The configurable options of CBUS0 are detailed in section 3.2

The CBUS line can be configured with any one of these output options by setting bits in the internal MTP memory. The device is shipped with the most commonly used pin definitions pre-programmed - see Section 8 for details.

Asynchronous Bit Bang Mode with RD# and WR# Strokes. The FT234XD supports FTDI's previous chip generation bit-bang mode. In bit-bang mode, the four UART lines can be switched from the regular interface mode to a 4-bit general purpose I/O port. Data packets can be sent to the device and they will be sequentially sent to the interface at a rate controlled by an internal timer (equivalent to the baud rate pre-scalar). Either the internal RD# or the internal WR# strobe signal can be mapped to the CBUS0 pin (only one CBUS pin available) which can be used to allow external logic to be clocked by access to the bit-bang I/O bus. This option will be described more fully in a separate application note available from FTDI website (www.ftdichip.com).

Synchronous Bit Bang Mode. The FT234XD supports synchronous bit bang mode. This mode differs from asynchronous bit bang mode in that the interface pins are only read when the device is written to. This makes it easier for the controlling program to measure the response to an output stimulus as the data returned is synchronous to the output data. An application note, AN232R-01, available from FTDI website (www.ftdichip.com) describes this feature.

Source Power and Power Consumption. The FT234XD is capable of operating at a voltage supply between +3.3V and +5.25V with a nominal operational mode current of 8mA and a nominal USB suspend mode current of 125µA. This allows greater margin for peripheral designs to meet the USB suspend mode current limit of 2.5mA. An integrated level converter within the UART interface allows the FT234XD to interface to UART logic running at +1.8V to +3.3V (5V tolerant).

4.2 Functional Block Descriptions

The following paragraphs detail each function within the FT234XD. Please refer to the block diagram shown in Figure 2.1

Internal MTP Memory. The internal MTP memory in the FT234XD is used to store USB Vendor ID (VID), Product ID (PID), device serial number, product description string and various other USB configuration descriptors. The internal MTP memory is also used to configure the CBUS pin functions. The FT234XD is supplied with the internal MTP memory pre-programmed as described in Section 8. A user area of the internal MTP memory is available to system designers to allow storing additional data from the user application over USB. The internal MTP memory descriptors can be programmed in circuit, over USB without any additional voltage requirement. The descriptors can be programmed using the FTDI utility software called FT_PROG, which can be downloaded from FTDI Utilities on the FTDI website (www.ftdichip.com).

+3.3V LDO Regulator. The +3.3V LDO regulator generates the +3.3V reference voltage for driving the USB transceiver cell output buffers. It requires an external decoupling capacitor to be attached to the 3V3OUT regulator output pin. It also provides +3.3V power to the 1.5kΩ internal pull up resistor on USBDP. The main function of the LDO is to power the USB Transceiver and the Reset Generator Cells rather than to power external logic. However, it can be used to supply external circuitry requiring a +3.3V nominal supply with a maximum current of 50mA.

+1.8V LDO Regulator. The +1.8V LDO regulator generates the +1.8V reference voltage for internal use driving the IC core functions of the serial interface engine and USB protocol engine.

USB Transceiver. The USB Transceiver Cell provides the USB 1.1 / USB 2.0 full-speed physical interface to the USB cable. The output drivers provide +3.3V level slew rate control signalling, whilst a differential input receiver and two single ended input receivers provide USB data in, Single-Ended-0 (SE0) and USB reset detection conditions respectively. This function also incorporates a 1.5kΩ pull up resistor on USB DP. The block also detects when connected to a USB power supply which will not enumerate the device but still supply power and may be used for battery charging.

USB DPLL. The USB DPLL cell locks on to the incoming NRZI USB data and generates recovered clock and data signals for the Serial Interface Engine (SIE) block.

Internal 12MHz Oscillator - The Internal 12MHz Oscillator cell generates a 12MHz reference clock. This provides an input to the x4 Clock Multiplier function. The 12MHz Oscillator is also used as the reference clock for the SIE, USB Protocol Engine and UART FIFO controller blocks.

Clock Multiplier / Divider. The Clock Multiplier / Divider takes the 12MHz input from the Internal Oscillator function and generates the 48MHz, 24MHz, 12MHz and 6MHz reference clock signals. The 48MHz clock reference is used by the USB DPLL and the Baud Rate Generator blocks.

Serial Interface Engine (SIE). The Serial Interface Engine (SIE) block performs the parallel to serial and serial to parallel conversion of the USB data. In accordance with the USB 2.0 specification, it performs bit stuffing/un-stuffing and CRC5/CRC16 generation. It also verifies the CRC on the USB data stream.

USB Protocol Engine. The USB Protocol Engine manages the data stream from the device USB control endpoint. It handles the low level USB protocol requests generated by the USB host controller and the commands for controlling the functional parameters of the UART in accordance with the USB 2.0 specification chapter 9.

FIFO RX Buffer (512 bytes). Data sent from the USB host controller to the UART via the USB data OUT endpoint is stored in the FIFO RX (receive) buffer. Data is removed from the buffer to the UART transmit register under control of the UART FIFO controller. (Rx relative to the USB interface).

FIFO TX Buffer (512 bytes). Data from the UART receive register is stored in the TX buffer. The USB host controller removes data from the FIFO TX Buffer by sending a USB request for data from the device data IN endpoint. (Tx relative to the USB interface).

UART FIFO Controller. The UART FIFO controller handles the transfer of data between the FIFO RX and TX buffers and the UART transmit and receive registers.

UART Controller with Programmable Signal Inversion and High Drive. Together with the UART FIFO Controller the UART Controller handles the transfer of data between the FIFO RX and FIFO TX buffers and the UART transmit and receive registers. It performs asynchronous 7 or 8 bit parallel to serial and serial to parallel conversion of the data on the RS232 (or RS422 or RS485) interface.

Control signals supported by UART mode include RTS, CTS. The UART Controller also provides a transmitter enable control signal pin option (TXDEN) to assist with interfacing to RS485 transceivers. RTS/CTS and XON / XOFF handshaking options are also supported. Handshaking is handled in hardware to ensure fast response times. The UART interface also supports the RS232 BREAK setting and detection conditions.

Additionally, the UART signals can each be individually inverted and have a configurable high drive strength capability (using FT_PROG). Both these features are configurable in the MTP memory.

Baud Rate Generator - The Baud Rate Generator provides a 16x clock input to the UART Controller from the 48MHz reference clock. It consists of a 14 bit pre-scalar and 3 register bits which provide fine tuning of the baud rate (used to divide by a number plus a fraction or "sub-integer"). This determines the baud rate of the UART, which is programmable from 183 baud to 3 Mbaud.

The FT234XD supports all standard baud rates and non-standard baud rates from 183 Baud up to 3 Mbaud. Achievable non-standard baud rates are calculated as follows -

$$\text{Baud Rate} = 3000000 / (n + x)$$

where 'n' can be any integer between 2 and 16,384 ($= 2^{14}$) and 'x' can be a sub-integer of the value 0, 0.125, 0.25, 0.375, 0.5, 0.625, 0.75, or 0.875. When $n = 1$, $x = 0$, i.e. baud rate divisors with values between 1 and 2 are not possible.

This gives achievable baud rates in the range 183.1 baud to 3,000,000 baud. When a non-standard baud rate is required simply pass the required baud rate value to the driver as normal, and the FTDI driver will calculate the required divisor, and set the baud rate. See FTDI application note AN232B-05 on the FTDI website (www.ftdichip.com) for more details.

RESET Generator - The integrated Reset Generator Cell provides a reliable power-on reset to the device internal circuitry at power up. The RESET# input pin allows an external device to reset the FT234XD.

RESET# can be tied to VCC or left unconnected if not being used.

5 Devices Characteristics and Ratings

5.1 Absolute Maximum Ratings

The absolute maximum ratings for the FT234XD devices are as follows. These are in accordance with the Absolute Maximum Rating System (IEC 60134). Exceeding these may cause permanent damage to the device.

Parameter	Value	Unit	Conditions
Storage Temperature	-65°C to 150°C	Degrees C	
Floor Life (Out of Bag) At Factory Ambient (30°C / 60% Relative Humidity)	168 Hours (IPC/JEDEC J-STD-033A MSL Level 3 Compliant)*	Hours	
Ambient Operating Temperature (Power Applied)	-40°C to 85°C	Degrees C	
MTTF FT234XD	TBD	Hours	
VCC Supply Voltage	-0.3 to +5.5	V	
VCCIO IO Voltage	-0.3 to +4.0	V	
DC Input Voltage – USBDP and USBDM	-0.5 to +3.63	V	
DC Input Voltage – High Impedance Bi-directionals (powered from VCCIO)	-0.3 to +5.8	V	
DC Output Current – Outputs	22	mA	

Table 5.1 Absolute Maximum Ratings

* If devices are stored out of the packaging beyond this time limit the devices should be baked before use. The devices should be ramped up to a temperature of +125°C and baked for up to 17 hours.

5.2 DC Characteristics

DC Characteristics (Ambient Temperature = -40°C to +85°C)

Parameter	Description	Minimum	Typical	Maximum	Units	Conditions
VCC	VCC Operating Supply Voltage	2.97	5	5.5	V	Normal Operation
VCC2	VCCIO Operating Supply Voltage	1.62	---	3.63	V	
Icc1	Operating Supply Current	6.5	8	8.3	mA	Normal Operation
Icc2	Operating Supply Current		125		μA	USB Suspend
3V3	3.3v regulator output	2.97	3.3	3.63	V	VCC must be greater than 3V3 otherwise 3V3OUT is an input which must be driven with 3.3V

Table 5.2 Operating Voltage and Current

Parameter	Description	Minimum	Typical	Maximum	Units	Conditions
Voh	Output Voltage High	2.97	VCCIO	VCCIO	V	Ioh = +/-2mA I/O Drive strength* = 4mA
		2.97	VCCIO	VCCIO	V	I/O Drive strength* = 8mA
		2.97	VCCIO	VCCIO	V	I/O Drive strength* = 12mA
		2.97	VCCIO	VCCIO	V	I/O Drive strength* = 16mA
Vol	Output Voltage Low		0	0.4	V	Iol = +/-2mA I/O Drive strength* = 4mA
			0	0.4	V	I/O Drive strength* = 8mA
			0	0.4	V	I/O Drive strength* = 12mA
			0	0.4	V	I/O Drive strength* = 16mA
Vil	Input low Switching Threshold			0.8	V	LVTTL
Vih	Input High Switching Threshold	2.0			V	LVTTL
Vt	Switching Threshold		1.49		V	LVTTL
Vt-	Schmitt trigger negative going threshold voltage		1.15		V	
Vt+	Schmitt trigger positive going threshold voltage		1.64		V	
Rpu	Input pull-up resistance	40	75	190	KΩ	Vin = 0
Rpd	Input pull-down resistance	40	75	190	KΩ	Vin = VCCIO
Iin	Input Leakage Current	-10	+/-1	10	μA	Vin = 0
Ioz	Tri-state output leakage current	-10	+/-1	10	μA	Vin = 5.5V or 0

Table 5.3 I/O Pin Characteristics VCCIO = +3.3V (except USB PHY pins)

* The I/O drive strength and slow slew-rate are configurable in the MTP memory.

Parameter	Description	Minimum	Typical	Maximum	Units	Conditions
Voh	Output Voltage High	2.25	VCCIO	VCCIO	V	Ioh = +/-2mA I/O Drive strength* = 4mA
		2.25	VCCIO	VCCIO	V	I/O Drive strength* = 8mA
		2.25	VCCIO	VCCIO	V	I/O Drive strength* = 12mA
		2.25	VCCIO	VCCIO	V	I/O Drive strength* = 16mA
Vol	Output Voltage Low		0	0.4	V	Iol = +/-2mA I/O Drive strength* = 4mA
			0	0.4	V	I/O Drive strength* = 8mA
			0	0.4	V	I/O Drive strength* = 12mA
			0	0.4	V	I/O Drive strength* = 16mA
Vil	Input low Switching Threshold			0.8	V	LVTTL
Vih	Input High Switching Threshold	0.8			V	LVTTL
Vt	Switching Threshold		1.1		V	LVTTL
Vt-	Schmitt trigger negative going threshold voltage		0.8		V	
Vt+	Schmitt trigger positive going threshold voltage		1.2		V	
Rpu	Input pull-up resistance	40	75	190	KΩ	Vin = 0
Rpd	Input pull-down resistance	40	75	190	KΩ	Vin = VCCIO
Iin	Input Leakage Current	-10	+/-1	10	μA	Vin = 0
Ioz	Tri-state output leakage current	-10	+/-1	10	μA	Vin = 5.5V or 0

Table 5.4 I/O Pin Characteristics VCCIO = +2.5V (except USB PHY pins)

* The I/O drive strength and slow slew-rate are configurable in the MTP memory.

Parameter	Description	Minimum	Typical	Maximum	Units	Conditions
Voh	Output Voltage High	1.62	VCCIO	VCCIO	V	Ioh = +/-2mA I/O Drive strength* = 4mA
		1.62	VCCIO	VCCIO	V	I/O Drive strength* = 8mA
		1.62	VCCIO	VCCIO	V	I/O Drive strength* = 12mA
		1.62	VCCIO	VCCIO	V	I/O Drive strength* = 16mA
Vol	Output Voltage Low		0	0.4	V	Iol = +/-2mA I/O Drive strength* = 4mA
			0	0.4	V	I/O Drive strength* = 8mA
			0	0.4	V	I/O Drive strength* = 12mA
			0	0.4	V	I/O Drive strength* = 16mA
Vil	Input low Switching Threshold			0.77	V	LVTTL
Vih	Input High Switching Threshold	1.6			V	LVTTL
Vt	Switching Threshold		0.77		V	LVTTL
Vt-	Schmitt trigger negative going threshold voltage		0.557		V	
Vt+	Schmitt trigger positive going threshold voltage		0.893		V	
Rpu	Input pull-up resistance	40	75	190	KΩ	Vin = 0
Rpd	Input pull-down resistance	40	75	190	KΩ	Vin = VCCIO
Iin	Input Leakage Current	-10	+/-1	10	μA	Vin = 0
Ioz	Tri-state output leakage current	-10	+/-1	10	μA	Vin = 5.5V or 0

Table 5.5 I/O Pin Characteristics VCCIO = +1.8V (except USB PHY pins)

* The I/O drive strength and slow slew-rate are configurable in the MTP memory.

Parameter	Description	Minimum	Typical	Maximum	Units	Conditions
Voh	Output Voltage High	VCC-0.2			V	
Vol	Output Voltage Low			0.2	V	
Vil	Input low Switching Threshold		-	0.8	V	
Vih	Input High Switching Threshold	2.0	-		V	

Table 5.6 USB I/O Pin (USBDP, USBDM) Characteristics

5.3 MTP Memory Reliability Characteristics

The internal 2048 Byte MTP memory has the following reliability characteristics:

Parameter	Value	Unit
Data Retention	10	Years
Write Cycle	2,000	Cycles
Read Cycle	Unlimited	Cycles

Table 5.7 MTP Memory Characteristics

5.4 Internal Clock Characteristics

The internal Clock Oscillator has the following characteristics:

Parameter	Value			Unit
	Minimum	Typical	Maximum	
Frequency of Operation (see Note 1)	11.98	12.00	12.02	MHz
Clock Period	83.19	83.33	83.47	ns
Duty Cycle	45	50	55	%

Table 5.8 Internal Clock Characteristics

Note 1: Equivalent to +/-1667ppm

6 USB Power Configurations

The following sections illustrate possible USB power configurations for the FT234XD. The illustrations have omitted pin numbers for ease of understanding since the pins differ between the FT234XDS and FT234XDQ package options.

All USB power configurations illustrated apply to both package options for the FT234XD device. Please refer to Section 9 for the package option pin-out and signal descriptions.

6.1 USB Bus Powered Configuration

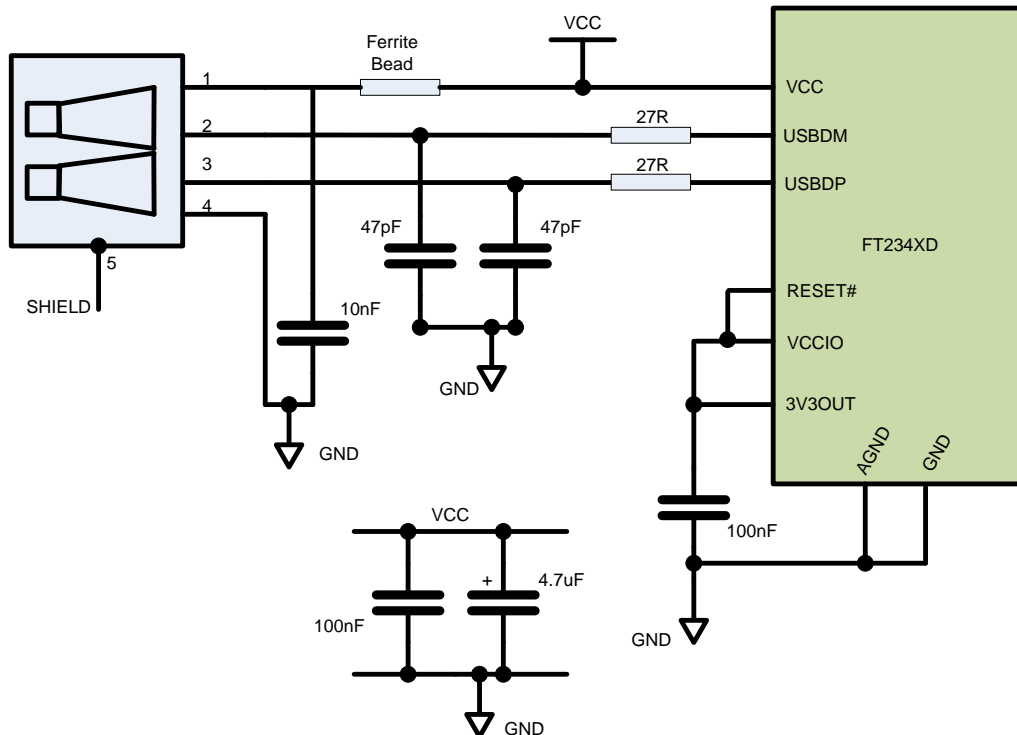

Figure 6.1 Bus Powered Configuration

Figure 6.1 illustrates the FT234XD in a typical USB bus powered design configuration. A USB bus powered device gets its power from the USB bus. Basic rules for USB bus power devices are as follows –

- i) On plug-in to USB, the device should draw no more current than 100mA.
- ii) In USB Suspend mode the device should draw no more than 2.5mA.
- iii) A bus powered high power USB device (one that draws more than 100mA) should use the CBUS pin configured as PWREN# and use it to keep the current below 100mA on plug-in and 2.5mA on USB suspend.
- iv) A device that consumes more than 100mA cannot be plugged into a USB bus powered hub.
- v) No device can draw more than 500mA from the USB bus.

The power descriptors in the internal MTP memory of the FT234XD should be programmed to match the current drawn by the device.

A ferrite bead is connected in series with the USB power supply to reduce EMI noise from the FT234XD and associated circuitry being radiated down the USB cable to the USB host. The value of the Ferrite Bead depends on the total current drawn by the application. A suitable range of Ferrite Beads is available from Laird Technologies (<http://www.lairdtech.com>) for example Laird Technologies Part # MI0805K601R-10.

6.2 Self Powered Configuration

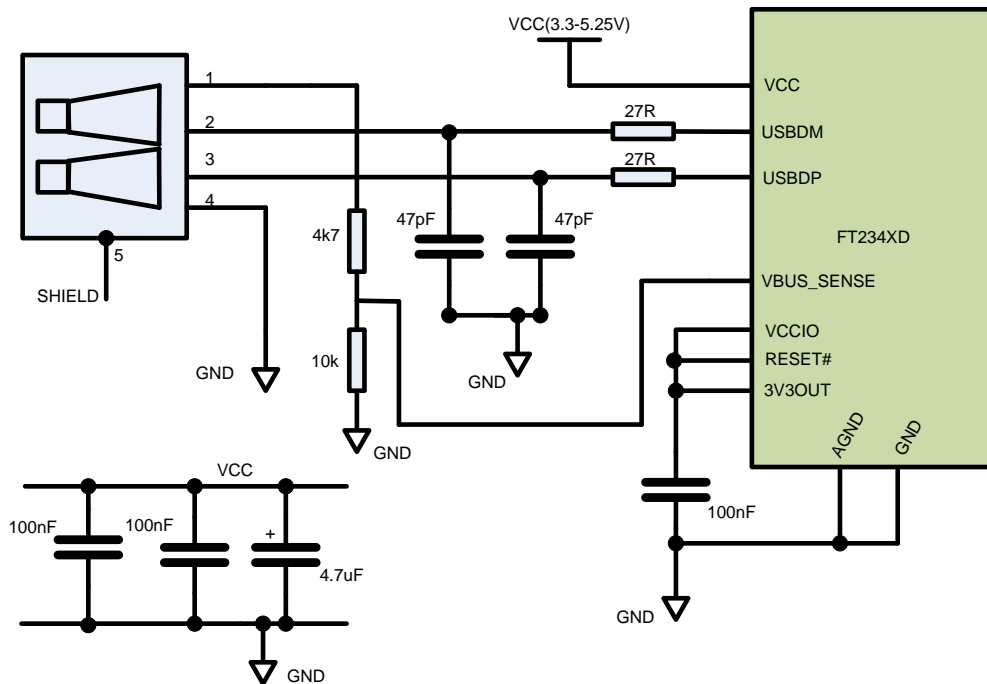

Figure 6.2 Self Powered Configuration

Figure 6.2 illustrates the FT234XD in a typical USB self powered configuration. A USB self powered device gets its power from its own power supply, VCC, and does not draw current from the USB bus. The basic rules for USB self powered devices are as follows –

- i) A self powered device should not force current down the USB bus when the USB host or hub controller is powered down.
- ii) A self powered device can use as much current as it needs during normal operation and USB suspend as it has its own power supply.
- iii) A self powered device can be used with any USB host, a bus powered USB hub or a self powered USB hub.

The power descriptor in the internal MTP memory of the FT234XD should be programmed to a value of zero (self powered).

In order to comply with the first requirement above, the USB bus power (pin 1) is used to control the VBUS_Sense pin of the FT234XD device. When the USB host or hub is powered up an internal 1.5kΩ resistor on USBDP is pulled up to +3.3V, thus identifying the device as a full speed device to the USB host or hub. When the USB host or hub is powered off, VBUS_Sense pin will be low and the FT234XD is held in a suspend state. In this state the internal 1.5kΩ resistor is not pulled up to any power supply (hub or host is powered down), so no current flows down USBDP via the 1.5kΩ pull-up resistor. Failure to do this may cause some USB host or hub controllers to power up erratically.

Figure 6.2 illustrates a self powered design which has a +3.3V to +5.25V supply.

Note:

1. When the FT234XD is in reset, the UART interface I/O pins are tri-stated. Input pins have internal 75kΩ pull-up resistors to VCCIO, so they will gently pull high unless driven by some external logic.

6.3 USB Bus Powered with Power Switching Configuration

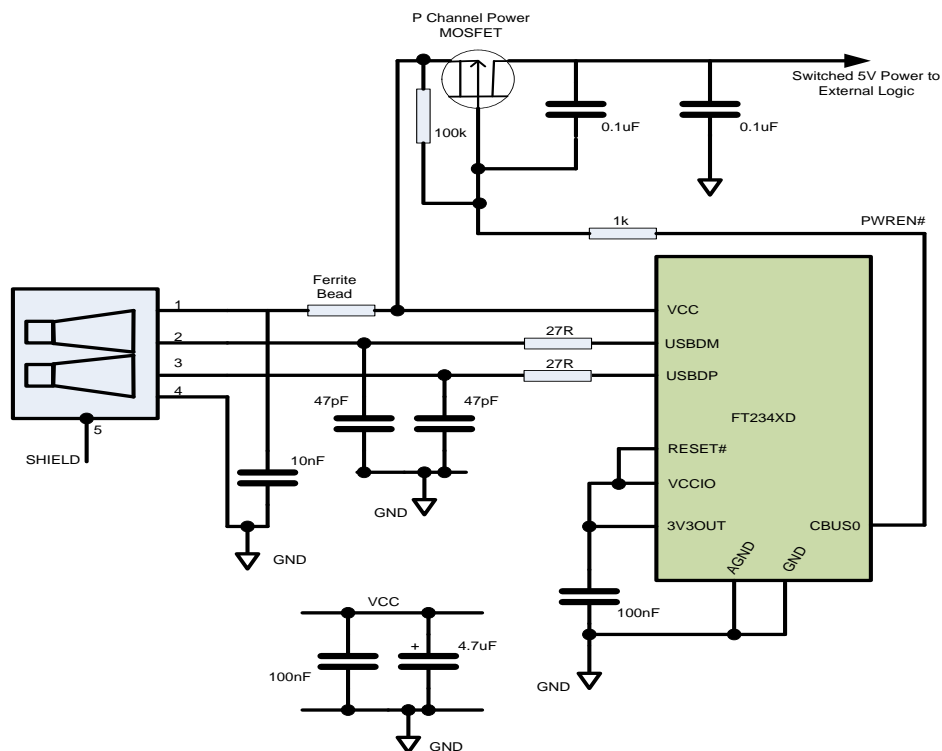

Figure 6.3 Bus Powered with Power Switching Configuration

A requirement of USB bus powered applications, is when in USB suspend mode, the application draws a total current of less than 2.5mA. This requirement includes external logic. Some external logic has the ability to power itself down into a low current state by monitoring the PWREN# signal. For external logic that cannot power itself down in this way, the FT234XD provides a simple but effective method of turning off power during the USB suspend mode.

Figure 6.3 shows an example of using a discrete P-Channel MOSFET to control the power to external logic. A suitable device to do this is an International Rectifier (www.irf.com) IRLML6402, or equivalent. It is recommended that a "soft start" circuit consisting of a 1k Ω series resistor and a 0.1 μ F capacitor is used to limit the current surge when the MOSFET turns on. Without the soft start circuit it is possible that the transient power surge, caused when the MOSFET switches on, will reset the FT234XD or the USB host/hub controller. The soft start circuit example shown in Figure 6.3 powers up with a slew rate of approximately 12.5V/ms. Thus supply voltage to external logic transitions from GND to +5V in approximately 400 microseconds.

As an alternative to the MOSFET, a dedicated power switch IC with inbuilt "soft-start" can be used. A suitable power switch IC for such an application is the Micrel (www.micrel.com) MIC2025-2BM or equivalent.

With power switching controlled designs the following should be noted:

- i) The external logic to which the power is being switched should have its own reset circuitry to automatically reset the logic when power is re-applied when moving out of suspend mode.
- ii) Set the Pull-down on Suspend option in the internal FT234XD MTP memory.
- iii) The CBUS0 Pin should be configured as PWREN# in the internal FT234XD MTP memory, and used to switch the power supply to the external circuitry.
- iv) For USB high-power bus powered applications (one that consumes greater than 100mA, and up to 500mA of current from the USB bus), the power consumption of the application must be set in the Max Power field in the internal FT234XD MTP memory. A high-power bus powered application uses the descriptor in the internal FT234XD MTP memory to inform the system of its power requirements.
- v) PWREN# gets its VCC from VCCIO. For designs using 3V3 logic, ensure VCCIO is not powered down using the external logic. In this case use the +3V3OUT.

7 Application Examples

The following sections illustrate possible applications of the FT234XD.

7.1 USB to RS232 Converter

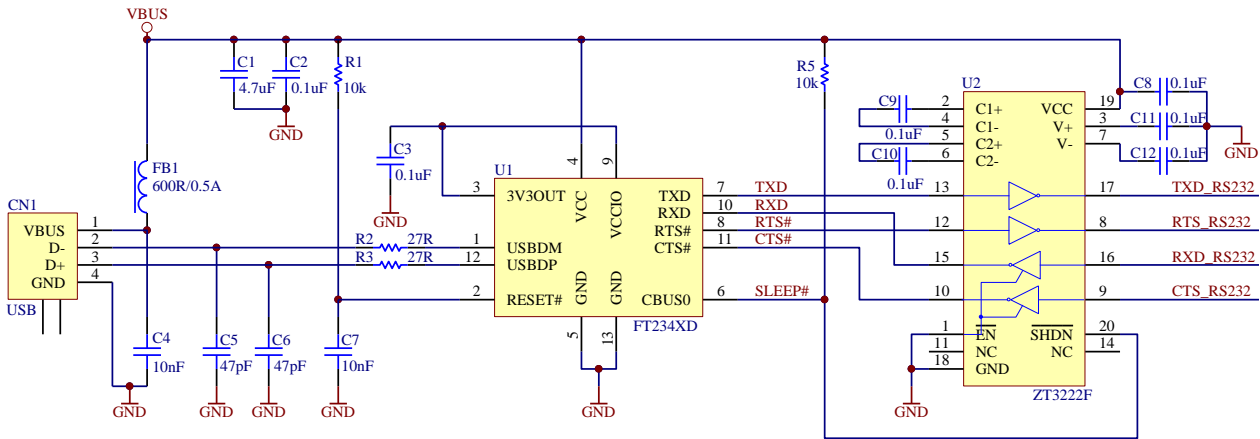

Figure 7.1 Application Example showing USB to RS232 Converter

An example of using the FT234XD as a USB to RS232 converter is illustrated in Figure 7.1. In this application, a 3V3 TTL to RS232 Level Converter IC is used on the serial UART interface of the FT234XD to convert the 3V3 levels of the FT234XD to RS232 levels. This level shift can be done using line drivers from a variety of vendors e.g. Zywyn. A useful feature on some of these devices is the SHDN# pin which can be used to power down the device to a low quiescent current during USB suspend mode.

A suitable level shifting device is the Zywyn ZT3222F which is capable of RS232 communication at up to 1000k baud.

7.2 USB to RS485 Coverter

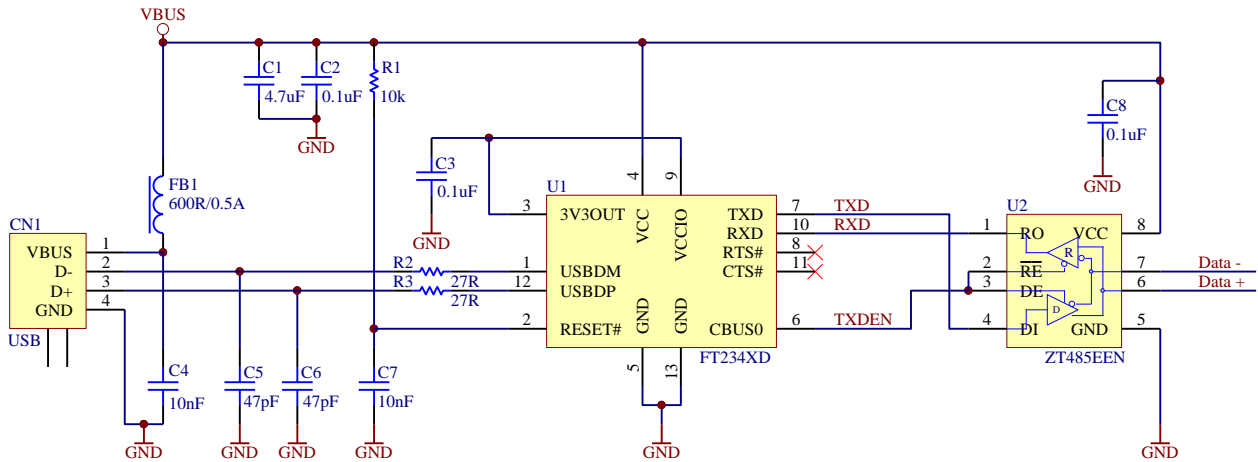

Figure 7.2 Application Example Showing USB to RS485 Converter

An example of using the FT234XD as a USB to RS485 converter is shown in Figure 7.2. In this application, a 3V3-TTL to RS485 level converter IC is used on the serial UART interface of the FT234XD to convert the TTL levels of the FT234XD to RS485 levels.

This example uses the Zywyn ZT485EEN device. Equivalent devices are available from Maxim and Analogue Devices. The ZT485EEN is a RS485 device in a compact 8 pin SOP package. It has separate enables on both the transmitter and receiver. With RS485, the transmitter is only enabled when a character is being transmitted from the UART

The TXDEN signal CBUS pin option on the FT234XD is provided for exactly this purpose and so the transmitter enable is wired to CBUS which has been configured as TXDEN. Note that the TXDEN is activated 1 bit period before the start bit. TXDEN is deactivated at the same time as the stop bit. This is not configurable.

RS485 is a multi-drop network; so many devices can communicate with each other over a two wire cable interface. The RS485 cable requires to be terminated at each end of the cable. A link (which provides the 120Ω termination) allows the cable to be terminated if the ZT485 is physically positioned at either end of the cable.

7.3 USB to RS422 Converter

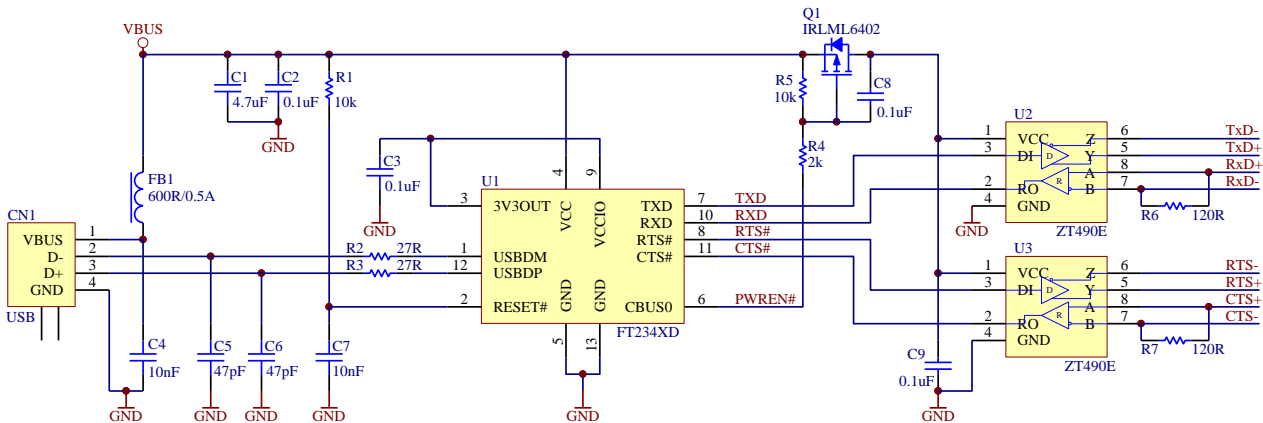

Figure 7.3 USB to RS422 Converter Configuration

An example of using the FT234XD as a USB to RS422 converter is shown in Figure 7.3. In this application, two TTL to RS422 Level Converter ICs are used on the serial UART interface of the FT234XD to convert the TTL levels of the FT234XD to RS422 levels. There are many suitable level converter devices available. This example uses Zynw ZT490E devices. P-Channel MOSFET connected in the VCC line of ZT490E ensures that USB standby current of 2.5mA is not exceeded.

The ZT490E is specified to transmit and receive data at a rate of up to 10 Mbaud. In this example the maximum data rate is limited to 3 Mbaud by the FT234XD.

7.4 USB Battery Charging Detection

A recent addition to the USB specification (http://www.usb.org/developers/devclass_docs/BCv1.2_011912.zip) is to allow for additional charging profiles to be used for charging batteries in portable devices. These charging profiles do not enumerate the USB port of the peripheral. The FT234XD device will detect that a USB compliant dedicated charging port (DCP) is connected. Once detected while in suspend mode, a battery charge detection signal is provided to allow external logic to switch to charging mode as opposed to operation mode.

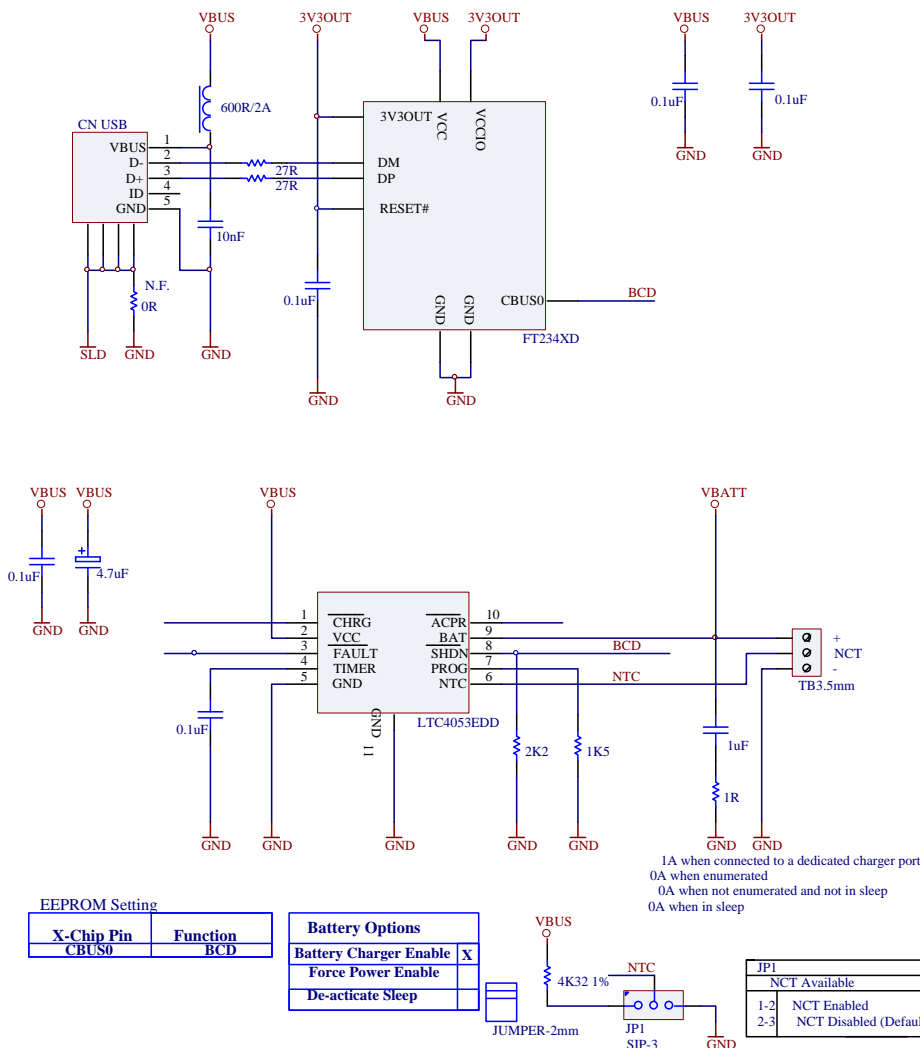

Figure 7.4 USB Battery Charging Detection

To use the FT234XD with battery charging detection the CBUS0 pin must be reprogrammed to allow for the BCD Charger output to switch the external charger circuitry on. The CBUS0 pin is configured in the internal MTP memory with the free utility FT_PROG. If the charging circuitry requires an active low signal to enable it, the CBUS0 pin can be programmed to BCD Charger# as an alternative.

When connected to a USB compliant dedicated charging port (DCP, as opposed to a standard USB host) the device USB signals will be shorted together and the device suspended. The BCD charger signal will bring the LTC4053 out of suspend and allow battery charging to start. The charge current in the example above is 1A as defined by the resistance on the PROG pin.

To calculate the equivalent resistance on the PROG pin select a charge current, then $Res = 1500V/I_{chg}$

For more configuration options of the LTC4053 refer to:

AN_175_Battery Charging Over USB

Note: If the FT234XD is connected to a standard host port such that the device is enumerated the battery charge detection signal is inactive as the device will not be in suspend.

7.5 LED Interface

The CBUS0 I/O pin can be configured to drive an LED. The FT234XD has 3 configuration options for driving LEDs from the CBUS. These are TXLED#, RXLED#, and TX&RXLED#. Refer to Section 3.2 for configuration options.

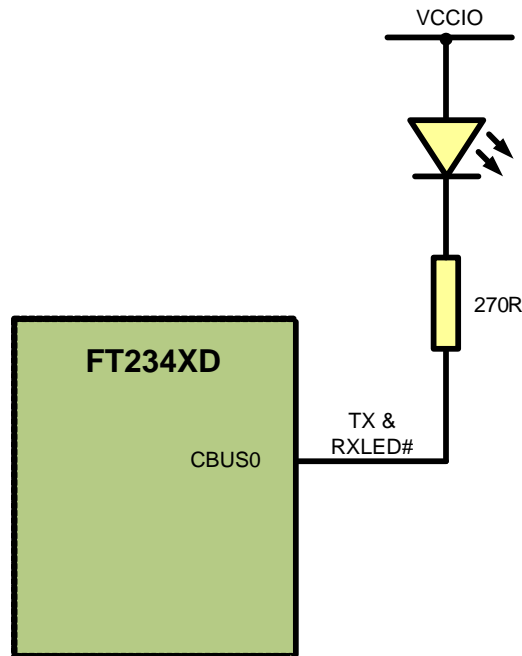

Figure 7.5 Single LED Configuration

An example of using the FT234XD to drive an LED is shown in Figure 7.5. In this example the CBUS0 pin is used to indicate when data is being transmitted or received by the device (TX&RXLED). In this configuration the FT234XD will drive only a single LED.

8 Internal MTP Memory Configuration

The FT234XD includes an internal MTP memory which holds the USB configuration descriptors, other configuration data for the chip and also user data areas. Following a power-on reset or a USB reset the FT234XD will scan its internal MTP memory and read the USB configuration descriptors stored there.

In many cases, the default values programmed into the MTP memory will be suitable and no re-programming will be necessary. The defaults can be found in Section 8.1.

The MTP memory in the FT234XD can be programmed over USB if the values need to be changed for a particular application. Further details of this are provided from section 8.2 onwards.

Users who do not have their own USB Vendor ID but who would like to use a unique Product ID in their design can apply to FTDI for a free block of unique PIDs. See TN_100 – USB Vendor ID/Product ID Guidelines for more details.

8.1 Default Values

The default factory programmed values of the internal MTP memory are shown in Table 8.1.

Parameter	Value	Notes
USB Vendor ID (VID)	0403h	FTDI default VID (hex)
USB Product ID (PID)	6015h	FTDI default PID (hex)
Serial Number Enabled?	Yes	
Serial Number	See Note	A unique serial number is generated and programmed into the MTP memory during device final test.
Pull down I/O Pins in USB Suspend	Disabled	Enabling this option will make the device pull down on the UART interface lines when in USB suspend mode (PWREN# is high).
Manufacturer Name	FTDI	
Product Description	FT234XD BASIC UART	
Max Bus Power Current	90mA	
Power Source	Bus Powered	
Device Type	FT234XD	
USB Version	0200	Returns USB 2.0 device description to the host. Note: The device is a USB 2.0 Full Speed device (12Mb/s) as opposed to a USB 2.0 High Speed device (480Mb/s).
Remote Wake Up	Disabled	Taking RI# low will wake up the USB host controller from suspend in approximately 20 ms.
DBUS Drive Current Strength	4mA	Options are 4mA, 8mA, 12mA, 16mA
DBUS slew rate	Slow	Options are slow or fast
DBUS Schmitt Trigger	Normal	Options are normal or Schmitt

Parameter	Value	Notes
Enable		
CBUS Drive Current Strength	4mA	Options are 4mA, 8mA, 12mA, 16mA
CBUS slew rate	Slow	Options are slow or fast
CBUS Schmitt Trigger Enable	Normal	Options are normal or Schmitt
Load VCP Driver	Enabled**	Makes the device load the VCP driver interface for the device.
CBUS0	TXDEN	Default configuration of CBUS0 – Transmit data enable for RS485
Invert TXD	Disabled	Signal on this pin becomes TXD# if enable.
Invert RXD	Disabled	Signal on this pin becomes RXD# if enable.
Invert RTS#	Disabled	Signal on this pin becomes RTS if enable.
Invert CTS#	Disabled	Signal on this pin becomes CTS if enable.

Table 8.1 Default Internal MTP Memory Configuration

**VCP disabled in Rev B silicon in error

8.2 Methods of Programming the MTP Memory

8.2.1 Programming the MTP memory over USB

The MTP memory on all FT-X devices can be programmed over USB. This method is the same as for the EEPROM on other FTDI devices such as the FT232R. No additional hardware, connections or programming voltages are required. The device is simply connected to the host computer in the same way that it would be for normal applications, and the FT_Prog utility is used to set the required options and program the device.

The FT_Prog utility is provided free-of-charge from the FTDI website, and can be found at the link below. The user guide is also available at this link.

http://www.ftdichip.com/Support/Utilities.htm#FT_Prog

Additionally, D2XX commands can be used to program the MTP memory from within user applications. For more information on the commands available, please see the D2XX Programmers Guide below.

[http://www.ftdichip.com/Support/Documents/ProgramGuides/D2XX_Programmer's_Guide\(FT_00071\).pdf](http://www.ftdichip.com/Support/Documents/ProgramGuides/D2XX_Programmer's_Guide(FT_00071).pdf)

8.3 Memory Map

The FT-X family MTP memory has various areas which come under three main categories:

- User Memory Area
- Configuration Memory Area (writable)
- Configuration Memory Area (non-writable)

Memory Area Description	Word Address
User Memory Area 2 Accessible via USB	0x3FF - 0x80
Configuration Memory Area Accessible via USB	0x7E - 0x50
Configuration Memory Area Cannot be written	0x4E - 0x40
User Memory Area 1 Accessible via USB	0x3E - 0x12
Configuration Memory Area Accessible via USB	0x10 - 0x00

Figure 8.1: Simplified memory map for the FT-X

User Memory Area

The User Memory Areas are highlighted in Green on the memory map. They can be read and written via USB on the FT234XD. All locations within this range are freely programmable; no areas have special functions and there is no checksum for the user area.

Note that the application should take into account the specification for the number of write cycles in Section 5.3 if it will be writing to the MTP memory multiple times.

Configuration Memory Area (writable)

This area stores the configuration data for the device, including the data which is returned to the host in the configuration descriptors (e.g. the VID, PID and string descriptions) and also values which set the hardware configuration (the signal assigned to each CBUS pin for example).

These values can have a significant effect on the behaviour of the device. Steps must be taken to ensure that these locations are not written to un-intentionally by an application which is intended to access only the user area.

This area is included in a checksum which covers configuration areas of the memory, and so changing any value can also cause this checksum to fail.

Configuration Memory Area (non-writable)

This is a reserved area and the application should not write to this area of memory. Any attempt to write these locations will fail

9 Package Parameters

The FT234XD is available in a DFN-12 package. The solder reflow profile is described in Section 9.2.

9.1 DFN-12 Package Mechanical Dimensions

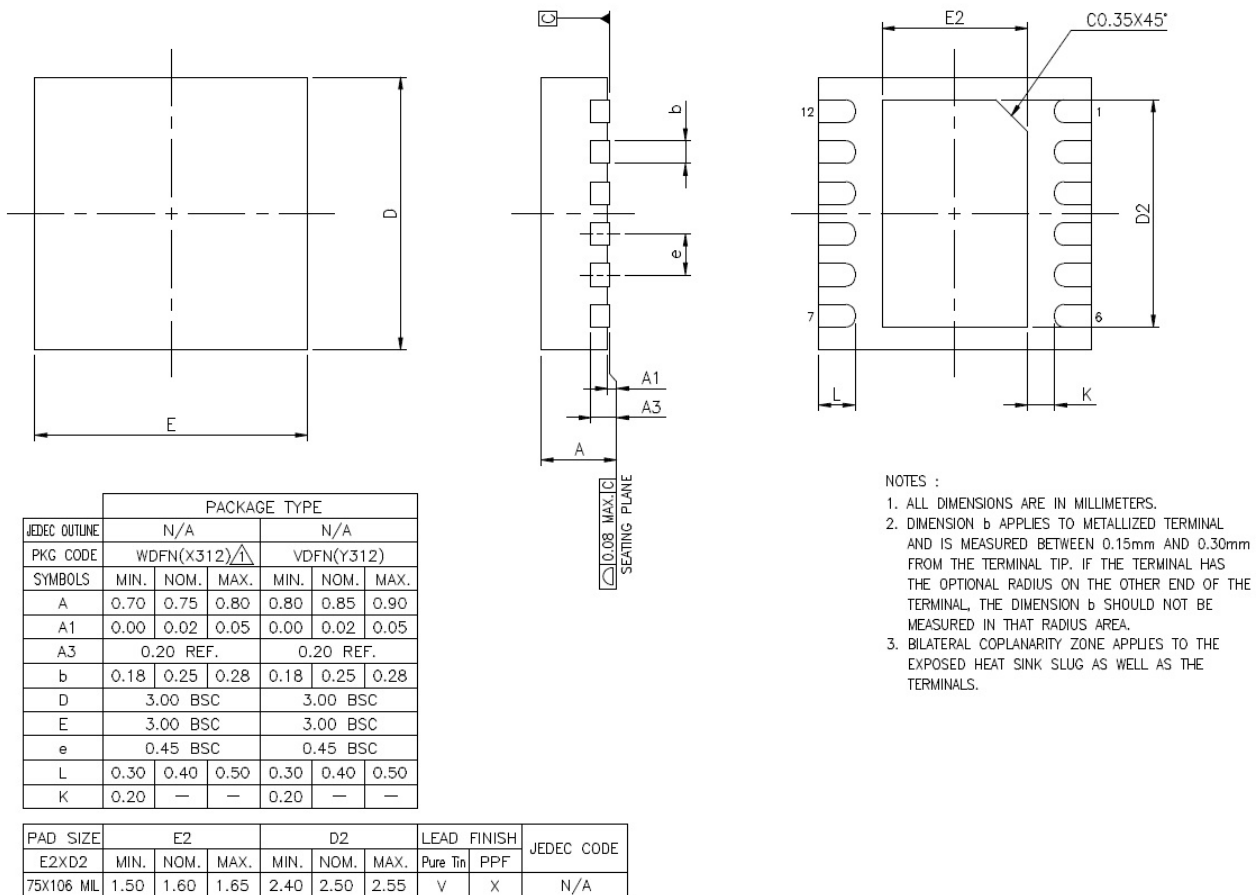

Figure 9.1 DFN-12 Package Dimensions

The FT234XD is supplied in a RoHS compliant leadless DFN-12 package. The package is lead (Pb) free, and uses a 'green' compound. The package is fully compliant with European Union directive 2002/95/EC.

This package is nominally 3.00mm x 3.00mm. The solder pads are on a 0.65mm pitch. The above mechanical drawing shows the DFN-12 package. All dimensions are in millimetres.

The centre pad on the base of the FT234XD is internally connected to ground.

9.2 DFN-12 Package Markings



Figure 9.2 DFN-12 Package Markings

The date code format is **YYXX** where XX = 2 digit week number, YY = 2 digit year number. This is followed by the revision number.

The code **XXXXXXXX** is the manufacturing LOT code.

9.3 Solder Reflow Profile

The FT234XD is supplied in a Pb free DFN-12 package. The recommended solder reflow profile is shown in Figure 9.3.

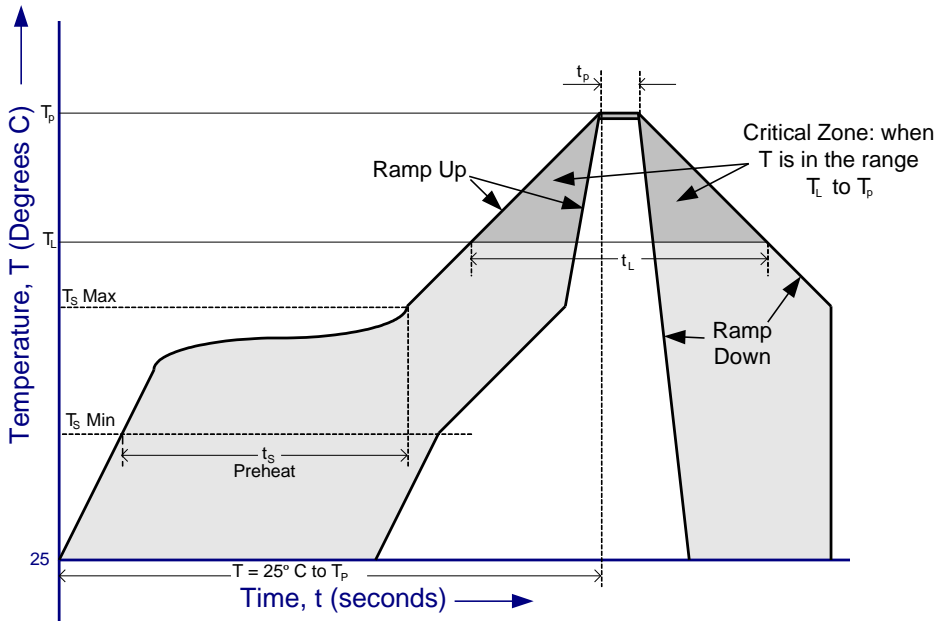

Figure 9.3 FT234XD Solder Reflow Profile

The recommended values for the solder reflow profile are detailed in Table 9.1. Values are shown for both a completely Pb free solder process (i.e. the FT234XD is used with Pb free solder), and for a non-Pb free solder process (i.e. the FT234XD is used with non-Pb free solder).

Profile Feature	Pb Free Solder Process	Non-Pb Free Solder Process
Average Ramp Up Rate (T_s to T_p)	3°C / second Max.	3°C / Second Max.
Preheat - Temperature Min (T_s Min.) - Temperature Max (T_s Max.) - Time (t_s Min to t_s Max)	150°C 200°C 60 to 120 seconds	100°C 150°C 60 to 120 seconds
Time Maintained Above Critical Temperature T_L : - Temperature (T_L) - Time (t_L)	217°C 60 to 150 seconds	183°C 60 to 150 seconds
Peak Temperature (T_p)	260°C	240°C
Time within 5°C of actual Peak Temperature (t_p)	20 to 40 seconds	20 to 40 seconds
Ramp Down Rate	6°C / second Max.	6°C / second Max.
Time for T= 25°C to Peak Temperature, T_p	8 minutes Max.	6 minutes Max.

Table 9.1 Reflow Profile Parameter Values

10 Contact Information

Head Office – Glasgow, UK

Unit 1, 2 Seaward Place, Centurion Business Park
Glasgow G41 1HH
United Kingdom
Tel: +44 (0) 141 429 2777
Fax: +44 (0) 141 429 2758

E-mail (Sales) sales1@ftdichip.com
E-mail (Support) support1@ftdichip.com
E-mail (General Enquiries) admin1@ftdichip.com

Branch Office – Tigard, Oregon, USA

7130 SW Fir Loop,
Tigard, OR 97223
USA
Tel: +1 (503) 547 0988
Fax: +1 (503) 547 0987

E-Mail (Sales) us.sales@ftdichip.com
E-Mail (Support) us.support@ftdichip.com
E-Mail (General Enquiries) us.admin@ftdichip.com

Branch Office – Taipei, Taiwan

2F, No. 516, Sec. 1, NeiHu Road
Taipei 114
Taiwan, R.O.C.
Tel: +886 (0) 2 8791 3570
Fax: +886 (0) 2 8791 3576

E-mail (Sales) tw.sales1@ftdichip.com
E-mail (Support) tw.support1@ftdichip.com
E-mail (General Enquiries) tw.admin1@ftdichip.com

Branch Office – Shanghai, China

Room 408, 317 Xianxia Road,
Shanghai, 200051
China
Tel: +86 21 62351596
Fax: +86 21 62351595

E-mail (Sales) cn.sales@ftdichip.com
E-mail (Support) cn.support@ftdichip.com
E-mail (General Enquiries) cn.admin@ftdichip.com

Web Site

<http://ftdichip.com>

System and equipment manufacturers and designers are responsible to ensure that their systems, and any Future Technology Devices International Ltd (FTDI) devices incorporated in their systems, meet all applicable safety, regulatory and system-level performance requirements. All application-related information in this document (including application descriptions, suggested FTDI devices and other materials) is provided for reference only. While FTDI has taken care to assure it is accurate, this information is subject to customer confirmation, and FTDI disclaims all liability for system designs and for any applications assistance provided by FTDI. Use of FTDI devices in life support and/or safety applications is entirely at the user's risk, and the user agrees to defend, indemnify and hold harmless FTDI from any and all damages, claims, suits or expense resulting from such use. This document is subject to change without notice. No freedom to use patents or other intellectual property rights is implied by the publication of this document. Neither the whole nor any part of the information contained in, or the product described in this document, may be adapted or reproduced in any material or electronic form without the prior written consent of the copyright holder. Future Technology Devices International Ltd, Unit 1, 2 Seaward Place, Centurion Business Park, Glasgow G41 1HH, United Kingdom. Scotland Registered Company Number: SC136640

Appendix A – References

Useful Application Notes

http://www.ftdichip.com/Documents/AppNotes/AN232R-01_FT2302RBitBangModes.pdf

http://www.ftdichip.com/Documents/AppNotes/AN_107_AdvancedDriverOptions_AN_000073.pdf

http://www.ftdichip.com/Documents/AppNotes/AN_121_FTDI_Device_EEPROM_User_Area_Usage.pdf

http://www.ftdichip.com/Documents/AppNotes/AN_120_Aliasing_VCP_Baud_Rates.pdf

[http://www.ftdichip.com/Documents/AppNotes/AN_100_Using_The_FT232_245R_With_External_Osc\(FT_000067\).pdf](http://www.ftdichip.com/Documents/AppNotes/AN_100_Using_The_FT232_245R_With_External_Osc(FT_000067).pdf)

http://www.ftdichip.com/Resources/Utilities/AN_126_User_Guide_For_FT232_Factory%20test%20utility.pdf

http://www.ftdichip.com/Documents/AppNotes/AN232B-05_BaudRates.pdf

<http://www.ftdichip.com/Documents/InstallGuides.htm>

http://www.ftdichip.com/Support/Documents/TechnicalNotes/TN_100_USB_VID-PID_Guidelines.pdf

http://www.ftdichip.com/Support/Documents/AppNotes/AN_175_Battery%20Charging%20Over%20USB%20with%20FTEX%20Devices.pdf

[http://www.ftdichip.com/Support/Documents/ProgramGuides/D2XX_Programmer's_Guide\(FT_000071\).pdf](http://www.ftdichip.com/Support/Documents/ProgramGuides/D2XX_Programmer's_Guide(FT_000071).pdf)

http://www.usb.org/developers/devclass_docs/BCv1.2_011912.zip

Appendix B - List of Figures and Tables

List of Figures

Figure 2.1 FT234XD Block Diagram	4
Figure 3.1 DFN Schematic Symbol	7
Figure 6.1 Bus Powered Configuration	20
Figure 6.2 Self Powered Configuration	21
Figure 6.3 Bus Powered with Power Switching Configuration	22
Figure 7.1 Application Example showing USB to RS232 Converter	23
Figure 7.2 Application Example Showing USB to RS485 Converter	24
Figure 7.3 USB to RS422 Converter Configuration.....	25
Figure 7.4 USB Battery Charging Detection	26
Figure 7.7 Single LED Configuration	27
Figure 8.1: Simplified memory map for the FT-X	30
Figure 9.3 DFN-12 Package Dimensions.....	31
Figure 9.4 DFN-12 Package Markings	32
Figure 9.5 FT234XD Solder Reflow Profile	33

List of Tables

Table 3.1 Power and Ground	7
Table 3.2 Common Function pins	8
Table 3.3 UART Interface and CBUS Group (see note 1)	8
Table 3.4 CBUS Configuration Control	10
Table 5.1 Absolute Maximum Ratings	14
Table 5.2 Operating Voltage and Current	15
Table 5.3 I/O Pin Characteristics VCCIO = +3.3V (except USB PHY pins)	16
Table 5.4 I/O Pin Characteristics VCCIO = +2.5V (except USB PHY pins)	17
Table 5.5 I/O Pin Characteristics VCCIO = +1.8V (except USB PHY pins)	18
Table 5.6 USB I/O Pin (USBDP, USBDM) Characteristics	19
Table 5.7 MTP Memory Characteristics.....	19
Table 5.8 Internal Clock Characteristics	19
Table 8.1 Default Internal MTP Memory Configuration	29
Table 9.1 Reflow Profile Parameter Values	33

Appendix C - Revision History

Document Title: USB to BASIC UART IC FT234XD
Document Reference No.: FT_000753
Clearance No.: FTDI#324
Product Page: <http://www.ftdichip.com/FT-X.htm>
Document Feedback: [Send Feedback](#)

Version 1.0	First release	January 2013
Version 1.1	updated TID info. Added clarification that we are 5V tolerant	February 2013



Компания «ЭлектроПласт» предлагает заключение долгосрочных отношений при поставках импортных электронных компонентов на взаимовыгодных условиях!

Наши преимущества:

- Оперативные поставки широкого спектра электронных компонентов отечественного и импортного производства напрямую от производителей и с крупнейших мировых складов;
- Поставка более 17-ти миллионов наименований электронных компонентов;
- Поставка сложных, дефицитных, либо снятых с производства позиций;
- Оперативные сроки поставки под заказ (от 5 рабочих дней);
- Экспресс доставка в любую точку России;
- Техническая поддержка проекта, помощь в подборе аналогов, поставка прототипов;
- Система менеджмента качества сертифицирована по Международному стандарту ISO 9001;
- Лицензия ФСБ на осуществление работ с использованием сведений, составляющих государственную тайну;
- Поставка специализированных компонентов (Xilinx, Altera, Analog Devices, Intersil, Interpoint, Microsemi, Aeroflex, Peregrine, Syfer, Eurofarad, Texas Instrument, Miteq, Cobham, E2V, MA-COM, Hittite, Mini-Circuits, General Dynamics и др.);

Помимо этого, одним из направлений компании «ЭлектроПласт» является направление «Источники питания». Мы предлагаем Вам помощь Конструкторского отдела:

- Подбор оптимального решения, техническое обоснование при выборе компонента;
- Подбор аналогов;
- Консультации по применению компонента;
- Поставка образцов и прототипов;
- Техническая поддержка проекта;
- Защита от снятия компонента с производства.



Как с нами связаться

Телефон: 8 (812) 309 58 32 (многоканальный)

Факс: 8 (812) 320-02-42

Электронная почта: org@eplast1.ru

Адрес: 198099, г. Санкт-Петербург, ул. Калинина, дом 2, корпус 4, литера А.