



MAX7307 Evaluation Kit/Evaluation System

General Description

The MAX7307 evaluation kit (EV kit) is a fully assembled and tested printed-circuit board (PCB) that demonstrates the capabilities of the MAX7307 4-port level-translating GPIO with latching transition detection, blink, and pulse-width modulation (PWM). The MAX7307 EV kit also includes Windows® 98SE/2000/XP-compatible software that provides a simple graphical user interface (GUI) for exercising the MAX7307's features.

The MAX7307 evaluation system (EV system) includes a MAX7307 EV kit and a Maxim CMAXQUSB serial-interface board.

The CMAXQUSB board connects to a PC's USB port and allows the transfer of I²C commands to the MAX7307 EV kit.

The EV kit comes with the MAX7307ALB+ installed.

Windows is a registered trademark of Microsoft Corp.

Component Lists

MAX7307 EV System

PART	QTY	DESCRIPTION
MAX7307EVKIT+	1	MAX7307 EV kit
CMAXQUSB+	1	Serial-interface board

DESIGNATION	QTY	DESCRIPTION
C1	1	1 μ F \pm 15%, 16V X7R ceramic capacitor (0603) TDK C1608X7R1C105M
C2	1	10 μ F \pm 15%, 10V X5R ceramic capacitor (0805) TDK C2012X5R1A106M
C3	1	0.1 μ F \pm 15%, 25V X7R ceramic capacitor (0603) TDK C1608X7R1E104K
C4	0	Not installed, capacitor (0603)
D1	1	White LED (PLCC-2) OPTEK OVS9WBCR4
D2	1	RGB LED (2.7mm x 2.4mm x 0.95mm) OPTEK OVSTRGBAC6

Features

- ◆ 400kHz 2-Wire Serial Interface, 5.5V Tolerant
- ◆ 1.62V to 3.6V Operation (VDD)
- ◆ 1.4V to 5.5V I/O Level Translation Port Supply (VLA)
- ◆ High Output Sink Current—Up to 25mA per Port
- ◆ Proven PCB Layout
- ◆ Windows 98SE/2000/XP-Compatible Evaluation Software
- ◆ Fully Assembled and Tested
- ◆ EV System Includes USB Connectivity

Ordering Information

PART	TYPE
MAX7307EVKIT+	EV Kit
MAX7307EVCMAXQU+	EV System

+Denotes lead-free and RoHS-compliant.

Note: The MAX7307 EV kit software is designed for use with the complete EV system. The EV system includes both the Maxim CMAXQUSB board and the EV kit. If the Windows software will not be used, the EV kit board can be purchased without the Maxim CMAXQUSB board.

MAX7307 EV Kit

DESIGNATION	QTY	DESCRIPTION
J1	1	2 x 10 right-angle female receptacle
JU1, JU2, JU5	3	3-pin headers
JU3, JU4	2	2-pin headers
R1	1	10k Ω \pm 5% resistor (0603)
R2	1	150 Ω \pm 5% resistor (0603)
R3	1	160 Ω \pm 5% resistor (0603)
R4	1	270 Ω \pm 5% resistor (0603)
R5	1	68 Ω \pm 5% resistor (0603)
R6	1	100k Ω \pm 5% resistor (0603)
R9, R10	0	Not installed, resistors (0603)
R11	1	2k Ω \pm 5% resistor (0603)
S1, S2	2	Pushbutton switches
U1	1	MAX7307ALB+ (10-pin μ DFN)
—	1	PCB: MAX7307 Evaluation Kit+

Evaluate: MAX7307

MAX7307 Evaluation Kit/Evaluation System

Component Suppliers

SUPPLIER	PHONE	WEBSITE
OPTEK Technologies	800-341-4747	www.optekinc.com
TDK Corp.	847-803-6100	www.component.tdk.com

Note: Indicate that you are using the MAX7307 when contacting these component suppliers.

MAX7307 EV Kit Files

FILE	DESCRIPTION
INSTALL.EXE	Installs the EV kit files on your computer
MAX7307.EXE	Application program
FTD2XX.INF	USB device driver file
UNINST.INI	Uninstalls the EV kit software
TROUBLESHOOTING_USB.PDF	USB driver installation help file

Quick Start

Recommended Equipment

- One 5V power supply
- MAX7307 EV system:
 - MAX7307 EV kit
 - Maxim CMAXQUSB interface board (USB cable included)
- A user-supplied Windows 98SE/2000/XP PC with a spare USB port

Note: In the following sections, software-related items are identified by bolding. Text in **bold** refers to items directly from the EV kit software. Text in **bold and underlined** refers to items from the Windows 98SE/2000/XP operating system.

Procedure

The MAX7307 EV kit is fully assembled and tested. Follow the steps below to verify board operation.

Caution: Do not turn on the power supply until all connections are made.

- 1) Visit the Maxim website (www.maxim-ic.com/evkit-software) to download the latest version of the EV kit software, 7307Rxx.ZIP.
- 2) Install the MAX7307 evaluation software on your computer by running the INSTALL.EXE program. The program files are copied and icons are created in the Windows **Start** menu.
- 3) On the CMAXQUSB board, ensure that the shunt of JU1 is in the 3.3V position.
- 4) Enable the I²C pullup resistors on the CMAXQUSB board by setting the DIP switches on SW1 to the ON position.

- 5) For the MAX7307 EV kit, make sure that the shunts of all jumpers are in the following default positions:
 - JU1: (2-3) CMAXQUSB provides the V_{DD} supply
 - JU2: (1-2) P1 drives the white LED D1
 - JU3: (1-2) P2 drives the red LED of D2
 - JU4: (1-2) P3 drives the green LED of D2
 - JU5: (1-2) P4 drives the blue LED of D2
- 6) Carefully align the MAX7307 EV kit's 20-pin connector with the 20-pin connector of the CMAXQUSB board and press them together.
- 7) Connect the 5V power supply between the MAX7307 EV kit's V_{LA} and GND pads.
- 8) Turn on the 5V power supply.
- 9) Connect the USB cable from the PC to the CMAXQUSB board. A **Building Driver Database** window pops up in addition to a **New Hardware Found** message, if this is the first time the program runs on this PC. If you do not see a window that is similar to the one described above after 30s, remove the USB cable from the CMAXQUSB and reconnect it. Administrator privileges are required to install the USB device driver on Windows 2000 and XP. Refer to the TROUBLESHOOTING_USB.PDF document included with the software if you have any problems during this step.
- 10) Follow the directions of the **Add New Hardware Wizard** to install the USB device driver. Choose the **Search for the best driver for your device** option. Specify the location of the device driver to be **C:\Program Files\MAX7307** (default installation directory) using the **Browse** button.

MAX7307 Evaluation Kit/Evaluation System

- 11) Start the MAX7307 EV kit software by opening its icon in the **Start** menu. The GUI main window will appear, as shown in Figure 1.
- 12) Switch to **Port Registers** tab, as shown in Figure 2. Check the **Output** radio button in the **Port Index (0x01 - 0x04)** panel and press the **Write** button. Observe the light change of LED on the EV kit board.

Detailed Description of Software

To start the MAX7307 EV kit software, double-click the MAX7307 EV kit icon that is created during installation. The GUI main window appears as shown in Figure 1.

The user will have to wait approximately 2s while the MAX7307 EV kit software connects to the CMAXUSB board.

There are three tabs on the MAX7307 EV kit GUI window: **Device Configuration Registers**, **Port Registers**, and **Help**.

There is one group box on the MAX7307 EV kit GUI window: **Interrupt Status**.

There are two buttons on the MAX7307 EV kit GUI window: **Reconnect** and **Exit**.

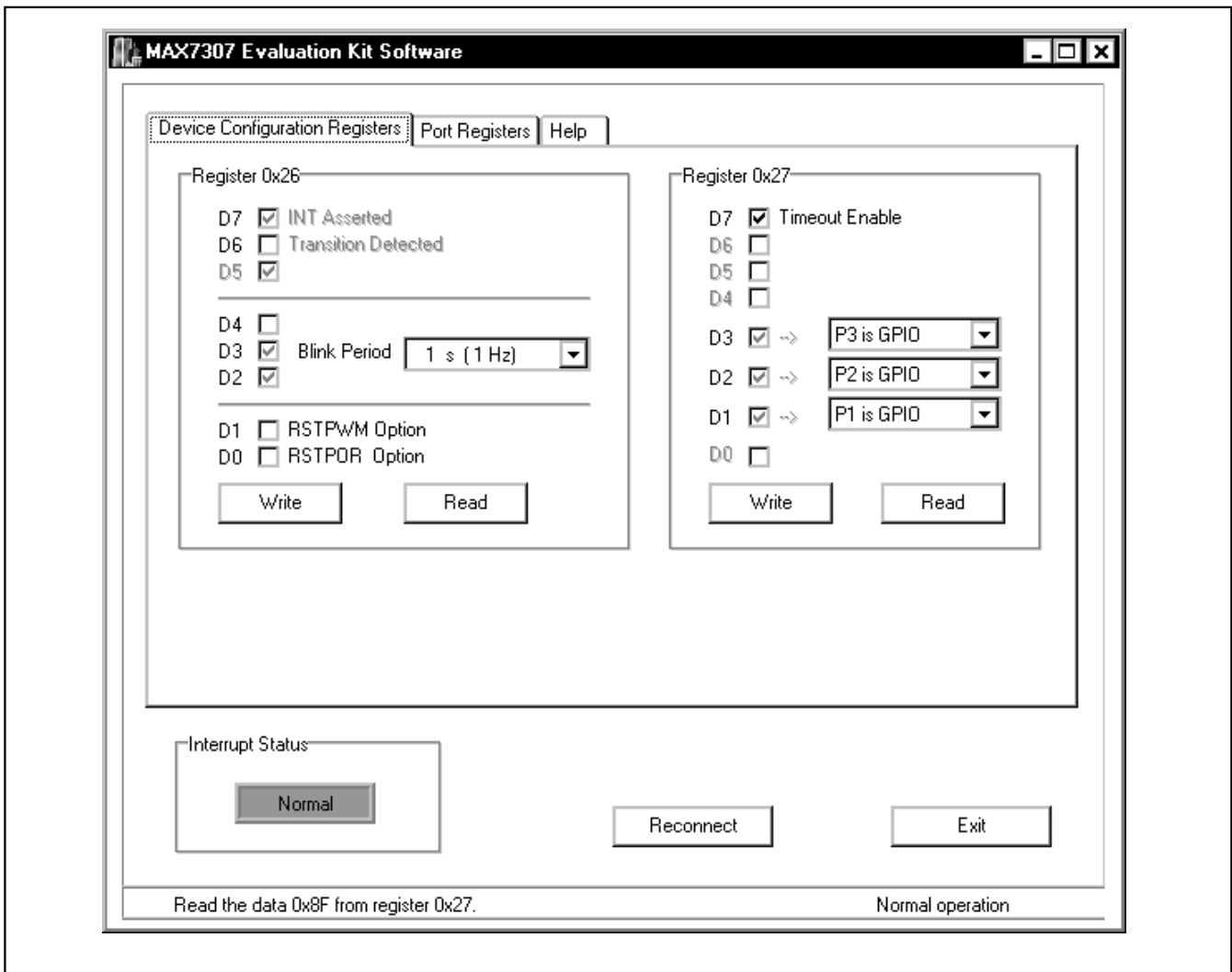

Figure 1. MAX7307 Evaluation Software Main Window (Device Configuration Registers Tab)

MAX7307 Evaluation Kit/Evaluation System

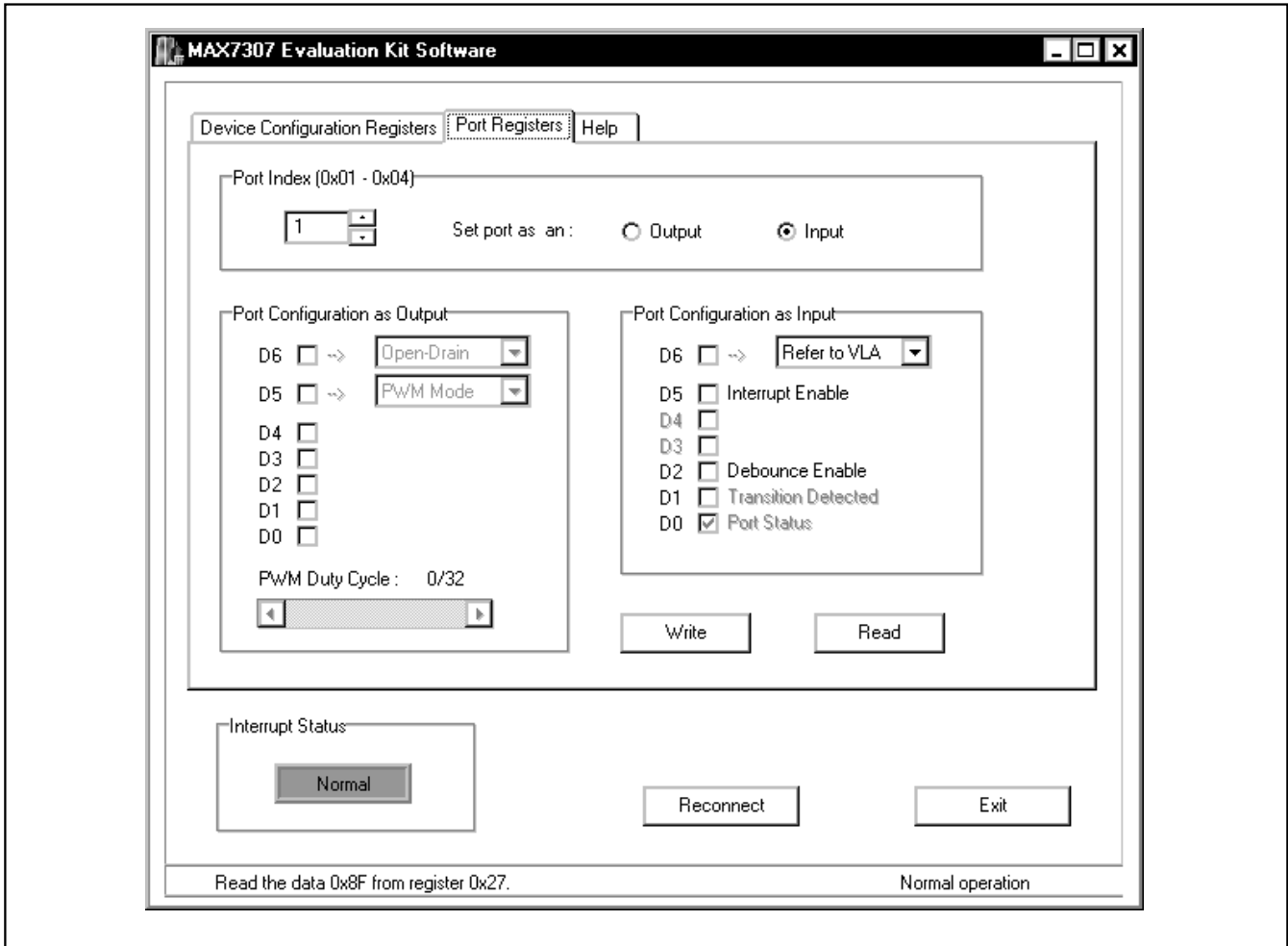

Figure 2. Port Registers Tab

Device Configuration Registers Tab

The **Device Configuration Registers** tab shown in Figure 1 contains two group boxes: **Register 0x26** and **Register 0x27**.

Press the **Read** button inside those two group boxes to read the current setting of the corresponding register. Select the desired setting and press the **Write** button to set the hardware corresponding registers.

Port Registers Tab

The **Port Registers** tab shown in Figure 2 contains the **Port Index (0x01 - 0x04)** group box, **Port Configuration as Output** group box, **Port Configuration as Input** group box, and the **Read** and **Write** buttons.

The **Port Index (0x01 - 0x04)** group box selects the port to be configured; each port can be set as input or output.

Press the **Read** button to read the current device register setting and press the **Write** button to write the new setting to the port register.

Help Tab

The **Help** tab contains the MAX7307 EV kit software version and Maxim's website information.

Interrupt Status Group Box

The **Interrupt Status** group box shows the current status of the MAX7307 INT pin. It detects the latched transition of any port, when the port configured as an input and the interrupt enabled bit is set.

MAX7307 Evaluation Kit/Evaluation System

Evaluate: MAX7307

Reconnect and Exit Buttons

Press the **Reconnect** button to reestablish the connection between the EV kit GUI software and MAX7307 EV kit hardware.

Press the **Exit** button to quit the MAX7307 EV kit GUI software.

Detailed Description of Hardware

The MAX7307 is a 4-port level-translating GPIO with latching transition detection, blink, and PWM. The MAX7307 EV kit board provides a proven layout for evaluating the MAX7307. The EV kit comes with a MAX7307ALB+ installed.

Hardware Reset

Press pushbutton S2 to void current I²C transaction involving the MAX7307. It has the option of resetting the registers to power-up condition, resetting the PWM, and the blink-timing counter. Refer to the MAX7307 IC data sheet for more details on the reset function.

I²C Address

The MAX7307 uses fixed I²C slave address 0x98 (1001100x).

Jumper Settings of I/O Ports Configuration

Jumpers JU2–JU5 are used to configure the MAX7307 I/O ports. Table 1 shows the detailed function of each jumper.

Power Supplies

The I/O level translation port supply (VLA) must be powered by a user-supplied 1.4V to 5.5V power supply. The MAX7307 chip supply (VDD) can either be powered from the CMAXQUSB (2.5V or 3.3V) or from a user-supplied 1.62V to 3.6V power supply connecting to VCC, as shown in Table 2. If an external power supply is used, make sure that the supplied voltage is compatible with the CMAXQUSB JU1 setting.

Table 1. Jumpers JU2–JU5 Configuration

JUMPER	SHUNT POSITION	DESCRIPTION
JU2	1-2*	P1 drives the white LED D1
	2-3	P1 functions as $\overline{\text{INT}}$
	Open	Use P1/INT pad to evaluate P1/INT pin
JU3	1-2*	P2 drives the red LED of D2
	Open	Use P2/OSCIN pad to evaluate P2/OSCIN pin
JU4	1-2*	P3 drives the green LED of D2
	Open	Use P3/OSCOUT pad to evaluate P3/OSCOUT pin
JU5	1-2*	P4 drives the blue LED of D2
	2-3	Use P4 as an input
	Open	Use P4 pad to evaluate P4 pin

*Default position.

Table 2. VDD Selection Configuration

JUMPER	SHUNT POSITION	DESCRIPTION
JU1	1-2	User-supplied 1.62V to 3.6V power supply (VCC)
	2-3*	Powered by CMAXQUSB

*Default position.

User-Supplied I²C Interface

To use the MAX7307 EV kit with a user-supplied I²C interface, install the shunt on jumper JU1's 1-2 position and remove the CMAXQUSB board. Connect SDA, SCL, and GND lines from the user-supplied I²C interface to the SDA, SCL, and GND pads on the MAX7307 EV kit. Apply a 1.62V to 3.6V power supply to the VCC pad of the MAX7307 EV kit. Depending on the configuration of the user-supplied I²C interface, it may be necessary to install I²C pullup resistors R9 and R10.

MAX7307 Evaluation Kit/Evaluation System

Evaluate: MAX7307

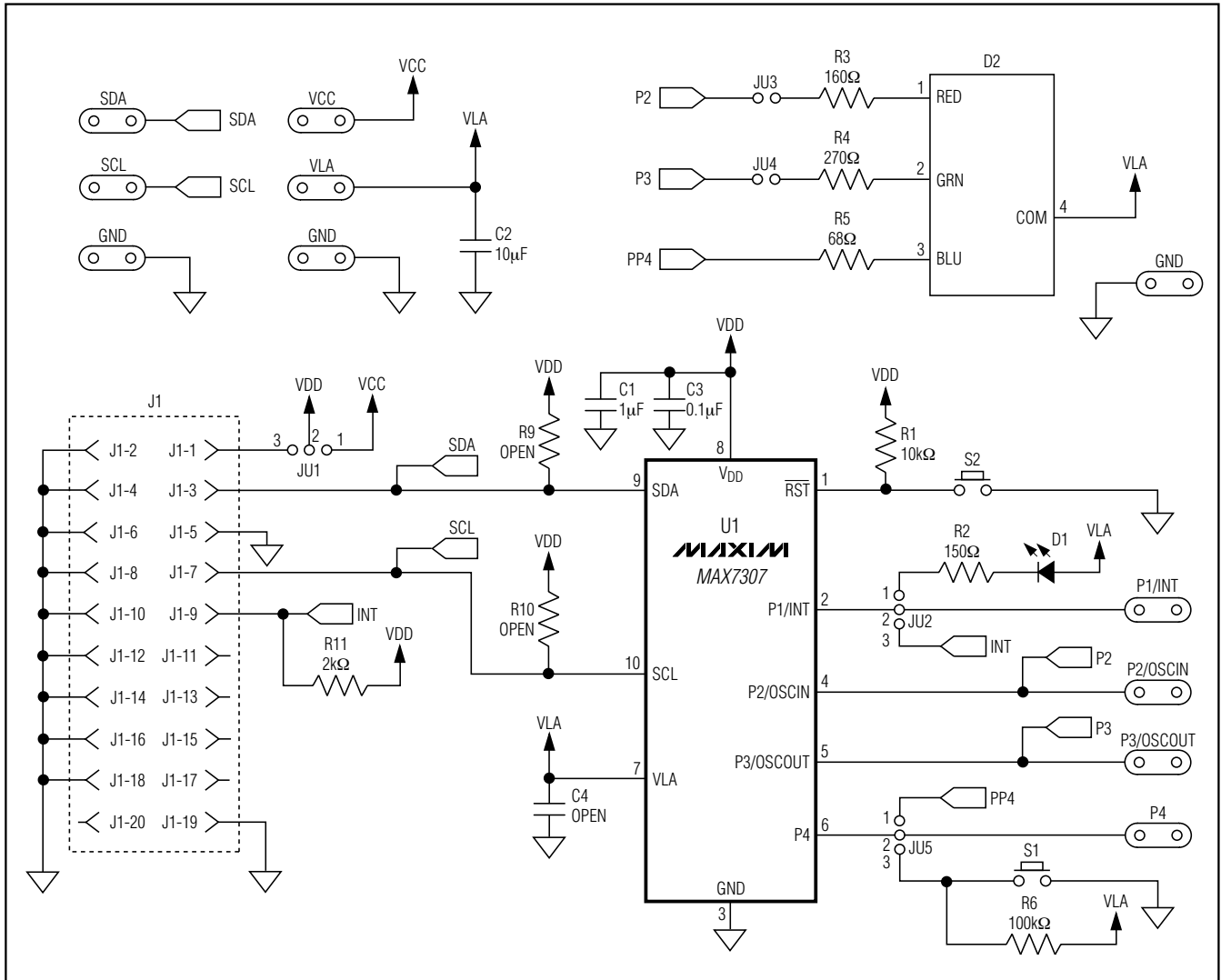

Figure 3. MAX7307 EV Kit Schematic

MAX7307 Evaluation Kit/Evaluation System

Evaluate: MAX7307

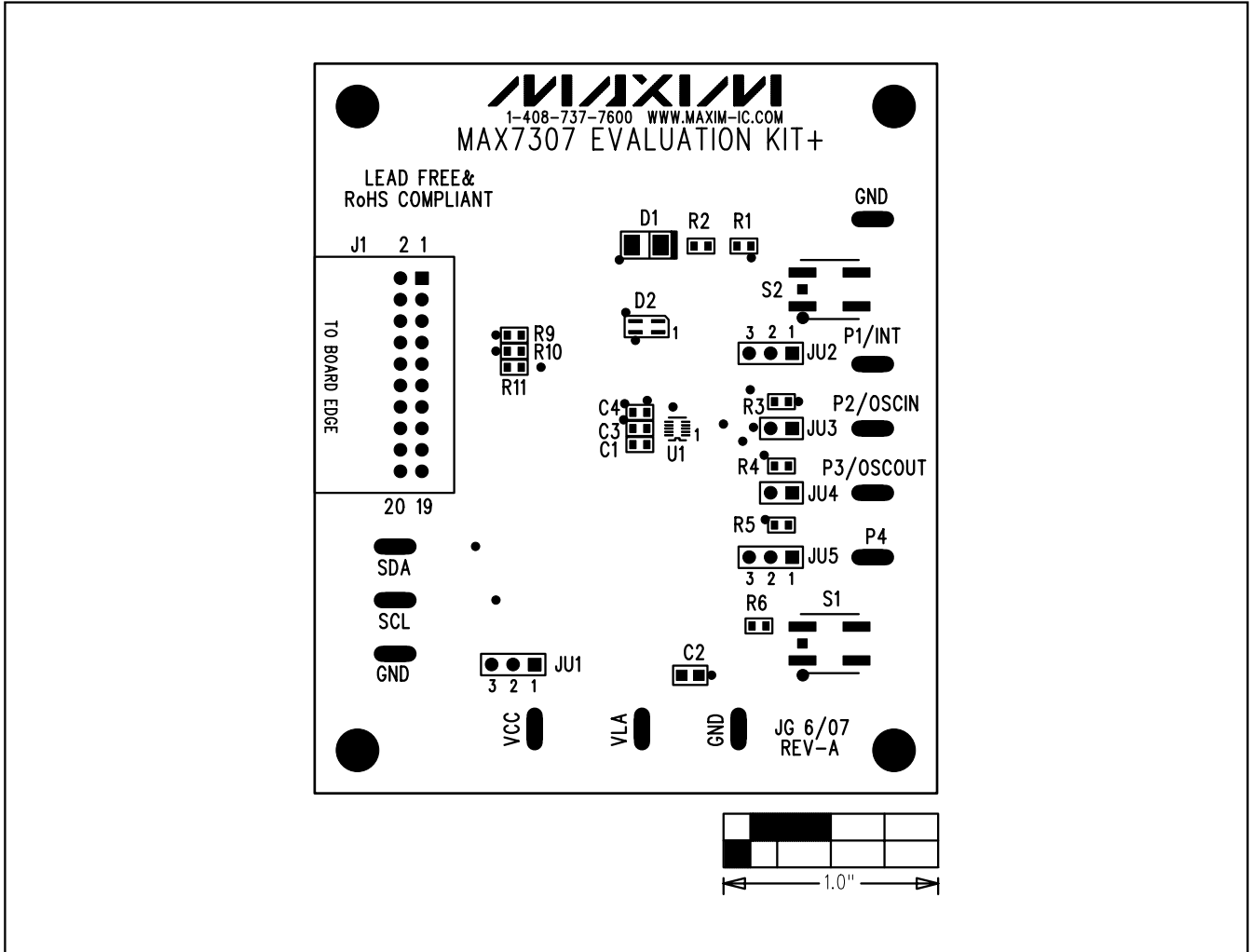

Figure 4. MAX7307 EV Kit Component Placement Guide—Component Side

MAX7307 Evaluation Kit/Evaluation System

Evaluate: MAX7307

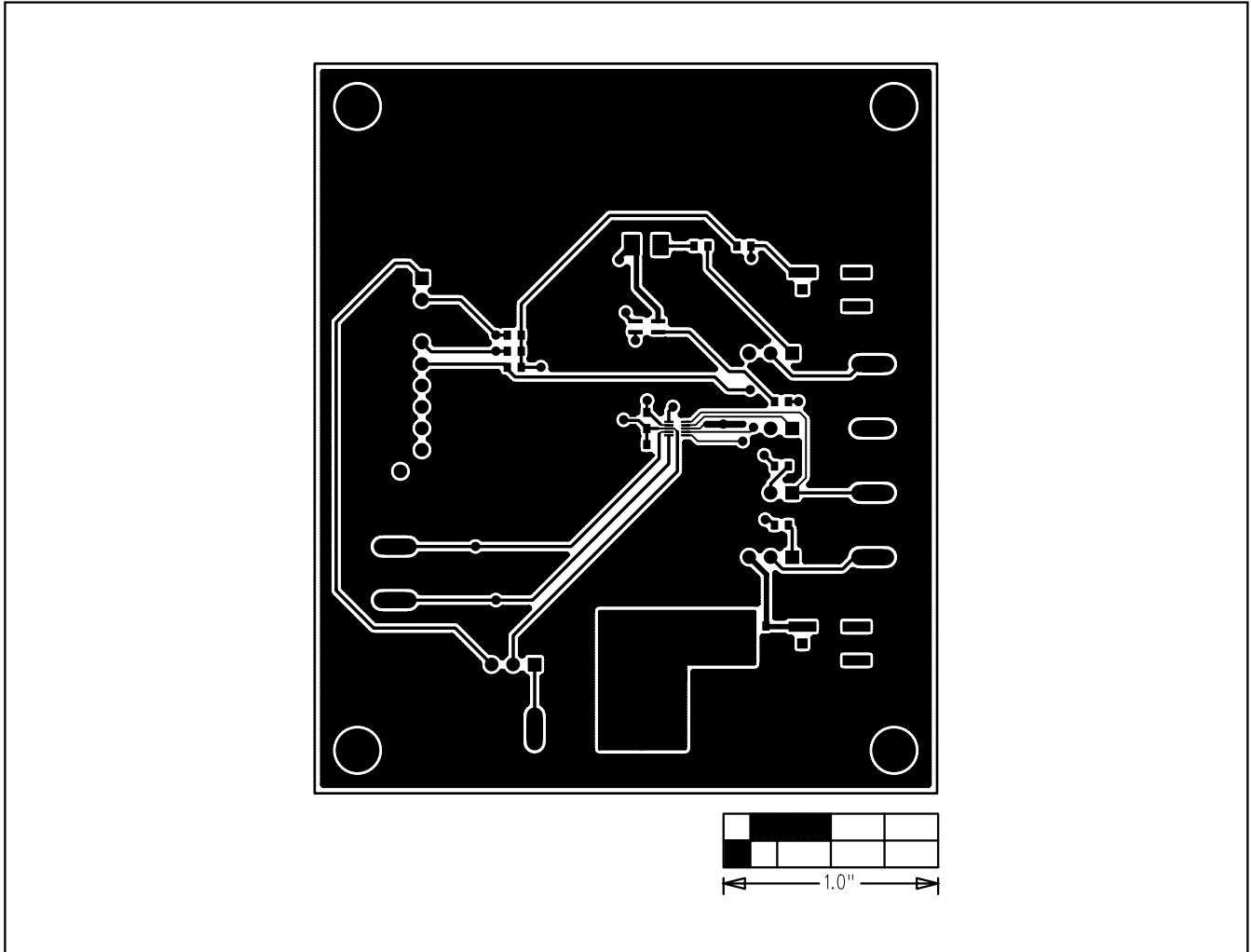

Figure 5. MAX7307 EV Kit PCB Layout—Component Side

MAX7307 Evaluation Kit/Evaluation System

Evaluate: MAX7307

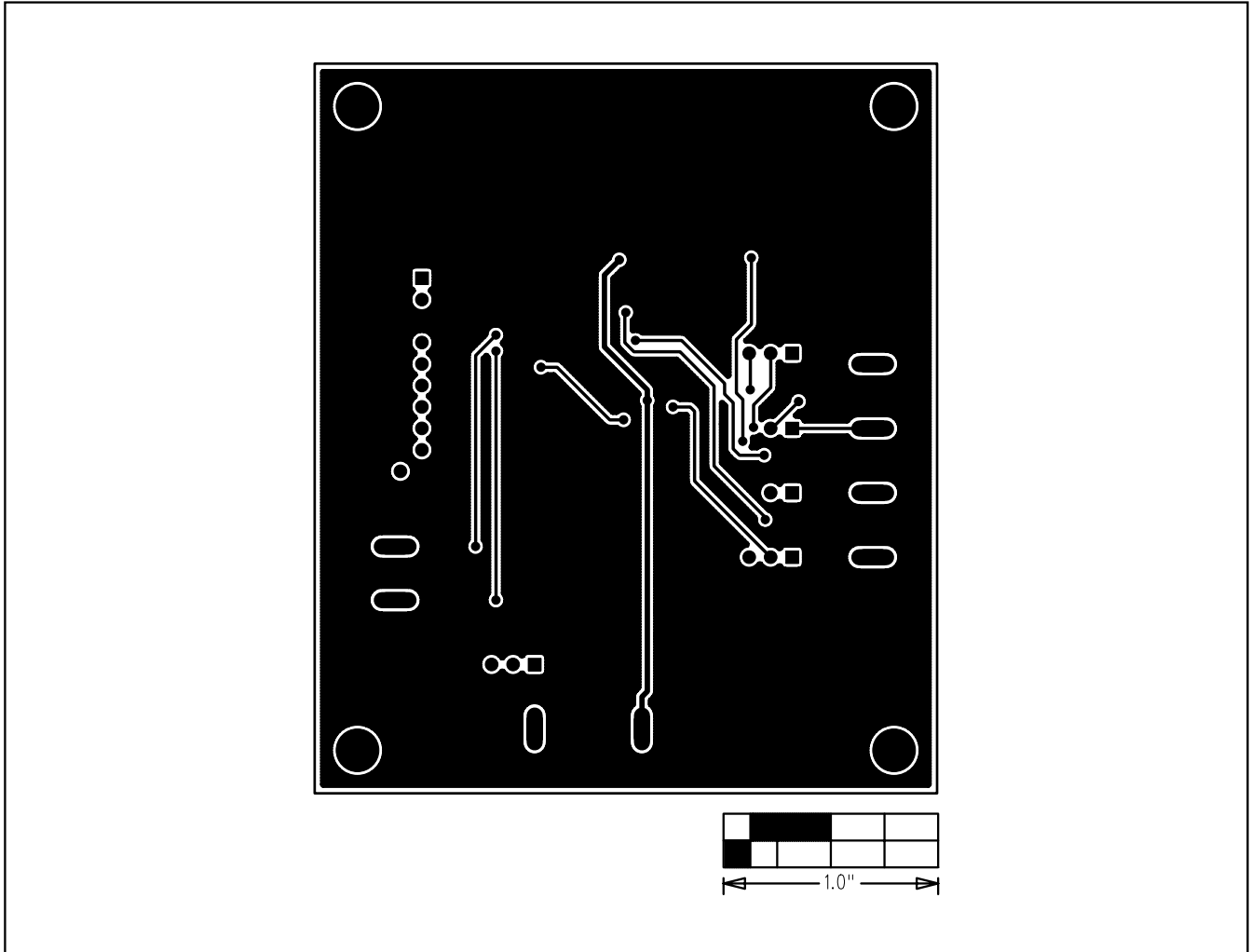

Figure 6. MAX7307 EV Kit PCB Layout—Solder Side

Maxim cannot assume responsibility for use of any circuitry other than circuitry entirely embodied in a Maxim product. No circuit patent licenses are implied. Maxim reserves the right to change the circuitry and specifications without notice at any time.

Maxim Integrated Products, 120 San Gabriel Drive, Sunnyvale, CA 94086 408-737-7600 _____ **9**



Компания «ЭлектроПласт» предлагает заключение долгосрочных отношений при поставках импортных электронных компонентов на взаимовыгодных условиях!

Наши преимущества:

- Оперативные поставки широкого спектра электронных компонентов отечественного и импортного производства напрямую от производителей и с крупнейших мировых складов;
- Поставка более 17-ти миллионов наименований электронных компонентов;
- Поставка сложных, дефицитных, либо снятых с производства позиций;
- Оперативные сроки поставки под заказ (от 5 рабочих дней);
- Экспресс доставка в любую точку России;
- Техническая поддержка проекта, помощь в подборе аналогов, поставка прототипов;
- Система менеджмента качества сертифицирована по Международному стандарту ISO 9001;
- Лицензия ФСБ на осуществление работ с использованием сведений, составляющих государственную тайну;
- Поставка специализированных компонентов (Xilinx, Altera, Analog Devices, Intersil, Interpoint, Microsemi, Aeroflex, Peregrine, Syfer, Eurofarad, Texas Instrument, Miteq, Cobham, E2V, MA-COM, Hittite, Mini-Circuits, General Dynamics и др.);

Помимо этого, одним из направлений компании «ЭлектроПласт» является направление «Источники питания». Мы предлагаем Вам помощь Конструкторского отдела:

- Подбор оптимального решения, техническое обоснование при выборе компонента;
- Подбор аналогов;
- Консультации по применению компонента;
- Поставка образцов и прототипов;
- Техническая поддержка проекта;
- Защита от снятия компонента с производства.



Как с нами связаться

Телефон: 8 (812) 309 58 32 (многоканальный)

Факс: 8 (812) 320-02-42

Электронная почта: org@eplast1.ru

Адрес: 198099, г. Санкт-Петербург, ул. Калинина, дом 2, корпус 4, литера А.