

# MAAM-007501-SA2002



## Surface Mount TO-8 Cascadable Amplifier 20 to 2700 MHz

Rev. V3

### Features

- LOW NOISE FIGURE: 2.5 dB (TYP.)
- OUTPUT POWER: +27 dBm (TYP.)
- HIGH THIRD ORDER IP: +40.0 dBm (TYP.)

### Description

The MAAM-007501-SA2002 amplifier is a discrete hybrid design, which uses thin film manufacturing processes for accurate performance and high reliability. This single stage PHEMT feedback amplifier design displays impressive performance over a broadband frequency range. The design also incorporates the use of an impedance transformer, and an RF choke is used for power supply decoupling. The Surface Mount package is hermetically sealed, and MIL-STD-883 environmental screening is available.

### Product Image

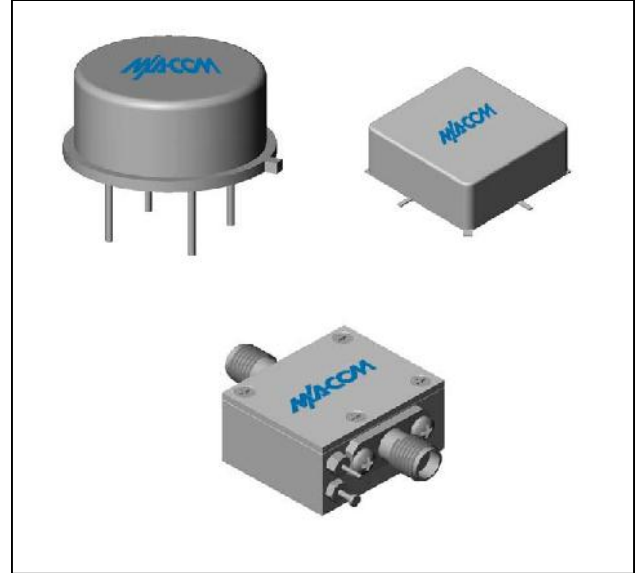

### Ordering Information

Part Number	Package
MAAM-007501-0A2002	TO-8
MAAM-007501-SA2002	Surface Mount
MAAM-007501-CA2002	SMA Connectorized **

\*\* The connectorized version is not RoHs compliant.

### Electrical Specifications: $Z_0 = 50\Omega$ , $V_{CC} = +9 V_{DC}$

Parameter	Units	Typical	Guaranteed	
		25°C	0° to 50°C	-40° to +85°C*
Frequency	MHz	20-2700	20-2700	20-2700
Small Signal Gain (min)	dB	11.5	10.0	9.5
Gain Flatness (max)	dB	+/- 0.4	+/- 0.7	+/- 1.0
Noise Figure (max)	dB	2.5	4.0	5.0
Power Output @ 1 dB comp. (min)	dBm	+27.0	+25.0	+23.5
IP3	dBm	+40.0		
IP2	dBm	+55.0		
VSWR Input / Output (max)		1.7:1 / 1.7:1	2.0:1 / 2.0:1	2.2:1 / 2.2:1
DC Current @ 9 Volts (max)	mA	165	195	225

### Absolute Maximum Ratings

Parameter	Absolute Maximum
Storage Temperature	-62°C to +125°C
Case Temperature	+85°C
DC Voltage	+12 V
Continuous Input Power	+17 dBm
Short Term Input power (1 minute max.)	50 mW
Peak Power (3 $\mu$ sec max.)	0.5 W
"S" Series Burn-In Temperature (case)	+85°C

### Thermal Data: $V_{CC} = +9 V_{DC}$

Parameter	Rating
Thermal Resistance $\theta_{jc}$	+51°C/W
Transistor Power Dissipation $P_d$	1.2 W
Junction Temperature Rise Above Case $T_{jc}$	+61°C

\* Over temperature performance limits for part number MAAM-007501-CA2002, guaranteed from 0°C to +50°C only.

1

**ADVANCED:** Data Sheets contain information regarding a product M/A-COM Technology Solutions is considering for development. Performance is based on target specifications, simulated results, and/or prototype measurements. Commitment to develop is not guaranteed.

**PRELIMINARY:** Data Sheets contain information regarding a product M/A-COM Technology Solutions has under development. Performance is based on engineering tests. Specifications are typical. Mechanical outline has been fixed. Engineering samples and/or test data may be available. Commitment to produce in volume is not guaranteed.

• **North America** Tel: 800.366.2266 • **Europe** Tel: +353.21.244.6400  
 • **India** Tel: +91.80.4155721 • **China** Tel: +86.21.2407.1588  
 Visit [www.macomtech.com](http://www.macomtech.com) for additional data sheets and product information.

M/A-COM Technology Solutions Inc. and its affiliates reserve the right to make changes to the product(s) or information contained herein without notice.

## Surface Mount TO-8 Cascadable Amplifier 20 to 2700 MHz

Rev. V3

### Typical Performance Curves at +25°C

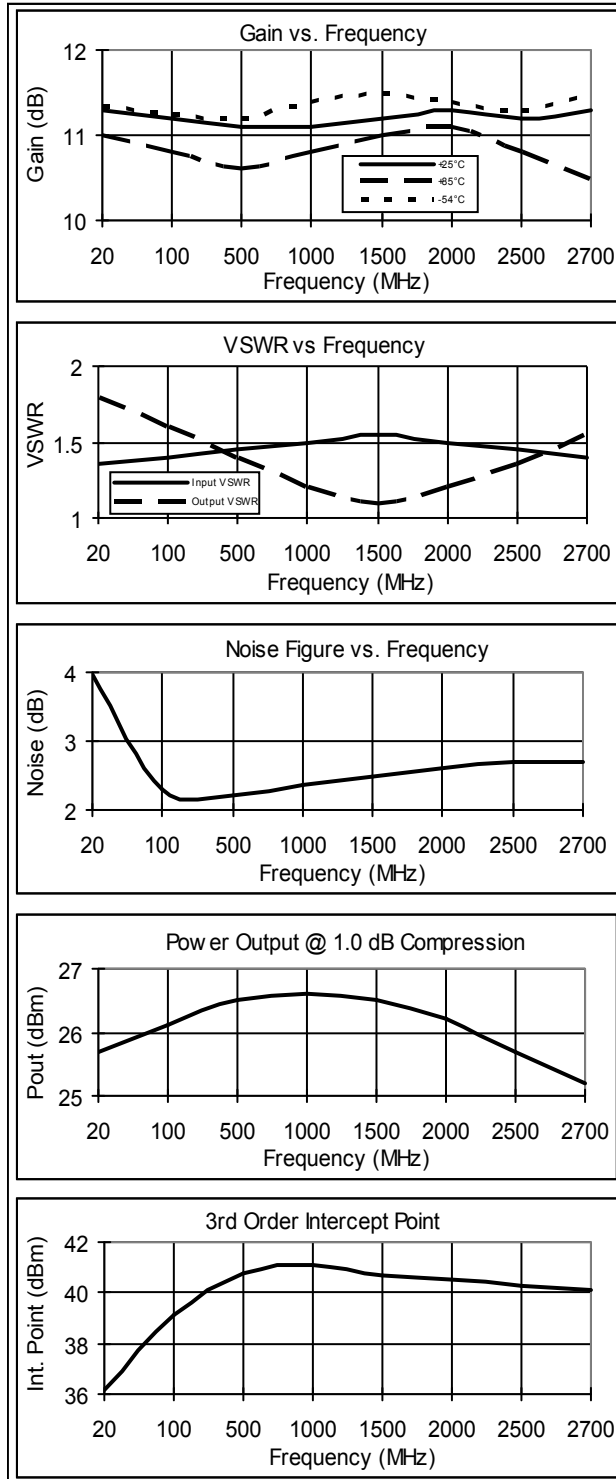

### Outline Drawing: TO-8 \*

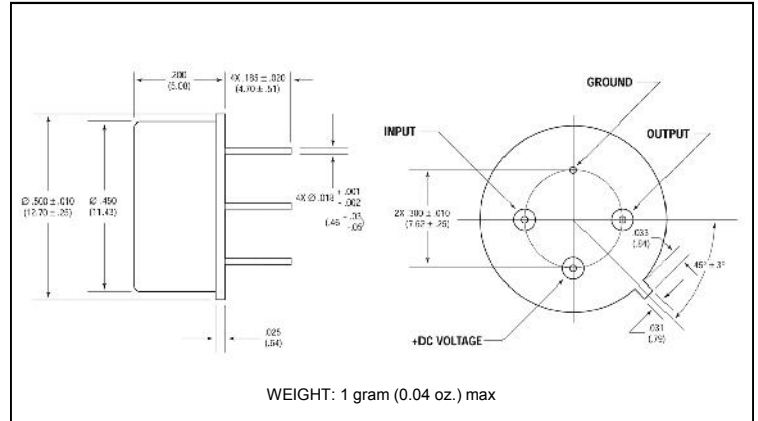

### Outline Drawing: Surface Mount \*

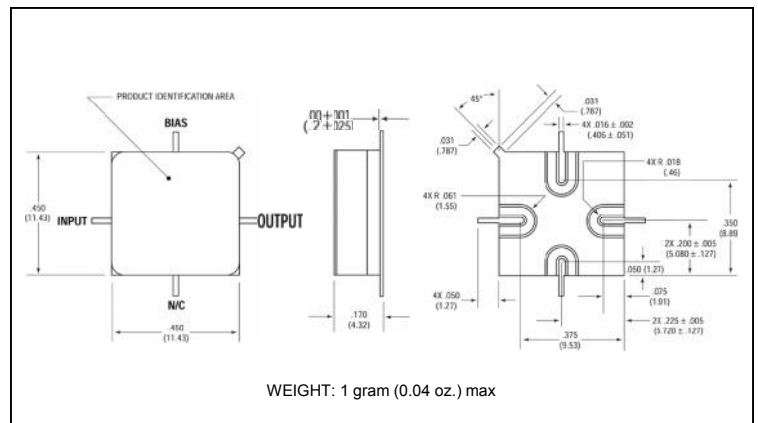

### Outline Drawing: SMA Connectorized \*

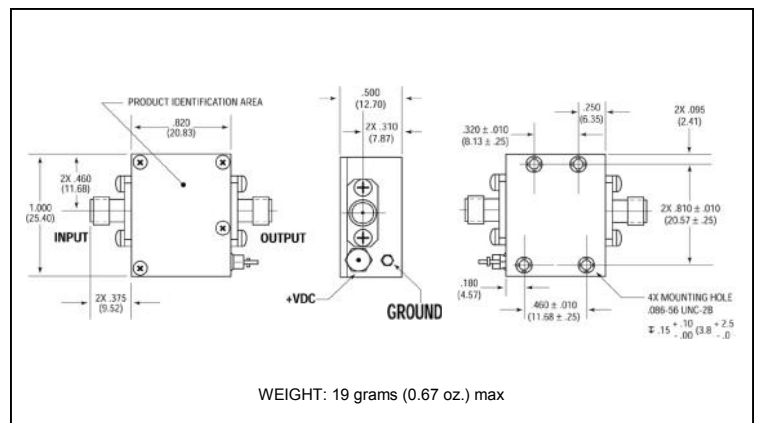

\* Dimensions are inches (millimeters) ±0.015 (0.38) unless otherwise specified.

**ADVANCED:** Data Sheets contain information regarding a product M/A-COM Technology Solutions is considering for development. Performance is based on target specifications, simulated results, and/or prototype measurements. Commitment to develop is not guaranteed.  
**PRELIMINARY:** Data Sheets contain information regarding a product M/A-COM Technology Solutions has under development. Performance is based on engineering tests. Specifications are typical. Mechanical outline has been fixed. Engineering samples and/or test data may be available. Commitment to produce in volume is not guaranteed.

• **North America** Tel: 800.366.2266 • **Europe** Tel: +353.21.244.6400  
 • **India** Tel: +91.80.4155721 • **China** Tel: +86.21.2407.1588  
 Visit [www.macomtech.com](http://www.macomtech.com) for additional data sheets and product information.

M/A-COM Technology Solutions Inc. and its affiliates reserve the right to make changes to the product(s) or information contained herein without notice.



Компания «ЭлектроПласт» предлагает заключение долгосрочных отношений при поставках импортных электронных компонентов на взаимовыгодных условиях!

Наши преимущества:

- Оперативные поставки широкого спектра электронных компонентов отечественного и импортного производства напрямую от производителей и с крупнейших мировых складов;
- Поставка более 17-ти миллионов наименований электронных компонентов;
- Поставка сложных, дефицитных, либо снятых с производства позиций;
- Оперативные сроки поставки под заказ (от 5 рабочих дней);
- Экспресс доставка в любую точку России;
- Техническая поддержка проекта, помощь в подборе аналогов, поставка прототипов;
- Система менеджмента качества сертифицирована по Международному стандарту ISO 9001;
- Лицензия ФСБ на осуществление работ с использованием сведений, составляющих государственную тайну;
- Поставка специализированных компонентов (Xilinx, Altera, Analog Devices, Intersil, Interpoint, Microsemi, Aeroflex, Peregrine, Syfer, Eurofarad, Texas Instrument, Miteq, Cobham, E2V, MA-COM, Hittite, Mini-Circuits, General Dynamics и др.);

Помимо этого, одним из направлений компании «ЭлектроПласт» является направление «Источники питания». Мы предлагаем Вам помощь Конструкторского отдела:

- Подбор оптимального решения, техническое обоснование при выборе компонента;
- Подбор аналогов;
- Консультации по применению компонента;
- Поставка образцов и прототипов;
- Техническая поддержка проекта;
- Защита от снятия компонента с производства.



#### Как с нами связаться

**Телефон:** 8 (812) 309 58 32 (многоканальный)

**Факс:** 8 (812) 320-02-42

**Электронная почта:** [org@eplast1.ru](mailto:org@eplast1.ru)

**Адрес:** 198099, г. Санкт-Петербург, ул. Калинина, дом 2, корпус 4, литера А.