



NTC thermistors for temperature measurement

Leaded NTC thermistors,
lead spacing 5 mm

Series/Type: **B57885S**
Date: February 2009

Applications

- Temperature measurement and compensation

Features

- High measuring accuracy
- Cost-effective
- Rugged design, epoxy resin encapsulation
- Tinned copper leads
- Lead spacing 5 mm

Options

- Flexible coating of head and wires available on request

Delivery mode

Bulk (standard), cardboard tape, reeled or in Ammo pack on request

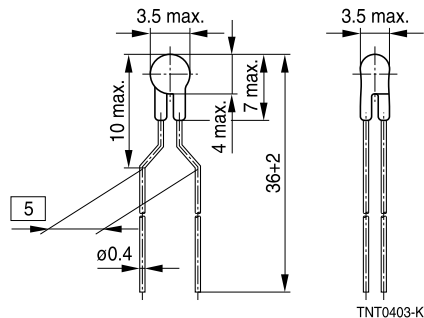
Dimensional drawing

Dimensions in mm
Approx. weight 130 mg

General technical data

Climatic category	(IEC 60068-1)		55/155/56	
Max. power	(at 25 °C)	P_{25}	100	mW
Resistance tolerance		$\Delta R_R/R_R$	$\pm 1, \pm 3, \pm 5$	%
Rated temperature		T_R	25	°C
Dissipation factor	(in air)	δ_{th}	approx. 4	mW/K
Thermal cooling time constant	(in air)	τ_c	approx. 10	s
Heat capacity		C_{th}	approx. 40	mJ/K

Electrical specification and ordering codes

R_{25} Ω	No. of R/T characteristic	$B_{25/100}$ K	Ordering code
2.1 k	1008	3560 ±1%	B57885S0212+000
10 k	2003	3980 ±1%	B57885S0103+001
10 k	2908	3460 ±1%	B57885S0103+002
10 k	2001	3920 ±1%	B57885S0103+003
12 k	2901	3760 ±1%	B57885S0123+000
30 k	8018	3964 ±1%	B57885S0303+000

+ = Resistance tolerance

F = ±1%

H = ±3%

J = ±5%

Reliability data

Test	Standard	Test conditions	$\Delta R_{25}/R_{25}$ (typical)	Remarks
Storage in dry heat	IEC 60068-2-2	Storage at upper category temperature T: 155 °C t: 1000 h	< 2%	No visible damage
Storage in damp heat, steady state	IEC 60068-2-78	Temperature of air: 40 °C Relative humidity of air: 93% Duration: 56 days	< 1%	No visible damage
Rapid temperature cycling	IEC 60068-2-14	Lower test temperature: -55 °C Upper test temperature: 155 °C Number of cycles: 100	< 2%	No visible damage
Endurance		P_{max} : 100 mW t: 1000 h	< 3%	No visible damage
Long-term stability (empirical value)		Temperature: 70 °C t: 10000 h	< 3%	No visible damage

R/T characteristics

B57885S0212F000						
R/T No.	1008					
T (°C)	$B_{25/100} = 3560 \text{ K}$, $R_{25} = 2100 \text{ } \Omega$, $T_R = 25 \text{ } ^\circ\text{C}$, $\Delta R_R/R_R = \pm 1\%$					
	$R_{nom}[\Omega]$	$R_{min}[\Omega]$	$R_{max}[\Omega]$	$\Delta R_R/R_R[\pm\%]$	$\Delta T[\pm^\circ\text{C}]$	$\alpha (\%/K)$
-55.0	111520	105460	117570	5.4	0.9	6.1
-50.0	82567	78386	86747	5.1	0.8	6.0
-45.0	61583	58680	64486	4.7	0.8	5.8
-40.0	46263	44237	48289	4.4	0.8	5.7
-35.0	34999	33579	36420	4.1	0.7	5.5
-30.0	26661	25661	27661	3.8	0.7	5.4
-25.0	20423	19717	21128	3.5	0.7	5.2
-20.0	15786	15285	16287	3.2	0.6	5.1
-15.0	12254	11899	12609	2.9	0.6	4.9
-10.0	9594	9341	9847	2.6	0.5	4.8
-5.0	7570	7390	7751	2.4	0.5	4.7
0.0	6020	5891	6149	2.1	0.5	4.5
5.0	4811	4719	4902	1.9	0.4	4.4
10.0	3872	3807	3937	1.7	0.4	4.3
15.0	3133	3087	3179	1.5	0.4	4.1
20.0	2552	2520	2584	1.3	0.3	4.0
25.0	2100	2079	2121	1.0	0.3	3.9
30.0	1742	1721	1764	1.2	0.3	3.8
35.0	1441	1421	1462	1.4	0.4	3.7
40.0	1199	1180	1219	1.6	0.5	3.6
45.0	1008	990.2	1026	1.8	0.5	3.5
50.0	851.4	834.6	868.2	2.0	0.6	3.4

B57885S0212F000						
R/T No.	1008					
T (°C)	B _{25/100} = 3560 K, R ₂₅ = 2100 Ω, T _R = 25 °C, ΔR _R /R _R = ± 1%					
	R _{nom} [Ω]	R _{min} [Ω]	R _{max} [Ω]	ΔR _R /R _R [±%]	ΔT[±°C]	α (%/K)
55.0	717.6	702.2	732.9	2.1	0.6	3.3
60.0	608.0	594.0	622.0	2.3	0.7	3.2
65.0	519.0	506.2	531.8	2.5	0.8	3.1
70.0	444.8	433.2	456.5	2.6	0.9	3.1
75.0	382.1	371.5	392.6	2.8	0.9	3.0
80.0	329.3	319.7	338.9	2.9	1.0	2.9
85.0	285.4	276.7	294.1	3.1	1.1	2.8
90.0	248.3	240.4	256.2	3.2	1.2	2.8
95.0	217.1	209.9	224.3	3.3	1.2	2.7
100.0	190.6	184.0	197.1	3.4	1.3	2.6
105.0	167.2	161.3	173.2	3.6	1.4	2.6
110.0	147.2	141.8	152.7	3.7	1.5	2.5
115.0	130.0	125.0	134.9	3.8	1.6	2.4
120.0	115.0	110.5	119.6	3.9	1.6	2.4
125.0	102.3	98.14	106.4	4.0	1.7	2.3
130.0	91.17	87.38	94.96	4.2	1.8	2.3
135.0	81.32	77.85	84.79	4.3	1.9	2.2
140.0	72.69	69.51	75.87	4.4	2.0	2.2
145.0	65.20	62.28	68.12	4.5	2.1	2.1
150.0	58.61	55.93	61.29	4.6	2.2	2.1
155.0	52.91	50.43	55.38	4.7	2.3	2.0

B57885S0212H000						
R/T No.	1008					
T (°C)	B _{25/100} = 3560 K, R ₂₅ = 2100 Ω, T _R = 25 °C, ΔR _R /R _R = ± 3%					
	R _{nom} [Ω]	R _{min} [Ω]	R _{max} [Ω]	ΔR _R /R _R [±%]	ΔT[±°C]	α (%/K)
-55.0	111520	103230	119800	7.4	1.2	6.1
-50.0	82567	76735	88399	7.1	1.2	6.0
-45.0	61583	57449	65717	6.7	1.2	5.8
-40.0	46263	43312	49214	6.4	1.1	5.7
-35.0	34999	32879	37120	6.1	1.1	5.5
-30.0	26661	25128	28194	5.8	1.1	5.4
-25.0	20423	19308	21537	5.5	1.0	5.2
-20.0	15786	14969	16602	5.2	1.0	5.1
-15.0	12254	11654	12854	4.9	1.0	4.9
-10.0	9594	9149	10039	4.6	1.0	4.8
-5.0	7570	7238	7903	4.4	0.9	4.7
0.0	6020	5770	6269	4.1	0.9	4.5
5.0	4811	4622	4999	3.9	0.9	4.4
10.0	3872	3729	4014	3.7	0.9	4.3
15.0	3133	3025	3242	3.5	0.8	4.1
20.0	2552	2469	2635	3.3	0.8	4.0
25.0	2100	2037	2163	3.0	0.8	3.9
30.0	1742	1686	1799	3.2	0.9	3.8

B57885S0212H000						
R/T No.	1008					
T (°C)	B _{25/100} = 3560 K, R ₂₅ = 2100 Ω, T _R = 25 °C, ΔR _R /R _R = ± 3%					
	R _{nom} [Ω]	R _{min} [Ω]	R _{max} [Ω]	ΔR _R /R _R [±%]	ΔT[±°C]	α (%/K)
35.0	1441	1392	1491	3.4	0.9	3.7
40.0	1199	1156	1243	3.6	1.0	3.6
45.0	1008	970.0	1047	3.8	1.1	3.5
50.0	851.4	817.6	885.3	4.0	1.2	3.4
55.0	717.6	687.9	747.3	4.1	1.2	3.3
60.0	608.0	581.8	634.2	4.3	1.3	3.2
65.0	519.0	495.8	542.2	4.5	1.4	3.1
70.0	444.8	424.3	465.4	4.6	1.5	3.1
75.0	382.1	363.9	400.3	4.8	1.6	3.0
80.0	329.3	313.1	345.5	4.9	1.7	2.9
85.0	285.4	271.0	299.8	5.1	1.8	2.8
90.0	248.3	235.4	261.1	5.2	1.9	2.8
95.0	217.1	205.6	228.7	5.3	2.0	2.7
100.0	190.6	180.2	200.9	5.4	2.1	2.6
105.0	167.2	157.9	176.6	5.6	2.2	2.6
110.0	147.2	138.8	155.6	5.7	2.3	2.5
115.0	130.0	122.4	137.5	5.8	2.4	2.4
120.0	115.0	108.2	121.9	5.9	2.5	2.4
125.0	102.3	96.10	108.5	6.0	2.6	2.3
130.0	91.17	85.56	96.79	6.2	2.7	2.3
135.0	81.32	76.22	86.41	6.3	2.8	2.2
140.0	72.69	68.06	77.33	6.4	2.9	2.2
145.0	65.20	60.98	69.42	6.5	3.0	2.1
150.0	58.61	54.76	62.47	6.6	3.2	2.1
155.0	52.91	49.37	56.44	6.7	3.3	2.0

B57885S0212J000						
R/T No.	1008					
T (°C)	B _{25/100} = 3560 K, R ₂₅ = 2100 Ω, T _R = 25 °C, ΔR _R /R _R = ± 5%					
	R _{nom} [Ω]	R _{min} [Ω]	R _{max} [Ω]	ΔR _R /R _R [±%]	ΔT[±°C]	α (%/K)
-55.0	111520	101000	122030	9.4	1.5	6.1
-50.0	82567	75084	90050	9.1	1.5	6.0
-45.0	61583	56217	66949	8.7	1.5	5.8
-40.0	46263	42387	50139	8.4	1.5	5.7
-35.0	34999	32179	37820	8.1	1.5	5.5
-30.0	26661	24595	28728	7.8	1.4	5.4
-25.0	20423	18900	21945	7.5	1.4	5.2
-20.0	15786	14654	16918	7.2	1.4	5.1
-15.0	12254	11408	13100	6.9	1.4	4.9
-10.0	9594	8957	10231	6.6	1.4	4.8
-5.0	7570	7087	8054	6.4	1.4	4.7
0.0	6020	5650	6389	6.1	1.4	4.5
5.0	4811	4526	5095	5.9	1.3	4.4
10.0	3872	3652	4092	5.7	1.3	4.3

B57885S0212J000						
R/T No.	1008					
T (°C)	B _{25/100} = 3560 K, R ₂₅ = 2100 Ω, T _R = 25 °C, ΔR _R /R _R = ± 5%					
	R _{noml} [Ω]	R _{min} [Ω]	R _{max} [Ω]	ΔR _R /R _R [±%]	ΔT[±°C]	α (%/K)
15.0	3133	2962	3304	5.5	1.3	4.1
20.0	2552	2418	2687	5.3	1.3	4.0
25.0	2100	1995	2205	5.0	1.3	3.9
30.0	1742	1651	1834	5.2	1.4	3.8
35.0	1441	1363	1520	5.4	1.5	3.7
40.0	1199	1132	1267	5.6	1.6	3.6
45.0	1008	949.8	1067	5.8	1.7	3.5
50.0	851.4	800.6	902.3	6.0	1.8	3.4
55.0	717.6	673.5	761.6	6.1	1.9	3.3
60.0	608.0	569.7	646.3	6.3	2.0	3.2
65.0	519.0	485.5	552.5	6.5	2.1	3.1
70.0	444.8	415.4	474.3	6.6	2.2	3.1
75.0	382.1	356.2	407.9	6.8	2.3	3.0
80.0	329.3	306.5	352.0	6.9	2.4	2.9
85.0	285.4	265.3	305.5	7.1	2.5	2.8
90.0	248.3	230.4	266.1	7.2	2.6	2.8
95.0	217.1	201.2	233.0	7.3	2.7	2.7
100.0	190.6	176.4	204.8	7.4	2.8	2.6
105.0	167.2	154.6	179.9	7.6	3.0	2.6
110.0	147.2	135.9	158.5	7.7	3.1	2.5
115.0	130.0	119.8	140.1	7.8	3.2	2.4
120.0	115.0	105.9	124.2	7.9	3.3	2.4
125.0	102.3	94.05	110.5	8.0	3.4	2.3
130.0	91.17	83.73	98.61	8.2	3.6	2.3
135.0	81.32	74.59	88.04	8.3	3.7	2.2
140.0	72.69	66.61	78.78	8.4	3.8	2.2
145.0	65.20	59.67	70.73	8.5	4.0	2.1
150.0	58.61	53.58	63.64	8.6	4.1	2.1
155.0	52.91	48.32	57.50	8.7	4.3	2.0

B57885S0103F001						
R/T No.	2003					
T (°C)	B _{25/100} = 3980 K, R ₂₅ = 10000 Ω, T _R = 25 °C, ΔR _R /R _R = ± 1%					
	R _{noml} [Ω]	R _{min} [Ω]	R _{max} [Ω]	ΔR _R /R _R [±%]	ΔT[±°C]	α (%/K)
-55.0	975780	917770	1033800	5.9	0.8	7.4
-50.0	676500	639050	713960	5.5	0.8	7.2
-45.0	475380	450920	499840	5.1	0.7	6.9
-40.0	338310	322170	354460	4.8	0.7	6.7
-35.0	243590	232840	254340	4.4	0.7	6.5
-30.0	177530	170310	184760	4.1	0.7	6.2
-25.0	130670	125780	135550	3.7	0.6	6.0
-20.0	97228	93900	100560	3.4	0.6	5.8
-15.0	73006	70729	75282	3.1	0.6	5.6

B57885S0103F001						
R/T No.	2003					
T (°C)	B _{25/100} = 3980 K, R ₂₅ = 10000 Ω, T _R = 25 °C, ΔR _R /R _R = ± 1%					
	R _{nom} [Ω]	R _{min} [Ω]	R _{max} [Ω]	ΔR _R /R _R [±%]	ΔT[±°C]	α (%/K)
-10.0	55361	53797	56925	2.8	0.5	5.5
-5.0	42332	41256	43409	2.5	0.5	5.3
0.0	32660	31918	33402	2.3	0.4	5.1
5.0	25392	24881	25902	2.0	0.4	5.0
10.0	19902	19552	20251	1.8	0.4	4.8
15.0	15709	15472	15947	1.5	0.3	4.7
20.0	12492	12332	12652	1.3	0.3	4.5
25.0	10000	9900	10100	1.0	0.2	4.4
30.0	8057	7955	8160	1.3	0.3	4.3
35.0	6533	6436	6629	1.5	0.4	4.1
40.0	5329	5239	5419	1.7	0.4	4.0
45.0	4372	4289	4454	1.9	0.5	3.9
50.0	3606	3531	3682	2.1	0.5	3.8
55.0	2991	2923	3059	2.3	0.6	3.7
60.0	2493	2432	2554	2.5	0.7	3.6
65.0	2089	2034	2144	2.6	0.8	3.5
70.0	1758	1709	1807	2.8	0.8	3.4
75.0	1486	1442	1530	3.0	0.9	3.3
80.0	1262	1223	1302	3.1	1.0	3.2
85.0	1076	1041	1112	3.3	1.0	3.1
90.0	921.6	889.9	953.3	3.4	1.1	3.1
95.0	792.2	763.8	820.7	3.6	1.2	3.0
100.0	683.6	658.0	709.1	3.7	1.3	2.9
105.0	592.5	569.5	615.4	3.9	1.4	2.9
110.0	515.3	494.6	536.0	4.0	1.4	2.8
115.0	449.2	430.6	467.8	4.1	1.5	2.7
120.0	392.8	376.0	409.6	4.3	1.6	2.7
125.0	343.9	328.7	359.0	4.4	1.7	2.6
130.0	301.9	288.2	315.5	4.5	1.8	2.5
135.0	266.5	254.1	278.9	4.6	1.9	2.5
140.0	235.9	224.7	247.2	4.8	2.0	2.4
145.0	209.3	199.1	219.5	4.9	2.1	2.4
150.0	186.2	176.9	195.5	5.0	2.2	2.3
155.0	166.1	157.6	174.6	5.1	2.3	2.3

B57885S0103H001						
R/T No.	2003					
T (°C)	B _{25/100} = 3980 K, R ₂₅ = 10000 Ω, T _R = 25 °C, ΔR _R /R _R = ± 3%					
	R _{nom} [Ω]	R _{min} [Ω]	R _{max} [Ω]	ΔR _R /R _R [±%]	ΔT[±°C]	α (%/K)
-55.0	975780	898250	1053300	7.9	1.1	7.4
-50.0	676500	625520	727490	7.5	1.0	7.2
-45.0	475380	441410	509350	7.1	1.0	6.9
-40.0	338310	315400	361220	6.8	1.0	6.7



Temperature measurement and compensation

B57885S

Leaded NTC thermistors, lead spacing 5 mm

S885

B57885S0103H001						
R/T No.	2003					
T (°C)	B _{25/100} = 3980 K, R ₂₅ = 10000 Ω, T _R = 25 °C, ΔR _R /R _R = ± 3%					
	R _{nom} [Ω]	R _{min} [Ω]	R _{max} [Ω]	ΔR _R /R _R [±%]	ΔT[±°C]	α (%/K)
-35.0	243590	227970	259210	6.4	1.0	6.5
-30.0	177530	166760	188310	6.1	1.0	6.2
-25.0	130670	123170	138170	5.7	1.0	6.0
-20.0	97228	91956	102500	5.4	0.9	5.8
-15.0	73006	69269	76742	5.1	0.9	5.6
-10.0	55361	52689	58032	4.8	0.9	5.5
-5.0	42332	40409	44256	4.5	0.9	5.3
0.0	32660	31265	34055	4.3	0.8	5.1
5.0	25392	24374	26410	4.0	0.8	5.0
10.0	19902	19154	20649	3.8	0.8	4.8
15.0	15709	15157	16261	3.5	0.8	4.7
20.0	12492	12083	12901	3.3	0.7	4.5
25.0	10000	9700	10300	3.0	0.7	4.4
30.0	8057	7794	8321	3.3	0.8	4.3
35.0	6533	6305	6760	3.5	0.8	4.1
40.0	5329	5132	5526	3.7	0.9	4.0
45.0	4372	4202	4542	3.9	1.0	3.9
50.0	3606	3459	3754	4.1	1.1	3.8
55.0	2991	2863	3119	4.3	1.2	3.7
60.0	2493	2382	2604	4.5	1.2	3.6
65.0	2089	1992	2185	4.6	1.3	3.5
70.0	1758	1673	1842	4.8	1.4	3.4
75.0	1486	1412	1560	5.0	1.5	3.3
80.0	1262	1197	1327	5.1	1.6	3.2
85.0	1076	1019	1133	5.3	1.7	3.1
90.0	921.6	871.5	971.7	5.4	1.8	3.1
95.0	792.2	748.0	836.5	5.6	1.9	3.0
100.0	683.6	644.4	722.8	5.7	2.0	2.9
105.0	592.5	557.7	627.3	5.9	2.1	2.9
110.0	515.3	484.3	546.3	6.0	2.2	2.8
115.0	449.2	421.6	476.8	6.1	2.3	2.7
120.0	392.8	368.2	417.5	6.3	2.4	2.7
125.0	343.9	321.9	365.9	6.4	2.5	2.6
130.0	301.9	282.2	321.6	6.5	2.6	2.5
135.0	266.5	248.8	284.2	6.6	2.7	2.5
140.0	235.9	220.0	251.9	6.8	2.8	2.4
145.0	209.3	194.9	223.7	6.9	2.9	2.4
150.0	186.2	173.1	199.2	7.0	3.0	2.3
155.0	166.1	154.3	177.9	7.1	3.1	2.3

B57885S0103J001						
R/T No.	2003					
T (°C)	B _{25/100} = 3980 K, R ₂₅ = 10000 Ω, T _R = 25 °C, ΔR _R /R _R = ± 5%					
	R _{nom} [Ω]	R _{min} [Ω]	R _{max} [Ω]	ΔR _R /R _R [±%]	ΔT[±°C]	α (%/K)
-55.0	975780	878740	1072800	9.9	1.3	7.4
-50.0	676500	611990	741020	9.5	1.3	7.2
-45.0	475380	431900	518850	9.1	1.3	6.9
-40.0	338310	308640	367990	8.8	1.3	6.7
-35.0	243590	223100	264080	8.4	1.3	6.5
-30.0	177530	163210	191860	8.1	1.3	6.2
-25.0	130670	120550	140780	7.7	1.3	6.0
-20.0	97228	90011	104450	7.4	1.3	5.8
-15.0	73006	67809	78202	7.1	1.3	5.6
-10.0	55361	51582	59140	6.8	1.3	5.5
-5.0	42332	39562	45102	6.5	1.2	5.3
0.0	32660	30612	34708	6.3	1.2	5.1
5.0	25392	23866	26918	6.0	1.2	5.0
10.0	19902	18756	21047	5.8	1.2	4.8
15.0	15709	14843	16575	5.5	1.2	4.7
20.0	12492	11833	13151	5.3	1.2	4.5
25.0	10000	9500	10500	5.0	1.1	4.4
30.0	8057	7633	8482	5.3	1.2	4.3
35.0	6533	6174	6891	5.5	1.3	4.1
40.0	5329	5026	5632	5.7	1.4	4.0
45.0	4372	4114	4629	5.9	1.5	3.9
50.0	3606	3387	3826	6.1	1.6	3.8
55.0	2991	2803	3178	6.3	1.7	3.7
60.0	2493	2332	2654	6.5	1.8	3.6
65.0	2089	1950	2227	6.6	1.9	3.5
70.0	1758	1638	1877	6.8	2.0	3.4
75.0	1486	1383	1590	7.0	2.1	3.3
80.0	1262	1172	1352	7.1	2.2	3.2
85.0	1076	997.9	1155	7.3	2.3	3.1
90.0	921.6	853.0	990.1	7.4	2.4	3.1
95.0	792.2	732.1	852.4	7.6	2.5	3.0
100.0	683.6	630.7	736.4	7.7	2.6	2.9
105.0	592.5	545.8	639.1	7.9	2.8	2.9
110.0	515.3	474.0	556.6	8.0	2.9	2.8
115.0	449.2	412.6	485.8	8.1	3.0	2.7
120.0	392.8	360.3	425.3	8.3	3.1	2.7
125.0	343.9	315.0	372.8	8.4	3.2	2.6
130.0	301.9	276.1	327.6	8.5	3.4	2.5
135.0	266.5	243.5	289.5	8.6	3.5	2.5
140.0	235.9	215.3	256.6	8.8	3.6	2.4
145.0	209.3	190.7	227.9	8.9	3.8	2.4
150.0	186.2	169.4	202.9	9.0	3.9	2.3
155.0	166.1	151.0	181.2	9.1	4.0	2.3

B57885S0103F002						
R/T No.	2908					
T (°C)	B _{25/100} = 3460 K, R ₂₅ = 10000 Ω, T _R = 25 °C, ΔR _R /R _R = ± 1%					
	R _{nom} [Ω]	R _{min} [Ω]	R _{max} [Ω]	ΔR _R /R _R [±%]	ΔT[±°C]	α (%/K)
-55.0	453130	429090	477170	5.3	0.9	6.0
-50.0	337290	320600	353990	5.0	0.9	5.8
-45.0	253330	241650	265010	4.6	0.8	5.6
-40.0	191910	183680	200130	4.3	0.8	5.5
-35.0	146590	140770	152420	4.0	0.7	5.3
-30.0	112880	108730	117030	3.7	0.7	5.1
-25.0	87588	84620	90556	3.4	0.7	5.0
-20.0	68471	66339	70602	3.1	0.6	4.9
-15.0	53910	52375	55446	2.8	0.6	4.7
-10.0	42739	41631	43848	2.6	0.6	4.6
-5.0	34109	33308	34910	2.3	0.5	4.4
0.0	27396	26817	27974	2.1	0.5	4.3
5.0	22140	21722	22557	1.9	0.4	4.2
10.0	17999	17699	18298	1.7	0.4	4.1
15.0	14716	14502	14930	1.5	0.4	4.0
20.0	12099	11948	12250	1.2	0.3	3.9
25.0	10000	9900	10100	1.0	0.3	3.8
30.0	8308	8205	8411	1.2	0.3	3.7
35.0	6936	6837	7035	1.4	0.4	3.6
40.0	5819	5725	5912	1.6	0.5	3.5
45.0	4904	4816	4991	1.8	0.5	3.4
50.0	4151	4070	4232	1.9	0.6	3.3
55.0	3529	3454	3603	2.1	0.7	3.2
60.0	3012	2944	3081	2.3	0.7	3.1
65.0	2582	2519	2644	2.4	0.8	3.0
70.0	2221	2164	2278	2.6	0.9	3.0
75.0	1918	1866	1970	2.7	0.9	2.9
80.0	1663	1615	1710	2.9	1.0	2.8
85.0	1446	1403	1489	3.0	1.1	2.8
90.0	1262	1222	1301	3.1	1.2	2.7
95.0	1105	1069	1141	3.3	1.2	2.6
100.0	970.2	937.4	1003	3.4	1.3	2.6
105.0	854.6	824.7	884.6	3.5	1.4	2.5
110.0	755.1	727.7	782.4	3.6	1.5	2.4
115.0	669.0	644.0	694.0	3.7	1.6	2.4
120.0	594.4	571.5	617.3	3.9	1.6	2.3
125.0	529.5	508.5	550.5	4.0	1.7	2.3
130.0	472.9	453.6	492.2	4.1	1.8	2.2
135.0	423.4	405.7	441.1	4.2	1.9	2.2
140.0	380.0	363.8	396.3	4.3	2.0	2.1
145.0	341.9	326.9	356.9	4.4	2.1	2.1
150.0	308.3	294.5	322.1	4.5	2.2	2.0
155.0	278.6	265.8	291.3	4.6	2.3	2.0

B57885S0103H002						
R/T No.	2908					
T (°C)	B _{25/100} = 3460 K, R ₂₅ = 10000 Ω, T _R = 25 °C, ΔR _R /R _R = ± 3%					
	R _{nom} [Ω]	R _{min} [Ω]	R _{max} [Ω]	ΔR _R /R _R [±%]	ΔT[±°C]	α (%/K)
-55.0	453130	420030	486230	7.3	1.2	6.0
-50.0	337290	313850	360740	7.0	1.2	5.8
-45.0	253330	236580	270070	6.6	1.2	5.6
-40.0	191910	179850	203970	6.3	1.1	5.5
-35.0	146590	137840	155350	6.0	1.1	5.3
-30.0	112880	106470	119280	5.7	1.1	5.1
-25.0	87588	82868	92307	5.4	1.1	5.0
-20.0	68471	64970	71971	5.1	1.1	4.9
-15.0	53910	51296	56524	4.8	1.0	4.7
-10.0	42739	40776	44702	4.6	1.0	4.6
-5.0	34109	32626	35592	4.3	1.0	4.4
0.0	27396	26269	28522	4.1	1.0	4.3
5.0	22140	21280	23000	3.9	0.9	4.2
10.0	17999	17339	18658	3.7	0.9	4.1
15.0	14716	14208	15224	3.5	0.9	4.0
20.0	12099	11706	12492	3.2	0.8	3.9
25.0	10000	9700	10300	3.0	0.8	3.8
30.0	8308	8038	8577	3.2	0.9	3.7
35.0	6936	6698	7174	3.4	1.0	3.6
40.0	5819	5609	6028	3.6	1.0	3.5
45.0	4904	4718	5089	3.8	1.1	3.4
50.0	4151	3987	4315	3.9	1.2	3.3
55.0	3529	3384	3674	4.1	1.3	3.2
60.0	3012	2884	3141	4.3	1.4	3.1
65.0	2582	2468	2696	4.4	1.5	3.0
70.0	2221	2120	2323	4.6	1.5	3.0
75.0	1918	1828	2009	4.7	1.6	2.9
80.0	1663	1582	1743	4.9	1.7	2.8
85.0	1446	1374	1518	5.0	1.8	2.8
90.0	1262	1197	1327	5.1	1.9	2.7
95.0	1105	1047	1163	5.3	2.0	2.6
100.0	970.2	918.0	1022	5.4	2.1	2.6
105.0	854.6	807.6	901.7	5.5	2.2	2.5
110.0	755.1	712.6	797.5	5.6	2.3	2.4
115.0	669.0	630.6	707.4	5.7	2.4	2.4
120.0	594.4	559.6	629.2	5.9	2.5	2.3
125.0	529.5	497.9	561.1	6.0	2.6	2.3
130.0	472.9	444.2	501.6	6.1	2.7	2.2
135.0	423.4	397.3	449.6	6.2	2.8	2.2
140.0	380.0	356.2	403.9	6.3	2.9	2.1
145.0	341.9	320.1	363.7	6.4	3.0	2.1
150.0	308.3	288.3	328.3	6.5	3.2	2.0
155.0	278.6	260.3	296.9	6.6	3.3	2.0

B57885S0103J002						
R/T No.	2908					
T (°C)	B _{25/100} = 3460 K, R ₂₅ = 10000 Ω, T _R = 25 °C, ΔR _R /R _R = ± 5%					
	R _{nom} [Ω]	R _{min} [Ω]	R _{max} [Ω]	ΔR _R /R _R [±%]	ΔT[±°C]	α (%/K)
-55.0	453130	410960	495300	9.3	1.6	6.0
-50.0	337290	307100	367480	9.0	1.5	5.8
-45.0	253330	231510	275140	8.6	1.5	5.6
-40.0	191910	176010	207810	8.3	1.5	5.5
-35.0	146590	134900	158280	8.0	1.5	5.3
-30.0	112880	104210	121540	7.7	1.5	5.1
-25.0	87588	81117	94059	7.4	1.5	5.0
-20.0	68471	63600	73341	7.1	1.5	4.9
-15.0	53910	50218	57602	6.8	1.5	4.7
-10.0	42739	39921	45557	6.6	1.4	4.6
-5.0	34109	31943	36274	6.3	1.4	4.4
0.0	27396	25721	29070	6.1	1.4	4.3
5.0	22140	20837	23442	5.9	1.4	4.2
10.0	17999	16979	19018	5.7	1.4	4.1
15.0	14716	13914	15519	5.5	1.4	4.0
20.0	12099	11464	12734	5.2	1.4	3.9
25.0	10000	9500	10500	5.0	1.3	3.8
30.0	8308	7872	8743	5.2	1.4	3.7
35.0	6936	6560	7312	5.4	1.5	3.6
40.0	5819	5492	6145	5.6	1.6	3.5
45.0	4904	4620	5187	5.8	1.7	3.4
50.0	4151	3904	4398	5.9	1.8	3.3
55.0	3529	3313	3744	6.1	1.9	3.2
60.0	3012	2824	3201	6.3	2.0	3.1
65.0	2582	2416	2748	6.4	2.1	3.0
70.0	2221	2075	2367	6.6	2.2	3.0
75.0	1918	1789	2047	6.7	2.3	2.9
80.0	1663	1549	1777	6.9	2.4	2.8
85.0	1446	1345	1547	7.0	2.5	2.8
90.0	1262	1172	1352	7.1	2.6	2.7
95.0	1105	1025	1185	7.3	2.8	2.6
100.0	970.2	898.5	1042	7.4	2.9	2.6
105.0	854.6	790.5	918.8	7.5	3.0	2.5
110.0	755.1	697.5	812.6	7.6	3.1	2.4
115.0	669.0	617.2	720.8	7.7	3.2	2.4
120.0	594.4	547.7	641.1	7.9	3.4	2.3
125.0	529.5	487.3	571.6	8.0	3.5	2.3
130.0	472.9	434.7	511.1	8.1	3.6	2.2
135.0	423.4	388.8	458.0	8.2	3.7	2.2
140.0	380.0	348.6	411.5	8.3	3.9	2.1
145.0	341.9	313.2	370.5	8.4	4.0	2.1
150.0	308.3	282.1	334.4	8.5	4.1	2.0
155.0	278.6	254.7	302.5	8.6	4.3	2.0

B57885S0103F003						
R/T No.	2001					
T (°C)	B _{25/100} = 3920 K, R ₂₅ = 10000 Ω, T _R = 25 °C, ΔR _R /R _R = ± 1%					
	R _{nom} [Ω]	R _{min} [Ω]	R _{max} [Ω]	ΔR _R /R _R [±%]	ΔT[±°C]	α (%/K)
-55.0	877620	826090	929150	5.9	0.8	7.0
-50.0	619220	585350	653080	5.5	0.8	6.8
-45.0	441680	419220	464130	5.1	0.8	6.7
-40.0	318330	303320	333340	4.7	0.7	6.5
-35.0	231730	221620	241840	4.4	0.7	6.3
-30.0	170300	163450	177160	4.0	0.7	6.1
-25.0	126210	121540	130880	3.7	0.6	5.9
-20.0	94515	91314	97717	3.4	0.6	5.7
-15.0	71273	69073	73474	3.1	0.6	5.5
-10.0	54270	52751	55789	2.8	0.5	5.4
-5.0	41522	40475	42569	2.5	0.5	5.2
0.0	32063	31340	32785	2.3	0.4	5.0
5.0	25019	24520	25518	2.0	0.4	4.9
10.0	19679	19336	20023	1.7	0.4	4.7
15.0	15623	15387	15858	1.5	0.3	4.6
20.0	12488	12329	12648	1.3	0.3	4.5
25.0	10000	9900	10100	1.0	0.2	4.3
30.0	8110	8008	8213	1.3	0.3	4.2
35.0	6593	6496	6690	1.5	0.4	4.1
40.0	5392	5302	5483	1.7	0.4	4.0
45.0	4434	4351	4518	1.9	0.5	3.8
50.0	3667	3592	3743	2.1	0.6	3.7
55.0	3051	2983	3120	2.3	0.6	3.6
60.0	2551	2489	2613	2.4	0.7	3.5
65.0	2146	2090	2202	2.6	0.8	3.4
70.0	1813	1763	1863	2.8	0.8	3.4
75.0	1536	1491	1581	2.9	0.9	3.3
80.0	1306	1266	1347	3.1	1.0	3.2
85.0	1116	1079	1152	3.3	1.0	3.1
90.0	956.1	923.5	988.6	3.4	1.1	3.0
95.0	823.5	794.2	852.7	3.5	1.2	3.0
100.0	711.8	685.5	738.1	3.7	1.3	2.9
105.0	617.8	594.1	641.5	3.8	1.4	2.8
110.0	538.0	516.7	559.3	4.0	1.4	2.7
115.0	469.7	450.4	488.9	4.1	1.5	2.7
120.0	411.3	393.9	428.7	4.2	1.6	2.6
125.0	361.4	345.7	377.1	4.4	1.7	2.6
130.0	318.5	304.2	332.7	4.5	1.8	2.5
135.0	281.5	268.6	294.5	4.6	1.9	2.5
140.0	249.5	237.8	261.3	4.7	2.0	2.4
145.0	221.6	210.9	232.3	4.8	2.1	2.3
150.0	197.2	187.5	207.0	4.9	2.1	2.3
155.0	176.1	167.2	184.9	5.0	2.2	2.2

B57885S0103H003						
R/T No.	2001					
T (°C)	B _{25/100} = 3920 K, R ₂₅ = 10000 Ω, T _R = 25 °C, ΔR _R /R _R = ± 3%					
	R _{nom} [Ω]	R _{min} [Ω]	R _{max} [Ω]	ΔR _R /R _R [±%]	ΔT[±°C]	α (%/K)
-55.0	877620	808540	946710	7.9	1.1	7.0
-50.0	619220	572970	665470	7.5	1.1	6.8
-45.0	441680	410390	472970	7.1	1.1	6.7
-40.0	318330	296960	339710	6.7	1.0	6.5
-35.0	231730	216990	246470	6.4	1.0	6.3
-30.0	170300	160040	180560	6.0	1.0	6.1
-25.0	126210	119010	133400	5.7	1.0	5.9
-20.0	94515	89424	99607	5.4	0.9	5.7
-15.0	71273	67648	74899	5.1	0.9	5.5
-10.0	54270	51666	56874	4.8	0.9	5.4
-5.0	41522	39645	43399	4.5	0.9	5.2
0.0	32063	30699	33426	4.3	0.8	5.0
5.0	25019	24019	26019	4.0	0.8	4.9
10.0	19679	18942	20417	3.7	0.8	4.7
15.0	15623	15075	16170	3.5	0.8	4.6
20.0	12488	12080	12897	3.3	0.7	4.5
25.0	10000	9700	10300	3.0	0.7	4.3
30.0	8110	7846	8375	3.3	0.8	4.2
35.0	6593	6364	6822	3.5	0.9	4.1
40.0	5392	5194	5591	3.7	0.9	4.0
45.0	4434	4263	4606	3.9	1.0	3.8
50.0	3667	3518	3817	4.1	1.1	3.7
55.0	3051	2922	3181	4.3	1.2	3.6
60.0	2551	2438	2664	4.4	1.3	3.5
65.0	2146	2047	2244	4.6	1.3	3.4
70.0	1813	1727	1900	4.8	1.4	3.4
75.0	1536	1460	1612	4.9	1.5	3.3
80.0	1306	1240	1373	5.1	1.6	3.2
85.0	1116	1057	1174	5.3	1.7	3.1
90.0	956.1	904.4	1008	5.4	1.8	3.0
95.0	823.5	777.8	869.2	5.5	1.9	3.0
100.0	711.8	671.3	752.3	5.7	2.0	2.9
105.0	617.8	581.8	653.8	5.8	2.1	2.8
110.0	538.0	505.9	570.1	6.0	2.2	2.7
115.0	469.7	441.1	498.3	6.1	2.3	2.7
120.0	411.3	385.7	436.9	6.2	2.4	2.6
125.0	361.4	338.5	384.4	6.4	2.5	2.6
130.0	318.5	297.9	339.1	6.5	2.6	2.5
135.0	281.5	263.0	300.1	6.6	2.7	2.5
140.0	249.5	232.8	266.3	6.7	2.8	2.4
145.0	221.6	206.5	236.7	6.8	2.9	2.3
150.0	197.2	183.5	210.9	6.9	3.0	2.3
155.0	176.1	163.7	188.5	7.0	3.1	2.2

B57885S0103J003						
R/T No.	2001					
T (°C)	B _{25/100} = 3920 K, R ₂₅ = 10000 Ω, T _R = 25 °C, ΔR _R /R _R = ± 5%					
	R _{nom} [Ω]	R _{min} [Ω]	R _{max} [Ω]	ΔR _R /R _R [±%]	ΔT[±°C]	α (%/K)
-55.0	877620	790990	964260	9.9	1.4	7.0
-50.0	619220	560580	677850	9.5	1.4	6.8
-45.0	441680	401560	481800	9.1	1.4	6.7
-40.0	318330	290590	346080	8.7	1.3	6.5
-35.0	231730	212350	251110	8.4	1.3	6.3
-30.0	170300	156640	183970	8.0	1.3	6.1
-25.0	126210	116490	135920	7.7	1.3	5.9
-20.0	94515	87533	101500	7.4	1.3	5.7
-15.0	71273	66222	76325	7.1	1.3	5.5
-10.0	54270	50580	57960	6.8	1.3	5.4
-5.0	41522	38815	44230	6.5	1.3	5.2
0.0	32063	30058	34068	6.3	1.2	5.0
5.0	25019	23519	26519	6.0	1.2	4.9
10.0	19679	18549	20810	5.7	1.2	4.7
15.0	15623	14762	16483	5.5	1.2	4.6
20.0	12488	11830	13147	5.3	1.2	4.5
25.0	10000	9500	10500	5.0	1.2	4.3
30.0	8110	7683	8538	5.3	1.3	4.2
35.0	6593	6232	6954	5.5	1.3	4.1
40.0	5392	5086	5699	5.7	1.4	4.0
45.0	4434	4174	4695	5.9	1.5	3.8
50.0	3667	3445	3890	6.1	1.6	3.7
55.0	3051	2861	3242	6.3	1.7	3.6
60.0	2551	2387	2715	6.4	1.8	3.5
65.0	2146	2004	2287	6.6	1.9	3.4
70.0	1813	1690	1936	6.8	2.0	3.4
75.0	1536	1429	1643	6.9	2.1	3.3
80.0	1306	1214	1399	7.1	2.2	3.2
85.0	1116	1035	1196	7.3	2.3	3.1
90.0	956.1	885.3	1027	7.4	2.4	3.0
95.0	823.5	761.3	885.6	7.5	2.6	3.0
100.0	711.8	657.0	766.6	7.7	2.7	2.9
105.0	617.8	569.4	666.2	7.8	2.8	2.8
110.0	538.0	495.1	580.9	8.0	2.9	2.7
115.0	469.7	431.7	507.7	8.1	3.0	2.7
120.0	411.3	377.5	445.2	8.2	3.1	2.6
125.0	361.4	331.2	391.6	8.4	3.3	2.6
130.0	318.5	291.5	345.5	8.5	3.4	2.5
135.0	281.5	257.3	305.7	8.6	3.5	2.5
140.0	249.5	227.8	271.3	8.7	3.6	2.4
145.0	221.6	202.0	241.1	8.8	3.8	2.3
150.0	197.2	179.6	214.8	8.9	3.9	2.3
155.0	176.1	160.1	192.0	9.0	4.0	2.2

B57885S0123F000						
R/T No.	2901					
T (°C)	B _{25/100} = 3760 K, R ₂₅ = 12000 Ω, T _R = 25 °C, ΔR _R /R _R = ± 1%					
	R _{nom} [Ω]	R _{min} [Ω]	R _{max} [Ω]	ΔR _R /R _R [±%]	ΔT[±°C]	α (%/K)
-55.0	767630	724060	811190	5.7	0.9	6.4
-50.0	554140	524840	583450	5.3	0.8	6.3
-45.0	404850	384940	424770	4.9	0.8	6.1
-40.0	299120	285460	312780	4.6	0.8	6.0
-35.0	223330	213890	232770	4.2	0.7	5.8
-30.0	168400	161830	174970	3.9	0.7	5.6
-25.0	128150	123550	132750	3.6	0.7	5.5
-20.0	98376	95138	101610	3.3	0.6	5.3
-15.0	75748	73472	78023	3.0	0.6	5.1
-10.0	58816	57212	60421	2.7	0.5	5.0
-5.0	45852	44724	46980	2.5	0.5	4.9
0.0	36033	35238	36827	2.2	0.5	4.7
5.0	28562	28003	29121	2.0	0.4	4.6
10.0	22799	22408	23191	1.7	0.4	4.5
15.0	18308	18036	18580	1.5	0.3	4.3
20.0	14796	14609	14983	1.3	0.3	4.2
25.0	12000	11880	12120	1.0	0.2	4.1
30.0	9801	9678	9925	1.3	0.3	4.0
35.0	8060	7942	8178	1.5	0.4	3.9
40.0	6663	6553	6773	1.7	0.4	3.8
45.0	5531	5430	5633	1.8	0.5	3.7
50.0	4615	4522	4709	2.0	0.6	3.6
55.0	3862	3777	3947	2.2	0.6	3.5
60.0	3248	3171	3325	2.4	0.7	3.4
65.0	2749	2679	2819	2.5	0.8	3.3
70.0	2336	2273	2399	2.7	0.8	3.2
75.0	1993	1936	2050	2.9	0.9	3.2
80.0	1707	1655	1758	3.0	1.0	3.1
85.0	1466	1420	1512	3.2	1.1	3.0
90.0	1264	1222	1306	3.3	1.1	2.9
95.0	1095	1057	1133	3.4	1.2	2.9
100.0	951.4	917.3	985.5	3.6	1.3	2.8
105.0	828.7	797.9	859.6	3.7	1.4	2.7
110.0	724.1	696.2	751.9	3.8	1.4	2.7
115.0	634.6	609.4	659.8	4.0	1.5	2.6
120.0	557.8	534.9	580.6	4.1	1.6	2.6
125.0	491.8	471.1	512.6	4.2	1.7	2.5
130.0	434.8	416.0	453.6	4.3	1.8	2.4
135.0	385.2	368.1	402.4	4.4	1.9	2.4
140.0	342.1	326.5	357.7	4.6	1.9	2.3
145.0	304.5	290.3	318.7	4.7	2.0	2.3
150.0	271.6	258.6	284.6	4.8	2.1	2.3
155.0	242.8	230.9	254.6	4.9	2.2	2.2

B57885S0123H000						
R/T No.	2901					
T (°C)	B _{25/100} = 3760 K, R ₂₅ = 12000 Ω, T _R = 25 °C, ΔR _R /R _R = ± 3%					
	R _{nom} [Ω]	R _{min} [Ω]	R _{max} [Ω]	ΔR _R /R _R [±%]	ΔT[±°C]	α (%/K)
-55.0	767630	708710	826540	7.7	1.2	6.4
-50.0	554140	513760	594530	7.3	1.2	6.3
-45.0	404850	376840	432870	6.9	1.1	6.1
-40.0	299120	279480	318760	6.6	1.1	6.0
-35.0	223330	209420	237240	6.2	1.1	5.8
-30.0	168400	158460	178340	5.9	1.1	5.6
-25.0	128150	120990	135320	5.6	1.0	5.5
-20.0	98376	93170	103580	5.3	1.0	5.3
-15.0	75748	71957	79538	5.0	1.0	5.1
-10.0	58816	56036	61597	4.7	0.9	5.0
-5.0	45852	43807	47897	4.5	0.9	4.9
0.0	36033	34518	37548	4.2	0.9	4.7
5.0	28562	27432	29692	4.0	0.9	4.6
10.0	22799	21952	23647	3.7	0.8	4.5
15.0	18308	17670	18947	3.5	0.8	4.3
20.0	14796	14313	15279	3.3	0.8	4.2
25.0	12000	11640	12360	3.0	0.7	4.1
30.0	9801	9482	10121	3.3	0.8	4.0
35.0	8060	7781	8339	3.5	0.9	3.9
40.0	6663	6420	6907	3.7	1.0	3.8
45.0	5531	5319	5744	3.8	1.0	3.7
50.0	4615	4429	4801	4.0	1.1	3.6
55.0	3862	3700	4024	4.2	1.2	3.5
60.0	3248	3106	3390	4.4	1.3	3.4
65.0	2749	2624	2874	4.5	1.4	3.3
70.0	2336	2226	2446	4.7	1.5	3.2
75.0	1993	1896	2090	4.9	1.5	3.2
80.0	1707	1621	1792	5.0	1.6	3.1
85.0	1466	1390	1542	5.2	1.7	3.0
90.0	1264	1197	1331	5.3	1.8	2.9
95.0	1095	1035	1154	5.4	1.9	2.9
100.0	951.4	898.3	1005	5.6	2.0	2.8
105.0	828.7	781.4	876.1	5.7	2.1	2.7
110.0	724.1	681.7	766.4	5.8	2.2	2.7
115.0	634.6	596.7	672.5	6.0	2.3	2.6
120.0	557.8	523.8	591.8	6.1	2.4	2.6
125.0	491.8	461.2	522.4	6.2	2.5	2.5
130.0	434.8	407.3	462.3	6.3	2.6	2.4
135.0	385.2	360.4	410.1	6.4	2.7	2.4
140.0	342.1	319.7	364.6	6.6	2.8	2.3
145.0	304.5	284.2	324.8	6.7	2.9	2.3
150.0	271.6	253.2	290.0	6.8	3.0	2.3
155.0	242.8	226.1	259.5	6.9	3.1	2.2

B57885S0123J000						
R/T No.	2901					
T (°C)	B _{25/100} = 3760 K, R ₂₅ = 12000 Ω, T _R = 25 °C, ΔR _R /R _R = ± 5%					
	R _{nom} [Ω]	R _{min} [Ω]	R _{max} [Ω]	ΔR _R /R _R [±%]	ΔT[±°C]	α (%/K)
-55.0	767630	693360	841890	9.7	1.5	6.4
-50.0	554140	502670	605620	9.3	1.5	6.3
-45.0	404850	368740	440960	8.9	1.5	6.1
-40.0	299120	273500	324740	8.6	1.4	6.0
-35.0	223330	204960	241710	8.2	1.4	5.8
-30.0	168400	155090	181710	7.9	1.4	5.6
-25.0	128150	118420	137880	7.6	1.4	5.5
-20.0	98376	91203	105550	7.3	1.4	5.3
-15.0	75748	70442	81053	7.0	1.4	5.1
-10.0	58816	54860	62773	6.7	1.3	5.0
-5.0	45852	42890	48815	6.5	1.3	4.9
0.0	36033	33797	38268	6.2	1.3	4.7
5.0	28562	26860	30263	6.0	1.3	4.6
10.0	22799	21496	24103	5.7	1.3	4.5
15.0	18308	17303	19313	5.5	1.3	4.3
20.0	14796	14017	15575	5.3	1.3	4.2
25.0	12000	11400	12600	5.0	1.2	4.1
30.0	9801	9286	10317	5.3	1.3	4.0
35.0	8060	7620	8500	5.5	1.4	3.9
40.0	6663	6287	7040	5.7	1.5	3.8
45.0	5531	5208	5855	5.8	1.6	3.7
50.0	4615	4337	4893	6.0	1.7	3.6
55.0	3862	3622	4102	6.2	1.8	3.5
60.0	3248	3041	3455	6.4	1.9	3.4
65.0	2749	2569	2929	6.5	2.0	3.3
70.0	2336	2180	2493	6.7	2.1	3.2
75.0	1993	1856	2130	6.9	2.2	3.2
80.0	1707	1587	1826	7.0	2.3	3.1
85.0	1466	1361	1571	7.2	2.4	3.0
90.0	1264	1172	1356	7.3	2.5	2.9
95.0	1095	1013	1176	7.4	2.6	2.9
100.0	951.4	879.2	1024	7.6	2.7	2.8
105.0	828.7	764.8	892.7	7.7	2.8	2.7
110.0	724.1	667.3	780.9	7.8	2.9	2.7
115.0	634.6	584.0	685.2	8.0	3.0	2.6
120.0	557.8	512.6	603.0	8.1	3.2	2.6
125.0	491.8	451.4	532.2	8.2	3.3	2.5
130.0	434.8	398.6	471.0	8.3	3.4	2.4
135.0	385.2	352.7	417.8	8.4	3.5	2.4
140.0	342.1	312.8	371.4	8.6	3.6	2.3
145.0	304.5	278.1	330.9	8.7	3.8	2.3
150.0	271.6	247.8	295.4	8.8	3.9	2.3
155.0	242.8	221.2	264.3	8.9	4.0	2.2

B57885S0303F000						
R/T No.	8018					
T (°C)	B _{25/100} = 3964 K, R ₂₅ = 30000 Ω, T _R = 25 °C, ΔR _R /R _R = ± 1%					
	R _{nom} [Ω]	R _{min} [Ω]	R _{max} [Ω]	ΔR _R /R _R [±%]	ΔT[±°C]	α (%/K)
-55.0	2472200	2325700	2618700	5.9	0.8	7.0
-50.0	1750300	1653700	1846900	5.5	0.8	6.8
-45.0	1253200	1189000	1317500	5.1	0.8	6.6
-40.0	907060	863910	950200	4.8	0.7	6.4
-35.0	663280	634100	692460	4.4	0.7	6.2
-30.0	489810	469940	509680	4.1	0.7	6.0
-25.0	365130	351510	378740	3.7	0.6	5.8
-20.0	274640	265270	284020	3.4	0.6	5.6
-15.0	208370	201890	214850	3.1	0.6	5.4
-10.0	159410	154910	163900	2.8	0.5	5.3
-5.0	122920	119800	126030	2.5	0.5	5.1
0.0	95501	93336	97666	2.3	0.5	5.0
5.0	74745	73245	76244	2.0	0.4	4.8
10.0	58911	57877	59944	1.8	0.4	4.7
15.0	46745	46038	47451	1.5	0.3	4.6
20.0	37332	36855	37808	1.3	0.3	4.4
25.0	30000	29700	30300	1.0	0.2	4.3
30.0	24253	23945	24561	1.3	0.3	4.2
35.0	19720	19428	20012	1.5	0.4	4.1
40.0	16123	15851	16395	1.7	0.4	4.0
45.0	13252	13002	13502	1.9	0.5	3.9
50.0	10949	10721	11177	2.1	0.6	3.8
55.0	9091	8885	9297	2.3	0.6	3.7
60.0	7584	7399	7770	2.4	0.7	3.6
65.0	6356	6189	6523	2.6	0.8	3.5
70.0	5351	5201	5500	2.8	0.8	3.4
75.0	4524	4390	4657	3.0	0.9	3.3
80.0	3840	3720	3960	3.1	1.0	3.2
85.0	3273	3166	3380	3.3	1.0	3.2
90.0	2800	2704	2896	3.4	1.1	3.1
95.0	2405	2319	2491	3.6	1.2	3.0
100.0	2073	1995	2150	3.7	1.3	2.9
105.0	1792	1723	1862	3.9	1.3	2.9
110.0	1555	1493	1618	4.0	1.4	2.8
115.0	1354	1298	1410	4.1	1.5	2.7
120.0	1182	1132	1233	4.3	1.6	2.7
125.0	1036	990.3	1081	4.4	1.7	2.6
130.0	910.0	868.9	951.0	4.5	1.8	2.6
135.0	801.7	764.6	838.9	4.6	1.8	2.5
140.0	708.3	674.6	741.9	4.8	1.9	2.5
145.0	627.4	596.9	658.0	4.9	2.0	2.4
150.0	557.2	529.5	585.0	5.0	2.1	2.3
155.0	496.1	470.9	521.4	5.1	2.2	2.3

B57885S0303H000						
R/T No.	8018					
T (°C)	B _{25/100} = 3964 K, R ₂₅ = 30000 Ω, T _R = 25 °C, ΔR _R /R _R = ± 3%					
	R _{nom} [Ω]	R _{min} [Ω]	R _{max} [Ω]	ΔR _R /R _R [±%]	ΔT[±°C]	α (%/K)
-55.0	2472200	2276300	2668200	7.9	1.1	7.0
-50.0	1750300	1618700	1881900	7.5	1.1	6.8
-45.0	1253200	1163900	1342600	7.1	1.1	6.6
-40.0	907060	845770	968340	6.8	1.1	6.4
-35.0	663280	620830	705730	6.4	1.0	6.2
-30.0	489810	460140	519480	6.1	1.0	6.0
-25.0	365130	344210	386040	5.7	1.0	5.8
-20.0	274640	259780	289510	5.4	1.0	5.6
-15.0	208370	197730	219020	5.1	0.9	5.4
-10.0	159410	151720	167090	4.8	0.9	5.3
-5.0	122920	117340	128490	4.5	0.9	5.1
0.0	95501	91426	99576	4.3	0.9	5.0
5.0	74745	71750	77739	4.0	0.8	4.8
10.0	58911	56699	61122	3.8	0.8	4.7
15.0	46745	45103	48386	3.5	0.8	4.6
20.0	37332	36108	38555	3.3	0.7	4.4
25.0	30000	29100	30900	3.0	0.7	4.3
30.0	24253	23460	25046	3.3	0.8	4.2
35.0	19720	19033	20406	3.5	0.9	4.1
40.0	16123	15528	16717	3.7	0.9	4.0
45.0	13252	12737	13767	3.9	1.0	3.9
50.0	10949	10503	11396	4.1	1.1	3.8
55.0	9091	8703	9479	4.3	1.2	3.7
60.0	7584	7247	7921	4.4	1.2	3.6
65.0	6356	6062	6650	4.6	1.3	3.5
70.0	5351	5094	5607	4.8	1.4	3.4
75.0	4524	4299	4748	5.0	1.5	3.3
80.0	3840	3643	4037	5.1	1.6	3.2
85.0	3273	3100	3446	5.3	1.7	3.2
90.0	2800	2648	2952	5.4	1.8	3.1
95.0	2405	2271	2539	5.6	1.9	3.0
100.0	2073	1954	2191	5.7	1.9	2.9
105.0	1792	1687	1897	5.9	2.0	2.9
110.0	1555	1462	1649	6.0	2.1	2.8
115.0	1354	1271	1437	6.1	2.2	2.7
120.0	1182	1108	1257	6.3	2.3	2.7
125.0	1036	969.6	1102	6.4	2.4	2.6
130.0	910.0	850.7	969.2	6.5	2.5	2.6
135.0	801.7	748.5	854.9	6.6	2.6	2.5
140.0	708.3	660.5	756.1	6.8	2.8	2.5
145.0	627.4	584.4	670.5	6.9	2.9	2.4
150.0	557.2	518.4	596.1	7.0	3.0	2.3
155.0	496.1	461.0	531.3	7.1	3.1	2.3

B57885S0303J000						
R/T No.	8018					
T (°C)	B _{25/100} = 3964 K, R ₂₅ = 30000 Ω, T _R = 25 °C, ΔR _R /R _R = ± 5%					
	R _{nom} [Ω]	R _{min} [Ω]	R _{max} [Ω]	ΔR _R /R _R [±%]	ΔT[±°C]	α (%/K)
-55.0	2472200	2226900	2717600	9.9	1.4	7.0
-50.0	1750300	1583700	1916900	9.5	1.4	6.8
-45.0	1253200	1138800	1367700	9.1	1.4	6.6
-40.0	907060	827630	986480	8.8	1.4	6.4
-35.0	663280	607570	718990	8.4	1.4	6.2
-30.0	489810	450340	529280	8.1	1.4	6.0
-25.0	365130	336910	393350	7.7	1.3	5.8
-20.0	274640	254280	295000	7.4	1.3	5.6
-15.0	208370	193560	223190	7.1	1.3	5.4
-10.0	159410	148540	170270	6.8	1.3	5.3
-5.0	122920	114880	130950	6.5	1.3	5.1
0.0	95501	89516	101490	6.3	1.3	5.0
5.0	74745	70255	79234	6.0	1.2	4.8
10.0	58911	55521	62301	5.8	1.2	4.7
15.0	46745	44168	49321	5.5	1.2	4.6
20.0	37332	35362	39302	5.3	1.2	4.4
25.0	30000	28500	31500	5.0	1.2	4.3
30.0	24253	22975	25531	5.3	1.3	4.2
35.0	19720	18639	20801	5.5	1.3	4.1
40.0	16123	15206	17040	5.7	1.4	4.0
45.0	13252	12472	14032	5.9	1.5	3.9
50.0	10949	10284	11615	6.1	1.6	3.8
55.0	9091	8521	9660	6.3	1.7	3.7
60.0	7584	7095	8073	6.4	1.8	3.6
65.0	6356	5935	6777	6.6	1.9	3.5
70.0	5351	4987	5714	6.8	2.0	3.4
75.0	4524	4209	4838	7.0	2.1	3.3
80.0	3840	3567	4114	7.1	2.2	3.2
85.0	3273	3035	3511	7.3	2.3	3.2
90.0	2800	2592	3008	7.4	2.4	3.1
95.0	2405	2223	2587	7.6	2.5	3.0
100.0	2073	1912	2233	7.7	2.6	2.9
105.0	1792	1651	1933	7.9	2.7	2.9
110.0	1555	1431	1680	8.0	2.9	2.8
115.0	1354	1244	1464	8.1	3.0	2.7
120.0	1182	1085	1280	8.3	3.1	2.7
125.0	1036	948.9	1123	8.4	3.2	2.6
130.0	910.0	832.5	987.4	8.5	3.3	2.6
135.0	801.7	732.5	870.9	8.6	3.4	2.5
140.0	708.3	646.3	770.3	8.8	3.6	2.5
145.0	627.4	571.8	683.1	8.9	3.7	2.4
150.0	557.2	507.2	607.3	9.0	3.8	2.3
155.0	496.1	451.1	541.2	9.1	4.0	2.3

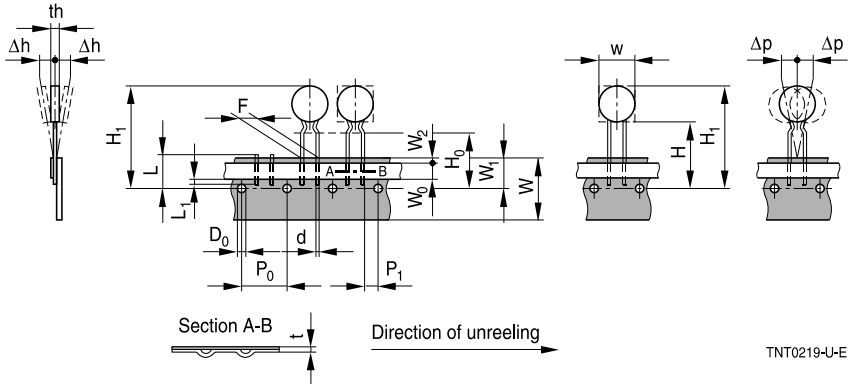
Taping and packing
1 Taping of radial leaded NTC thermistors
Dimensions and tolerances
Lead spacing $F = 2.5$ mm and 5.0 mm (taping to IEC 60286-2)

Dimensions (mm)

	Lead spacing 2.5 mm	Lead spacing 5 mm	Tolerance of lead spacing 2.5/5 mm	Remarks
b	11.0	11.5	max.	
s	5.0	6.0	max.	
d	0.5/0.6	0.5/0.6	±0.05	
P ₀	12.7	12.7	±0.3	±1 mm / 20 sprocket holes
P ₁	5.1	3.85	±0.7	
F	2.5	5.0	+0.6/-0.1	
Δh	0	0	±2.0	measured at top of component body
Δp	0	0	±1.3	
W	18.0	18.0	±0.5	
W ₀	5.5	5.5	min.	peel-off force ≥5 N
W ₁	9.0	9.0	+0.75/-0.5	
W ₂	3.0	3.0	max.	
H	18.0	18.0	+2.0/-0	
H ₀	16.0	16.0	±0.5	
H ₁	32.2	32.2	max.	
D ₀	4.0	4.0	±0.2	
t	0.9	0.9	max.	without wires
L	11.0	11.0	max.	
L ₁	4.0	4.0	max.	

Types of packing

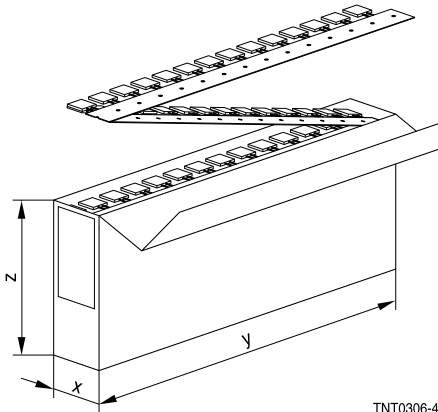
Ammo packing



TNT0306-4

Ammo type	x	y	z
I	80	240	210

Packing unit: 1000 - 2000 pcs./reel

Reel packing

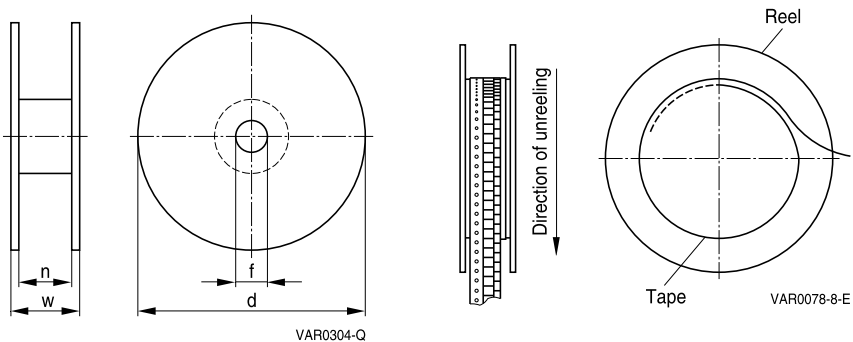
Packing unit: 1000 - 2000 pcs./reel
Reel dimensions (in mm)

Reel type	d	f	n	w
I	360 max.	31 ±1	approx. 45	54 max.
II	500 max.	23 ±1	approx. 59	72 max.

Cassette packing

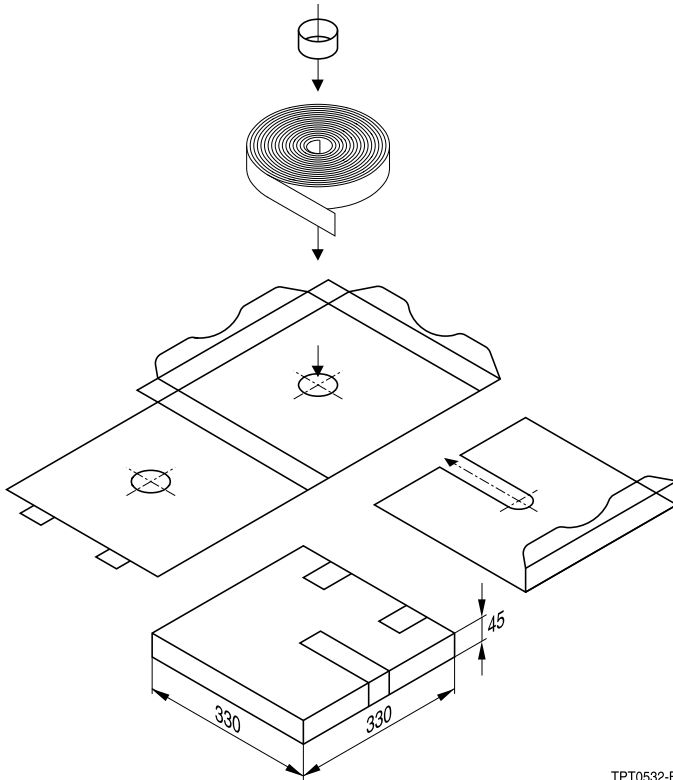

TPT0532-B

Packing unit: 1000 - 2000 pcs./cassette

Bulk packing

The components are packed in cardboard boxes, the size of which depends on the order quantity.

2 Packing codes

The last two digits of the complete ordering code state the packing mode:

Last two digits			
00, 01, 02, 03, 04, 05, 06, 07, 08	–	Bulk	–
40	–	Bulk	–
45	–	Bulk	–
50	Radial leads, kinked	Cardboard tape	Cassette packing
51	Radial leads, kinked	Cardboard tape	360 or 500-mm reel packing
52	Radial leads, straight	Cardboard tape	Cassette packing
53	Radial leads, straight	Cardboard tape	360 or 500-mm reel packing
54	Radial leads, kinked	Cardboard tape	AMMO packing
55	Radial leads, straight	Cardboard tape	AMMO packing
60	SMD	Cardboard tape	180-mm reel packing
62	SMD	Blister tape	180-mm reel packing
70	SMD	Cardboard tape	330-mm reel packing
72	SMD	Blister tape	330-mm reel packing

(If no packing code is indicated, this corresponds to 40)

Example 1:	B57164K0102J000	Bulk
	B57164K0102J052	Cardboard tape, cassette packing
Example 2:	B57881S0103F002	Bulk
	B57881S0103F251	Cardboard tape, reel packing

Mounting instructions

1 Soldering

1.1 Leaded NTC thermistors

Leaded thermistors comply with the solderability requirements specified by CECC.

When soldering, care must be taken that the NTC thermistors are not damaged by excessive heat. The following maximum temperatures, maximum time spans and minimum distances have to be observed:

	<i>Dip soldering</i>	<i>Iron soldering</i>
Bath temperature	max. 260 °C	max. 360 °C
Soldering time	max. 4 s	max. 2 s
Distance from thermistor	min. 6 mm	min. 6 mm

Under more severe soldering conditions the resistance may change.

1.2 Leadless NTC thermistors

In case of NTC thermistors without leads, soldering is restricted to devices which are provided with a solderable metallization. The temperature shock caused by the application of hot solder may produce fine cracks in the ceramic, resulting in changes in resistance.

To prevent leaching of the metallization, solder with silver additives or with a low tin content should be used. In addition, soldering methods should be employed which permit short soldering times.

2 Clamp contacting

Pressure contacting by means of clamps is particularly suitable for applications involving frequent switching and high turn-on powers.

3 Robustness of terminations (leaded types)

The leads meet the requirements of IEC 60068-2-21. They may not be bent closer than 4 mm from the solder joint on the thermistor body or from the point at which they leave the feed-throughs. During bending, any mechanical stress at the outlet of the leads must be removed. The bending radius should be at least 0.75 mm.

Tensile strength: Test Ua1:

Leads	$\varnothing \leq 0.25 \text{ mm} =$	1.0 N
	$0.25 < \varnothing \leq 0.35 \text{ mm} =$	2.5 N
	$0.35 < \varnothing \leq 0.50 \text{ mm} =$	5.0 N
	$0.50 < \varnothing \leq 0.80 \text{ mm} =$	10.0 N
	$0.80 < \varnothing \leq 1.25 \text{ mm} =$	20.0 N

Bending strength: Test Ub:

Two 90°-bends in opposite directions at a weight of 0.25 kg.

Torsional strength: Test Uc: severity 2

The lead is bent by 90° at a distance of 6 to 6.5 mm from the thermistor body.

The bending radius of the leads should be approx. 0.75 mm. Two torsions of 180° each (severity 2).

When subjecting leads to mechanical stress, the following should be observed:

Tensile stress on leads

During mounting and operation tensile forces on the leads are to be avoided.

Bending of leads

Bending of the leads directly on the thermistor body is not permissible.

A lead may be bent at a minimum distance of twice the wire's diameter +2 mm from the solder joint on the thermistor body. During bending the wire must be mechanically relieved at its outlet. The bending radius should be at least 0.75 mm.

Twisting of leads

The twisting (torsion) by 180° of a lead bent by 90° is permissible at 6 mm from the bottom of the thermistor body.

4 Sealing and potting

When thermistors are sealed, potted or overmolded, there must be no mechanical stress caused by thermal expansion during the production process (curing / overmolding process) and during later operation. The upper category temperature of the thermistor must not be exceeded. Ensure that the materials used (sealing / potting compound and plastic material) are chemically neutral.

5 Cleaning

If cleaning is necessary, mild cleaning agents such as ethyl alcohol and cleaning gasoline are recommended. Cleaning agents based on water are not allowed. Ultrasonic cleaning methods are permissible.

6 Storage

In order to maintain their solderability, thermistors must be stored in a non-corrosive atmosphere. Humidity, temperature and container materials are critical factors.

Do not store SMDs where they are exposed to heat or direct sunlight. Otherwise, the packing material may be deformed or SMDs may stick together, causing problems during mounting. After opening the factory seals, such as polyvinyl-sealed packages, use the SMDs as soon as possible.

The components should be left in the original packing. Touching the metallization of unsoldered thermistors may change their soldering properties.

Storage temperature: $-25\text{ }^{\circ}\text{C}$ up to $45\text{ }^{\circ}\text{C}$

Relative humidity (without condensation): $\leq 75\%$ annual mean

$< 95\%$, maximum 30 days per annum

Solder the thermistors listed in this data book after shipment from EPCOS within the time specified:

SMDs: 12 months

Leaded components: 24 months

Cautions and warnings General

See "Important notes" at the end of this document.

Storage

- Store thermistors only in original packaging. Do not open the package prior to storage.
- Storage conditions in original packaging: storage temperature $-25\text{ °C} \dots +45\text{ °C}$, relative humidity $\leq 75\%$ annual mean, $< 95\%$ maximum 30 days per annum, dew precipitation is inadmissible.
- Do not store thermistors where they are exposed to heat or direct sunlight. Otherwise, the packing material may be deformed or components may stick together, causing problems during mounting.
- Avoid contamination of thermistor surface during storage, handling and processing.
- Avoid storage of thermistors in harmful environments like corrosive gases (SO_x , Cl etc).
- Use the components as soon as possible after opening the factory seals, i.e. the polyvinyl-sealed packages.
- Solder thermistors within the time specified after shipment from EPCOS.
For leaded components this is 24 months, for SMDs 12 months.

Handling

- NTC thermistors must not be dropped. Chip-offs or any other damage must not be caused during handling of NTCs.
- Do not touch components with bare hands. Gloves are recommended.
- Avoid contamination of thermistor surface during handling.

Bending / twisting leads

- A lead (wire) may be bent at a minimum distance of twice the wire's diameter plus 4 mm from the component head or housing. When bending ensure the wire is mechanically relieved at the component head or housing. The bending radius should be at least 0.75 mm.
- Twisting (torsion) by 180° of a lead bent by 90° is permissible at 6 mm from the bottom of the thermistor body.

Soldering

- Use resin-type flux or non-activated flux.
- Insufficient preheating may cause ceramic cracks.
- Rapid cooling by dipping in solvent is not recommended.
- Complete removal of flux is recommended.

Mounting

- Ensure that no thermo-mechanical stress occurs due to production processes (curing or overmolding processes) when thermistors are sealed, potted or overmolded or during their subsequent operation. The maximum temperature of the thermistor must not be exceeded. Ensure that the materials used (sealing/potting compound and plastic material) are chemically neutral.
- Electrodes/contacts must not be scratched or damaged before/during/after the mounting process.
- Contacts and housing used for assembly with the thermistor must be clean before mounting.
- Ensure that adjacent materials are designed for operation at temperatures comparable to the surface temperature of the thermistor. Be sure that surrounding parts and materials can withstand the temperature.
- Avoid contamination of the thermistor surface during processing.
- The connections of sensors (e.g. cable end, wire end, plug terminal) may only be exposed to an environment with normal atmospheric conditions.
- Tensile forces on cables or leads must be avoided during mounting and operation.
- Bending or twisting of cables or leads directly on the thermistor body is not permissible.
- Avoid using chemical substances as mounting aids. It must be ensured that no water or other liquids enter the NTC thermistors (e.g. through plug terminals). In particular, water based substances (e.g. soap suds) must not be used as mounting aids for sensors.

Operation

- Use thermistors only within the specified operating temperature range.
- Use thermistors only within the specified power range.
- Environmental conditions must not harm the thermistors. Only use the thermistors under normal atmospheric conditions or within the specified conditions.
- Contact of NTC thermistors with any liquids and solvents should be prevented. It must be ensured that no water enters the NTC thermistors (e.g. through plug terminals). For measurement purposes (checking the specified resistance vs. temperature), the component must not be immersed in water but in suitable liquids (e.g. Galden).
- Avoid dewing and condensation unless thermistor is specified for these conditions.
- Bending or twisting of cables and/or wires is not permissible during operation of the sensor in the application.
- Be sure to provide an appropriate fail-safe function to prevent secondary product damage caused by malfunction.

This listing does not claim to be complete, but merely reflects the experience of EPCOS AG.

Symbols and terms

Symbol	English	German
A	Area	Fläche
AWG	American Wire Gauge	Amerikanische Norm für Drahtquerschnitte
B	B value	B-Wert
B _{25/100}	B value determined by resistance measurement at 25 °C and 100 °C	B-Wert, ermittelt durch Widerstandsmessungen bei 25 °C und 100 °C
C _{th}	Heat capacitance	Wärmekapazität
I	Current	Strom
N	Number (integer)	Anzahl (ganzzahliger Wert)
P ₂₅	Maximum power at 25 °C	Maximale Leistung bei 25 °C
P _{diss}	Power dissipation	Verlustleistung
P _{ei}	Electrical power	Elektrische Leistung
P _{max}	Maximum power within stated temperature range	Maximale Leistung im angegebenen Temperaturbereich
$\Delta R_B/R_B$	Resistance tolerance caused by spread of B value	Widerstandstoleranz, die durch die Streuung des B-Wertes verursacht wird
R _{ins}	Insulation resistance	Isolationswiderstand
R _p	Parallel resistance	Parallelwiderstand
R _R	Rated resistance	Nennwiderstand
$\Delta R_R/R_R$	Resistance tolerance	Widerstandstoleranz
R _S	Series resistance	Serienwiderstand
R _T	Resistance at temperature T (e.g. R ₂₅ = resistance at 25 °C)	Widerstand bei Temperatur T (z.B. R ₂₅ = Widerstand bei 25 °C)
T	Temperature	Temperatur
ΔT	Temperature tolerance	Temperaturtoleranz
t	Time	Zeit
T _A	Ambient temperature	Umgebungstemperatur
T _{max}	Upper category temperature	Obere Grenztemperatur (Kategorietemperatur)
T _{min}	Lower category temperature	Untere Grenztemperatur (Kategorietemperatur)
T _{op}	Operating temperature	Betriebstemperatur
T _R	Rated temperature	Nenntemperatur
T _{surf}	Surface temperature	Oberflächentemperatur
V	Voltage	Spannung
V _{ins}	Insulation test voltage	Isolationsprüfspannung
V _{op}	Operating voltage	Betriebsspannung
V _{test}	Test voltage	Prüfspannung

Symbol	English	German
α	Temperature coefficient	Temperaturkoeffizient
Δ	Tolerance, change	Toleranz, Änderung
δ_{th}	Dissipation factor	Wärmeleitwert
τ_c	Thermal cooling time constant	Thermische Abkühlzeitkonstante
τ_a	Thermal time constant	Thermische Zeitkonstante

Abbreviations / Notes

Symbol	English	German
<u>SMD</u>	Surface-mounted devices	Oberflächenmontierbares Bauelement
*	To be replaced by a number in ordering codes, type designations etc.	Platzhalter für Zahl im Bestellnummerncode oder für die Typenbezeichnung.
+	To be replaced by a letter. All dimensions are given in mm. The commas used in numerical values denote decimal points.	Platzhalter für einen Buchstaben. Alle Maße sind in mm angegeben. Verwendete Kommas in Zahlenwerten bezeichnen Dezimalpunkte.

Important notes

The following applies to all products named in this publication:

1. Some parts of this publication contain **statements about the suitability of our products for certain areas of application**. These statements are based on our knowledge of typical requirements that are often placed on our products in the areas of application concerned. We nevertheless expressly point out **that such statements cannot be regarded as binding statements about the suitability of our products for a particular customer application**. As a rule, EPCOS is either unfamiliar with individual customer applications or less familiar with them than the customers themselves. For these reasons, it is always ultimately incumbent on the customer to check and decide whether an EPCOS product with the properties described in the product specification is suitable for use in a particular customer application.
2. We also point out that **in individual cases, a malfunction of electronic components or failure before the end of their usual service life cannot be completely ruled out in the current state of the art, even if they are operated as specified**. In customer applications requiring a very high level of operational safety and especially in customer applications in which the malfunction or failure of an electronic component could endanger human life or health (e.g. in accident prevention or lifesaving systems), it must therefore be ensured by means of suitable design of the customer application or other action taken by the customer (e.g. installation of protective circuitry or redundancy) that no injury or damage is sustained by third parties in the event of malfunction or failure of an electronic component.
3. **The warnings, cautions and product-specific notes must be observed.**
4. In order to satisfy certain technical requirements, **some of the products described in this publication may contain substances subject to restrictions in certain jurisdictions (e.g. because they are classed as hazardous)**. Useful information on this will be found in our Material Data Sheets on the Internet (www.epcos.com/material). Should you have any more detailed questions, please contact our sales offices.
5. We constantly strive to improve our products. Consequently, **the products described in this publication may change from time to time**. The same is true of the corresponding product specifications. Please check therefore to what extent product descriptions and specifications contained in this publication are still applicable before or when you place an order. We also **reserve the right to discontinue production and delivery of products**. Consequently, we cannot guarantee that all products named in this publication will always be available. The aforementioned does not apply in the case of individual agreements deviating from the foregoing for customer-specific products.
6. Unless otherwise agreed in individual contracts, **all orders are subject to the current version of the "General Terms of Delivery for Products and Services in the Electrical Industry" published by the German Electrical and Electronics Industry Association (ZVEI)**.
7. The trade names EPCOS, BAOKE, Alu-X, CeraDiode, CSMP, CSSP, CTVS, DSSP, MiniBlue, MKK, MLSC, MotorCap, PCC, PhaseCap, PhaseCube, PhaseMod, SIFERRIT, SIFI, SIKOREL, SilverCap, SIMDAD, SIMID, SineFormer, SIOV, SIP5D, SIP5K, ThermoFuse, WindCap are **trademarks registered or pending** in Europe and in other countries. Further information will be found on the Internet at www.epcos.com/trademarks.



Компания «ЭлектроПласт» предлагает заключение долгосрочных отношений при поставках импортных электронных компонентов на взаимовыгодных условиях!

Наши преимущества:

- Оперативные поставки широкого спектра электронных компонентов отечественного и импортного производства напрямую от производителей и с крупнейших мировых складов;
- Поставка более 17-ти миллионов наименований электронных компонентов;
- Поставка сложных, дефицитных, либо снятых с производства позиций;
- Оперативные сроки поставки под заказ (от 5 рабочих дней);
- Экспресс доставка в любую точку России;
- Техническая поддержка проекта, помощь в подборе аналогов, поставка прототипов;
- Система менеджмента качества сертифицирована по Международному стандарту ISO 9001;
- Лицензия ФСБ на осуществление работ с использованием сведений, составляющих государственную тайну;
- Поставка специализированных компонентов (Xilinx, Altera, Analog Devices, Intersil, Interpoint, Microsemi, Aeroflex, Peregrine, Syfer, Eurofarad, Texas Instrument, Miteq, Cobham, E2V, MA-COM, Hittite, Mini-Circuits, General Dynamics и др.);

Помимо этого, одним из направлений компании «ЭлектроПласт» является направление «Источники питания». Мы предлагаем Вам помощь Конструкторского отдела:

- Подбор оптимального решения, техническое обоснование при выборе компонента;
- Подбор аналогов;
- Консультации по применению компонента;
- Поставка образцов и прототипов;
- Техническая поддержка проекта;
- Защита от снятия компонента с производства.



Как с нами связаться

Телефон: 8 (812) 309 58 32 (многоканальный)

Факс: 8 (812) 320-02-42

Электронная почта: org@eplast1.ru

Адрес: 198099, г. Санкт-Петербург, ул. Калинина, дом 2, корпус 4, литера А.