

## *BMD-300 Series Evaluation Kit User Guide*

The **BMD-300 Series Evaluation Kits** from Rigado allow for stand-alone use of the **BMD-300**, **BMD-301** and **BMD-350** modules featuring the Nordic nRF52832 RF System on Chip (SoC).

This guide provides setup instructions for starting development and describes the hardware functionality of the **BMD-300 Series Evaluation Kits**.



### 1. Overview

The BMD-300 Series Evaluation Kits provide a great starting point for almost any Bluetooth Smart (4.2 Low Energy) project. All features of the BMD-300 are easily accessed from the evaluation board. A simple USB connection provides power, programming, and a virtual COM port. Four user buttons are available, as well as four LEDs and a reset button. All 32 GPIO are available on headers that are compatible with the Arduino form factor. This allows easy use of the Rigado BMD-300 Series Shields, as well as many existing Arduino shields. Current sense resistors allow for measuring current into the BMD-300 Series module and into the shield.

#### 1.1. Key Features

- BMD-300 Series Module
- On-board programming and debug (Segger J-Link-OB)
- Able to program external modules
- Virtual COM port over USB
- Full GPIO pin out of the BMD-300 / nRF52832
- Buttons and LEDs for user interaction
- NFC antenna connector
- 32.768kHz Crystal
- CR2032 battery holder

## Table of Contents

<b>1. Overview</b>	<b>1</b>
1.1. Key Features	1
<b>2. Useful Tools</b>	<b>3</b>
<b>3. Hardware Kit</b>	<b>3</b>
<b>4. Application Firmware Development</b>	<b>4</b>
4.1. Set up tool chain	4
4.2. Connect BMD-300 Evaluation Kit to computer	4
4.3. Program BMD-300 Evaluation Kit with the S132 Soft Device	5
4.4. Set up the Application Project	6
<b>5. Hardware Description</b>	<b>7</b>
5.1. Power	7
5.1. Reset	8
5.2. Buttons	9
5.1. LEDs	9
5.2. Virtual COM Port	10
5.3. 32kHz Crystal Oscillator	10
5.4. NFC Connector	10
5.5. Current Sensing Headers	11
5.6. External Segger J-Link™ Debug Interface	11
5.7. GPIO Jumpers	12
5.8. Header Pin-out	13
5.9. BMD-300 Series Module Pinout	15
<b>6. Life Support Policy</b>	<b>16</b>
<b>7. Document History</b>	<b>16</b>
<b>8. Related Documents</b>	<b>16</b>

## Table of Figures

Figure 1 – BMD-300 Evaluation Board (Top View)	3
Figure 2 – Segger J-Link DLL Updater	4
Figure 3 – nRFgo Studio with J-Link Interface	5
Figure 4 – nRFgo Studio SoftDevice Window	5
Figure 5 – J-Link Selection	6
Figure 6 – J-Link Identification	6
Figure 7 – Assembly Drawing (Top View)	7
Figure 8 – Schematic – Power Supply	8
Figure 9 – Schematic – Reset	9
Figure 10 – Schematic – User Buttons	9
Figure 11 – Schematic – User LEDs	9
Figure 12 – Schematic - 32KHz Crystal	10
Figure 13 – NFC Connector	10
Figure 14 – Current Sensing Header Layout	11
Figure 15 – External J-Link Debug Interface	11
Figure 16 – GPIOs disconnected from I/O headers	12
Figure 17 – GPIO Jumper Summary	12
Figure 18 – BMD-300 Series Evaluation Board Pin-out	13
Figure 19 – BMD-300 Series Module Pin-out	15

## 2. Useful Tools

Below is a list of tools that aid in development with the BMD-300 Series Bluetooth modules. Not all tools will be required depending on which software suite is used.

<i>Tool</i>	<i>Description</i>
Rigado Toolbox for iOS and Android	The Rigado Toolbox provides a way for Rigado Module customers to configure their Rigado Beacons and other out of the box firmware features. The toolbox also provides the ability to securely update device firmware. The secure update feature is available to module customers.
nRF Master Control Panel for Android	A Nordic tool for Android devices to allow active scanning for Bluetooth low energy devices and communication.
Nordic nRFgo Studio	The Nordic software suite is used to program and configure Nordic nRF devices. It supports programming of nRF52 application, bootloader, and soft device. This tool uses the on board Segger J-Link programming interface.
Keil MDK-ARM Development Kit	A development environment designed for microcontroller applications that enables development using the nRF52 SDK application and example files.
Segger J-Link Software	Software and documentation pack for the Segger J-Link interface

## 3. Hardware Kit

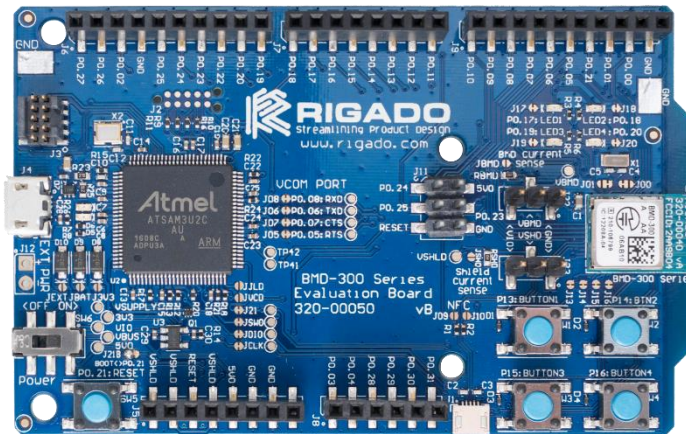

Figure 1 – BMD-300 Evaluation Board (Top View)

### BMD-300-EVAL:

- 1x BMD-300 Evaluation Board
- 1x Micro-USB Cable

### BMD-350-EVAL:

- 1x BMD-300 Evaluation Board
- 1x Micro-USB Cable

### BMD-301-EVAL:

- 1x BMD-301 Evaluation Board
- 1x Micro-USB
- 2x Bluetooth Antennas – patch and tilt-whip styles
- 1x U.FL to RP-SMA jumper cable

## 4. Application Firmware Development

This section walks through how to set up and program the BMD-300 Series Evaluation Kit with an example application.

**NOTE:** This process will erase any preloaded firmware provided by Rigado, such as the RigDFU secure bootloader and BMDware beacon and UART-BLE bridge firmware. This firmware can be found as part of our BMD Software Suite located on GitHub. Please contact Rigado to get free access ([modules@rigado.com](mailto:modules@rigado.com)).

### 4.1. Set up tool chain

1. Download and install the latest Keil MDK-ARM development kit from [www.keil.com/arm/mdk.asp](http://www.keil.com/arm/mdk.asp)
  - a. Once the Keil MDK-ARM installation is complete, Keil will launch the Pack Installer. The Keil Pack Installer manages software components for the various supported microcontrollers
  - b. The Pack Installer will automatically download any updates for the core ARM support
  - c. Once these core packs are installed and up to date, close the Pack Installer

**Note:** As of Nordic Semiconductor SDK v11.0.0, Keil Packs are no longer supported. The full SDK, with the currently released SoftDevices, is installed in step 4 below.
2. Download and install the nRFgo Studio from [www.nordicsemi.com/eng/Products/2.4GHz-RF/nRFgo-Studio](http://www.nordicsemi.com/eng/Products/2.4GHz-RF/nRFgo-Studio)
3. Download and install the latest Segger J-Link utilities from <https://www.segger.com/jlink-software.html>. When prompted to overwrite the JLinkARM.dll file, select all of the listed items and click OK:

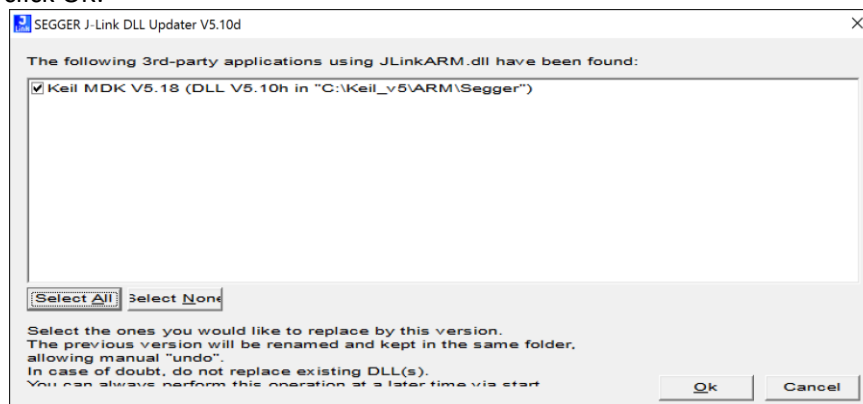

Figure 2 – Segger J-Link DLL Updater

4. Download the latest Nordic Semiconductor nRF5 SDK from [http://developer.nordicsemi.com/nRF5\\_SDK/nRF5\\_SDK\\_v11.x.x](http://developer.nordicsemi.com/nRF5_SDK/nRF5_SDK_v11.x.x). Extract the Zip file to a working folder

### 4.2. Connect BMD-300 Evaluation Kit to computer

The evaluation board is provided with an on-board Segger J-Link programmer/debugger.

1. Connect the board to a computer using the USB cable provided
2. The status LED, D5, will flash and then turn solid once the USB device is enumerated.
3. After a few seconds the computer will recognize the Evaluation Board as a J-Link device and install the USB-Virtual COM Port device driver
4. Open nRFgo Studio and verify that the J-Link interface is recognized:

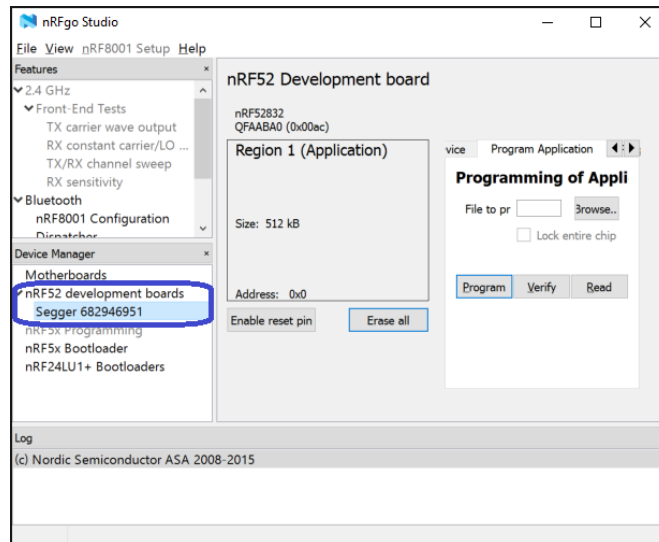

Figure 3 – nRFGo Studio with J-Link Interface

### 4.3. Program BMD-300 Evaluation Kit with the S132 Soft Device

1. Open the Nordic nRFGo Studio application. In the 'Device Manager' section, there will be a device named Segger followed by serial number under 'nRF52 development boards.' Select Segger and the device programming interface will appear in the main window
  - a. If the programming window above does not appear, try the following at a command line:
 

```
nrfjprog -f NRF52 --recover
```
  - b. Select the Segger device and continue to Step 3.
2. Click 'Erase all' to clear the device of all current programmed software
3. Select the 'Program SoftDevice' tab in the pane on the right
4. Click 'Browse...' and navigate to the location of the S132 SoftDevice (<unzipped location>\nRF5\_SDK\_11.0.0\_89a8197\components\softdevice\s132\hex). Locate and select the latest version of the SoftDevice hex file
5. Click program
6. After programming, nRFGo Studio should look similar to Figure 4 below:

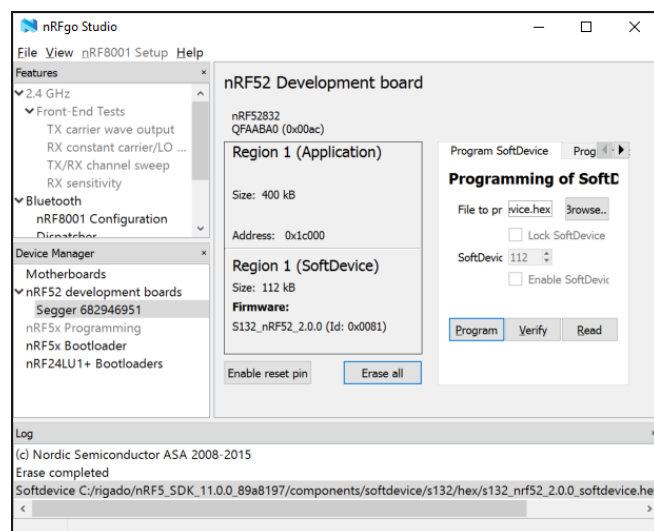





Figure 4 – nRFGo Studio SoftDevice Window

7. Close nRFGo Studio

## 4.4. Set up the Application Project

**Note:** The BMD-300 Series Evaluation Kit is directly compatible with the Nordic nRF52 DK (PCA10040)

1. Navigate to the location of the extracted examples from the SDK (typically <unzipped location>\nRF5\_SDK\_11.0.0\_89a8197\examples)
2. Select one of the examples that is labeled with "(nRF52 PCA10040)" and "s132". The Heart Rate Service Sample Application (.\\ble\_peripheral\\ble\_app\_hrs\\pca10040\\s132\\arm5\_no\_packs\\) is a good place to start. For starting on a custom application, using a template project is a good idea (such as ble\_app\_template\_s132\_pca10040)
3. Open the project file (ble\_app\_hrs\_s132\_pca10040.uvprojx) to start the Keil IDE
4. Now build ( , 'F7') to make sure all project settings are configured correctly
5. Once the build is successful, you can download the application code onto the module Board ( , 'Flash'-> 'Download')
6. Using a standard heart rate app on Android or iOS allows you to connect to the evaluation board and see the simulated heart rate
7. If you cannot program the device, go to the 'Debug' tab in 'Options for Target' ( , 'Project' -> 'Options for Target'), and select 'J-LINK/J-TRACE Cortex' from the upper right hand drop down menu

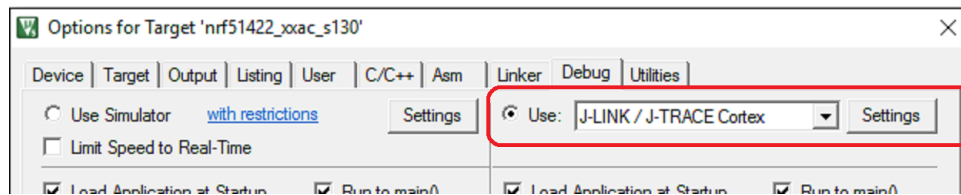

Figure 5 – J-Link Selection

8. Clicking on 'Settings' shows the serial number of the JLink under 'J-Link/J-Trace Adapter' and also shows the module's IDCODE as an SWD device under 'SW Device'

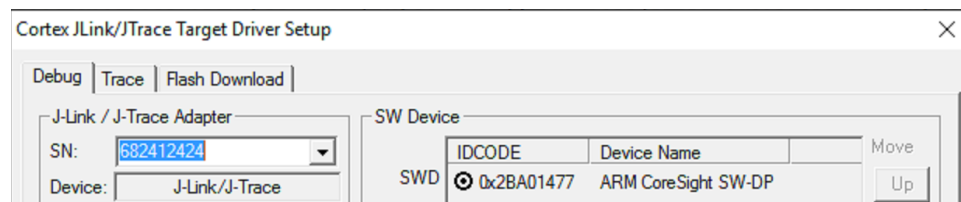

Figure 6 – J-Link Identification

## 5. Hardware Description

Design files for the BMD-300 Series Evaluation Kit may be found on the [Rigado website](#).

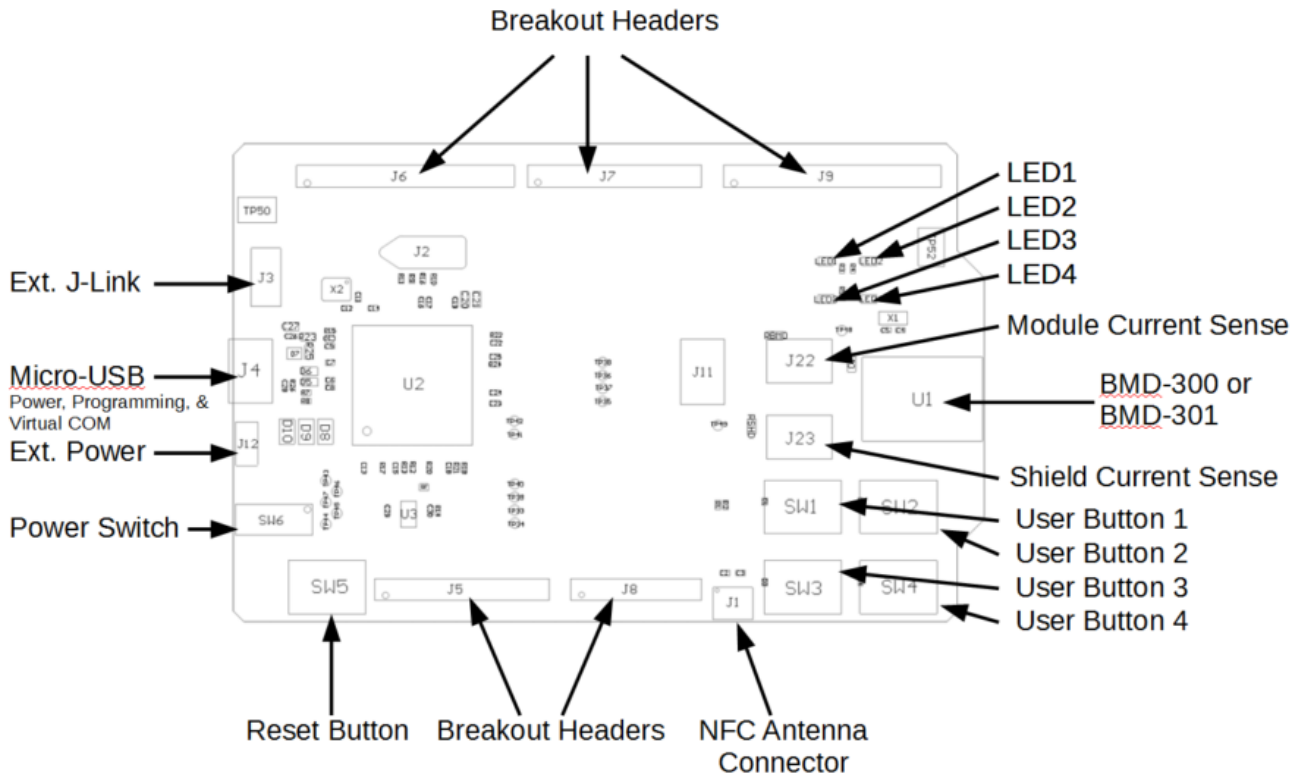

Figure 7 – Assembly Drawing (Top View)

### 5.1. Power

The BMD-300 Evaluation Board has three possible power sources: USB, a CR2032 coin cell battery, and a 0.1" through-hole connector. These power sources are diode OR'ed to prevent reverse voltage to any supply. This allows them to be used simultaneously. Solder jumpers are provided to allow by-passing any of the protection diodes eliminating the voltage drop across them. Care should be taken to not damage the supplies when the protection is by-passed.

#### Powering the Board:

Typically, power will be provided by USB though VBUS, which will supply +5V to the 3.3V LDO regulator and to the shield connector. The 3.3V LDO regulator will then power the VIO, VSHLD, and VBMD.

When powering the board from the CR2032 coin cell (3VDC) or the external power header, USB can be left disconnected. In this configuration, the interface IC is held in reset to conserve power. If the power OR'ing diodes are NOT by-passed, USB can be connected with the coin cell or external power still applied allowing for easy programming of the module.

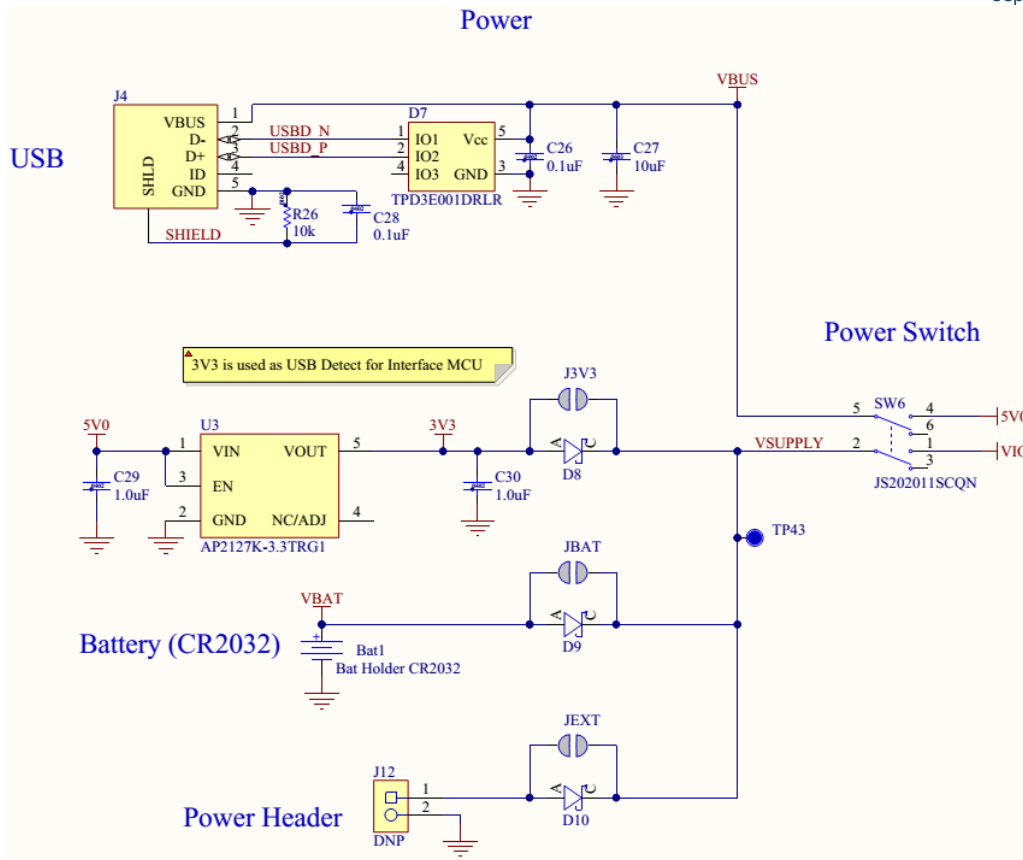

Figure 8 – Schematic – Power Supply

## 5.1. Reset

The BMD-300 Series module has a configurable hardware reset. However, P0.21 is assumed to be used as the reset pin for all Rigado and Nordic example projects, and thus the evaluation board hardware is configured to use P0.21 as a reset. The Reset button can be configured to connect to an input on the interface IC or to directly connect to P0.21.

The Reset button is connected to the IC used for the J-Link interface by default. Pressing reset while the interface IC is powered will cause a momentary reset signal on the nRESET output of the interface IC, which is connected via solder jumper to P0.21 of the BMD-300 Series module. If the Reset button is held down during power on, it will cause the interface IC to enter its bootloader mode, allowing either Segger J-Link or mbed programmer firmware to be programmed.

When the Reset button is directly connected to P0.21, it can be used as a 5th user button or as a reset button directly connected to the BMD module.

Solder jumper J21 is used to connect P0.21 of the BMD module to the nRESET net. nRESET is connected to the interface IC and to the reset connections on the Arduino headers.

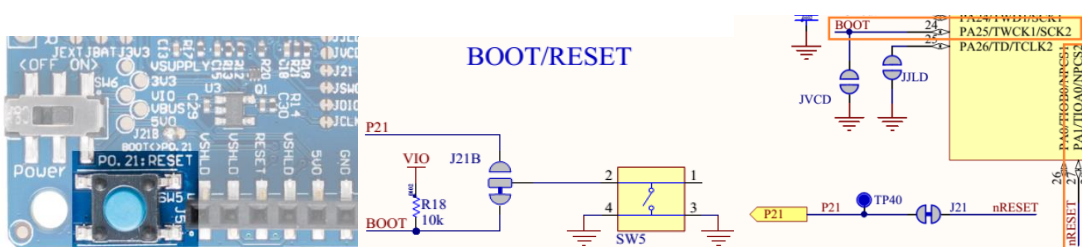



Figure 9 – Schematic – Reset

## 5.2. Buttons

The Evaluation Board has four user buttons: User 1, User 2, User 3, and User 4. All buttons are active low; they will connect to ground when pressed. The button GPIO pins must be configured with internal pull-up resistors for proper operation when using the user buttons. The buttons and ESD protection can be completely removed from the circuit by breaking the associated jumper.

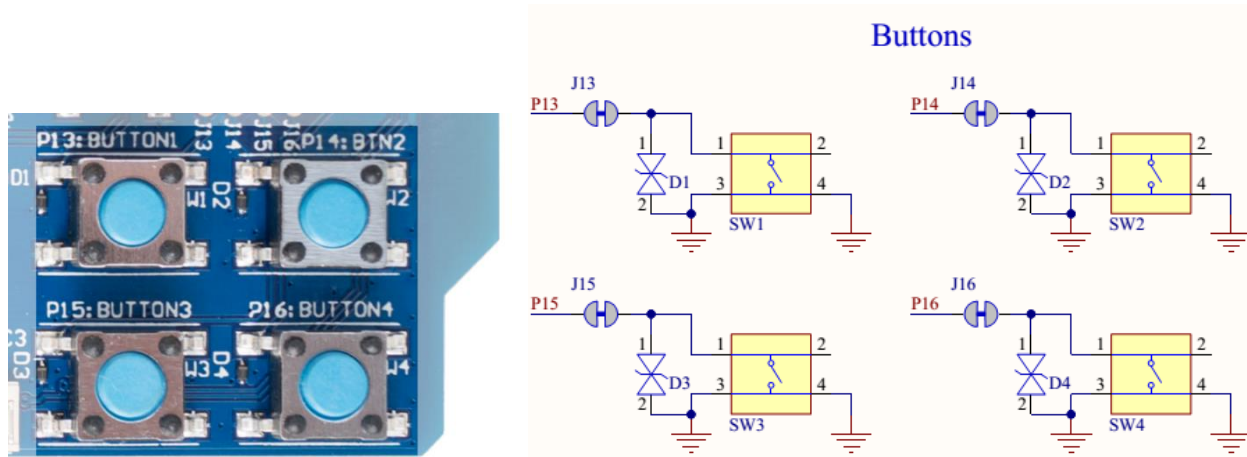

Figure 10 – Schematic – User Buttons

## 5.1. LEDs

Four User LEDs are provided on the Evaluation Board; two red and two green. LEDs are powered by VIO and are active low. The GPIO should be enabled for high drive when sinking current for the LEDs. The LEDs can be completely removed from the circuit by breaking the associated jumper.

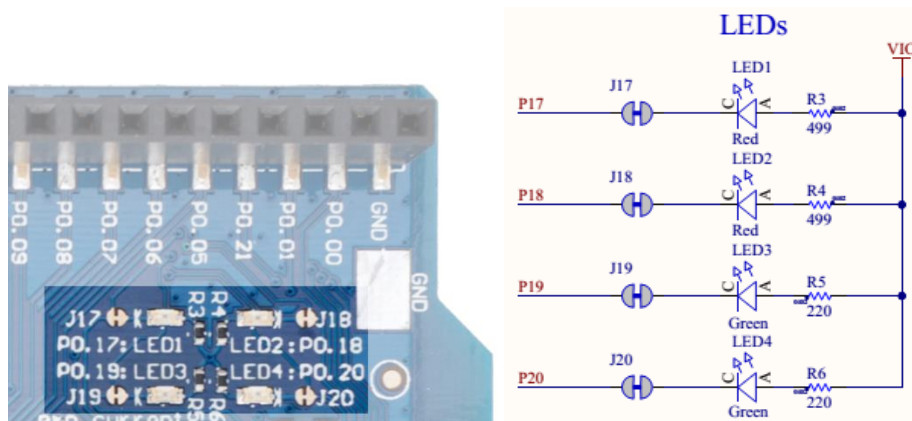

Figure 11 – Schematic – User LEDs

## 5.2. Virtual COM Port

The evaluation board allows for easy serial communication with the BMD-300 Series Modules and a connected computer. The Interface IC provide a virtual COM USB device that connects to 4 GPIO pins on the module, allowing for UART communication with or without hardware flow control. The UART lines can be completely removed from the circuit by breaking the associated jumpers.

BMD-300 Pin Name	BMD-300 Function	Jumper	Interface IC Function
P0.05	RTS	J05	CTS
P0.06	TXD	J06	RXD
P0.07	CTS	J07	TRS
P0.08	RXD	J08	TXD

## 5.3. 32kHz Crystal Oscillator

The evaluation board has a 32.768kHz Crystal Oscillator connected to the BMD-300 Series module by default. This allows the module to use any of the three available low frequency (LF) clock sources: an internal calibrated RC oscillator, an internal synthesized clock (derived from the 32MHz clock), or an external crystal oscillator. The external crystal oscillator is the most accurate and lowest power LF clock option. For applications without strict time keeping requirements, the internal calibrated RC oscillator is often suitable. The crystal is connected to the module through a solder select jumper, allowing either the crystal or the IO header to be connected to the module's GPIO pins.

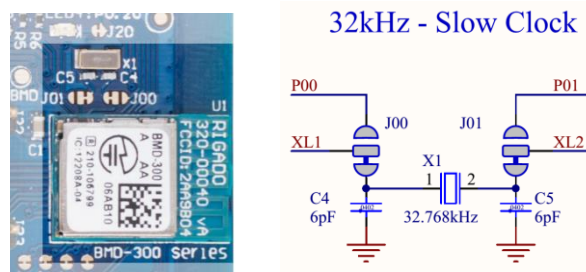

Figure 12 – Schematic - 32KHz Crystal

## 5.4. NFC Connector

Connection to an external NFC antenna is provided through a Molex flat-flex connector, Part number 051281-0594. Capacitors 'C2' and 'C3' provide tuning of the NFC antenna for resonance at 15.56MHz.

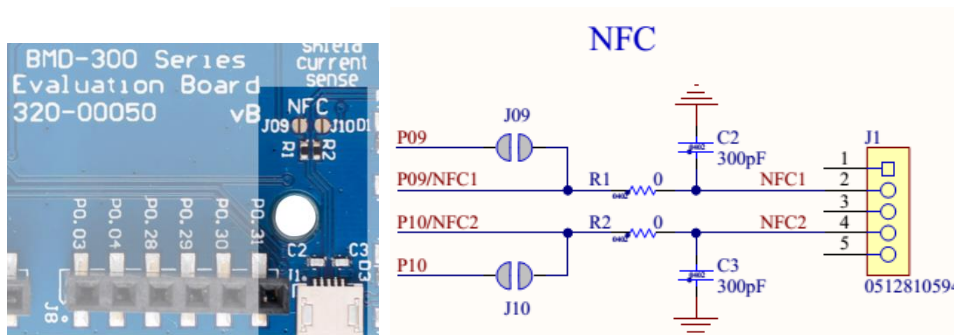

Figure 13 – NFC Connector

## 5.5. Current Sensing Headers

The evaluation board provides two current sensing headers. 'JBMD' allows for power consumption measurement of the BMD-300 Series Module and 'JSHD' allows for power consumption measurement of shields connected to the Arduino-style headers ('VSHLD' power only).

Each 3-pin 0.1" pitch header has two pins connected across a 1Ω current sense resistor powering the module or the shield, and the third pin to ground. To measure current consumption, use a multimeter or other precision voltage measurement device to measure voltage drop across pins one and two. Current can also be measured directly by removing 'RBMD' / 'RSHD' and using a current meter in series with the two voltage pins. The default hardware configuration does not require any modification of the current sense headers for the BMD-300 Evaluation Board to perform properly.

**Note:** Only current flowing through 'VBMD' into the module is measured; current sunk through GPIO pins is not measured.

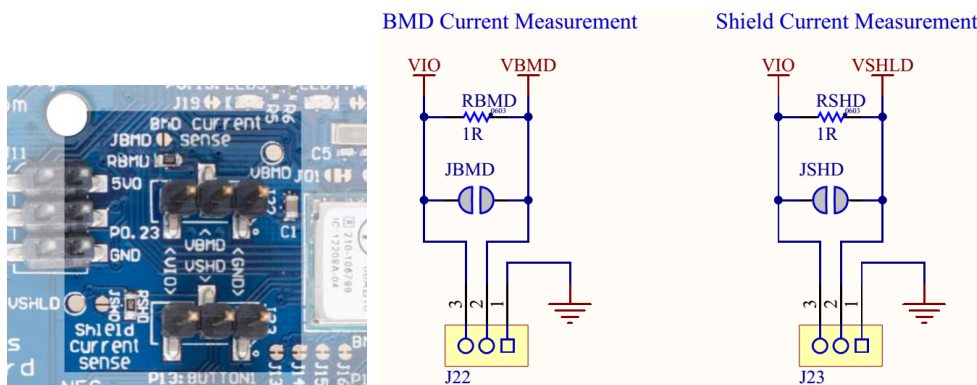

Figure 14 – Current Sensing Header Layout

## 5.6. External Segger J-Link™ Debug Interface

External target hardware can be connected to J3 for firmware programming and debug. The Segger debug interface is implemented as shown in Figure 15. J3 is implemented with a 2x5 10-pin header on 0.05" centers.

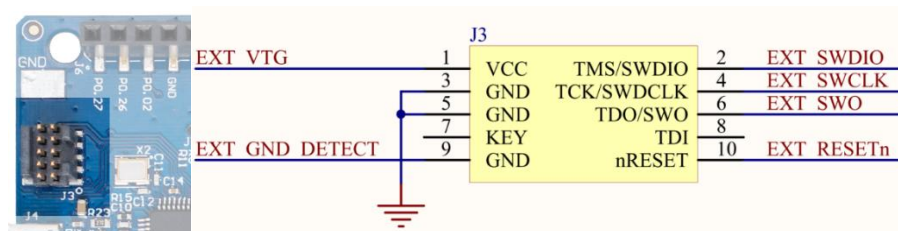

Figure 15 – External J-Link Debug Interface

In order to enable the external J-Link connection, ensure the following are implemented on the target hardware:

- EXT VTG is used by the debug interface as an input to set the debug interface voltage levels. Connect EXT VTG to the BMD-300 Series power supply (VCC) on the target hardware.
- EXT GND DETECT is used by the debug interface to detect the presence of external target hardware. Connect EXT GND DETECT to GND on the target hardware.

- Connect EXT\_SWCLK and EXT\_SWCLK to SWCLK and SWCLK on the target BMD-300, respectively.
- (Optional) Connect EXT\_SWO and/or EXT\_RESETn to P0.18 and P0.21 on the target BMD-300, respectively.
- Connect external power to the target hardware, then connect the BMD-300 Series Evaluation Board to USB.
- At this point, the debug interface will interact with the target hardware instead of the on-board BMD-300.

## 5.7. GPIO Jumpers

There are many solder bridge jumpers on the board available to allow for configurability of the GPIO. Most solder jumpers are used to remove on-board components from the module's GPIO nets, in the event that they may interfere with external circuitry added on the I/O headers. All GPIOs are directly connected to the I/O Headers by default, except P0.00 & P0.01 (32kHz crystal) and P0.09 & P0.10 (NFC antenna). These are disconnected from the I/O headers as they would interfere with the default functions.

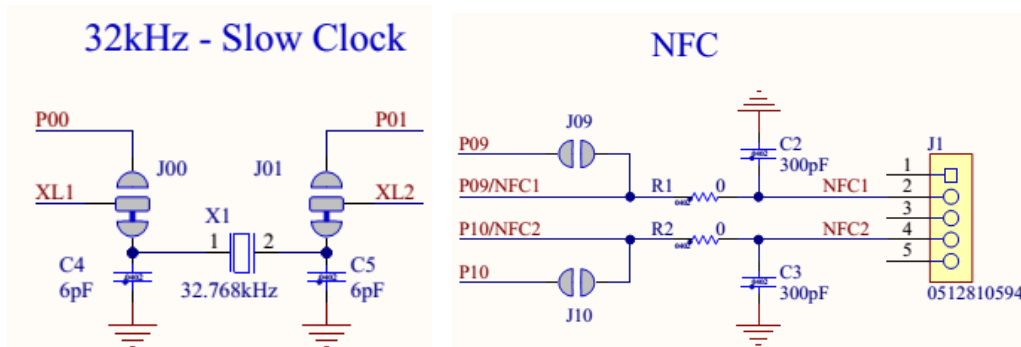

Figure 16 – GPIOs disconnected from I/O headers

The GPIO jumpers are shown on the bottom side of the BMD-300 Series Evaluation Board:

BMD-300 Series			
GPIO	Function	Jumper	HW
P00	XL1	J00	BMD PIN
P01	XL2	J01	BMD PIN
P05	RTS	J05	IF MCU
P06	TXD	J06	BMD PIN
P07	CTS	J07	BMD PIN
P08	RXD	J08	BMD PIN
P09	NFC1	J09 R1	PIN NFC
P10	NFC2	J10 R2	BMD PIN
P13	Button 1	J13	BMD PIN
P14	Button 2	J14	BMD PIN
P15	Button 3	J15	BMD PIN
P16	Button 4	J16	BMD PIN
P17	LED 1	J17	BMD PIN
P18	LED 2	J18	BMD PIN
P19	LED 3	J19	BMD PIN
P20	LED 4	J20	BMD PIN

Figure 17 – GPIO Jumper Summary

## 5.8. Header Pin-out

Headers J5 through J9 and J11 break-out the IO signals from the BMD-300 on 0.1" pitch headers.

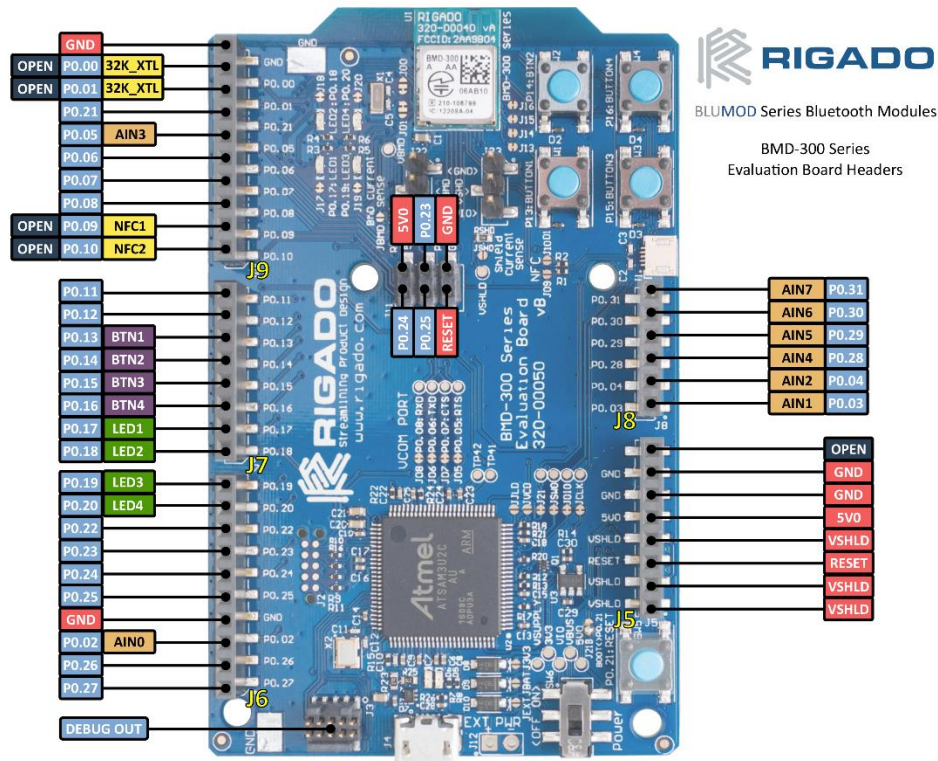

Figure 18 – BMD-300 Series Evaluation Board Pin-out

The tables below are presented relative to the positioning on the BMD-300 Series Evaluation Board

<b>Header J9</b>			
Header Pin	Pin Name	nRF52 Port	Function
10	GND		Ground
9	P0.00	P0.00	OPEN / GPIO
8	P0.01	P0.01	OPEN / GPIO
7	P0.21	P0.21	RESET / GPIO
6	P0.05	P0.05	GPIO / AIN3
5	P0.06	P0.06	GPIO
4	P0.07	P0.07	GPIO
3	P0.08	P0.08	GPIO
2	P0.09	P0.09	OPEN / GPIO
1	P0.10	P0.10	OPEN / GPIO
<b>Header J7</b>			
Header Pin	Pin Name	nRF52 Port	Function
8	P0.11	P0.11	GPIO
7	P0.12	P0.12	GPIO
6	P0.13	P0.13	GPIO
5	P0.14	P0.14	GPIO / TRACED[3]
4	P0.15	P0.15	GPIO / TRACED[2]
3	P0.16	P0.16	GPIO / TRACED[1]
2	P0.17	P0.17	GPIO
1	P0.18	P0.18	GPIO / TRACED[0]
<b>Header J6</b>			
Header Pin	Pin Name	nRF52 Port	Function
10	P0.19	P0.19	GPIO
9	P0.20	P0.20	GPIO / TRACECLK
8	P0.22	P0.22	GPIO
7	P0.23	P0.23	GPIO
6	P0.24	P0.24	GPIO
5	P0.25	P0.25	GPIO
4	GND	-	Ground
3	P0.02	P0.02	GPIO / AIN0
2	P0.26	P0.26	GPIO
1	P0.27	P0.27	GPIO

<b>Header J8</b>			
Header Pin	Pin Name	nRF52 Port	Function
6	P0.31	P0.31	GPIO / AIN7
5	P0.30	P0.30	GPIO / AIN6
4	P0.29	P0.29	GPIO / AIN5
3	P0.28	P0.28	GPIO / AIN4
2	P0.04	P0.04	GPIO / AIN2
1	P0.03	P0.03	GPIO / AIN1
<b>Header J5</b>			
Header Pin	Pin Name	nRF52 Port	Function
8	-	-	
7	GND	-	Ground
6	GND	-	Ground
5	5V0	-	+5.0V USB Power
4	VSHLD	-	+3.3V Shield Power
3	RESET	P0.21	RESET
2	VSHLD	-	+3.3V Shield Power
1	VSHLD	-	+3.3V Shield Power

<b>Header J11</b>			
Header Pin	Pin Name	nRF52 Port	Function
1	P0.24	P0.24	GPIO
2	5V0	-	+5.0V USB Power
3	P0.25	P0.25	GPIO
4	P0.23	P0.23	GPIO
5	nRESET	P0.21	RESET
6	GND		Ground

## 5.9. BMD-300 Series Module Pinout

### Top View

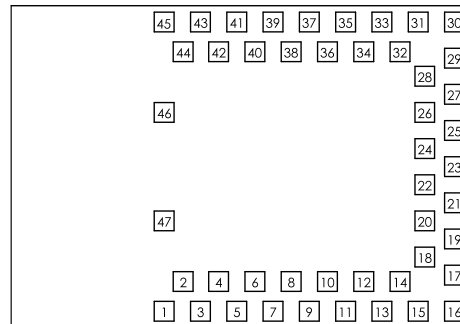

Figure 19 – BMD-300 Series Module Pin-out

Pin	Name	Direction	Description
6	P0.25	In/Out	GPIO <sup>3</sup>
7	P0.26	In/Out	GPIO <sup>3</sup>
8	P0.27	In/Out	GPIO <sup>3</sup>
9	P0.28	In/Out	GPIO/AIN4 <sup>3</sup>
10	P0.29	In/Out	GPIO/AIN5 <sup>3</sup>
11	P0.30	In/Out	GPIO/AIN6 <sup>3</sup>
12	P0.31	In/Out	GPIO/AIN7 <sup>3</sup>
13	P0.00	In/Out	GPIO/XTAL1 (32.768kHz)
14	P0.01	In/Out	GPIO/XTAL2 (32.768kHz)
15	P0.02	In/Out	GPIO/AIN0
19	P0.03	In/Out	GPIO/AIN1
20	P0.04	In/Out	GPIO/AIN2
21	P0.05	In/Out	GPIO/AIN3
22	P0.06	In/Out	GPIO
23	P0.07	In/Out	GPIO
24	P0.08	In/Out	GPIO
25	P0.09	In/Out	GPIO/NFC1
26	P0.10	In/Out	GPIO/NFC2
27	P0.11	In/Out	GPIO
28	P0.12	In/Out	GPIO
31	P0.13	In/Out	GPIO
32	P0.14	In/Out	GPIO/TRACEDATA[3]
33	P0.15	In/Out	GPIO/TRACEDATA[2]
34	P0.16	In/Out	GPIO/TRACEDATA[1]
35	P0.17	In/Out	GPIO
36	P0.18	In/Out	GPIO/TRACEDATA[0]/SWO
37	P0.19	In/Out	GPIO
38	P0.20	In/Out	GPIO/TRACECLK
39	P0.21	In/Out	GPIO/ RESET <sup>1</sup>
40	P0.22	In/Out	GPIO <sup>3</sup>
41	P0.23	In/Out	GPIO <sup>3</sup>
42	P0.24	In/Out	GPIO <sup>3</sup>
43	SWCLK	In	SWD Clock
44	SWDIO	In/Out	SWD IO
17	VCC	Power	+1.7V to +3.6V <sup>2</sup>
1, 2, 3, 4, 5, 16, 18, 29, 30, 45, 46, 47	GND	Power	Electrical Ground

Note 1: The RESET function can be assigned to another GPIO during programming. P0.21 is the default used by Rigado and Nordic example applications and development kits.

Note 2: An internal 4.7μF bulk capacitor is included on the module. However, it is good design practice to add additional bulk capacitance as required for your application, i.e. those with heavy GPIO usage and/or current draw.

Note 3: These pins are in close proximity to the nRF52 radio power supply and antenna pins. Radio performance parameters, such as sensitivity, may be affected by high frequency digital I/O with large sink/source current on these pins. Nordic recommends using only low frequency, low-drive functions when possible.

## 6. Life Support Policy

This product is not designed to be used in a life support device or system, or in applications where there is potential for a failure or malfunction to, directly or indirectly, cause significant injury. By using this product in an application that poses these risks, such as described above, the customer is agreeing to indemnify Rigado for any damages that result.

## 7. Document History

Revision	Date	Changes / Notes
1.0	2016-05-04	Initial release
1.0.1	2016-05-06	Added link to reference design files in Section 4, updated logo
1.1	2016-07-28	Updated images, Added section on External J-Link connector, corrected section numbering
1.2	2016-09-09	Added BMD-350 ordering information, document links

## 8. Related Documents

### Rigado Documents:

- [BMD-300-Series-DS: Module Datasheet](#)
- [MAC Address Provisioning](#)
- [RIGDFU-DS-1: RigDFU Secure Bootloader Datasheet](#)
- [BMDWARE-DS-1: BMDware Datasheet](#)
- Rigado Toolbox: [iOS](#) and [Android](#) apps

### Nordic Documents:

Visit [infocenter.nordicsemi.com](http://infocenter.nordicsemi.com) for a comprehensive library of Nordic technical documentation.

- nRF52832-PS: [nRF52832 Product Specification](#)
- S132-SDS – [nRF52832 S132 Soft Device Specification](#)
- S212-SDS – [nRF52832 S132 Soft Device Specification](#)
- S332-SDS – [nRF52832 S132 Soft Device Specification](#)





Компания «ЭлектроПласт» предлагает заключение долгосрочных отношений при поставках импортных электронных компонентов на взаимовыгодных условиях!

Наши преимущества:

- Оперативные поставки широкого спектра электронных компонентов отечественного и импортного производства напрямую от производителей и с крупнейших мировых складов;
- Поставка более 17-ти миллионов наименований электронных компонентов;
- Поставка сложных, дефицитных, либо снятых с производства позиций;
- Оперативные сроки поставки под заказ (от 5 рабочих дней);
- Экспресс доставка в любую точку России;
- Техническая поддержка проекта, помощь в подборе аналогов, поставка прототипов;
- Система менеджмента качества сертифицирована по Международному стандарту ISO 9001;
- Лицензия ФСБ на осуществление работ с использованием сведений, составляющих государственную тайну;
- Поставка специализированных компонентов (Xilinx, Altera, Analog Devices, Intersil, Interpoint, Microsemi, Aeroflex, Peregrine, Syfer, Eurofarad, Texas Instrument, Miteq, Cobham, E2V, MA-COM, Hittite, Mini-Circuits, General Dynamics и др.);

Помимо этого, одним из направлений компании «ЭлектроПласт» является направление «Источники питания». Мы предлагаем Вам помощь Конструкторского отдела:

- Подбор оптимального решения, техническое обоснование при выборе компонента;
- Подбор аналогов;
- Консультации по применению компонента;
- Поставка образцов и прототипов;
- Техническая поддержка проекта;
- Защита от снятия компонента с производства.



#### Как с нами связаться

**Телефон:** 8 (812) 309 58 32 (многоканальный)

**Факс:** 8 (812) 320-02-42

**Электронная почта:** [org@eplast1.ru](mailto:org@eplast1.ru)

**Адрес:** 198099, г. Санкт-Петербург, ул. Калинина, дом 2, корпус 4, литера А.