

To our customers,

---

## Old Company Name in Catalogs and Other Documents

---

On April 1<sup>st</sup>, 2010, NEC Electronics Corporation merged with Renesas Technology Corporation, and Renesas Electronics Corporation took over all the business of both companies. Therefore, although the old company name remains in this document, it is a valid Renesas Electronics document. We appreciate your understanding.

Renesas Electronics website: <http://www.renesas.com>

April 1<sup>st</sup>, 2010  
Renesas Electronics Corporation

Issued by: Renesas Electronics Corporation (<http://www.renesas.com>)

Send any inquiries to <http://www.renesas.com/inquiry>.

## Notice

1. All information included in this document is current as of the date this document is issued. Such information, however, is subject to change without any prior notice. Before purchasing or using any Renesas Electronics products listed herein, please confirm the latest product information with a Renesas Electronics sales office. Also, please pay regular and careful attention to additional and different information to be disclosed by Renesas Electronics such as that disclosed through our website.
2. Renesas Electronics does not assume any liability for infringement of patents, copyrights, or other intellectual property rights of third parties by or arising from the use of Renesas Electronics products or technical information described in this document. No license, express, implied or otherwise, is granted hereby under any patents, copyrights or other intellectual property rights of Renesas Electronics or others.
3. You should not alter, modify, copy, or otherwise misappropriate any Renesas Electronics product, whether in whole or in part.
4. Descriptions of circuits, software and other related information in this document are provided only to illustrate the operation of semiconductor products and application examples. You are fully responsible for the incorporation of these circuits, software, and information in the design of your equipment. Renesas Electronics assumes no responsibility for any losses incurred by you or third parties arising from the use of these circuits, software, or information.
5. When exporting the products or technology described in this document, you should comply with the applicable export control laws and regulations and follow the procedures required by such laws and regulations. You should not use Renesas Electronics products or the technology described in this document for any purpose relating to military applications or use by the military, including but not limited to the development of weapons of mass destruction. Renesas Electronics products and technology may not be used for or incorporated into any products or systems whose manufacture, use, or sale is prohibited under any applicable domestic or foreign laws or regulations.
6. Renesas Electronics has used reasonable care in preparing the information included in this document, but Renesas Electronics does not warrant that such information is error free. Renesas Electronics assumes no liability whatsoever for any damages incurred by you resulting from errors in or omissions from the information included herein.
7. Renesas Electronics products are classified according to the following three quality grades: “Standard”, “High Quality”, and “Specific”. The recommended applications for each Renesas Electronics product depends on the product’s quality grade, as indicated below. You must check the quality grade of each Renesas Electronics product before using it in a particular application. You may not use any Renesas Electronics product for any application categorized as “Specific” without the prior written consent of Renesas Electronics. Further, you may not use any Renesas Electronics product for any application for which it is not intended without the prior written consent of Renesas Electronics. Renesas Electronics shall not be in any way liable for any damages or losses incurred by you or third parties arising from the use of any Renesas Electronics product for an application categorized as “Specific” or for which the product is not intended where you have failed to obtain the prior written consent of Renesas Electronics. The quality grade of each Renesas Electronics product is “Standard” unless otherwise expressly specified in a Renesas Electronics data sheets or data books, etc.
  - “Standard”: Computers; office equipment; communications equipment; test and measurement equipment; audio and visual equipment; home electronic appliances; machine tools; personal electronic equipment; and industrial robots.
  - “High Quality”: Transportation equipment (automobiles, trains, ships, etc.); traffic control systems; anti-disaster systems; anti-crime systems; safety equipment; and medical equipment not specifically designed for life support.
  - “Specific”: Aircraft; aerospace equipment; submersible repeaters; nuclear reactor control systems; medical equipment or systems for life support (e.g. artificial life support devices or systems), surgical implantations, or healthcare intervention (e.g. excision, etc.), and any other applications or purposes that pose a direct threat to human life.
8. You should use the Renesas Electronics products described in this document within the range specified by Renesas Electronics, especially with respect to the maximum rating, operating supply voltage range, movement power voltage range, heat radiation characteristics, installation and other product characteristics. Renesas Electronics shall have no liability for malfunctions or damages arising out of the use of Renesas Electronics products beyond such specified ranges.
9. Although Renesas Electronics endeavors to improve the quality and reliability of its products, semiconductor products have specific characteristics such as the occurrence of failure at a certain rate and malfunctions under certain use conditions. Further, Renesas Electronics products are not subject to radiation resistance design. Please be sure to implement safety measures to guard them against the possibility of physical injury, and injury or damage caused by fire in the event of the failure of a Renesas Electronics product, such as safety design for hardware and software including but not limited to redundancy, fire control and malfunction prevention, appropriate treatment for aging degradation or any other appropriate measures. Because the evaluation of microcomputer software alone is very difficult, please evaluate the safety of the final products or system manufactured by you.
10. Please contact a Renesas Electronics sales office for details as to environmental matters such as the environmental compatibility of each Renesas Electronics product. Please use Renesas Electronics products in compliance with all applicable laws and regulations that regulate the inclusion or use of controlled substances, including without limitation, the EU RoHS Directive. Renesas Electronics assumes no liability for damages or losses occurring as a result of your noncompliance with applicable laws and regulations.
11. This document may not be reproduced or duplicated, in any form, in whole or in part, without prior written consent of Renesas Electronics.
12. Please contact a Renesas Electronics sales office if you have any questions regarding the information contained in this document or Renesas Electronics products, or if you have any other inquiries.

(Note 1) “Renesas Electronics” as used in this document means Renesas Electronics Corporation and also includes its majority-owned subsidiaries.

(Note 2) “Renesas Electronics product(s)” means any product developed or manufactured by or for Renesas Electronics.

## 1. Overview

This MCU is built using the high-performance silicon gate CMOS process using the R8C/Tiny Series CPU core and is packaged in a 20-pin plastic molded LSSOP. This MCU operates using sophisticated instructions featuring a high level of instruction efficiency. With 1 Mbyte of address space, it is capable of executing instructions at high speed.

Furthermore, the data flash ROM (1KB × 2blocks) is embedded in the R8C/17 group.

The difference between the R8C/16 and R8C/17 groups is only the existence of the data flash ROM. Their peripheral functions are the same.

### 1.1 Applications

Electric household appliance, office equipment, housing equipment (sensor, security), general industrial equipment, audio, etc.

## 1.2 Performance Overview

Table 1.1 lists the Performance Outline of the R8C/16 Group and Table 1.2 lists the Performance Outline of the R8C/17 Group.

**Table 1.1 Performance Outline of the R8C/16 Group**

Item		Performance
CPU	Number of Basic Instructions	89 instructions
	Minimum Instruction Execution Time	50ns(f(XIN)=20MHz, VCC=3.0 to 5.5V) 100ns(f(XIN)=10MHz, VCC=2.7 to 5.5V)
	Operating Mode	Single-chip
	Address Space	1 Mbyte
	Memory Capacity	See <b>Table 1.3 R8C/16 Group Product Information</b>
Peripheral Function	Port	I/O port : 13 pins (including LED drive port), Input : 2 pins
	LED Drive Port	I/O port: 4 pins
	Timer	Timer X: 8 bits × 1 channel, Timer Z: 8 bits × 1 channel (Each timer equipped with 8-bit prescaler) Timer C: 16 bits × 1 channel (Circuits of input capture and output compare)
	Serial Interface	1 channel Clock synchronous serial I/O, UART
	I <sup>2</sup> C bus Interface (IIC) <sup>(1)</sup>	1 channel
	A/D Converter	10-bit A/D converter: 1 circuit, 4 channels
	Watchdog Timer	15 bits × 1 channel (with prescaler) Reset start selectable, Count source protection mode
	Interrupt	Internal: 9 factors, External: 4 factors, Software: 4 factors Priority level: 7 levels
	Clock Generation Circuit	2 circuits Main clock oscillation circuit (Equipped with a built-in feedback resistor) On-chip oscillator (high speed, low speed) Equipped with frequency adjustment function on high-speed on-chip oscillator
	Oscillation Stop Detection Function	Main clock oscillation stop detection function
	Voltage Detection Circuit	Included
	Power-on Reset Circuit	Included
Electric Characteristics	Supply Voltage	VCC=3.0 to 5.5V (f(XIN)=20MHz) VCC=2.7 to 5.5V (f(XIN)=10MHz)
	Power Consumption	Typ. 9mA (VCC=5.0V, f(XIN)=20MHz) Typ. 5mA (VCC=3.0V, f(XIN)=10MHz) Typ. 35μA (VCC=3.0V, wait mode, peripheral clock off) Typ. 0.7μA (VCC=3.0V, stop mode)
Flash Memory	Program/Erase Supply Voltage	VCC=2.7 to 5.5V
	Program/Erase Endurance	100 times
Operating Ambient Temperature	-20 to 85°C -40 to 85°C (D Version)	
Package	20-pin plastic mold LSSOP	

**NOTES:**

1. I<sup>2</sup>C bus is a trademark of Koninklijke Philips Electronics N. V.

**Table 1.2 Performance Outline of the R8C/17 Group**

Item		Performance
CPU	Number of Basic Instructions	89 instructions
	Minimum Instruction Execution Time	50ns(f(XIN)=20MHz, VCC=3.0 to 5.5V) 100ns(f(XIN)=10MHz, VCC=2.7 to 5.5V)
	Operating Mode	Single-chip
	Address Space	1 Mbyte
	Memory Capacity	See <b>Table 1.4 R8C/17 Group Product Information</b>
Peripheral Function	Port	I/O : 13 pins (including LED drive port), Input : 2 pin
	LED drive port	I/O port: 4 pins
	Timer	Timer X: 8 bits × 1 channel, Timer Z: 8 bits × 1 channel (Each timer equipped with 8-bit prescaler) Timer C: 16 bits × 1 channel (Circuits of input capture and output compare)
	Serial Interface	1 channel Clock synchronous serial I/O, UART
	I <sup>2</sup> C bus Interface (IIC) <sup>(1)</sup>	1 channel
	A/D Converter	10-bit A/D converter: 1 circuit, 4 channels
	Watchdog Timer	15 bits × 1 channel (with prescaler) Reset start selectable, Count source protection mode
	Interrupt	Internal: 9 factors, External: 4 factors, Software: 4 factors Priority level: 7 levels
	Clock Generation Circuit	2 circuits Main clock generation circuit (Equipped with a built-in feedback resistor) On-chip oscillator (high speed, low speed) Equipped with frequency adjustment function on high-speed on-chip oscillator
	Oscillation Stop Detection Function	Main clock oscillation stop detection function
	Voltage Detection Circuit	Included
Power-on Reset Circuit	Included	
Electric Characteristics	Supply Voltage	VCC=3.0 to 5.5V (f(XIN)=20MHz) VCC=2.7 to 5.5V (f(XIN)=10MHz)
	Power Consumption	Typ. 9mA (VCC = 5.0V, f(XIN) = 20MHz) Typ. 5mA (VCC = 3.0V, f(XIN) = 10MHz) Typ. 35μA (VCC = 3.0V, wait mode, peripheral clock off) Typ. 0.7μA (VCC = 3.0V, stop mode)
Flash Memory	Program/Erase Supply Voltage	VCC=2.7 to 5.5V
	Program and Erase Endurance	10,000 times (Data flash) 1,000 times (Program ROM)
Operating Ambient Temperature	-20 to 85°C -40 to 85°C (D Version)	
Package	20-pin plastic mold LSSOP	

## NOTES:

1. I<sup>2</sup>C bus is a trademark of Koninklijke Philips Electronics N. V.

### 1.3 Block Diagram

Figure 1.1 shows a Block Diagram.

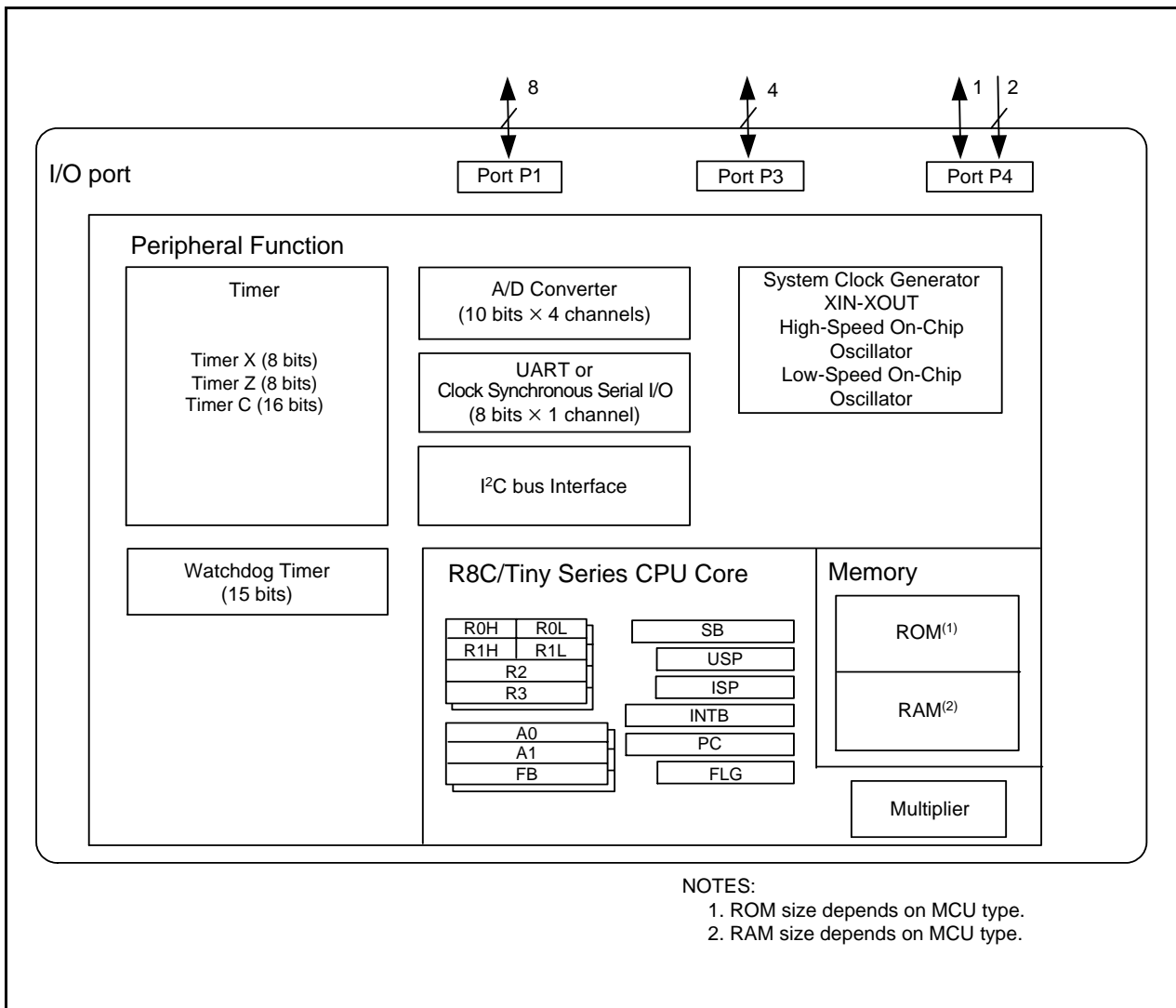

Figure 1.1 Block Diagram

### 1.4 Product Information

Table 1.3 lists the Product Information of R8C/16 Group and Table 1.4 lists the Product Information of R8C/17 Group.

**Table 1.3 Product Information of R8C/16 Group As of Jan 2006**

Type No.	ROM Capacity	RAM Capacity	Package Type	Remarks
R5F21162SP	8 Kbytes	512 bytes	PLSP0020JB-A	Flash Memory Version
R5F21163SP	12 Kbytes	768 bytes	PLSP0020JB-A	
R5F21164SP	16 Kbytes	1 Kbyte	PLSP0020JB-A	
R5F21162DSP	8 Kbytes	512 bytes	PLSP0020JB-A	D Version
R5F21163DSP	12 Kbytes	768 bytes	PLSP0020JB-A	
R5F21164DSP	16 Kbytes	1 Kbyte	PLSP0020JB-A	

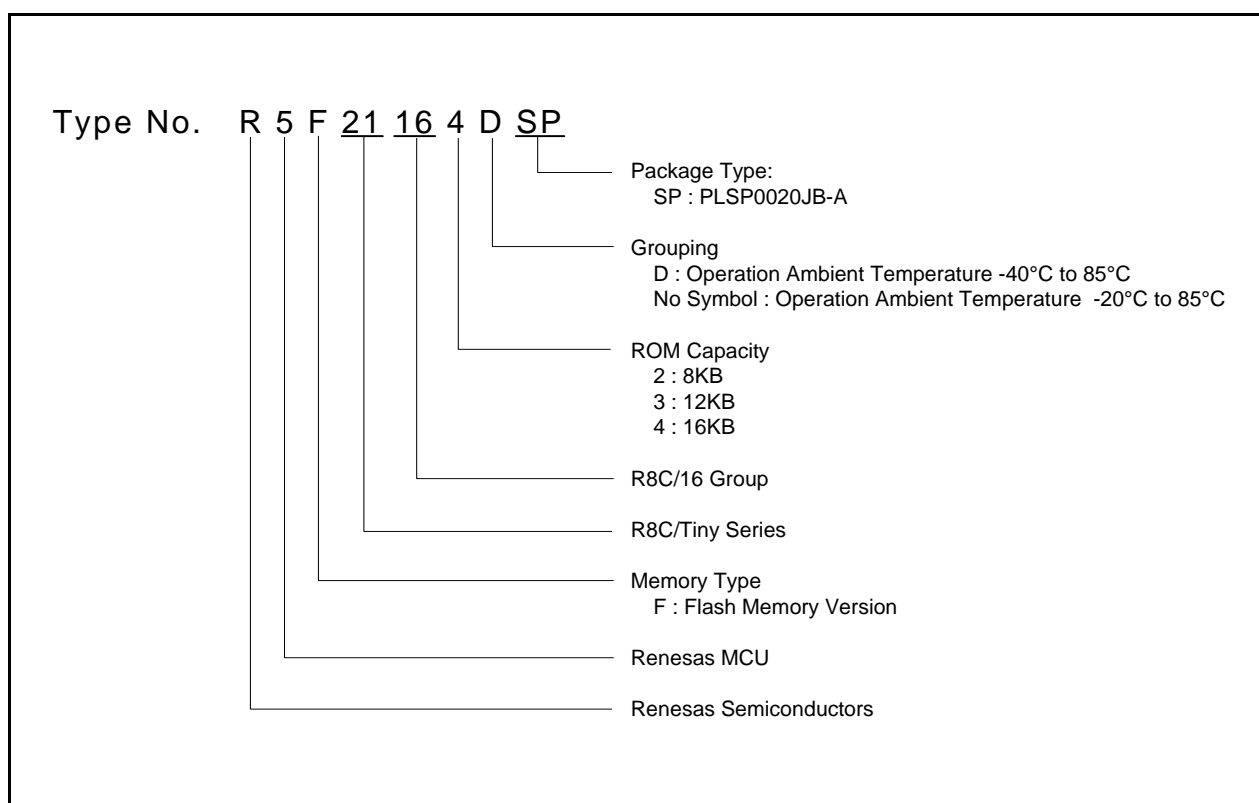

**Figure 1.2 Part Number, Memory Size and Package of R8C/16 Group**

Table 1.4 Product Information of R8C/17 Group

As of Jan 2006

Type No.	ROM Capacity		RAM Capacity	Package Type	Remarks
	Program ROM	Data flash			
R5F21172SP	8 Kbytes	1 Kbyte × 2	512 bytes	PLSP0020JB-A	Flash Memory Version
R5F21173SP	12 Kbytes	1 Kbyte × 2	768 bytes	PLSP0020JB-A	
R5F21174SP	16 Kbytes	1 Kbyte × 2	1 Kbyte	PLSP0020JB-A	
R5F21172DSP	8 Kbytes	1 Kbyte × 2	512 bytes	PLSP0020JB-A	D Version
R5F21173DSP	12 Kbytes	1 Kbyte × 2	768 bytes	PLSP0020JB-A	
R5F21174DSP	16 Kbytes	1 Kbyte × 2	1 Kbyte	PLSP0020JB-A	

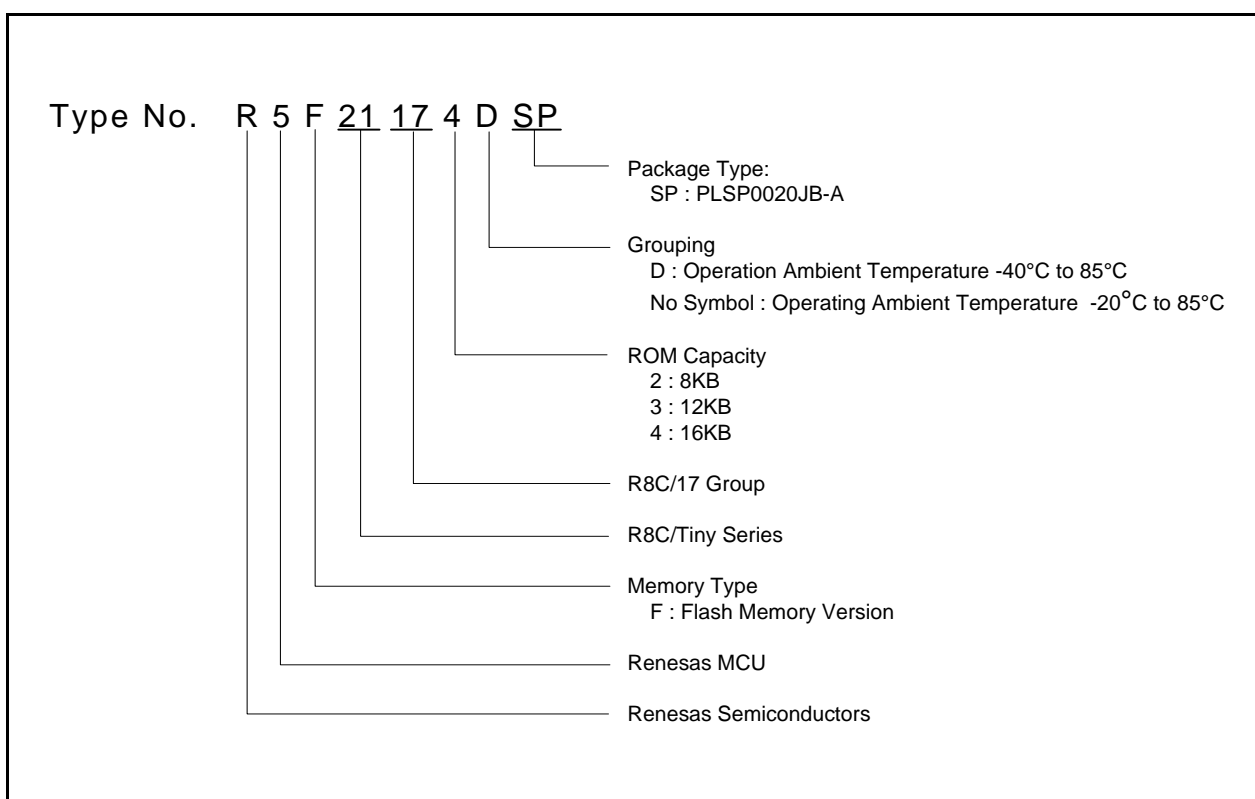

Figure 1.3 Part Number, Memory Size and Package of R8C/17 Group



### 1.5 Pin Assignments

Figure 1.4 shows the PLSP0020JB-A Package Pin Assignment (top view).

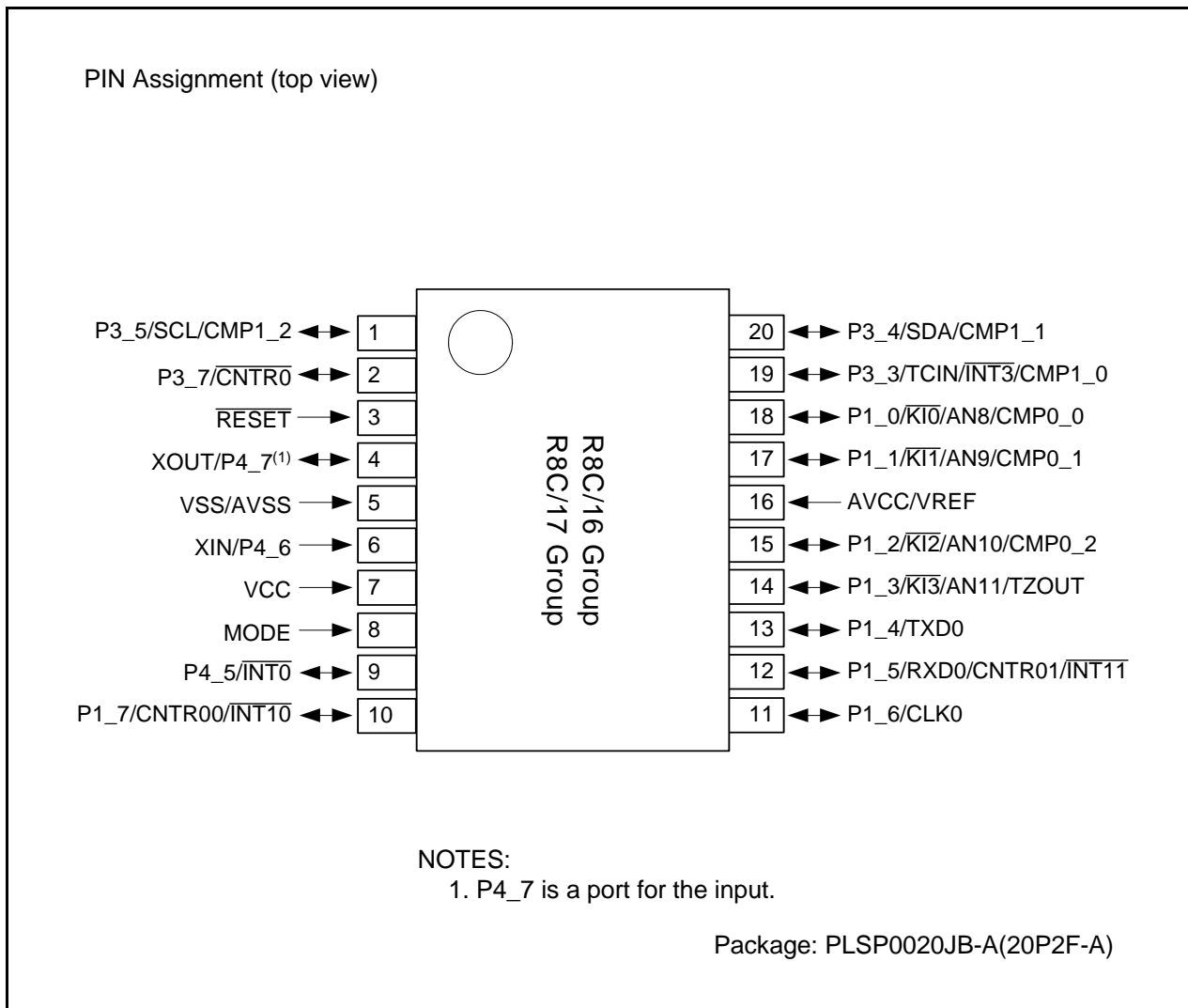

Figure 1.4 PLSP0020JB-A Package Pin Assignment (top view)

## 1.6 Pin Description

Table 1.5 lists the Pin Description and Table 1.6 lists the Pin Name Information by Pin Number.

**Table 1.5 Pin Description**

Function	Pin Name	I/O Type	Description
Power Supply Input	VCC VSS	I	Apply 2.7V to 5.5V to the VCC pin. Apply 0V to the VSS pin
Analog Power Supply Input	AVCC AVSS	I	Power supply input pins to A/D converter. Connect AVCC to VCC. Apply 0V to AVSS. Connect a capacitor between AVCC and AVSS.
Reset Input	$\overline{\text{RESET}}$	I	Input "L" on this pin resets the MCU
MODE	MODE	I	Connect this pin to VCC via a resistor
Main Clock Input	XIN	I	These pins are provided for the main clock generation circuit I/O. Connect a ceramic resonator or a crystal oscillator between the XIN and XOUT pins. To use an externally derived clock, input it to the XIN pin and leave the XOUT pin open.
Main Clock Output	XOUT	O	
$\overline{\text{INT}}$ Interrupt	$\overline{\text{INT0}}$ , $\overline{\text{INT1}}$ , $\overline{\text{INT3}}$	I	INT interrupt input pins
Key Input Interrupt	KI0 to KI3	I	Key input interrupt input pins
Timer X	CNTR0	I/O	Timer X I/O pin
	$\overline{\text{CNTR0}}$	O	Timer X output pin
Timer Z	TZOUT	O	Timer Z output pin
Timer C	TCIN	I	Timer C input pin
	CMP0_0 to CMP0_2, CMP1_0 to CMP1_2	O	Timer C output pins
Serial Interface	CLK0	I/O	Transfer clock I/O pin
	RXD0	I	Serial data input pin
	TXD0	O	Serial data output pin
I <sup>2</sup> C bus Interface (IIC)	SCL	I/O	Clock I/O pin
	SDA	I/O	Data I/O pin
Reference Voltage Input	VREF	I	Reference voltage input pin to A/D converter Connect VREF to VCC
A/D Converter	AN8 to AN11	I	Analog input pins to A/D converter
I/O Port	P1_0 to P1_7, P3_3 to P3_5, P3_7, P4_5	I/O	These are CMOS I/O ports. Each port contains an I/O select direction register, allowing each pin in that port to be directed for input or output individually. Any port set to input can select whether to use a pull-up resistor or not by program. P1_0 to P1_3 also function as LED drive ports.
Input Port	P4_6, P4_7	I	Port for input-only

I: Input    O: Output    I/O: Input and output

**Table 1.6 Pin Name Information by Pin Number**

Pin Number	Control Pin	Port	I/O Pin of Peripheral Functions				
			Interrupt	Timer	Serial Interface	I <sup>2</sup> C bus Interface	A/D Converter
1		P3_5		CMP1_2		SCL	
2		P3_7		$\overline{\text{CNTR0}}$			
3	$\overline{\text{RESET}}$						
4	XOUT	P4_7					
5	VSS/AVSS						
6	XIN	P4_6					
7	VCC						
8	MODE						
9		P4_5	$\overline{\text{INT0}}$				
10		P1_7	$\overline{\text{INT10}}$	CNTR00			
11		P1_6			CLK0		
12		P1_5	$\overline{\text{INT11}}$	CNTR01	RXD0		
13		P1_4			TXD0		
14		P1_3	$\overline{\text{KI3}}$	TZOUT			AN11
15		P1_2	$\overline{\text{KI2}}$	CMP0_2			AN10
16	AVCC/VREF						
17		P1_1	$\overline{\text{KI1}}$	CMP0_1			AN9
18		P1_0	$\overline{\text{KI0}}$	CMP0_0			AN8
19		P3_3	$\overline{\text{INT3}}$	TCIN/CMP1_0			
20		P3_4		CMP1_1		SDA	

## 2. Central Processing Unit (CPU)

Figure 2.1 shows the CPU Register. The CPU contains 13 registers. Of these, R0, R1, R2, R3, A0, A1 and FB comprise a register bank. Two sets of register banks are provided.

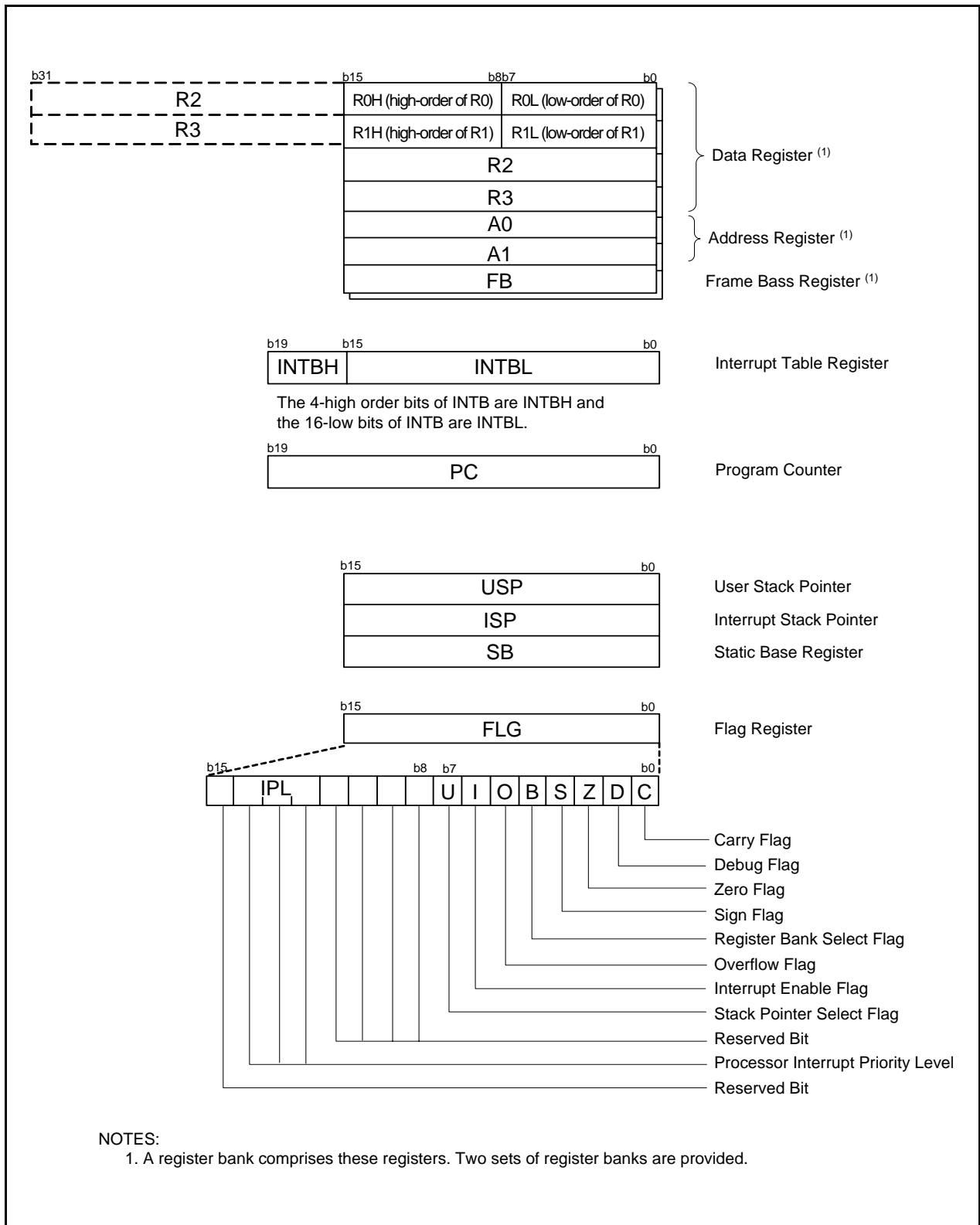

Figure 2.1 CPU Register

## 2.1 Data Registers (R0, R1, R2 and R3)

R0 is a 16-bit register for transfer, arithmetic and logic operations. The same applies to R1 to R3. The R0 can be split into high-order bit (R0H) and low-order bit (R0L) to be used separately as 8-bit data registers. The same applies to R1H and R1L as R0H and R0L. R2 can be combined with R0 to be used as a 32-bit data register (R2R0). The same applies to R3R1 as R2R0.

## 2.2 Address Registers (A0 and A1)

A0 is a 16-bit register for address register indirect addressing and address register relative addressing. They also are used for transfer, arithmetic and logic operations. The same applies to A1 as A0. A0 can be combined with A0 to be used as a 32-bit address register (A1A0).

## 2.3 Frame Base Register (FB)

FB is a 16-bit register for FB relative addressing.

## 2.4 Interrupt Table Register (INTB)

INTB is a 20-bit register indicates the start address of an interrupt vector table.

## 2.5 Program Counter (PC)

PC, 20 bits wide, indicates the address of an instruction to be executed.

## 2.6 User Stack Pointer (USP) and Interrupt Stack Pointer (ISP)

The stack pointer (SP), USP and ISP, are 16 bits wide each. The U flag of FLG is used to switch between USP and ISP.

## 2.7 Static Base Register (SB)

SB is a 16-bit register for SB relative addressing.

## 2.8 Flag Register (FLG)

FLG is a 11-bit register indicating the CPU state.

### 2.8.1 Carry Flag (C)

The C flag retains a carry, borrow, or shift-out bit that has occurred in the arithmetic logic unit.

### 2.8.2 Debug Flag (D)

The D flag is for debug only. Set to "0".

### 2.8.3 Zero Flag (Z)

The Z flag is set to "1" when an arithmetic operation resulted in 0; otherwise, "0".

### 2.8.4 Sign Flag (S)

The S flag is set to "1" when an arithmetic operation resulted in a negative value; otherwise, "0".

### 2.8.5 Register Bank Select Flag (B)

The register bank 0 is selected when the B flag is "0". The register bank 1 is selected when this flag is set to "1".

### 2.8.6 Overflow Flag (O)

The O flag is set to "1" when the operation resulted in an overflow; otherwise, "0".

### **2.8.7 Interrupt Enable Flag (I)**

The I flag enables a maskable interrupt.

An interrupt is disabled when the I flag is set to "0", and are enabled when the I flag is set to "1". The I flag is set to "0" when an interrupt request is acknowledged.

### **2.8.8 Stack Pointer Select Flag (U)**

ISP is selected when the U flag is set to "0", USP is selected when the U flag is set to "1".

The U flag is set to "0" when a hardware interrupt request is acknowledged or the INT instruction of software interrupt numbers 0 to 31 is executed.

### **2.8.9 Processor Interrupt Priority Level (IPL)**

IPL, 3 bits wide, assigns processor interrupt priority levels from level 0 to level 7.

If a requested interrupt has greater priority than IPL, the interrupt is enabled.

### **2.8.10 Reserved Bit**

When write to this bit, set to "0". When read, its content is indeterminate.

### 3. Memory

#### 3.1 R8C/16 Group

Figure 3.1 is a Memory Map of the R8C/16 group. The R8C/16 group provides 1-Mbyte address space from addresses 00000h to FFFFFh.

The internal ROM is allocated lower addresses beginning with address 0FFFFh. For example, a 16-Kbyte internal ROM is allocated addresses 0C000h to 0FFFFh.

The fixed interrupt vector table is allocated addresses 0FFDCh to 0FFFFh. They store the starting address of each interrupt routine.

The internal RAM is allocated higher addresses beginning with address 00400h. For example, a 1-Kbyte internal RAM is allocated addresses 00400h to 007FFh. The internal RAM is used not only for storing data but for calling subroutines and stacks when interrupt request is acknowledged.

Special function registers (SFR) are allocated addresses 00000h to 002FFh. The peripheral function control registers are allocated them. All addresses, which have nothing allocated within the SFR, are reserved area and cannot be accessed by users.

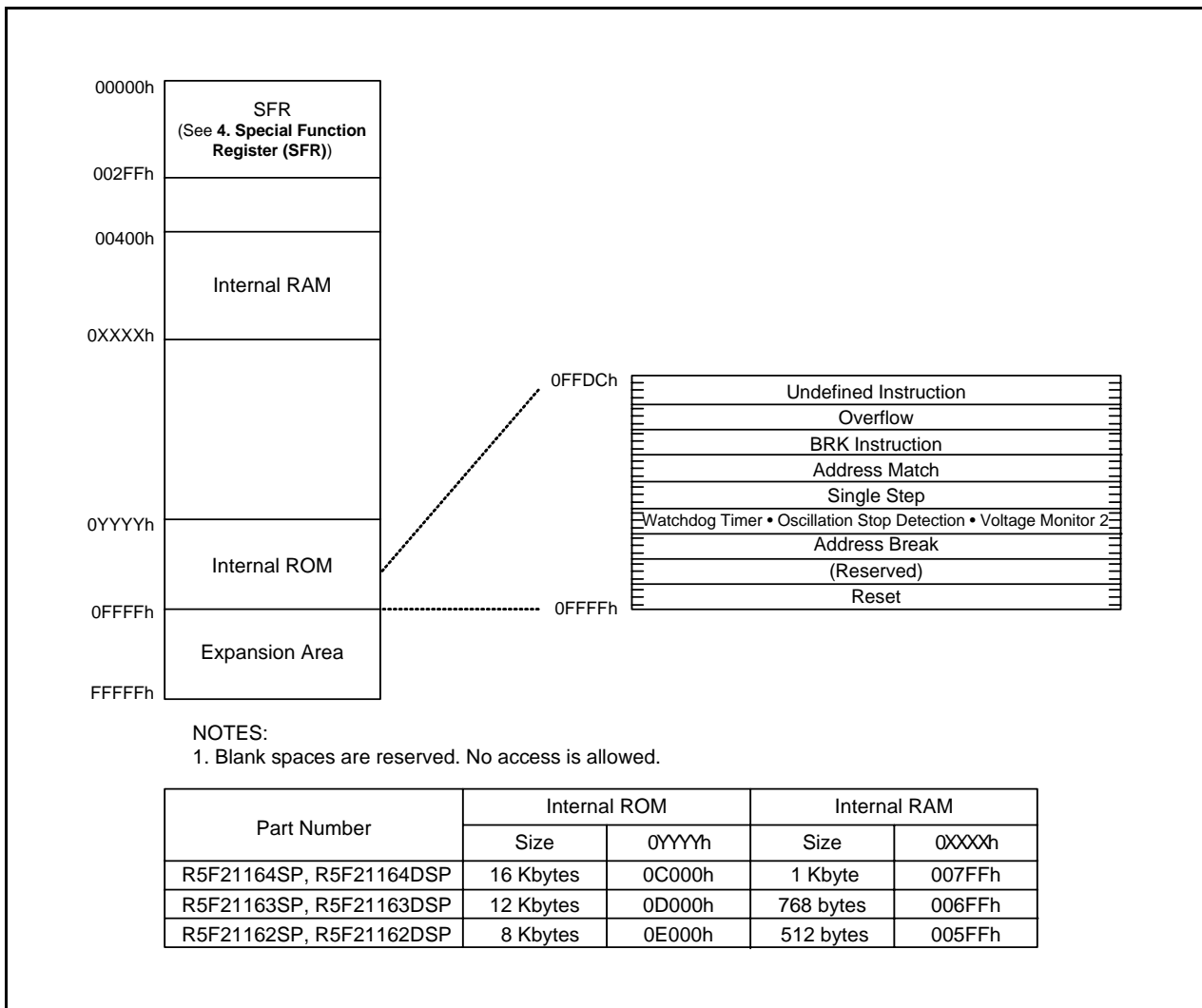

Figure 3.1 Memory Map of R8C/16 Group

### 3.2 R8C/17 Group

Figure 3.2 is a memory map of the R8C/17 group. The R8C/17 group provides 1-Mbyte address space from addresses 00000h to FFFFFh.

The internal ROM (program ROM) is allocated lower addresses beginning with address 0FFFFh. For example, a 16-Kbyte internal ROM is allocated addresses 0C000h to 0FFFFh.

The fixed interrupt vector table is allocated addresses 0FFDCh to 0FFFFh. They store the starting address of each interrupt routine.

The internal ROM (data flash) is allocated addresses 02400h to 02BFFh.

The internal RAM is allocated higher addresses beginning with address 00400h. For example, a 1-Kbyte internal RAM is allocated addresses 00400h to 007FFh. The internal RAM is used not only for storing data but for calling subroutines and stacks when interrupt request is acknowledged.

Special function registers (SFR) are allocated addresses 00000h to 002FFh. The peripheral function control registers are allocated them. All addresses, which have nothing allocated within the SFR, are reserved area and cannot be accessed by users.

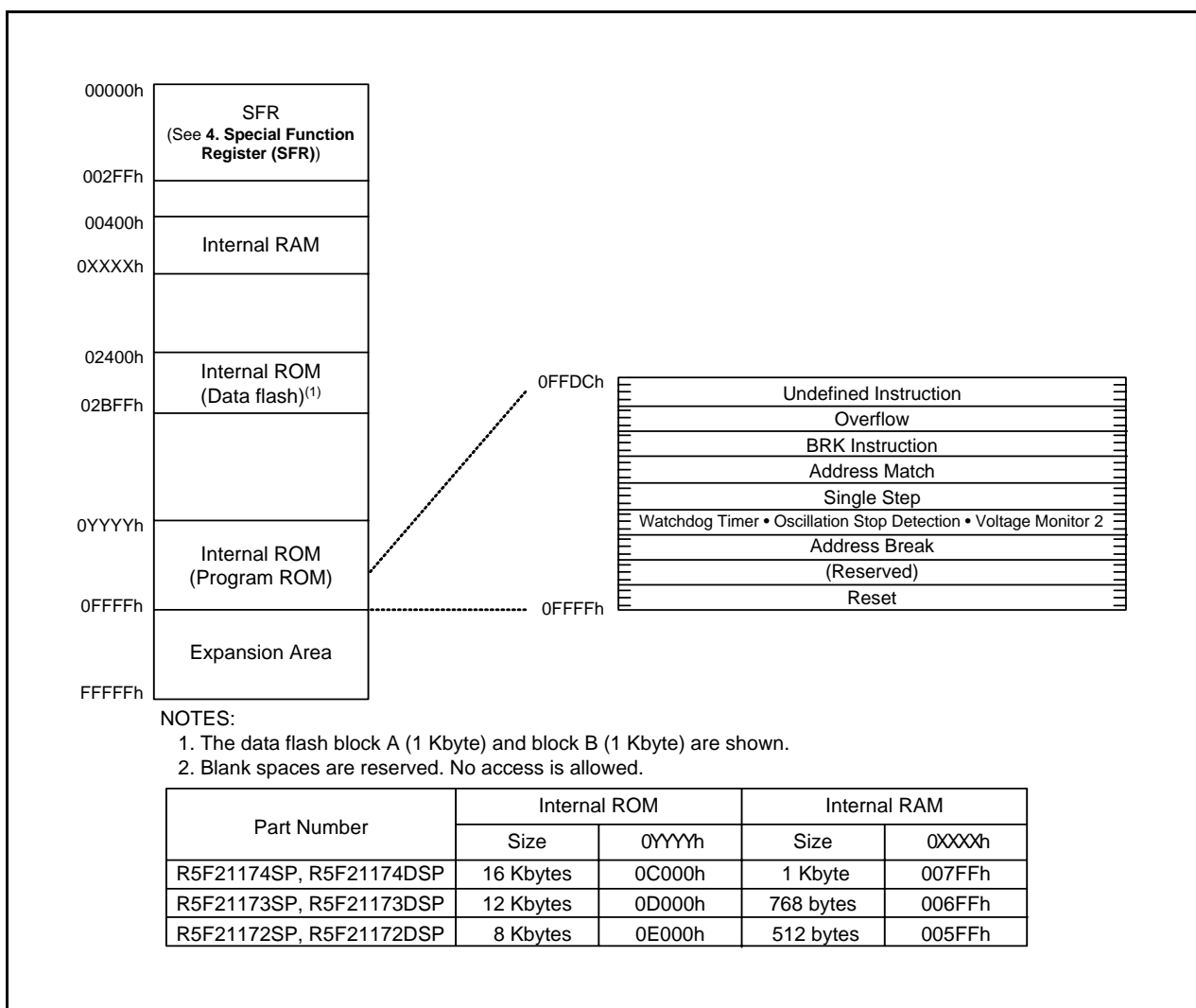

Figure 3.2 Memory Map of R8C/17 Group



## 4. Special Function Register (SFR)

SFR (Special Function Register) is the control register of peripheral functions. Tables 4.1 to 4.4 list the SFR information.

**Table 4.1 SFR Information(1)(1)**

Address	Register	Symbol	After Reset
0000h			
0001h			
0002h			
0003h			
0004h	Processor Mode Register 0	PM0	00h
0005h	Processor Mode Register 1	PM1	00h
0006h	System Clock Control Register 0	CM0	01101000b
0007h	System Clock Control Register 1	CM1	00100000b
0008h			
0009h	Address Match Interrupt Enable Register	AIER	00h
000Ah	Protect Register	PRCR	00h
000Bh			
000Ch	Oscillation Stop Detection register	OCD	00000100b
000Dh	Watchdog Timer Reset Register	WDTR	XXh
000Eh	Watchdog Timer Start Register	WDTS	XXh
000Fh	Watchdog Timer Control Register	WDC	00011111b
0010h	Address Match Interrupt Register 0	RMAD0	00h
0011h			00h
0012h			X0h
0013h			
0014h	Address Match Interrupt Register 1	RMAD1	00h
0015h			00h
0016h			X0h
0017h			
0018h			
0019h			
001Ah			
001Bh			
001Ch	Count Source Protection Mode Register	CSPR	00h
001Dh			
001Eh	INT0 Input Filter Select Register	INT0F	00h
001Fh			
0020h	High-Speed On-Chip Oscillator Control Register 0	HRA0	00h
0021h	High-Speed On-Chip Oscillator Control Register 1	HRA1	When shipping
0022h	High-Speed On-Chip Oscillator Control Register 2	HRA2	00h
0023h			
0024h			
0025h			
0026h			
0027h			
0028h			
0029h			
002Ah			
002Bh			
002Ch			
002Dh			
002Eh			
002Fh			
0030h			
0031h	Voltage Detection Register 1 <sup>(2)</sup>	VCA1	00001000b
0032h	Voltage Detection Register 2 <sup>(2)</sup>	VCA2	00h <sup>(3)</sup> 01000000b <sup>(4)</sup>
0033h			
0034h			
0035h			
0036h	Voltage Monitor 1 Circuit Control Register <sup>(2)</sup>	VW1C	0000X000b <sup>(3)</sup> 0100X001b <sup>(4)</sup>
0037h	Voltage Monitor 2 Circuit Control Register <sup>(5)</sup>	VW2C	00h
0038h			
0039h			
003Ah			
003Bh			
003Ch			
003Dh			
003Eh			
003Fh			

X: Undefined

NOTES:

- Blank spaces are reserved. No access is allowed.
- Software reset, the watchdog timer reset or the voltage monitor 2 reset does not affect this register.
- Owing to Hardware reset.
- Owing to Power-on reset or the voltage monitor 1 reset.
- Software reset, the watchdog timer reset or the voltage monitor 2 reset does not affect the b2 and b3.

**Table 4.2 SFR Information(2)(1)**

Address	Register	Symbol	After reset
0040h			
0041h			
0042h			
0043h			
0044h			
0045h			
0046h			
0047h			
0048h			
0049h			
004Ah			
004Bh			
004Ch			
004Dh	Key Input Interrupt Control Register	KUPIC	XXXXX000b
004Eh	A/D Conversion Interrupt Control Register	ADIC	XXXXX000b
004Fh	IIC Interrupt Control Register	IIC2AIC	XXXXX000b
0050h	Compare 1 Interrupt Control Register	CMP1IC	XXXXX000b
0051h	UART0 Transmit Interrupt Control Register	S0TIC	XXXXX000b
0052h	UART0 Receive Interrupt Control Register	S0RIC	XXXXX000b
0053h			
0054h			
0055h			
0056h	Timer X Interrupt Control Register	TXIC	XXXXX000b
0057h			
0058h	Timer Z Interrupt Control Register	TZIC	XXXXX000b
0059h	INT1 Interrupt Control Register	INT1IC	XXXXX000b
005Ah	INT3 Interrupt Control Register	INT3IC	XXXXX000b
005Bh	Timer C Interrupt Control Register	TCIC	XXXXX000b
005Ch	Compare 0 Interrupt Control Register	CMP0IC	XXXXX000b
005Dh	INT0 Interrupt Control Register	INT0IC	XX00X000b
005Eh			
005Fh			
0060h			
0061h			
0062h			
0063h			
0064h			
0065h			
0066h			
0067h			
0068h			
0069h			
006Ah			
006Bh			
006Ch			
006Dh			
006Eh			
006Fh			
0070h			
0071h			
0072h			
0073h			
0074h			
0075h			
0076h			
0077h			
0078h			
0079h			
007Ah			
007Bh			
007Ch			
007Dh			
007Eh			
007Fh			

X: Undefined

NOTES:

- Blank spaces are reserved. No access is allowed.

**Table 4.3 SFR Information(3)(1)**

Address	Register	Symbol	After Reset
0080h	Timer Z Mode Register	TZMR	00h
0081h			
0082h			
0083h			
0084h	Timer Z Waveform Output Control Register	PUM	00h
0085h	Prescaler Z Register	PREZ	FFh
0086h	Timer Z Secondary Register	TZSC	FFh
0087h	Timer Z Primary Register	TZPR	FFh
0088h			
0089h			
008Ah	Timer Z Output Control Register	TZOC	00h
008Bh	Timer X Mode Register	TXMR	00h
008Ch	Prescaler X Register	PREX	FFh
008Dh	Timer X Register	TX	FFh
008Eh	Timer Count Source Setting Register	TCSS	00h
008Fh			
0090h	Timer C Register	TC	00h
0091h			00h
0092h			
0093h			
0094h			
0095h			
0096h	External Input Enable Register	INTEN	00h
0097h			
0098h	Key Input Enable Register	KIEN	00h
0099h			
009Ah	Timer C Control Register 0	TCC0	00h
009Bh	Timer C Control Register 1	TCC1	00h
009Ch	Capture, Compare 0 Register	TM0	00h
009Dh			00h <sup>(2)</sup>
009Eh	Compare 1 Register	TM1	FFh
009Fh			FFh
00A0h	UART0 Transmit/Receive Mode Register	U0MR	00h
00A1h	UART0 Bit Rate Register	U0BRG	XXh
00A2h	UART0 Transmit Buffer Register	U0TB	XXh
00A3h			XXh
00A4h	UART0 Transmit/Receive Control Register 0	U0C0	00001000b
00A5h	UART0 Transmit/Receive Control Register 1	U0C1	00000010b
00A6h	UART0 Receive Buffer Register	U0RB	XXh
00A7h			XXh
00A8h			
00A9h			
00AAh			
00ABh			
00ACh			
00ADh			
00AEh			
00AFh			
00B0h	UART Transmit/Receive Control Register 2	U0CON	00h
00B1h			
00B2h			
00B3h			
00B4h			
00B5h			
00B6h			
00B7h			
00B8h	IIC bus Control Register 1	ICCR1	00h
00B9h	IIC bus Control Register 2	ICCR2	7Dh
00BAh	IIC bus Mode Register	ICMR	18h
00BBh	IIC bus Interrupt Enable Register	ICIER	00h
00BCh	IIC bus Status Register	ICSR	00h
00BDh	Slave Address Register	SAR	00h
00BEh	IIC bus Transmit Data Register	ICDRT	FFh
00BFh	IIC bus Receive Data Register	ICDRR	FFh

X: Undefined

## NOTES:

- Blank spaces are reserved. No access is allowed.
- When output compare mode (the TCC13 bit in the TCC1 register = 1) is selected, the value after reset is "FFFFh".

**Table 4.4 SFR Information(4)(1)**

Address	Register	Symbol	After reset
00C0h	A/D Register	AD	XXh
00C1h			XXh
00C2h			
00C3h			
00C4h			
00C5h			
00C6h			
00C7h			
00C8h			
00C9h			
00CAh			
00CBh			
00CCh			
00CDh			
00CEh			
00CFh			
00D0h			
00D1h			
00D2h			
00D3h			
00D4h	A/D Control Register 2	ADCON2	00h
00D5h			
00D6h	A/D Control Register 0	ADCON0	00000XXb
00D7h	A/D Control Register 1	ADCON1	00h
00D8h			
00D9h			
00DAh			
00DBh			
00DCh			
00DDh			
00DEh			
00DFh			
00E0h			
00E1h	Port P1 Register	P1	XXh
00E2h			
00E3h	Port P1 Direction Register	PD1	00h
00E4h			
00E5h	Port P3 Register	P3	XXh
00E6h			
00E7h	Port P3 Direction Register	PD3	00h
00E8h	Port P4 Register	P4	XXh
00E9h			
00EAh	Port P4 Direction Register	PD4	00h
00EBh			
00ECh			
00EDh			
00EEh			
00EFh			
00F0h			
00F1h			
00F2h			
00F3h			
00F4h			
00F5h			
00F6h			
00F7h			
00F8h			
00F9h			
00FAh			
00FBh			
00FCh	Pull-Up Control Register 0	PUR0	00XX0000b
00FDh	Pull-Up Control Register 1	PUR1	XXXXXX0Xb
00FEh	Port P1 Drive Capacity Control Register	DRR	00h
00FFh	Timer C Output Control Register	TCOUT	00h
01B3h	Flash Memory Control Register 4	FMR4	01000000b
01B4h			
01B5h	Flash Memory Control Register 1	FMR1	1000000Xb
01B6h			
01B7h	Flash Memory Control Register 0	FMR0	00000001b
0FFFh	Optional Function Select Register	OFS	(2)

X: Undefined

## NOTES:

- Blank columns, 0100h to 01B2h and 01B8h to 02FFh are all reserved. No access is allowed.
- The OFS register cannot be changed by program. Use a flash programmer to write to it.

## 5. Electrical Characteristics

**Table 5.1 Absolute Maximum Ratings**

Symbol	Parameter	Condition	Rated value	Unit
V <sub>CC</sub>	Supply Voltage	V <sub>CC</sub> = AV <sub>CC</sub>	-0.3 to 6.5	V
AV <sub>CC</sub>	Analog Supply Voltage	V <sub>CC</sub> = AV <sub>CC</sub>	-0.3 to 6.5	V
V <sub>I</sub>	Input Voltage		-0.3 to V <sub>CC</sub> +0.3	V
V <sub>O</sub>	Output Voltage		-0.3 to V <sub>CC</sub> +0.3	V
P <sub>d</sub>	Power Dissipation	T <sub>opr</sub> = 25°C	300	mW
T <sub>opr</sub>	Operating Ambient Temperature		-20 to 85 / -40 to 85 (D version)	°C
T <sub>stg</sub>	Storage Temperature		-65 to 150	°C

**Table 5.2 Recommended Operating Conditions**

Symbol	Parameter		Conditions	Standard			Unit
				Min.	Typ.	Max.	
V <sub>CC</sub>	Supply Voltage			2.7	–	5.5	V
AV <sub>CC</sub>	Analog Supply Voltage			–	V <sub>CC</sub> ( <sup>3</sup> )	–	V
V <sub>SS</sub>	Supply Voltage			–	0	–	V
AV <sub>SS</sub>	Analog Supply Voltage			–	0	–	V
V <sub>IH</sub>	Input “H” Voltage			0.8V <sub>CC</sub>	–	V <sub>CC</sub>	V
V <sub>IL</sub>	Input “L” Voltage			0	–	0.2V <sub>CC</sub>	V
I <sub>OH(sum)</sub>	Peak Sum Output “H” Current	Sum of All Pins I <sub>OH</sub> (peak)		–	–	-60	mA
I <sub>OH(peak)</sub>	Peak Output “H” Current			–	–	-10	mA
I <sub>OH(avg)</sub>	Average Output “H” Current			–	–	-5	mA
I <sub>OL(sum)</sub>	Peak Sum Output “L” Currents	Sum of All Pins I <sub>OL</sub> (peak)		–	–	60	mA
I <sub>OL(peak)</sub>	Peak Output “L” Currents	Except P1_0 to P1_3		–	–	10	mA
		P1_0 to P1_3	Drive Capacity HIGH	–	–	30	mA
			Drive Capacity LOW	–	–	10	mA
I <sub>OL(avg)</sub>	Average Output “L” Current	Except P1_0 to P1_3		–	–	5	mA
		P1_0 to P1_3	Drive Capacity HIGH	–	–	15	mA
			Drive Capacity LOW	–	–	5	mA
f <sub>(XIN)</sub>	Main Clock Input Oscillation Frequency		3.0V ≤ V <sub>CC</sub> ≤ 5.5V	0	–	20	MHz
			2.7V ≤ V <sub>CC</sub> < 3.0V	0	–	10	MHz

**NOTES:**

1. V<sub>CC</sub> = AV<sub>CC</sub> = 2.7 to 5.5V at T<sub>opr</sub> = -20 to 85 °C / -40 to 85 °C, unless otherwise specified.
2. The typical values when average output current is 100ms.
3. Hold V<sub>CC</sub> = AV<sub>CC</sub>.

**Table 5.3 A/D Converter Characteristics**

Symbol	Parameter		Conditions	Standard			Unit
				Min.	Typ.	Max.	
–	Resolution		$V_{ref} = V_{CC}$	–	–	10	Bits
–	Absolute Accuracy	10-Bit Mode	$\phi_{AD} = 10\text{MHz}, V_{ref} = V_{CC} = 5.0\text{V}$	–	–	$\pm 3$	LSB
		8-Bit Mode	$\phi_{AD} = 10\text{MHz}, V_{ref} = V_{CC} = 5.0\text{V}$	–	–	$\pm 2$	LSB
		10-Bit Mode	$\phi_{AD} = 10\text{MHz}, V_{ref} = V_{CC} = 3.3\text{V}^{(3)}$	–	–	$\pm 5$	LSB
		8-Bit Mode	$\phi_{AD} = 10\text{MHz}, V_{ref} = V_{CC} = 3.3\text{V}^{(3)}$	–	–	$\pm 2$	LSB
$R_{ladder}$	Resistor Ladder		$V_{ref} = V_{CC}$	10	–	40	$k\Omega$
$t_{conv}$	Conversion Time	10-Bit Mode	$\phi_{AD} = 10\text{MHz}, V_{ref} = V_{CC} = 5.0\text{V}$	3.3	–	–	$\mu\text{s}$
		8-Bit Mode	$\phi_{AD} = 10\text{MHz}, V_{ref} = V_{CC} = 5.0\text{V}$	2.8	–	–	$\mu\text{s}$
$V_{ref}$	Reference voltage			–	$V_{CC}^{(4)}$	–	V
$V_{IA}$	Analog Input Voltage			0	–	$V_{ref}$	V
–	A/D Operating Clock Frequency <sup>(2)</sup>	Without Sample & Hold		0.25	–	10	MHz
		With Sample & Hold		1	–	10	MHz

NOTES:

1.  $V_{CC} = AV_{CC} = 2.7$  to  $5.5\text{V}$  at  $T_{opr} = -20$  to  $85\text{ }^\circ\text{C}$  /  $-40$  to  $85\text{ }^\circ\text{C}$ , unless otherwise specified.
2. If  $f_1$  exceeds  $10\text{MHz}$ , divide the  $f_1$  and hold A/D operating clock frequency ( $\phi_{AD}$ )  $10\text{MHz}$  or below.
3. If the  $AV_{CC}$  is less than  $4.2\text{V}$ , divide the  $f_1$  and hold A/D operating clock frequency ( $\phi_{AD}$ )  $f_1/2$  or below.
4. Hold  $V_{CC} = V_{ref}$

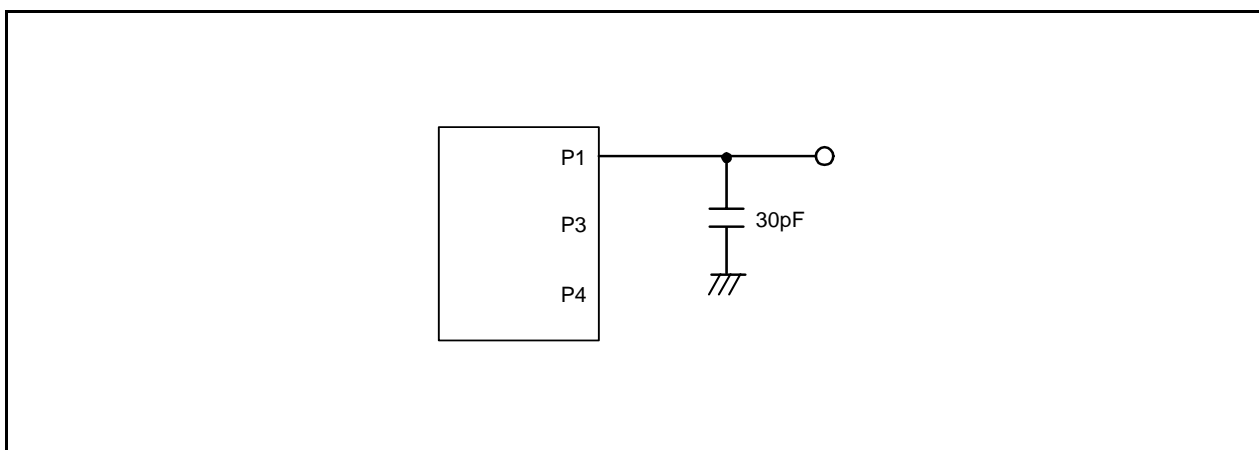

**Figure 5.1 Port P1, P3 and P4 Measurement Circuit**

**Table 5.4 Flash Memory (Program ROM) Electrical Characteristics**

Symbol	Parameter	Conditions	Standard			Unit
			Min.	Typ.	Max.	
–	Program/Erase Endurance <sup>(2)</sup>	R8C/16 Group	100 <sup>(3)</sup>	–	–	times
		R8C/17 Group	1,000 <sup>(3)</sup>	–	–	times
–	Byte Program Time	V <sub>CC</sub> = 5.0 V at T <sub>opr</sub> = 25 °C	–	50	400	μs
–	Block Erase Time	V <sub>CC</sub> = 5.0 V at T <sub>opr</sub> = 25 °C	–	0.4	9	s
t <sub>d</sub> (SR-ES)	Time Delay from Suspend Request until Erase Suspend		–	–	8	ms
–	Erase Suspend Request Interval		10	–	–	ms
–	Program, Erase Voltage		2.7	–	5.5	V
–	Read Voltage		2.7	–	5.5	V
–	Program, Erase Temperature		0	–	60	°C
–	Data Hold Time <sup>(7)</sup>	Ambient temperature = 55 °C	20	–	–	year

## NOTES:

- V<sub>CC</sub> = AV<sub>CC</sub> = 2.7 to 5.5V at T<sub>opr</sub> = 0 to 60 °C, unless otherwise specified.
- Definition of program and erase  
The program and erase endurance shows an erase endurance for every block.  
If the program and erase endurance is “n” times (n = 100, 10000), “n” times erase can be performed for every block.  
For example, if performing 1-byte write to the distinct addresses on Block A of 1Kbyte block 1,024 times and then erasing that block, program and erase endurance is counted as one time.  
However, do not perform multiple programs to the same address for one time erase.(disable overwriting).
- Endurance to guarantee all electrical characteristics after program and erase.(1 to “Min.” value can be guaranteed).
- In the case of a system to execute multiple programs, perform one erase after programming as reducing effective reprogram endurance not to leave blank area as possible such as programming write addresses in turn. If programming a set of 16 bytes, programming up to 128 sets and then erasing them one time can reduce effective reprogram endurance. Additionally, averaging erase endurance for Block A and B can reduce effective reprogram endurance more. To leave erase endurance for every block as information and determine the restricted endurance are recommended.
- If error occurs during block erase, attempt to execute the clear status register command, then the block erase command at least three times until the erase error does not occur.
- Customers desiring Program/Erase failure rate information should contact their Renesas technical support representative.
- The data hold time includes time that the power supply is off or the clock is not supplied.

**Table 5.5 Flash Memory (Data flash Block A, Block B) Electrical Characteristics**

Symbol	Parameter	Conditions	Standard			Unit
			Min.	Typ.	Max.	
–	Program/Erase Endurance <sup>(2)</sup>		10,000 <sup>(3)</sup>	–	–	times
–	Byte Program Time (Program/Erase Endurance ≤ 1,000 Times)	V <sub>CC</sub> = 5.0 V at T <sub>opr</sub> = 25 °C	–	50	400	μs
–	Byte Program Time (Program/Erase Endurance > 1,000 Times)	V <sub>CC</sub> = 5.0 V at T <sub>opr</sub> = 25 °C	–	65	–	μs
–	Block Erase Time (Program/Erase Endurance ≤ 1,000 Times)	V <sub>CC</sub> = 5.0 V at T <sub>opr</sub> = 25 °C	–	0.2	9	s
–	Block Erase Time (Program/Erase Endurance > 1,000 Times)	V <sub>CC</sub> = 5.0 V at T <sub>opr</sub> = 25 °C	–	0.3	–	s
t <sub>d</sub> (SR-ES)	Time Delay from Suspend Request until Erase Suspend		–	–	8	ms
–	Erase Suspend Request Interval		10	–	–	ms
–	Program, Erase Voltage		2.7	–	5.5	V
–	Read Voltage		2.7	–	5.5	V
–	Program, Erase Temperature		-20 <sup>(8)</sup>	–	85	°C
–	Data Hold Time <sup>(9)</sup>	Ambient temperature = 55 °C	20	–	–	year

## NOTES:

- V<sub>CC</sub> = AV<sub>CC</sub> = 2.7 to 5.5V at T<sub>opr</sub> = –20 to 85 °C / –40 to 85 °C, unless otherwise specified.
- Definition of program and erase  
The program and erase endurance shows an erase endurance for every block.  
If the program and erase endurance is “n” times (n = 100, 10000), “n” times erase can be performed for every block.  
For example, if performing 1-byte write to the distinct addresses on Block A of 1Kbyte block 1,024 times and then erasing that block, program and erase endurance is counted as one time.  
However, do not perform multiple programs to the same address for one time ease.(disable overwriting).
- Endurance to guarantee all electrical characteristics after program and erase.(1 to “Min.” value can be guaranteed).
- Standard of Block A and Block B when program and erase endurance exceeds 1,000 times. Byte program time to 1,000 times are the same as that in program area.
- In the case of a system to execute multiple programs, perform one erase after programming as reducing effective reprogram endurance not to leave blank area as possible such as programming write addresses in turn. If programming a set of 16 bytes, programming up to 128 sets and then erasing them one time can reduce effective reprogram endurance. Additionally, averaging erase endurance for Block A and B can reduce effective reprogram endurance more. To leave erase endurance for every block as information and determine the restricted endurance are recommended.
- If error occurs during block erase, attempt to execute the clear status register command, then the block erase command at least three times until the erase error does not occur.
- Customers desiring Program/Erase failure rate information should contact their Renesas technical support representative.
- 40 °C for D version.
- The data hold time includes time that the power supply is off or the clock is not supplied.



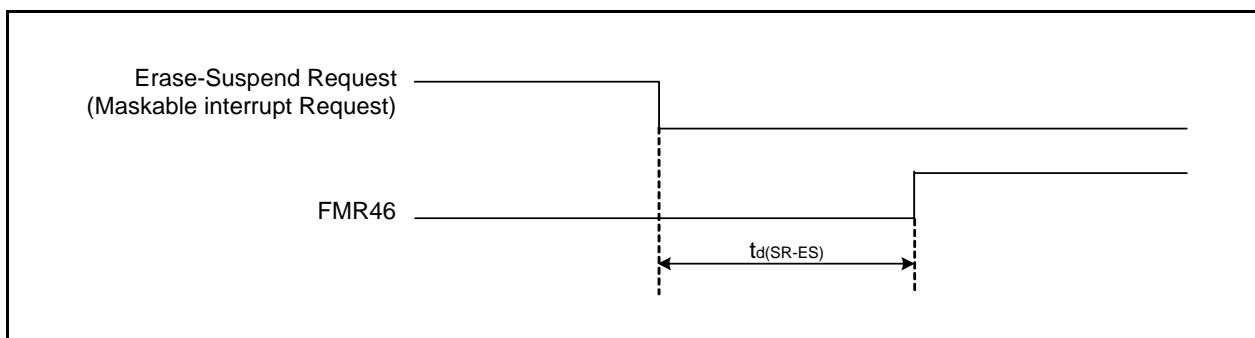

**Figure 5.2** Time delay from Suspend Request until Erase Suspend

**Table 5.6** Voltage Detection 1 Circuit Electrical Characteristics

Symbol	Parameter	Condition	Standard			Unit
			Min.	Typ.	Max.	
$V_{det1}$	Voltage Detection Level <sup>(3)</sup>		2.70	2.85	3.00	V
–	Voltage Detection Circuit Self Power Consumption	VCA26 = 1, $V_{CC} = 5.0V$	–	600	–	nA
$t_{d(E-A)}$	Waiting Time until Voltage Detection Circuit Operation Starts <sup>(2)</sup>		–	–	100	$\mu s$
$V_{CCmin}$	Microcomputer Operating Voltage Minimum Value		2.7	–	–	V

NOTES:

1. The measurement condition is  $V_{CC} = AV_{CC} = 2.7V$  to  $5.5V$  and  $T_{opr} = -40^{\circ}C$  to  $85^{\circ}C$ .
2. Necessary time until the voltage detection circuit operates when setting to "1" again after setting the VCA26 bit in the VCA2 register to "0".
3. Hold  $V_{det2} > V_{det1}$ .

**Table 5.7** Voltage Detection 2 Circuit Electrical Characteristics

Symbol	Parameter	Condition	Standard			Unit
			Min.	Typ.	Max.	
$V_{det2}$	Voltage Detection Level <sup>(4)</sup>		3.00	3.30	3.60	V
–	Voltage Monitor 2 Interrupt Request Generation Time <sup>(2)</sup>		–	40	–	$\mu s$
–	Voltage Detection Circuit Self Power Consumption	VCA27 = 1, $V_{CC} = 5.0V$	–	600	–	nA
$t_{d(E-A)}$	Waiting Time until Voltage Detection Circuit Operation Starts <sup>(3)</sup>		–	–	100	$\mu s$

NOTES:

1. The measurement condition is  $V_{CC} = AV_{CC} = 2.7V$  to  $5.5V$  and  $T_{opr} = -40^{\circ}C$  to  $85^{\circ}C$ .
2. Time until the voltage monitor 2 interrupt request is generated since the voltage passes  $V_{det1}$ .
3. Necessary time until the voltage detection circuit operates when setting to "1" again after setting the VCA27 bit in the VCA2 register to "0".
4. Hold  $V_{det2} > V_{det1}$ .

**Table 5.8 Reset Circuit Electrical Characteristics (When Using Voltage Monitor 1 Reset)**

Symbol	Parameter	Condition	Standard			Unit
			Min.	Typ.	Max.	
$V_{por2}$	Power-On Reset Valid Voltage	$-20^{\circ}\text{C} \leq T_{opr} < 85^{\circ}\text{C}$	–	–	$V_{det1}$	V
$t_w(V_{por2}-V_{det1})$	Supply Voltage Rising Time When Power-On Reset is Deasserted <sup>(1)</sup>	$-20^{\circ}\text{C} \leq T_{opr} < 85^{\circ}\text{C}$ , $t_w(por2) \geq 0\text{s}^{(3)}$	–	–	100	ms

## NOTES:

1. This condition is not applicable when using with  $V_{cc} \geq 1.0\text{V}$ .
2. When turning power on after the time to hold the external power below effective voltage ( $V_{por1}$ ) exceeds 10s, refer to **Table 5.9 Reset Circuit Electrical Characteristics (When Not Using Voltage Monitor 1 Reset)**.
3.  $t_w(por2)$  is time to hold the external power below effective voltage ( $V_{por2}$ ).

**Table 5.9 Reset Circuit Electrical Characteristics (When Not Using Voltage Monitor 1 Reset)**

Symbol	Parameter	Condition	Standard			Unit
			Min.	Typ.	Max.	
$V_{por1}$	Power-On Reset Valid Voltage	$-20^{\circ}\text{C} \leq T_{opr} < 85^{\circ}\text{C}$	–	–	0.1	V
$t_w(V_{por1}-V_{det1})$	Supply Voltage Rising Time When Power-On Reset is Deasserted	$0^{\circ}\text{C} \leq T_{opr} \leq 85^{\circ}\text{C}$ , $t_w(por1) \geq 10\text{s}^{(2)}$	–	–	100	ms
$t_w(V_{por1}-V_{det1})$	Supply Voltage Rising Time When Power-On Reset is Deasserted	$-20^{\circ}\text{C} \leq T_{opr} < 0^{\circ}\text{C}$ , $t_w(por1) \geq 30\text{s}^{(2)}$	–	–	100	ms
$t_w(V_{por1}-V_{det1})$	Supply Voltage Rising Time When Power-On Reset is Deasserted	$-20^{\circ}\text{C} \leq T_{opr} < 0^{\circ}\text{C}$ , $t_w(por1) \geq 10\text{s}^{(2)}$	–	–	1	ms
$t_w(V_{por1}-V_{det1})$	Supply Voltage Rising Time When Power-On Reset is Deasserted	$0^{\circ}\text{C} \leq T_{opr} \leq 85^{\circ}\text{C}$ , $t_w(por1) \geq 1\text{s}^{(2)}$	–	–	0.5	ms

## NOTES:

1. When not using the voltage monitor 1 reset, use with  $V_{cc} \geq 2.7\text{V}$ .
2.  $t_w(por1)$  is time to hold the external power below effective voltage ( $V_{por1}$ ).

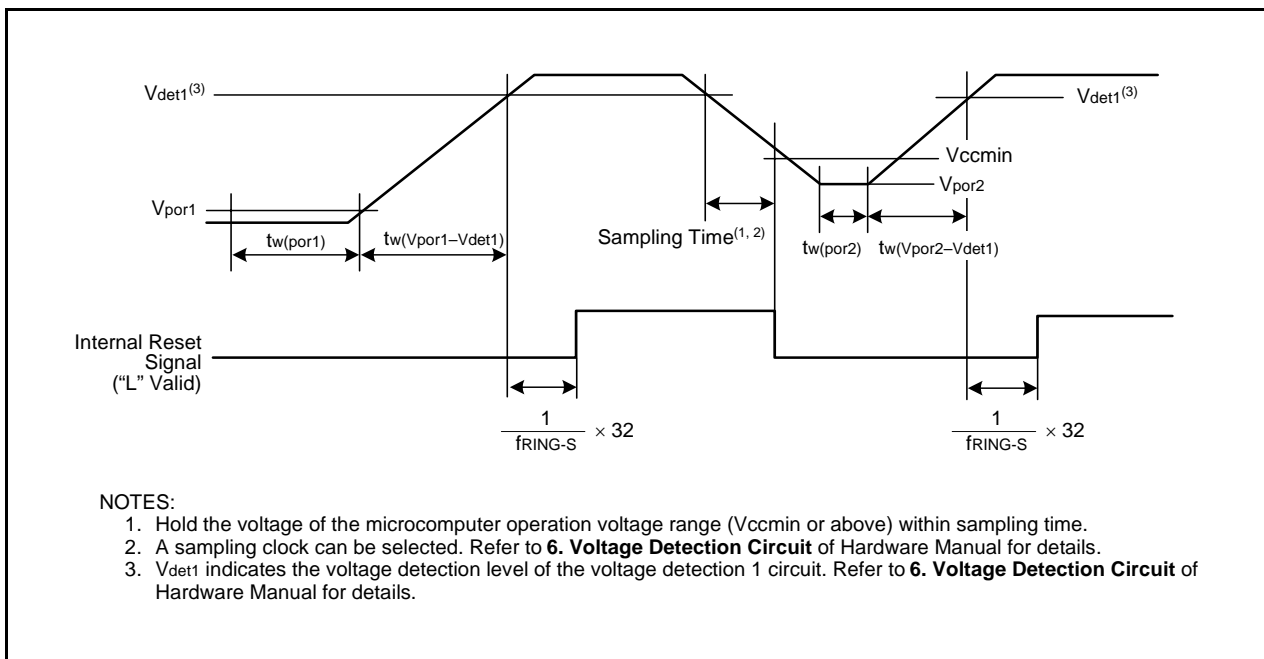

## NOTES:

1. Hold the voltage of the microcomputer operation voltage range ( $V_{ccmin}$  or above) within sampling time.
2. A sampling clock can be selected. Refer to **6. Voltage Detection Circuit** of Hardware Manual for details.
3.  $V_{det1}$  indicates the voltage detection level of the voltage detection 1 circuit. Refer to **6. Voltage Detection Circuit** of Hardware Manual for details.

**Figure 5.3 Reset Circuit Electrical Characteristics**

**Table 5.10 High-speed On-Chip Oscillator Circuit Electrical Characteristics**

Symbol	Parameter	Condition	Standard			Unit
			Min.	Typ.	Max.	
–	High-Speed On-Chip Oscillator Frequency When the Reset is Deasserted	$V_{CC} = 5.0V$ , $T_{opr} = 25\text{ }^{\circ}C$	–	8	–	MHz
–	High-Speed On-Chip Oscillator Frequency Temperature • Supplay Voltage Dependence	0 to +60 $^{\circ}C$ / 5 V $\pm$ 5 % <sup>(2)</sup>	7.44	–	8.56	MHz
		–20 to +85 $^{\circ}C$ / 2.7 to 5.5 V <sup>(2)</sup>	7.04	–	8.96	MHz
		–40 to +85 $^{\circ}C$ / 2.7 to 5.5 V <sup>(2)</sup>	6.80	–	9.20	MHz

## NOTES:

1. The measurement condition is  $V_{CC} = AV_{CC} = 5.0V$  and  $T_{opr} = 25\text{ }^{\circ}C$ .
2. The standard value shows when the HRA1 register is assumed as the value in shipping and the HRA2 register value is set to 00h.

**Table 5.11 Power Supply Circuit Timing Characteristics**

Symbol	Parameter	Condition	Standard			Unit
			Min.	Typ.	Max.	
$t_{d(P-R)}$	Time for Internal Power Supply Stabilization during Power-On <sup>(2)</sup>		1	–	2000	$\mu s$
$t_{d(R-S)}$	STOP Exit Time <sup>(3)</sup>		–	–	150	$\mu s$

## NOTES:

1. The measurement condition is  $V_{CC} = AV_{CC} = 2.7$  to  $5.5V$  and  $T_{opr} = 25\text{ }^{\circ}C$ .
2. Waiting time until the internal power supply generation circuit stabilizes during power-on.
3. Time until CPU clock supply starts since the interrupt is acknowledged to exit stop mode.

**Table 5.12 Timing Requirements of I<sup>2</sup>C bus Interface (IIC) (1)**

Symbol	Parameter	Condition	Standard			Unit
			Min.	Typ.	Max.	
tSCL	SCL Input Cycle Time		12tCYC+600 <sup>(2)</sup>	–	–	ns
tSCLH	SCL Input “H” Width		3tCYC+300 <sup>(2)</sup>	–	–	ns
tSCLL	SCL Input “L” Width		5tCYC+300 <sup>(2)</sup>	–	–	ns
tsf	SCL, SDA Input Fall Time		–	–	300	ns
tSP	SCL, SDA Input Spike Pulse Rejection Time		–	–	1tCYC <sup>(2)</sup>	ns
tBUF	SDA Input Bus-Free Time		5tCYC <sup>(2)</sup>	–	–	ns
tSTAH	Start Condition Input Hold Time		3tCYC <sup>(2)</sup>	–	–	ns
tSTAS	Retransmit Start Condition Input SetUp Time		3tCYC <sup>(2)</sup>	–	–	ns
tSTOS	Stop Condition Input SetUp Time		3tCYC <sup>(2)</sup>	– <td –	ns	
tSDAS	Data Input SetUp Time		1tCYC+20 <sup>(2)</sup>	–	–	ns
tSDAH	Data Input Hold Time		0	–	–	ns

## NOTES:

1. V<sub>CC</sub> = AV<sub>CC</sub> = 2.7 to 5.5V, V<sub>SS</sub> = 0V and Topr = -20 to 85 °C / -40 to 85 °C, unless otherwise specified.
2. 1tCYC=1/f1(s)

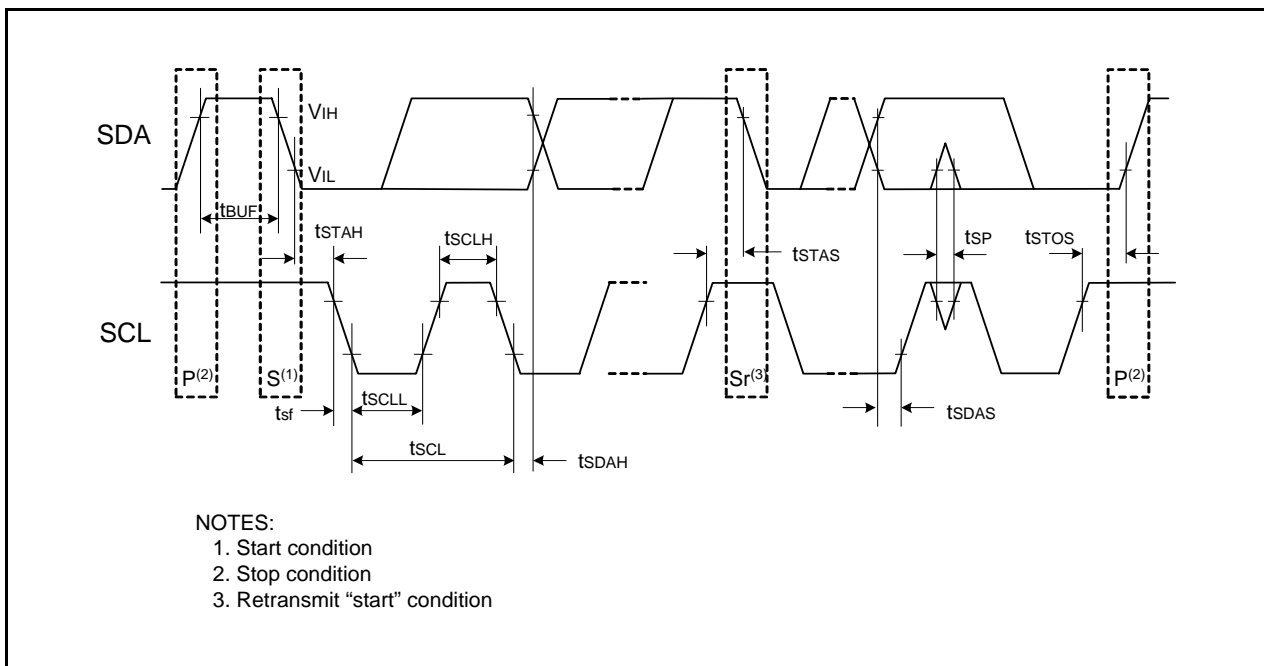
**Figure 5.4 I/O Timing of I<sup>2</sup>C bus Interface (IIC)**

**Table 5.13 Electrical Characteristics (1) [Vcc = 5V]**

Symbol	Parameter		Condition	Standard			Unit	
				Min.	Typ.	Max.		
VOH	Output "H" Voltage	Except XOUT	IOH = -5mA		Vcc - 2.0	-	Vcc	V
			IOH = -200μA		Vcc - 0.3	-	Vcc	V
		XOUT	Drive capacity HIGH	IOH = -1mA	Vcc - 2.0	-	Vcc	V
			Drive capacity LOW	IOH = -500μA	Vcc - 2.0	-	Vcc	V
VOL	Output "L" Voltage	Except P1_0 to P1_3, XOUT	IOL = 5mA		-	-	2.0	V
			IOL = 200μA		-	-	0.45	V
		P1_0 to P1_3	Drive capacity HIGH	IOL = 15mA	-	-	2.0	V
			Drive capacity LOW	IOL = 5mA	-	-	2.0	V
			Drive capacity LOW	IOL = 200μA	-	-	0.45	V
		XOUT	Drive capacity HIGH	IOL = 1mA	-	-	2.0	V
			Drive capacity LOW	IOL = 500μA	-	-	2.0	V
		VT+-VT-	Hysteresis	INT0, INT1, INT3, KI0, KI1, KI2, KI3, CNTR0, CNTR1, TCIN, RXD0			0.2	-
RESET				0.2	-	2.2	V	
IiH	Input "H" current			VI = 5V	-	-	5.0	μA
IiL	Input "L" current			VI = 0V	-	-	-5.0	μA
RPULLUP	Pull-Up Resistance			VI = 0V	30	50	167	kΩ
RfXIN	Feedback Resistance	XIN			-	1.0	-	MΩ
fRING-S	Low-Speed On-Chip Oscillator Frequency				40	125	250	kHz
V <sub>RAM</sub>	RAM Hold Voltage			During stop mode	2.0	-	-	V

## NOTES:

1. Vcc = AVcc = 4.2 to 5.5V at Topr = -20 to 85 °C / -40 to 85 °C, f(XIN)=20MHz, unless otherwise specified.

**Table 5.14 Electrical Characteristics (2) [Vcc = 5V] (Topr = -40 to 85 °C, unless otherwise specified.)**

Symbol	Parameter	Condition	Standard			Unit	
			Min.	Typ.	Max.		
Icc	Power Supply Current (Vcc=3.3 to 5.5V) In single-chip mode, the output pins are open and other pins are Vss	High-Speed Mode	XIN = 20MHz (square wave) High-speed on-chip oscillator off Low-speed on-chip oscillator on=125kHz No division	–	9	15	mA
			XIN = 16MHz (square wave) High-speed on-chip oscillator off Low-speed on-chip oscillator on=125kHz No division	–	8	14	mA
			XIN = 10MHz (square wave) High-speed on-chip oscillator off Low-speed on-chip oscillator on=125kHz No division	–	5	–	mA
		Medium-Speed Mode	XIN = 20MHz (square wave) High-speed on-chip oscillator off Low-speed on-chip oscillator on=125kHz Divide-by-8	–	4	–	mA
			XIN = 16MHz (square wave) High-speed on-chip oscillator off Low-speed on-chip oscillator on=125kHz Divide-by-8	–	3	–	mA
			XIN = 10MHz (square wave) High-speed on-chip oscillator off Low-speed on-chip oscillator on=125kHz Divide-by-8	–	2	–	mA
		High-Speed On-Chip Oscillator Mode	Main clock off High-speed on-chip oscillator on=8MHz Low-speed on-chip oscillator on=125kHz No division	–	4	8	mA
			Main clock off High-speed on-chip oscillator on=8MHz Low-speed on-chip oscillator on=125kHz Divide-by-8	–	1.5	–	mA
		Low-Speed On-Chip Oscillator Mode	Main clock off High-speed on-chip oscillator off Low-speed on-chip oscillator on=125kHz Divide-by-8	–	470	900	μA
		Wait Mode	Main clock off High-speed on-chip oscillator off Low-speed on-chip oscillator on=125kHz While a WAIT instruction is executed Peripheral clock operation VCA26 = VCA27 = 0	–	40	80	μA
		Wait Mode	Main clock off High-speed on-chip oscillator off Low-speed on-chip oscillator on=125kHz While a WAIT instruction is executed Peripheral clock off VCA26 = VCA27 = 0	–	38	76	μA
		Stop Mode	Main clock off, Topr = 25 °C High-speed on-chip oscillator off Low-speed on-chip oscillator off CM10 = 1 Peripheral clock off VCA26 = VCA27 = 0	–	0.8	3.0	μA

**Timing Requirements (Unless otherwise specified: V<sub>CC</sub> = 5V, V<sub>SS</sub> = 0V at Topr = 25 °C) [ V<sub>CC</sub> = 5V ]****Table 5.15 XIN Input**

Symbol	Parameter	Standard		Unit
		Min.	Max.	
t <sub>c</sub> (XIN)	XIN Input Cycle Time	50	–	ns
t <sub>WH</sub> (XIN)	XIN Input “H” Width	25	–	ns
t <sub>WL</sub> (XIN)	XIN Input “L” Width	25	–	ns

**Table 5.16 CNTR0 Input, CNTR1 Input,  $\overline{\text{INT1}}$  Input**

Symbol	Parameter	Standard		Unit
		Min.	Max.	
t <sub>c</sub> (CNTR0)	CNTR0 Input Cycle Time	100	–	ns
t <sub>WH</sub> (CNTR0)	CNTR0 Input “H” Width	40	–	ns
t <sub>WL</sub> (CNTR0)	CNTR0 input “L” Width	40	–	ns

**Table 5.17 TCIN Input,  $\overline{\text{INT3}}$  Input**

Symbol	Parameter	Standard		Unit
		Min.	Max.	
t <sub>c</sub> (TCIN)	TCIN Input Cycle Time	400 <sup>(1)</sup>	–	ns
t <sub>WH</sub> (TCIN)	TCIN Input “H” Width	200 <sup>(2)</sup>	–	ns
t <sub>WL</sub> (TCIN)	TCIN input “L” Width	200 <sup>(2)</sup>	–	ns

## NOTES:

1. When using Timer C input capture mode, adjust the cycle time ( 1/ Timer C count source frequency x 3) or above.
2. When using Timer C input capture mode, adjust the width ( 1/ Timer C count source frequency x 1.5) or above.

**Table 5.18 Serial Interface**

Symbol	Parameter	Standard		Unit
		Min.	Max.	
t <sub>c</sub> (CK)	CLKi Input Cycle Time	200	–	ns
t <sub>W</sub> (CKH)	CLKi Input “H” Width	100	–	ns
t <sub>W</sub> (CKL)	CLKi Input “L” Width	100	–	ns
t <sub>d</sub> (C-Q)	TXDi Output Delay Time	–	50	ns
t <sub>h</sub> (C-Q)	TXDi Hold Time	0	–	ns
t <sub>su</sub> (D-C)	RXD <sub>i</sub> Input Setup Time	50	–	ns
t <sub>h</sub> (C-D)	RCD <sub>i</sub> Input Hold Time	90	–	ns

**Table 5.19 External Interrupt  $\overline{\text{INT0}}$  Input**

Symbol	Parameter	Standard		Unit
		Min.	Max.	
t <sub>W</sub> (INH)	$\overline{\text{INT0}}$ Input “H” Width	250 <sup>(1)</sup>	–	ns
t <sub>W</sub> (INL)	$\overline{\text{INT0}}$ Input “L” Width	250 <sup>(2)</sup>	–	ns

## NOTES:

1. When selecting the digital filter by the  $\overline{\text{INT0}}$  input filter select bit, use the  $\overline{\text{INT0}}$  input HIGH width to the greater value, either (1/ digital filter clock frequency x 3) or the minimum value of standard.
2. When selecting the digital filter by the  $\overline{\text{INT0}}$  input filter select bit, use the  $\overline{\text{INT0}}$  input LOW width to the greater value, either (1/ digital filter clock frequency x 3) or the minimum value of standard.

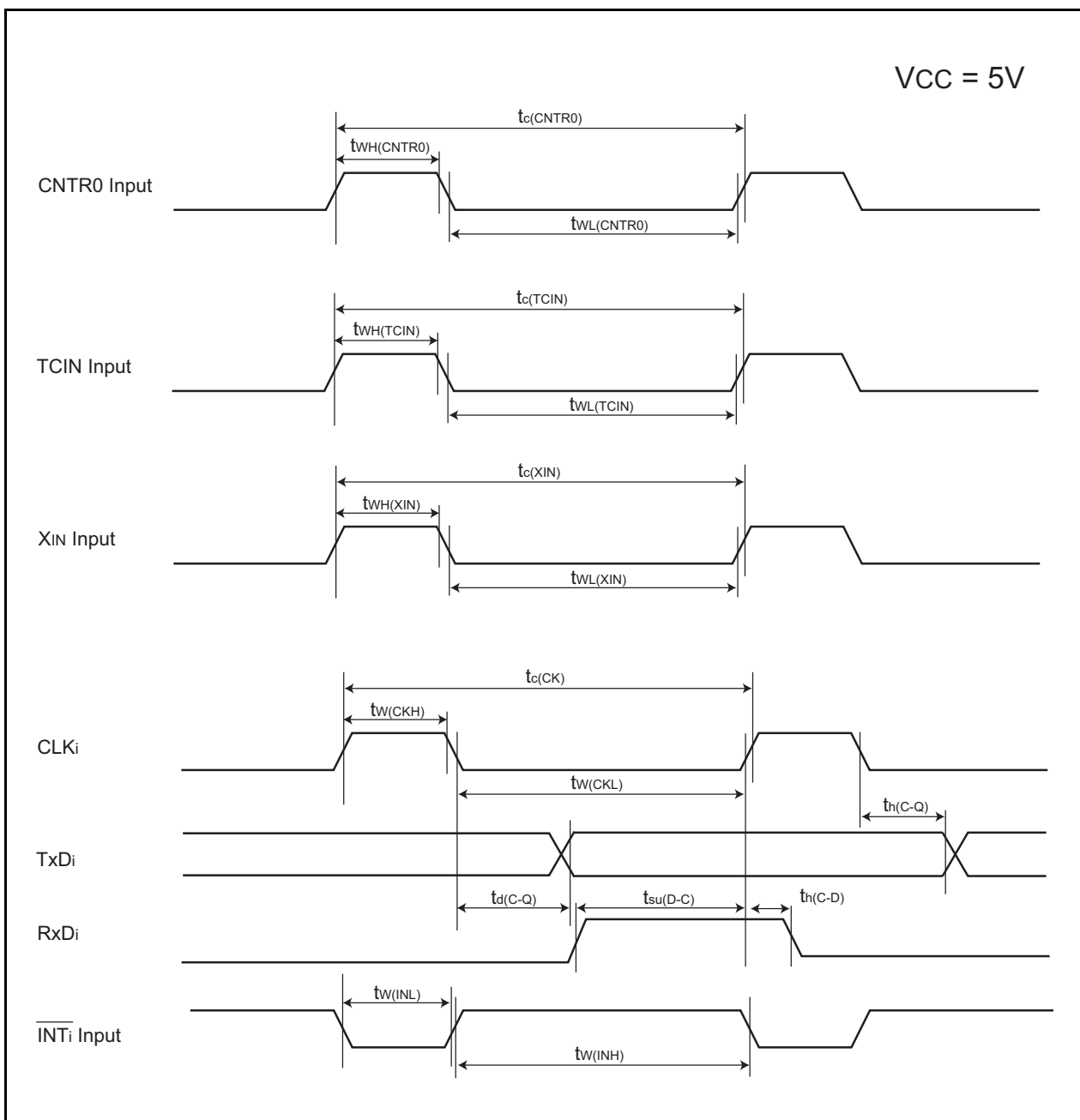

Figure 5.5 Timing Diagram When  $V_{CC} = 5V$



**Table 5.20 Electrical Characteristics (3) [Vcc = 3V]**

Symbol	Parameter		Condition		Standard			Unit
					Min.	Typ.	Max.	
VOH	Output "H" Voltage	Except XOUT	IOH = -1mA		Vcc - 0.5	-	Vcc	V
		XOUT	Drive capacity HIGH	IOH = -0.1mA	Vcc - 0.5	-	Vcc	V
			Drive capacity LOW	IOH = -50μA	Vcc - 0.5	-	Vcc	V
VOL	Output "L" Voltage	Except P1_0 to P1_3, XOUT	IOL = 1mA		-	-	0.5	V
		P1_0 to P1_3	Drive capacity HIGH	IOL = 2mA	-	-	0.5	V
			Drive capacity LOW	IOL = 1mA	-	-	0.5	V
		XOUT	Drive capacity HIGH	IOL = 0.1mA	-	-	0.5	V
			Drive capacity LOW	IOL = 50μA	-	-	0.5	V
VT+-VT-	Hysteresis	$\overline{\text{INT0}}, \overline{\text{INT1}}, \overline{\text{INT3}},$ K10, K11, K12, K13, CNTR0, CNTR1, TCIN, RXD0			0.2	-	0.8	V
		$\overline{\text{RESET}}$			0.2	-	1.8	V
I <sub>IH</sub>	Input "H" Current		VI = 3V		-	-	4.0	μA
I <sub>IL</sub>	Input "L" Current		VI = 0V		-	-	-4.0	μA
RPULLUP	Pull-Up Resistance		VI = 0V		66	160	500	kΩ
R <sub>iXIN</sub>	Feedback Resistance	XIN			-	3.0	-	MΩ
f <sub>FRING-S</sub>	Low-Speed On-Chip Oscillator Frequency				40	125	250	kHz
V <sub>RAM</sub>	RAM Hold Voltage		During stop mode		2.0	-	-	V

## NOTES:

- Vcc = AVcc = 2.7 to 3.3V at Topr = -20 to 85 °C / -40 to 85 °C, f(XIN)=10MHz, unless otherwise specified.

**Table 5.21 Electrical Characteristics (4) [Vcc = 3V] (Topr = -40 to 85 °C, unless otherwise specified.)**

Symbol	Parameter	Condition	Standard			Unit	
			Min.	Typ.	Max.		
Icc	Power Supply Current (Vcc=2.7 to 3.3V) In single-chip mode, the output pins are open and other pins are Vss	High-Speed Mode	XIN = 20MHz (square wave) High-speed on-chip oscillator off Low-speed on-chip oscillator on=125kHz No division	–	8	13	mA
			XIN = 16MHz (square wave) High-speed on-chip oscillator off Low-speed on-chip oscillator on=125kHz No division	–	7	12	mA
			XIN = 10MHz (square wave) High-speed on-chip oscillator off Low-speed on-chip oscillator on=125kHz No division	–	5	–	mA
		Medium-Speed Mode	XIN = 20MHz (square wave) High-speed on-chip oscillator off Low-speed on-chip oscillator on=125kHz Divide-by-8	–	3	–	mA
			XIN = 16MHz (square wave) High-speed on-chip oscillator off Low-speed on-chip oscillator on=125kHz Divide-by-8	–	2.5	–	mA
			XIN = 10MHz (square wave) High-speed on-chip oscillator off Low-speed on-chip oscillator on=125kHz Divide-by-8	–	1.6	–	mA
		High-Speed On-Chip Oscillator Mode	Main clock off High-speed on-chip oscillator on=8MHz Low-speed on-chip oscillator on=125kHz No division	–	3.5	7.5	mA
			Main clock off High-speed on-chip oscillator on=8MHz Low-speed on-chip oscillator on=125kHz Divide-by-8	–	1.5	–	mA
		Low-Speed On-Chip Oscillator Mode	Main clock off High-speed on-chip oscillator off Low-speed on-chip oscillator on=125kHz Divide-by-8	–	420	800	μA
		Wait Mode	Main clock off High-speed on-chip oscillator off Low-speed on-chip oscillator on=125kHz While a WAIT instruction is executed Peripheral clock operation VCA26 = VCA27 = 0	–	37	74	μA
		Wait Mode	Main clock off High-speed on-chip oscillator off Low-speed on-chip oscillator on=125kHz While a WAIT instruction is executed Peripheral clock off VCA26 = VCA27 = 0	–	35	70	μA
		Stop Mode	Main clock off, Topr = 25 °C High-speed on-chip oscillator off Low-speed on-chip oscillator off CM10 = 1 Peripheral clock off VCA26 = VCA27 = 0	–	0.7	3.0	μA

**Timing requirements (Unless otherwise specified: Vcc = 3V, Vss = 0V at Topr = 25 °C) [Vcc = 3V]****Table 5.22 XIN Input**

Symbol	Parameter	Standard		Unit
		Min.	Max.	
t <sub>c</sub> (XIN)	XIN Input Cycle Time	100	–	ns
t <sub>WH</sub> (XIN)	XIN Input “H” Width	40	–	ns
t <sub>WL</sub> (XIN)	XIN Input “L” Width	40	–	ns

**Table 5.23 CNTR0 Input, CNTR1 Input,  $\overline{\text{INT1}}$  Input**

Symbol	Parameter	Standard		Unit
		Min.	Max.	
t <sub>c</sub> (CNTR0)	CNTR0 Input Cycle Time	300	–	ns
t <sub>WH</sub> (CNTR0)	CNTR0 Input “H” Width	120	–	ns
t <sub>WL</sub> (CNTR0)	CNTR0 Input “L” Width	120	–	ns

**Table 5.24 TCIN Input,  $\overline{\text{INT3}}$  Input**

Symbol	Parameter	Standard		Unit
		Min.	Max.	
t <sub>c</sub> (TCIN)	TCIN Input Cycle Time	1,200 <sup>(1)</sup>	–	ns
t <sub>WH</sub> (TCIN)	TCIN Input “H” Width	600 <sup>(2)</sup>	–	ns
t <sub>WL</sub> (TCIN)	TCIN Input “L” Width	600 <sup>(2)</sup>	–	ns

## NOTES:

1. When using the Timer C input capture mode, adjust the cycle time (1/ Timer C count source frequency x 3) or above.
2. When using the Timer C input capture mode, adjust the width (1/ Timer C count source frequency x 1.5) or above.

**Table 5.25 Serial Interface**

Symbol	Parameter	Standard		Unit
		Min.	Max.	
t <sub>c</sub> (CK)	CLKi Input Cycle Time	300	–	ns
t <sub>W</sub> (CKH)	CLKi Input “H” Width	150	–	ns
t <sub>W</sub> (CKL)	CLKi Input “L” Width	150	–	ns
t <sub>d</sub> (C-Q)	TXDi Output Delay Time	–	80	ns
t <sub>h</sub> (C-Q)	TXDi Hold Time	0	–	ns
t <sub>su</sub> (D-C)	RXDi Input Setup Time	70	–	ns
t <sub>h</sub> (C-D)	RCDi Input Hold Time	90	–	ns

**Table 5.26 External Interrupt  $\overline{\text{INT0}}$  Input**

Symbol	Parameter	Standard		Unit
		Min.	Max.	
t <sub>W</sub> (INH)	$\overline{\text{INT0}}$ Input “H” Width	380 <sup>(1)</sup>	–	ns
t <sub>W</sub> (INL)	$\overline{\text{INT0}}$ Input “L” Width	380 <sup>(2)</sup>	–	ns

## NOTES:

1. When selecting the digital filter by the  $\overline{\text{INT0}}$  input filter select bit, use the  $\overline{\text{INT0}}$  input HIGH width to the greater value, either (1/ digital filter clock frequency x 3) or the minimum value of standard.
2. When selecting the digital filter by the  $\overline{\text{INT0}}$  input filter select bit, use the  $\overline{\text{INT0}}$  input LOW width to the greater value, either (1/ digital filter clock frequency x 3) or the minimum value of standard.

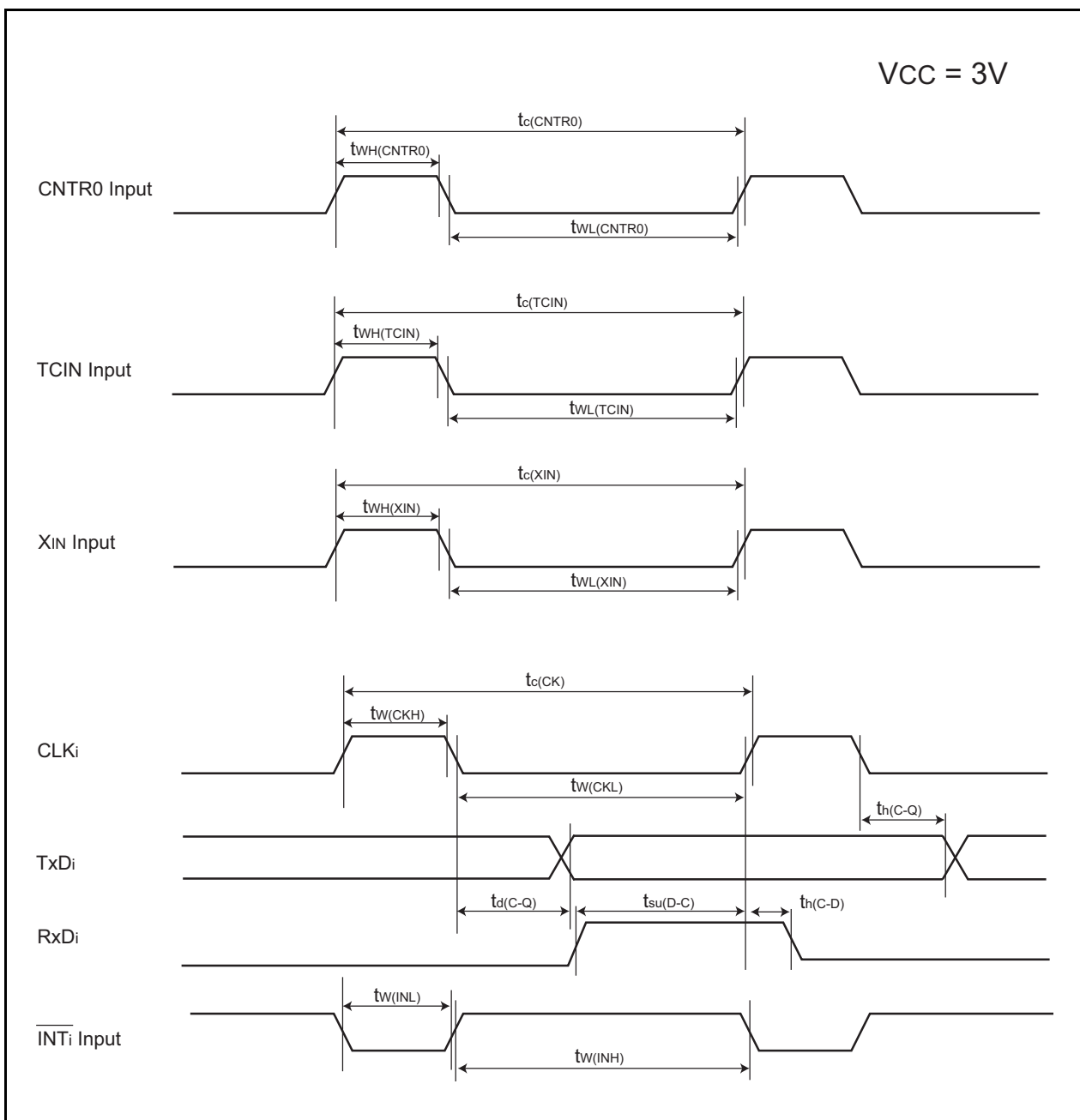
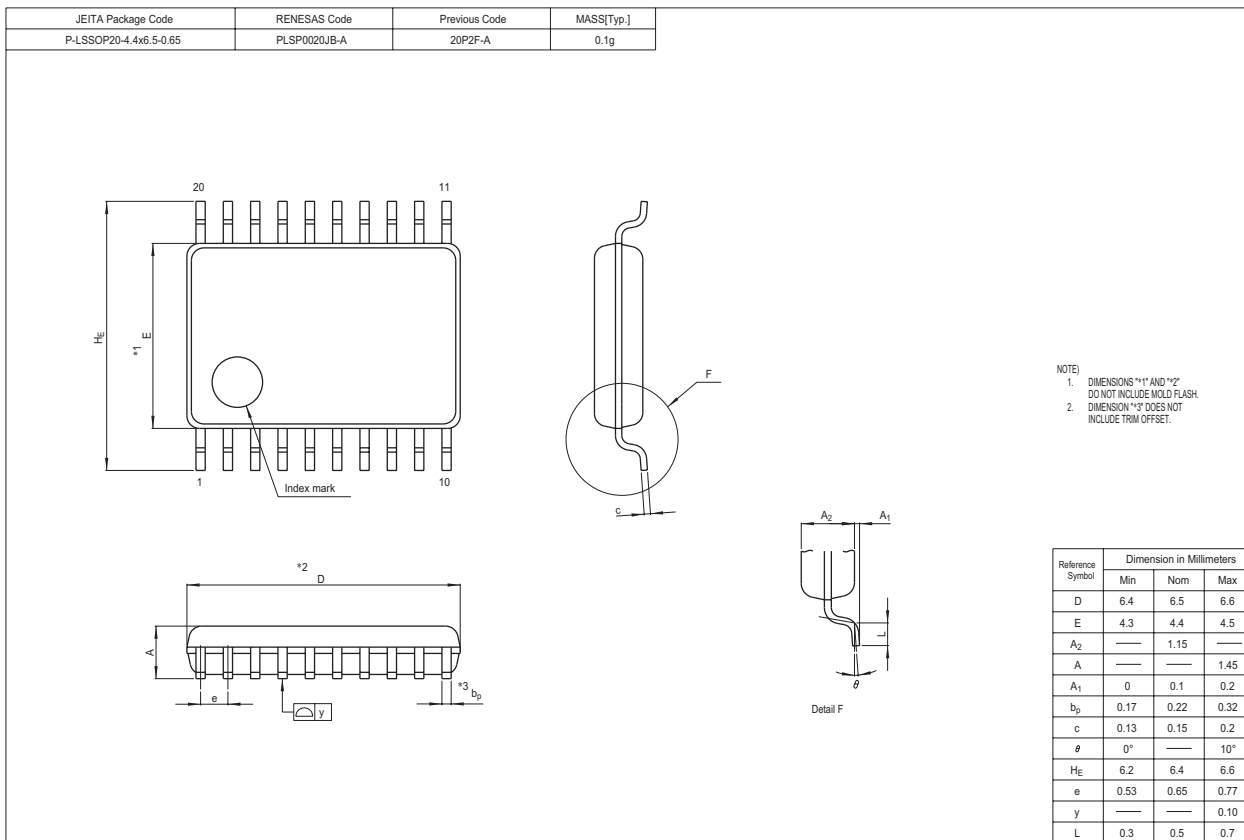

Figure 5.6 Timing Diagram When  $V_{CC} = 3V$

# Package Dimensions



REVISION HISTORY

R8C/16 Group, R8C/17 Group Datasheet

Rev.	Date	Description	
		Page	Summary
0.10	Sep 06, 2004	–	First Edition issued
1.00	Feb 25, 2005	2-3 5 6 7-8 16 18 21 22 24 25 26 27 28 29, 33 31 32 35	Tables 1.1 and 1.2 revised Table 1.3 and figure 1.2 revised Table 1.4 and figure 1.3 revised Figures 1.4 and 1.5 revised Table 4.1 revised: - 000Fh: 000XXXXXb → 00011111b - 0036h: 00001000b → 0000X000b and 01001001b → 0100X001b Table 4.3 revised: - 009Ch: FFh → 00h; NOTES2 added - 009Dh: FFh → 00h Table 5.3 revised Tables 5.4 and 5.5 revised Tables 5.8 and 5.9 revised Table 5.11 revised Table 5.12 and figure 5.4 added Table 5.13 revised Table 5.14 revised Table 5.16 and 5.23 revised: Table title “INT2” → “INT1” Table 5.20 revised; NOTE revised Table 5.21 revised Package Dimensions revised
1.10	May 26, 2005	5, 6 16 22 26 27 31	Tables 1.3 and 1.4 revised Table 4.1 revised: - 0009h: XXXXXX00b → 00h - 000Ah: 00XXX000b → 00h - 001Eh: XXXXX000b → 00h Table 5.5 revised; NOTE revised Fig 5.4 revised Table 5.13 revised Table 5.20 revised
2.00	Jan 30, 2006	1 2 3 4 5, 6	1. Overview; “20-pin plastic molded LSSOP or SDIP” → “20-pin plastic molded LSSOP” revised Table 1.1 Performance Outline of the R8C/16 Group; Package: “20-pin plastic molded SDIP” deleted Table 1.2 Performance Outline of the R8C/17 Group; Package: “20-pin plastic molded SDIP” deleted, Flash Memory: (Data area) → (Data flash) (Program area) → (Program ROM) revised Figure 1.1 Block Diagram; “Peripheral Function” added, “System Clock Generation” → “System Clock Generator” revised Table 1.3 Product Information of R8C/16 Group, Table 1.4 Product Information of R8C/17 Group; revised. Figure 1.2 Part Number, Memory Size and Package of R8C/16 Group, Figure 1.3 Part Number, Memory Size and Package of R8C/17 Group; Package type: “DD : PRDP0020BA-A” deleted

REVISION HISTORY

R8C/16 Group, R8C/17 Group Datasheet

Rev.	Date	Description	
		Page	Summary
2.00	Jan 30, 2006	8	Figure 1.5 PRDP0020BA-A Package Pin Assignment (top view) deleted Table 1.5 Pin Description; Timer C: "CMP0_0 to CMP0_3, CMP1_0 to CMP1_3" → "CMP0_0 to CMP0_2, CMP1_0 to CMP1_2" revised
		10	Figure 2.1 CPU Register; "Reserved Area" → "Reserved Bit" revised
		12	2.8.10 Reserved Area; "Reserved Area" → "Reserved Bit" revised
		13	Figure 3.1 Memory Map of R8C/16 Group revised
		14	3.2 R8C/17 Group; (program area) → (program ROM), (data area) → (data flash) revised
		17	Figure 3.2 Memory Map of R8C/17 Group revised Table 4.3 SFR Information(3); 0085h: "Prescaler Z" → "Prescaler Z Register" 0086h: "Timer Z Secondary" → "Timer Z Secondary Register" 0087h: "Timer Z Primary" → "Timer Z Primary Register" 008Ch: "Prescaler X" → "Prescaler X Register" 008Dh: "Timer X" → "Timer X Register" 0090h, 0091h: "Timer C" → "Timer C Register" revised
		21	Table 5.4 Flash Memory (Program ROM) Electrical Characteristics; •NOTES 1 to 7 added •"Topr" → "Ambient temperature", "(Program area)" → "(Program ROM)" revised
		22	Table 5.5 Flash Memory (Data flash Block A, Block B) Electrical Characteristics; •NOTE1 revised, NOTE9 added •"Topr" → "Ambient temperature", "(Program area)" → "(Program ROM)" revised
		23	Figure 5.2 Time delay from Suspend Request until Erase Suspend revised Table 5.7 Voltage Detection 2 Circuit Electrical Characteristics; NOTE1 revised
		24	Table 5.8 Reset Circuit Electrical Characteristics (When Using Voltage Monitor 1 Reset ); NOTE2 revised Table 5.9 Reset Circuit Electrical Characteristics (When Not Using Voltage Monitor 1 Reset); NOTE1 revised
		25	Table 5.10 High-speed On-Chip Oscillator Circuit Electrical Characteristics revised
		26	Table 5.12 Timing Requirements of I2C bus Interface (IIC); NOTE1 revised
		28	Table 5.14 Electrical Characteristics (2) [Vcc = 5V] revised
		29	"Timing Requirements (Unless ... at Ta = 25°C) [ VCC = 5V ]" → "Timing Requirements (Unless ... at Topr = 25°C) [ VCC = 5V ]" revised
		32	Table 5.18 Serial Interface; "35" → "50", "80" → "50"
		33	Table 5.21 Electrical Characteristics (4) [Vcc = 3V] revised "Timing requirements (Unless ... at Ta = 25°C) [VCC = 3V]" → "Timing requirements (Unless ... at Topr = 25°C) [VCC = 3V]" revised
		35	Table 5.25 Serial Interface; "55" → "70", "160" → "70" Package Dimensions; Package "PRDP0020BA-A" deleted

**Keep safety first in your circuit designs!**

1. Renesas Technology Corp. puts the maximum effort into making semiconductor products better and more reliable, but there is always the possibility that trouble may occur with them. Trouble with semiconductors may lead to personal injury, fire or property damage.  
Remember to give due consideration to safety when making your circuit designs, with appropriate measures such as (i) placement of substitutive, auxiliary circuits, (ii) use of nonflammable material or (iii) prevention against any malfunction or mishap.

**Notes regarding these materials**

1. These materials are intended as a reference to assist our customers in the selection of the Renesas Technology Corp. product best suited to the customer's application; they do not convey any license under any intellectual property rights, or any other rights, belonging to Renesas Technology Corp. or a third party.
  2. Renesas Technology Corp. assumes no responsibility for any damage, or infringement of any third-party's rights, originating in the use of any product data, diagrams, charts, programs, algorithms, or circuit application examples contained in these materials.
  3. All information contained in these materials, including product data, diagrams, charts, programs and algorithms represents information on products at the time of publication of these materials, and are subject to change by Renesas Technology Corp. without notice due to product improvements or other reasons. It is therefore recommended that customers contact Renesas Technology Corp. or an authorized Renesas Technology Corp. product distributor for the latest product information before purchasing a product listed herein.  
The information described here may contain technical inaccuracies or typographical errors.  
Renesas Technology Corp. assumes no responsibility for any damage, liability, or other loss rising from these inaccuracies or errors.  
Please also pay attention to information published by Renesas Technology Corp. by various means, including the Renesas Technology Corp. Semiconductor home page (<http://www.renesas.com>).
  4. When using any or all of the information contained in these materials, including product data, diagrams, charts, programs, and algorithms, please be sure to evaluate all information as a total system before making a final decision on the applicability of the information and products. Renesas Technology Corp. assumes no responsibility for any damage, liability or other loss resulting from the information contained herein.
  5. Renesas Technology Corp. semiconductors are not designed or manufactured for use in a device or system that is used under circumstances in which human life is potentially at stake. Please contact Renesas Technology Corp. or an authorized Renesas Technology Corp. product distributor when considering the use of a product contained herein for any specific purposes, such as apparatus or systems for transportation, vehicular, medical, aerospace, nuclear, or undersea repeater use.
  6. The prior written approval of Renesas Technology Corp. is necessary to reprint or reproduce in whole or in part these materials.
  7. If these products or technologies are subject to the Japanese export control restrictions, they must be exported under a license from the Japanese government and cannot be imported into a country other than the approved destination.  
Any diversion or reexport contrary to the export control laws and regulations of Japan and/or the country of destination is prohibited.
  8. Please contact Renesas Technology Corp. for further details on these materials or the products contained therein.
- 



**RENESAS SALES OFFICES**

<http://www.renesas.com>

Refer to "<http://www.renesas.com/en/network>" for the latest and detailed information.

**Renesas Technology America, Inc.**

450 Holger Way, San Jose, CA 95134-1368, U.S.A  
Tel: <1> (408) 382-7500, Fax: <1> (408) 382-7501

**Renesas Technology Europe Limited**

Dukes Meadow, Millboard Road, Bourne End, Buckinghamshire, SL8 5FH, U.K.  
Tel: <44> (1628) 585-100, Fax: <44> (1628) 585-900

**Renesas Technology (Shanghai) Co., Ltd.**

Unit 205, AZIA Center, No.133 Yincheng Rd (n), Pudong District, Shanghai 200120, China  
Tel: <86> (21) 5877-1818, Fax: <86> (21) 6887-7898

**Renesas Technology Hong Kong Ltd.**

7th Floor, North Tower, World Finance Centre, Harbour City, 1 Canton Road, Tsimshatsui, Kowloon, Hong Kong  
Tel: <852> 2265-6688, Fax: <852> 2730-6071

**Renesas Technology Taiwan Co., Ltd.**

10th Floor, No.99, Fushing North Road, Taipei, Taiwan  
Tel: <886> (2) 2715-2888, Fax: <886> (2) 2713-2999

**Renesas Technology Singapore Pte. Ltd.**

1 Harbour Front Avenue, #06-10, Keppel Bay Tower, Singapore 098632  
Tel: <65> 6213-0200, Fax: <65> 6278-8001

**Renesas Technology Korea Co., Ltd.**

Kukje Center Bldg. 18th Fl., 191, 2-ka, Hangang-ro, Yongsan-ku, Seoul 140-702, Korea  
Tel: <82> (2) 796-3115, Fax: <82> (2) 796-2145

**Renesas Technology Malaysia Sdn. Bhd**

Unit 906, Block B, Menara Amcorp, Amcorp Trade Centre, No.18, Jalan Persiaran Barat, 46050 Petaling Jaya, Selangor Darul Ehsan, Malaysia  
Tel: <603> 7955-9390, Fax: <603> 7955-9510



# Mouser Electronics

Authorized Distributor

Click to View Pricing, Inventory, Delivery & Lifecycle Information:

## Renesas Electronics:

[R5F21162SP#U0](#) [R5F21174SP#U0](#) [R5F21174DSP#U0](#) [R5F21164SP#U0](#) [R5F21164DSP#U0](#) [R5F21172SP#U0](#)  
[R5F21163SP#U0](#)



Компания «ЭлектроПласт» предлагает заключение долгосрочных отношений при поставках импортных электронных компонентов на взаимовыгодных условиях!

Наши преимущества:

- Оперативные поставки широкого спектра электронных компонентов отечественного и импортного производства напрямую от производителей и с крупнейших мировых складов;
- Поставка более 17-ти миллионов наименований электронных компонентов;
- Поставка сложных, дефицитных, либо снятых с производства позиций;
- Оперативные сроки поставки под заказ (от 5 рабочих дней);
- Экспресс доставка в любую точку России;
- Техническая поддержка проекта, помощь в подборе аналогов, поставка прототипов;
- Система менеджмента качества сертифицирована по Международному стандарту ISO 9001;
- Лицензия ФСБ на осуществление работ с использованием сведений, составляющих государственную тайну;
- Поставка специализированных компонентов (Xilinx, Altera, Analog Devices, Intersil, Interpoint, Microsemi, Aeroflex, Peregrine, Syfer, Eurofarad, Texas Instrument, Miteq, Cobham, E2V, MA-COM, Hittite, Mini-Circuits, General Dynamics и др.);

Помимо этого, одним из направлений компании «ЭлектроПласт» является направление «Источники питания». Мы предлагаем Вам помощь Конструкторского отдела:

- Подбор оптимального решения, техническое обоснование при выборе компонента;
- Подбор аналогов;
- Консультации по применению компонента;
- Поставка образцов и прототипов;
- Техническая поддержка проекта;
- Защита от снятия компонента с производства.



#### Как с нами связаться

**Телефон:** 8 (812) 309 58 32 (многоканальный)

**Факс:** 8 (812) 320-02-42

**Электронная почта:** [org@eplast1.ru](mailto:org@eplast1.ru)

**Адрес:** 198099, г. Санкт-Петербург, ул. Калинина, дом 2, корпус 4, литера А.