

EVB72036

868/915MHz FSK/ASK Transmitter

Evaluation Board Description

Features

- Fully integrated PLL-stabilized VCO
- Frequency range from 850 MHz to 930 MHz
- Single-ended RF output
- FSK through crystal pulling allows modulation from DC to 40 kbit/s
- High FSK deviation possible for wideband data transmission
- ASK achieved by on/off keying of internal
- power amplifier up to 40 kbit/s
- Wide power supply range from 1.95 V to 5.5 V
- Very low standby current
- Microcontroller clock output
- On-chip low voltage detector
- High over-all frequency accuracy
- FSK deviation and center frequency independently adjustable
- Adjustable output power range from -11 dBm to +9.5 dBm
- Adjustable current consumption from 5.5 mA to 13.8 mA
- Conforms to EN 300 220 and similar standards

Application Examples

- General digital data transmission
- Tire Pressure Monitoring Systems (TPMS)
- Remote Keyless Entry (RKE)
- Wireless access control
- Alarm and security systems
- Garage door openers
- Remote Controls
- Home and building automation
- Low-power telemetry systems

Evaluation board example

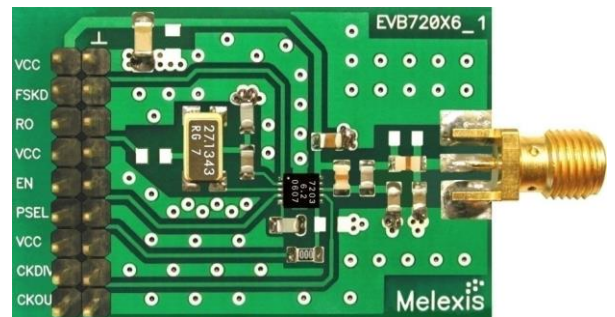

Ordering information

Part No. (see paragraph 5)

EVB72036-868-FSK-C

EVB72036-915-FSK-C

Note: EVB default population is FSK, ASK modification according to section 3.1.

General Description

The TH72036 evaluation board is designed to demonstrate the performance of the transmitter IC for conductive measurements. The power amplifier is matched to 50 Ohms by means of a π -matching network to operate at a resonant frequency of 868 and 915 MHz.

The EVB72036 also features a clock output applicable to drive a microcontroller. The clock frequency can be selected by an external logic signal.

Contents

| | |
|--|-----------|
| Features | 1 |
| Application Examples | 1 |
| Evaluation board example..... | 1 |
| Ordering information | 1 |
| General Description | 1 |
| Contents | 2 |
| 1. Theory of Operation..... | 3 |
| 1.1. General..... | 3 |
| 1.2. Block Diagram..... | 3 |
| 2. Functional Description | 3 |
| 2.1. Crystal Oscillator..... | 3 |
| 2.2. FSK Modulation | 4 |
| 2.3. Crystal Pulling | 4 |
| 2.4. ASK Modulation | 5 |
| 2.5. Output Power Selection | 5 |
| 2.6. Lock Detection..... | 5 |
| 2.7. Low Voltage Detection..... | 5 |
| 2.8. Mode Control Logic | 6 |
| 2.9. Clock Output..... | 6 |
| 2.10. Timing Diagrams..... | 6 |
| 3. 50Ω Connector Board Circuit Diagram..... | 7 |
| 3.1. Board Component Values | 7 |
| 3.2. 50Ω Connector Board PCB Top View | 8 |
| 3.3. Board Connection..... | 8 |
| 4. Evaluation Board Layout..... | 9 |
| 5. Board Variants..... | 9 |
| 6. Package Description | 10 |
| 6.1. Soldering Information | 10 |
| 6.2. Recommended PCB Footprints..... | 10 |
| 7. Your Notes | 11 |
| 8. Contact..... | 12 |
| 9. Disclaimer | 12 |

1. Theory of Operation

1.1. General

As depicted in Fig.1, the TH72036 transmitter consists of a fully integrated voltage-controlled oscillator (VCO), a divide-by-32 divider (div32), a phase-frequency detector (PFD) and a charge pump (CP). An internal loop filter determines the dynamic behavior of the PLL and suppresses reference spurious signals. A Colpitts crystal oscillator (XOSC) is used as the reference oscillator of a phase-locked loop (PLL) synthesizer. The VCO's output signal feeds the power amplifier (PA). The RF signal power P_{out} can be adjusted in four steps from $P_{out} = -11$ dBm to +9.5 dBm, either by changing the value of resistor RPS or by varying the voltage V_{ps} at pin PSEL. The open-collector output (OUT) can be used either to directly drive a loop antenna or to be matched to a 50Ohm load. Bandgap biasing ensures stable operation of the IC at a power supply range of 1.95 V to 5.5 V.

1.2. Block Diagram

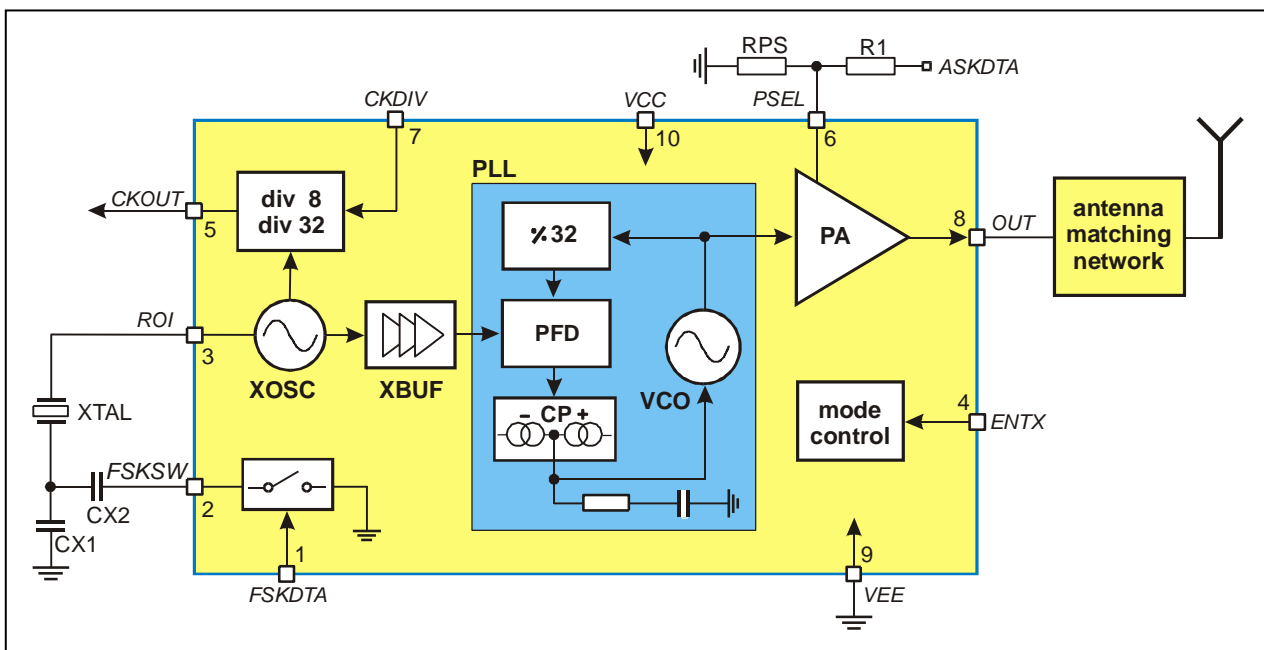

Fig. 1: Block diagram with external components

2. Functional Description

2.1. Crystal Oscillator

A Colpitts crystal oscillator with integrated functional capacitors is used as the reference oscillator for the PLL synthesizer. The equivalent input capacitance CRO offered by the crystal oscillator input pin ROI is about 18pF. The crystal oscillator is provided with an amplitude control loop in order to have a very stable frequency over the specified supply voltage and temperature range in combination with a short start-up time.

2.2. FSK Modulation

FSK modulation can be achieved by pulling the crystal oscillator frequency. A CMOS-compatible data stream applied at the pin FSKDTA digitally modulates the XOSC via an integrated NMOS switch. Two external pulling capacitors CX1 and CX2 allow the FSK deviation Δf and the center frequency f_c to be adjusted independently. At FSKDTA = 0, CX2 is connected in parallel to CX1 leading to the low-frequency component of the FSK spectrum (f_{min}); while at FSKDTA = 1, CX2 is deactivated and the XOSC is set to its high frequency f_{max} .

An external reference signal can be directly AC-coupled to the reference oscillator input pin ROI. Then the transmitter is used without a crystal. Now the reference signal sets the carrier frequency and may also contain the FSK (or FM) modulation.

Fig. 2: Crystal pulling circuitry

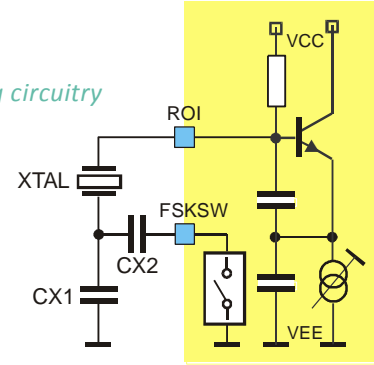

| FSKDTA | Description |
|--------|---|
| 0 | $f_{min} = f_c - \Delta f$ (FSK switch is closed) |
| 1 | $f_{max} = f_c + \Delta f$ (FSK switch is open) |

2.3. Crystal Pulling

A crystal is tuned by the manufacturer to the required oscillation frequency f_0 at a given load capacitance CL and within the specified calibration tolerance. The only way to pull the oscillation frequency is to vary the effective load capacitance CL_{eff} seen by the crystal.

Figure 3 shows the oscillation frequency of a crystal as a function of the effective load capacitance. This capacitance changes in accordance with the logic level of FSKDTA around the specified load capacitance. The figure illustrates the relationship between the external pulling capacitors and the frequency deviation.

It can also be seen that the pulling sensitivity increases with the reduction of CL. Therefore, applications with a high frequency deviation require a low load capacitance. For narrow band FSK applications, a higher load capacitance could be chosen in order to reduce the frequency drift caused by the tolerances of the chip and the external pulling capacitors.

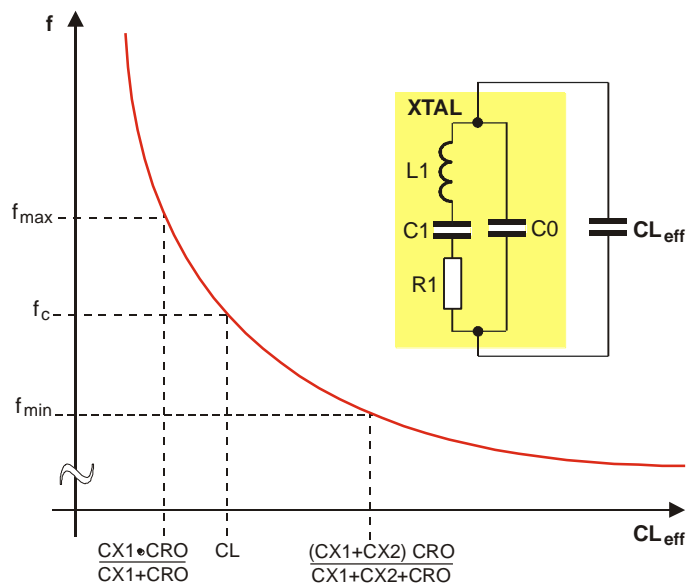

Fig. 3: Crystal pulling characteristic

For ASK applications CX2 can be omitted. Then CX1 has to be adjusted for center frequency.

2.4. ASK Modulation

The TH72036 can be ASK-modulated by applying data directly at pin PSEL. This turns the PA on and off which leads to an ASK signal at the output.

2.5. Output Power Selection

The transmitter is provided with an output power selection feature. There are four predefined output power steps and one off-step accessible via the power selection pin PSEL. A digital power step adjustment was chosen because of its high accuracy and stability. The number of steps and the step sizes as well as the corresponding power levels are selected to cover a wide spectrum of different applications.

The implementation of the output power control logic is shown in figure 4. There are two matched current sources with an amount of about 8 μA . One current source is directly applied to the PSEL pin. The other current source is used for the generation of reference voltages with a resistor ladder. These reference voltages are defining the thresholds between the power steps. The four comparators deliver thermometer-coded control signals depending on the voltage level at the pin PSEL. In order to have a certain amount of ripple tolerance in a noisy environment the comparators are provided with a little hysteresis of about 20 mV. With these control signals, weighted current sources of the power amplifier are switched on or off to set the desired output power level (Digitally Controlled Current Source). The LOCK, ASK signal and the output of the low voltage detector are gating this current source.

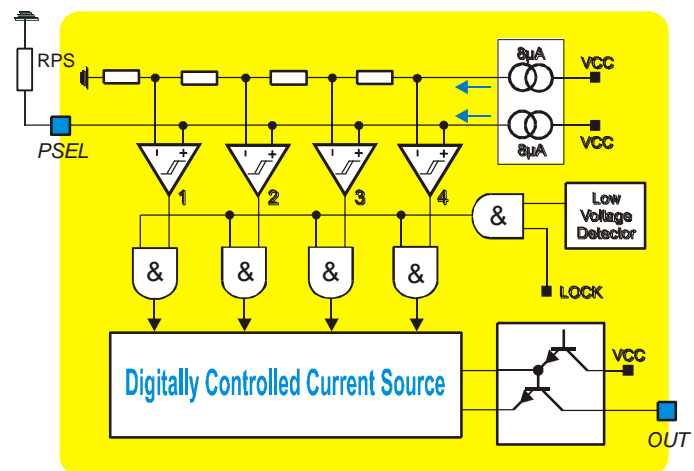

Fig. 4: Block diagram of output power control circuitry

There are two ways to select the desired output power step. First by applying a DC voltage at the pin PSEL, then this voltage directly selects the desired output power step. This kind of power selection can be used if the transmission power must be changed during operation. For a fixed-power application a resistor can be used which is connected from the PSEL pin to ground. The voltage drop across this resistor selects the desired output power level. For fixed-power applications at the highest power step this resistor can be omitted. The pin PSEL is in a high impedance state during the "TX standby" mode.

2.6. Lock Detection

The lock detection circuitry turns on the power amplifier only after PLL lock. This prevents from unwanted emission of the transmitter if the PLL is unlocked.

2.7. Low Voltage Detection

The supply voltage is sensed by a low voltage detect circuitry. The power amplifier is turned off if the supply voltage drops below a value of about 1.85 V. This is done in order to prevent unwanted emission of the transmitter if the supply voltage is too low.

2.8. Mode Control Logic

The mode control logic allows two different modes of operation as listed in the following table. The mode control pin EN is pulled-down internally. This guarantees that the whole circuit is shut down if this pin is left floating.

| EN | Mode | Description |
|----|---------------------------|--------------------|
| 0 | TX standby | TX disabled |
| 1 | TX active CKOUT active | TX / CKOUT enabled |

2.9. Clock Output

The clock output CKOUT is CMOS-compatible and can be used to drive a microcontroller. The frequency of the clock can be changed by the clock divider control signal CKDIV, that can be selected according to the following table. A capacitor at pin CKOUT can be used to control the clock voltage swing and the spurious emission.

| CKDIV | Clock divider ratio | Clock frequency / $f_c=433.92$ MHz |
|-------|---------------------|------------------------------------|
| 0 | 4 | 3.39 MHz |
| 1 | 16 | 848 kHz |

2.10. Timing Diagrams

After enabling the transmitter by the EN signal, the power amplifier remains inactive for the time t_{on} , the transmitter start-up time. The crystal oscillator starts oscillation and the PLL locks to the desired output frequency within the time duration t_{on} . After successful PLL lock, the LOCK signal turns on the power amplifier, and then the RF carrier can be FSK or ASK modulated.

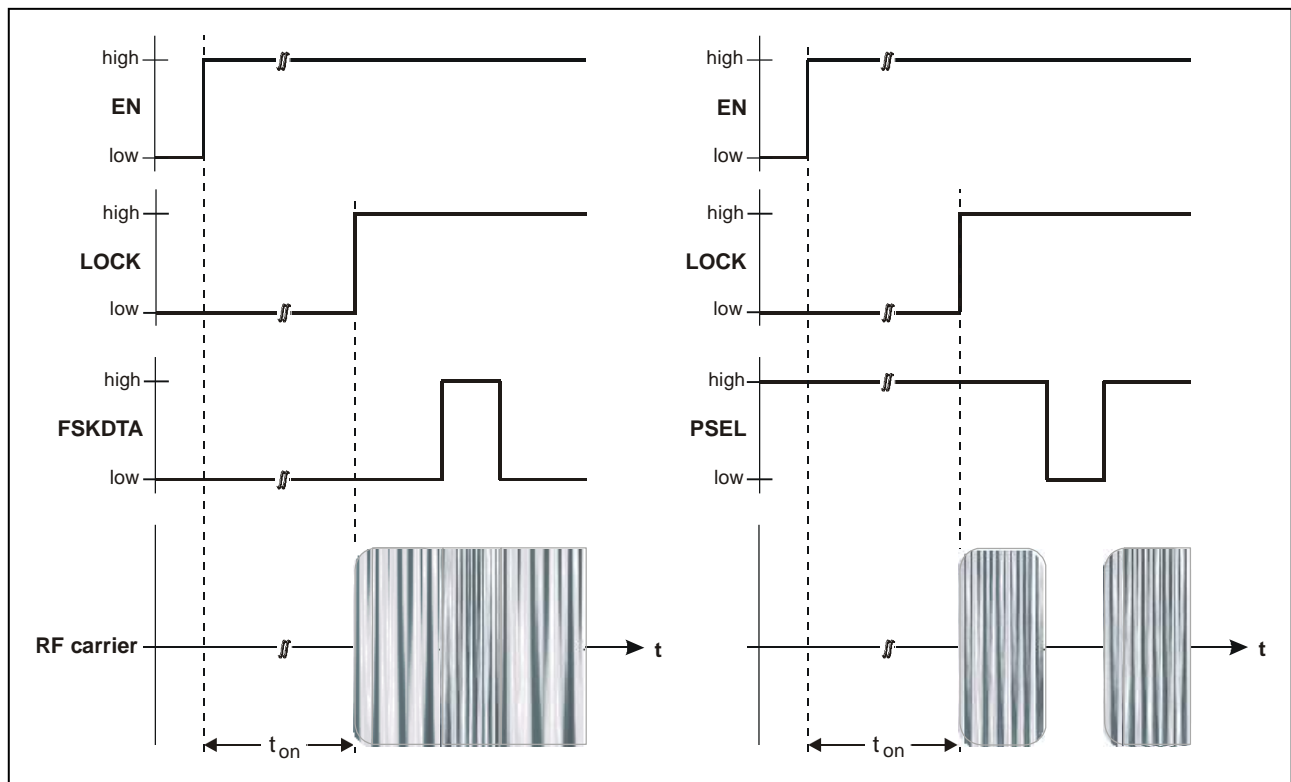

Fig. 5: Timing diagrams for FSK and ASK modulation

For more detailed information, please refer to the latest TH72036 data sheet revision.

3. 50Ω Connector Board Circuit Diagram

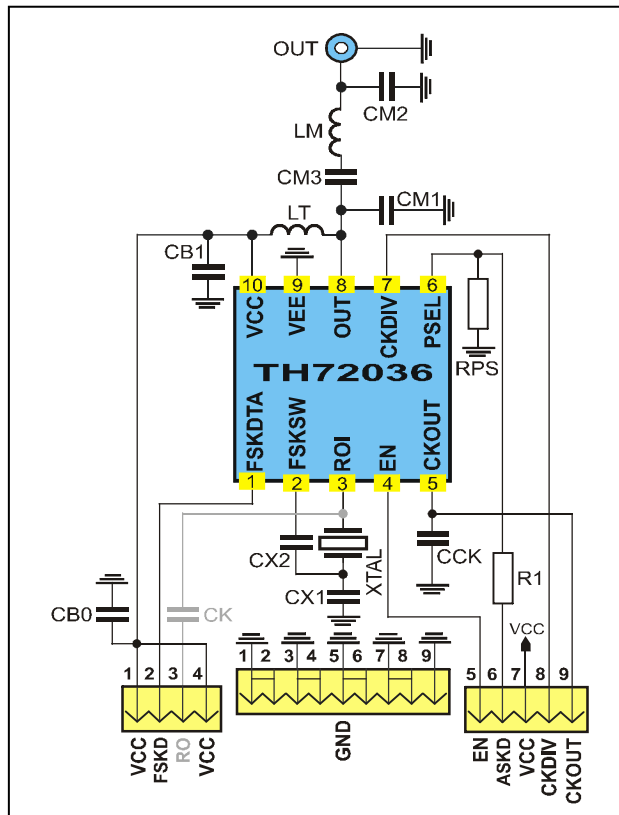

Fig. 6: Circuit diagram with 50 Ω matching network

3.1. Board Component Values

| Part | Size | Value @ 868.3 MHz | Value @ 915 MHz | Tolerance | Description |
|--------------------|-----------|---------------------------|-----------------|-----------|--|
| CM1 | 0805 | 1.8 pF | 2.2 pF | ±5% | impedance matching capacitor |
| CM2 | 0805 | 5.6 pF | 5.6 pF | ±5% | impedance matching capacitor |
| CM3 | 0805 | 68 pF | 68 pF | ±5% | impedance matching capacitor r |
| LM | 0805 | 12 nH | 10 nH | ±5% | impedance matching inductor |
| LT | 0805 | 15 nH | 10 nH | ±5% | output tank inductor |
| CX1 _{FSK} | 0805 | 22 pF | 22 pF | ±5% | XOSC FSK capacitor ($\Delta f = \pm 20$ kHz), note 1 |
| CX1 _{ASK} | 0805 | 27 pF | 27 pF | ±5% | XOSC ASK capacitor, trimmed to f_c , note 1 |
| CX2 | 0805 | 12pF | 12 pF | ±5% | XOSC capacitor ($\Delta f = \pm 20$ kHz), note 1, only for FSK |
| CCK | 0805 | 15 pF/ 180 pF | | ±5% | capacitor to control clock voltage swing (CKDIV 0 / 1) |
| RPS | 0805 | NIP | | ±5% | power-select resistor, see data sheet section 4.6 |
| R1 | 0805 | 0 Ω | | ±5% | ASK jumper (for ASK only), see data sheet sect. 4.7 |
| CB0 | 1206 | 220 nF | | ±20% | de-coupling capacitor |
| CB1 | 0805 | 330 pF | | ±10% | de-coupling capacitor |
| XTAL | SMD 6x3.5 | 27.13438 MHz | 28.59375 MHz | | fundamental mode crystal, $C_L = 12$ pF, $C_{0,max} = 7$ pF, $R_1 = 40$ Ω |
| | | ±30ppm cali., ±30ppm temp | | | |
| CK | 0805 | 1 nF | | ±10% | ROI coupling capacitor, only required for external reference frequency input |

Note 1: depends on crystal parameters, other Δf values can be selected with other CX1, CX2 values
NIP – not in place, may be used optionally

EVB72036

868/915MHz FSK/ASK Transmitter

Evaluation Board Description

3.2. 50Ω Connector Board PCB Top View

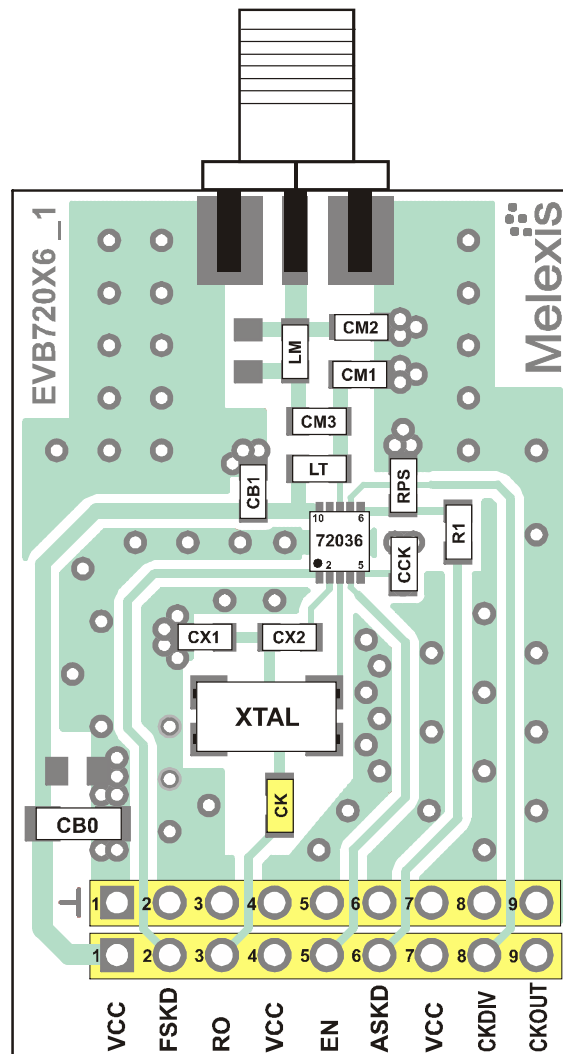

Board size is 27 mm x 42 mm

3.3. Board Connection

| | | | |
|-------------|--|--------------|--|
| VCC | Power supply (1.95 V to 5.5 V) | CKDIV | Clock divider input, (CMOS, see sect. 2.9) |
| FSKD | Input for FSK data (CMOS, see section 2.2) | CKOUT | Clock output, (CMOS, see section 2.9) |
| ASKD | Input for ASK data (CMOS, see section 2.4) | RO | External reference frequency input |
| EN | Mode control pin (see par. 2.8) | ⊥ | Several ground pins |

EVB72036

868/915MHz FSK/ASK Transmitter
Evaluation Board Description

4. Evaluation Board Layout

Board layout data in Gerber format are available, board size is 27mm x 42mm x 1mm FR4.

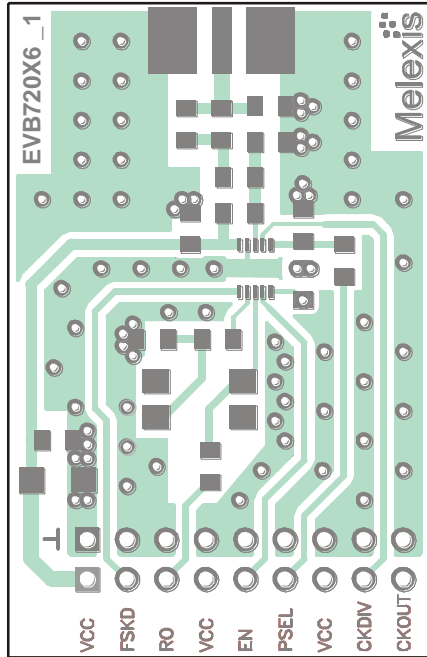

PCB top view

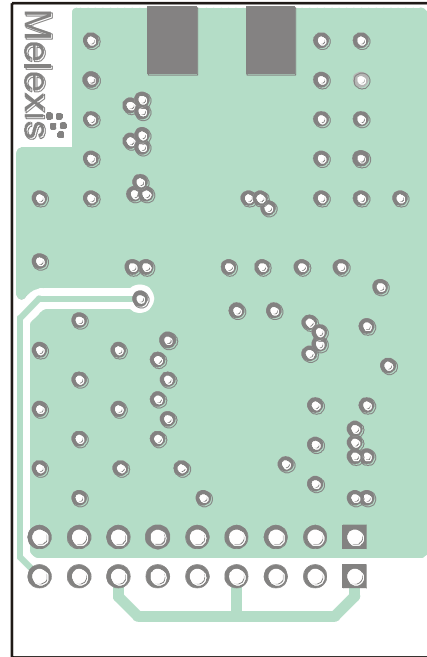

PCB bottom view

5. Board Variants

| Type | Frequency/MHz | Modulation | | Board Execution | |
|-----------------|---------------|------------|-------------|-----------------|-------------------|
| EVB72005 | -315 | | -FSK | -A | antenna version |
| | -433 | | -ASK | -C | connector version |
| | -868 | | -FM | | |
| | -915 | | | | |

Note: available EVB setups

6. Package Description



The device TH72016 is RoHS compliant.

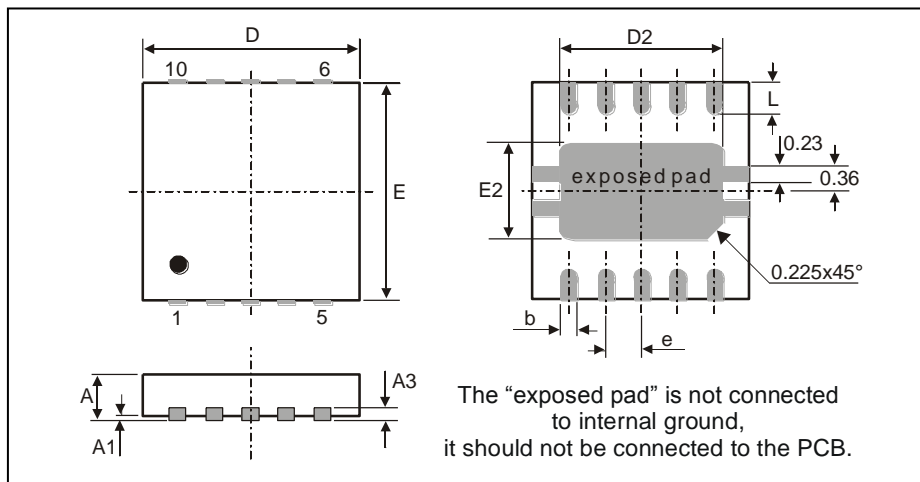

Fig. 7: 10L QFN 3x3 Dual

| all Dimensions in mm | | | | | | | | | | |
|------------------------|-------|-------|--------|-------|--------|-------|--------|--------|--------|--------|
| | D | E | D2 | E2 | A | A1 | A3 | L | e | b |
| min | 2.85 | 2.85 | 2.23 | 1.49 | 0.80 | 0 | 0.20 | 0.3 | 0.50 | 0.18 |
| max | 3.15 | 3.15 | 2.48 | 1.74 | 1.00 | 0.05 | | 0.5 | | 0.30 |
| all Dimensions in inch | | | | | | | | | | |
| min | 0.112 | 0.112 | 0.0878 | 0.051 | 0.0315 | 0 | 0.0079 | 0.0118 | 0.0197 | 0.0071 |
| max | 0.124 | 0.124 | 0.0976 | 0.055 | 0.0393 | 0.002 | | 0.0197 | | 0.0118 |

6.1. Soldering Information

- The device TH72036 is qualified for MSL3 with soldering peak temperature 260 deg C according to JEDEC J-STD-20

6.2. Recommended PCB Footprints

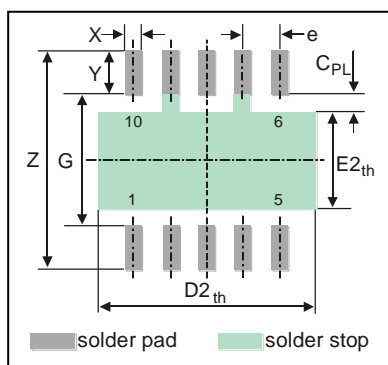

| all Dimensions in mm | | | | | | | | |
|------------------------|--------|--------|------------------|------------------|--------|--------|-----------------|--------|
| | Z | G | D2 _{th} | E2 _{th} | X | Y | C _{PL} | e |
| min | 3.55 | 1.9 | 3.2 | 1.3 | 0.25 | 0.7 | 0.3 | 0.5 |
| max | 3.90 | 2.3 | 3.6 | 1.7 | 0.30 | 1.0 | 0.5 | |
| all Dimensions in inch | | | | | | | | |
| min | 0.1398 | 0.0748 | 0.1260 | 0.0512 | 0.0098 | 0.0276 | 0.0591 | 0.0197 |
| max | 0.1535 | 0.0906 | 0.1417 | 0.0669 | 0.0118 | 0.0394 | 0.0197 | |

Fig. 8: PCB land pattern style

EVB72036

868/915MHz FSK/ASK Transmitter
Evaluation Board Description

7. Your Notes

8. Contact

For the latest version of this document, go to our website at www.melexis.com.

For additional information, please contact our Direct Sales team and get help for your specific needs:

| | |
|----------------|----------------------------------|
| Europe, Africa | Telephone: +32 13 67 04 95 |
| | Email : sales_europe@melexis.com |
| Americas | Telephone: +1 603 223 2362 |
| | Email : sales_usa@melexis.com |
| Asia | Email : sales_asia@melexis.com |

9. Disclaimer

The information furnished by Melexis herein ("Information") is believed to be correct and accurate. Melexis disclaims (i) any and all liability in connection with or arising out of the furnishing, performance or use of the technical data or use of the product(s) as described herein ("Product") (ii) any and all liability, including without limitation, special, consequential or incidental damages, and (iii) any and all warranties, express, statutory, implied, or by description, including warranties of fitness for particular purpose, non-infringement and merchantability. No obligation or liability shall arise or flow out of Melexis' rendering of technical or other services.

The Information is provided "as is" and Melexis reserves the right to change the Information at any time and without notice. Therefore, before placing orders and/or prior to designing the Product into a system, users or any third party should obtain the latest version of the relevant information to verify that the information being relied upon is current. Users or any third party must further determine the suitability of the Product for its application, including the level of reliability required and determine whether it is fit for a particular purpose.

The Information is proprietary and/or confidential information of Melexis and the use thereof or anything described by the Information does not grant, explicitly or implicitly, to any party any patent rights, licenses, or any other intellectual property rights.

This document as well as the Product(s) may be subject to export control regulations. Please be aware that export might require a prior authorization from competent authorities.

The Product(s) are intended for use in normal commercial applications. Unless otherwise agreed upon in writing, the Product(s) are not designed, authorized or warranted to be suitable in applications requiring extended temperature range and/or unusual environmental requirements. High reliability applications, such as medical life-support or life-sustaining equipment are specifically not recommended by Melexis.

The Product(s) may not be used for the following applications subject to export control regulations: the development, production, processing, operation, maintenance, storage, recognition or proliferation of 1) chemical, biological or nuclear weapons, or for the development, production, maintenance or storage of missiles for such weapons; 2) civil firearms, including spare parts or ammunition for such arms; 3) defense related products, or other material for military use or for law enforcement; 4) any applications that, alone or in combination with other goods, substances or organisms could cause serious harm to persons or goods and that can be used as a means of violence in an armed conflict or any similar violent situation.

The Products sold by Melexis are subject to the terms and conditions as specified in the Terms of Sale, which can be found at <https://www.melexis.com/en/legal/terms-and-conditions>.

This document supersedes and replaces all prior information regarding the Product(s) and/or previous versions of this document.

Melexis NV © - No part of this document may be reproduced without the prior written consent of Melexis. (2016)

ISO/TS 16949 and ISO14001 Certified



Компания «ЭлектроПласт» предлагает заключение долгосрочных отношений при поставках импортных электронных компонентов на взаимовыгодных условиях!

Наши преимущества:

- Оперативные поставки широкого спектра электронных компонентов отечественного и импортного производства напрямую от производителей и с крупнейших мировых складов;
- Поставка более 17-ти миллионов наименований электронных компонентов;
- Поставка сложных, дефицитных, либо снятых с производства позиций;
- Оперативные сроки поставки под заказ (от 5 рабочих дней);
- Экспресс доставка в любую точку России;
- Техническая поддержка проекта, помощь в подборе аналогов, поставка прототипов;
- Система менеджмента качества сертифицирована по Международному стандарту ISO 9001;
- Лицензия ФСБ на осуществление работ с использованием сведений, составляющих государственную тайну;
- Поставка специализированных компонентов (Xilinx, Altera, Analog Devices, Intersil, Interpoint, Microsemi, Aeroflex, Peregrine, Syfer, Eurofarad, Texas Instrument, Miteq, Cobham, E2V, MA-COM, Hittite, Mini-Circuits, General Dynamics и др.);

Помимо этого, одним из направлений компании «ЭлектроПласт» является направление «Источники питания». Мы предлагаем Вам помощь Конструкторского отдела:

- Подбор оптимального решения, техническое обоснование при выборе компонента;
- Подбор аналогов;
- Консультации по применению компонента;
- Поставка образцов и прототипов;
- Техническая поддержка проекта;
- Защита от снятия компонента с производства.



Как с нами связаться

Телефон: 8 (812) 309 58 32 (многоканальный)

Факс: 8 (812) 320-02-42

Электронная почта: org@eplast1.ru

Адрес: 198099, г. Санкт-Петербург, ул. Калинина, дом 2, корпус 4, литера А.