

**PLEASE CHECK WWW.MOLEX.COM FOR LATEST PART INFORMATION**

**Part Number:** [0524353071](#)  
**Status:** **Active**  
**Overview:**  
**Description:** 0.50mm (.020") Pitch SMT Right-Angle FFC/FPC Connector, 30 Circuits, Gold (Au) Contact Plating

**General**

Product Family FFC/FPC Connectors  
 Series 52435  
 Overview ffc\_fpc\_smt  
 Product Name N/A

**Physical**

Circuits (Loaded) 30  
 Contact Position Top  
 Durability (mating cycles max) 20  
 Entry Angle 90° Angle  
 Mated Height (in) 0.079 In  
 Mated Height (mm) 2.00 mm  
 Material - Metal Phosphor Bronze  
 Material - Plating Mating Gold  
 Material - Plating Termination Gold  
 Material - Resin Nylon  
 Number of Rows 1  
 Orientation Right Angle  
 PCB Locator No  
 PCB Retention Yes  
 Packaging Type Embossed Tape on Reel  
 Pitch - Mating Interface (in) 0.020 In  
 Pitch - Mating Interface (mm) 0.50 mm  
 Polarized to PCB Yes  
 Stackable No  
 Temperature Range - Operating -40°C to +85°C  
 Termination Interface: Style Surface Mount  
 Wire/Cable Type FFC/FPC

**Electrical**

Current - Maximum per Contact 0.5A  
 Voltage - Maximum 50V AC (RMS)/DC

**Material Info**

**Reference - Drawing Numbers**

Packaging Specification SPK-52435-001  
 Product Specification PS-52435-025, RPS-52435-036, RPS-52435-039, RPS-52435-040, RPS-52435-042, RPS-52435-043, RPS-52435-045, RPS-52435-046, RPS-52435-048  
 Sales Drawing SD-52435-016, SD-52435-017

**EU RoHS**

**ELV and RoHS Compliant**

**REACH SVHC**

Not Reviewed

**Halogen-Free**

**Status**

**Not Reviewed**

**China RoHS**



**Need more information on product environmental compliance?**

Email [productcompliance@molex.com](mailto:productcompliance@molex.com)  
 For a multiple part number RoHS Certificate of Compliance, [click here](#)

Please visit the [Contact Us](#) section for any non-product compliance questions.

**Search Parts in this Series**

[52435Series](#)

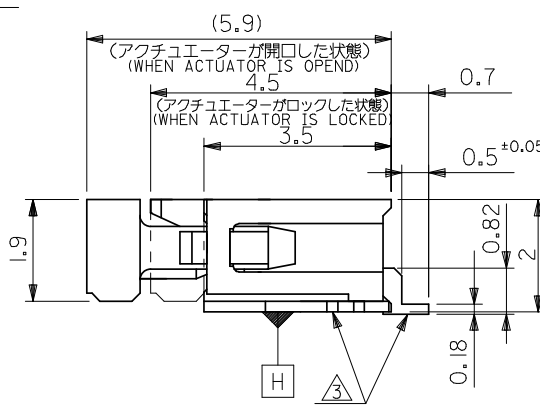
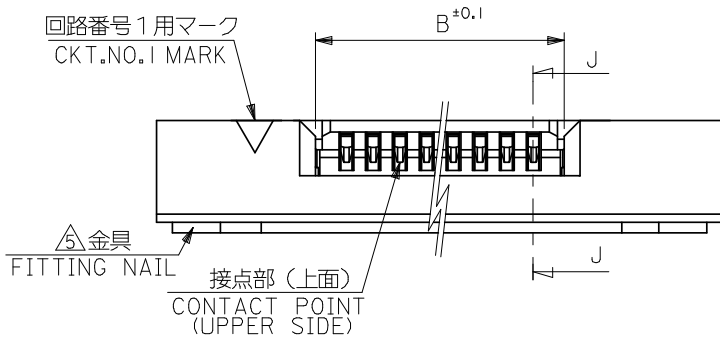
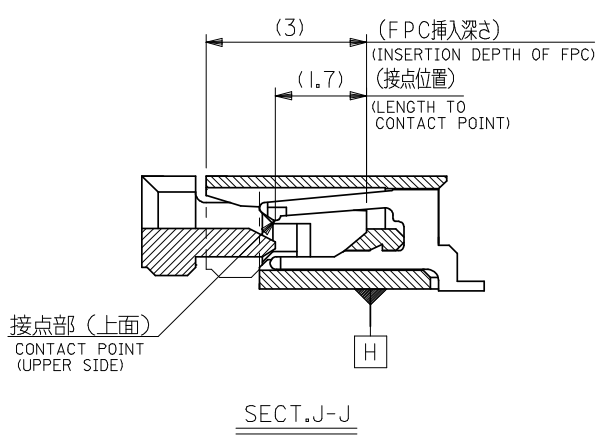
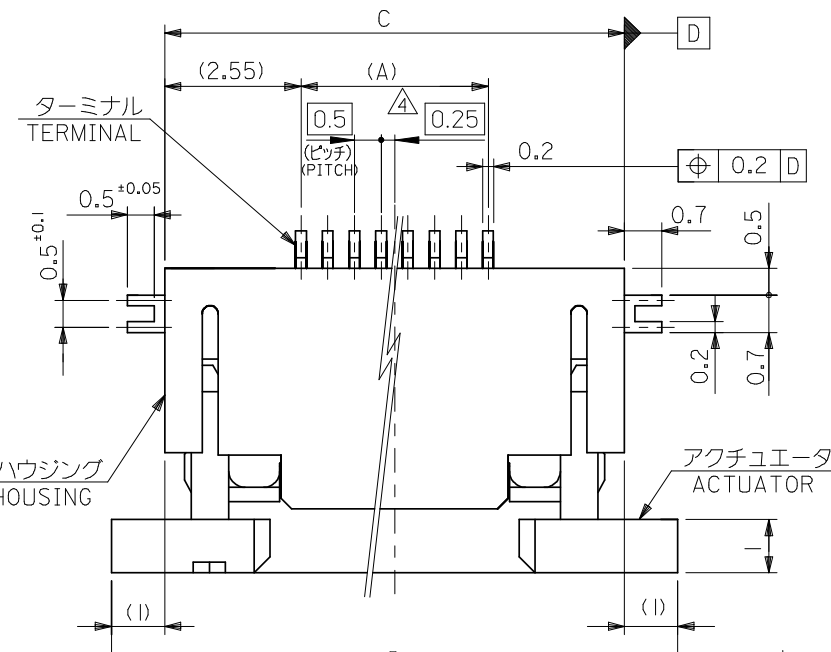

21.6	19.6	15.65	14.5	52435-3071	52435-3029	30
21.1	19.1	15.15	14.0	52435-2971	52435-2929	29
20.6	18.6	14.65	13.5	52435-2871	52435-2829	28
20.1	18.1	14.15	13.0	52435-2771	52435-2729	27
19.6	17.6	13.65	12.5	52435-2671	52435-2629	26
19.1	17.1	13.15	12.0	52435-2571	52435-2529	25
18.6	16.6	12.65	11.5	52435-2471	52435-2429	24
18.1	16.1	12.15	11.0	52435-2371	52435-2329	23
17.6	15.6	11.65	10.5	52435-2271	52435-2229	22
17.1	15.1	11.15	10.0	52435-2171	52435-2129	21
14.6	12.6	8.65	7.5	52435-1671	52435-1629	16
D	C	B	(A)	EMBOSSED TAPE ORDER No. オーダー番号	MATERIAL NO.	極数 CKT.

REVISED EC NO: J2008-4048 DRWN: MNABEL 2008/06/13 CH'KD: THARUYAMA 2008/06/16 APPR: INUKITA 2008/06/16	GENERAL TOLERANCES (UNLESS SPECIFIED)		DIMENSION STYLE MM ONLY		SCALE 10:1	DESIGN UNITS METRIC	MODEL NO. 52435-***29
	10 UNDER	±0.2	DRAWN BY M.UMEDA	DATE 2005/01/17	TITLE 0.5 FPC CONN. ZIF FOR SMT R/A(TOP CONTACT) -LAED FREE-		
	10 OVER 30 UNDER	±0.25	CHECKED BY K. TOYODA	DATE 2005/01/17	THIRD ANGLE PROJECTION		
	30 OVER	±0.3	APPROVED BY N. UKITA	DATE 2005/01/17	MOLEX INCORPORATED		
	ANGULAR	±3°	MATERIAL NO.	DOCUMENT NO. SD-52435-016	SHEET NO. 1 OF 2		
DRAFT WHERE APPLICABLE MUST REMAIN WITHIN DIMENSIONS		SEE TABLE		THIS DRAWING CONTAINS INFORMATION THAT IS PROPRIETARY TO MOLEX INCORPORATED AND SHOULD NOT BE USED WITHOUT WRITTEN PERMISSION			

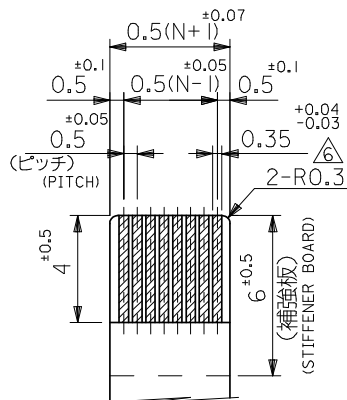

適合FPC推奨寸法  
 APPLICABLE FPC  
 RECOMMENDED DIMENSION.  
 (仕上がり厚さ: 0.3<sup>±0.05</sup>)  
 (THICKNESS: 0.3<sup>±0.05</sup>)

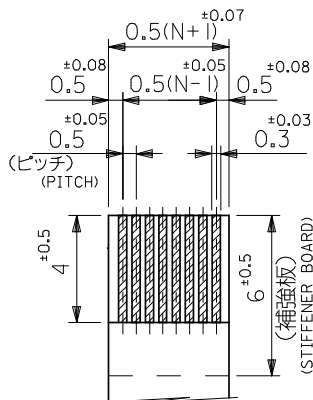

適合FPC推奨寸法  
 APPLICABLE FPC  
 RECOMMENDED DIMENSION.  
 (仕上がり厚さ: 0.3<sup>±0.05</sup>)  
 (THICKNESS: 0.3<sup>±0.05</sup>)

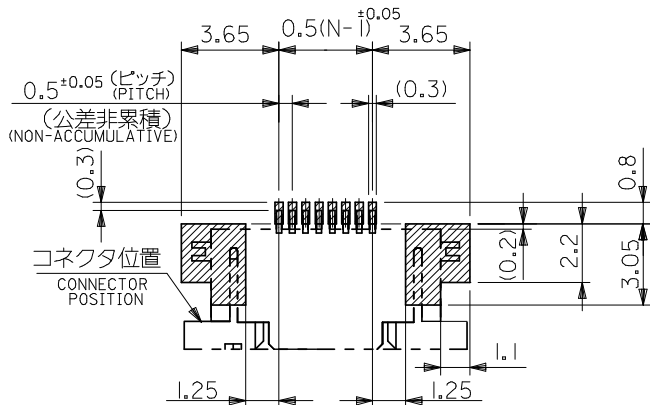

参考基板レイアウト  
 (マウント面)  
 RECOMMENDED P.C. BOARD  
 PATTERN DIMENSION (REF.)  
 (MOUNTING SIDE)

注記 NOTES

1. 使用材料: MATERIAL

ハウジング : 46ナイロン, UL94V-0  
 HOUSING : 46NYLON

アクチュエータ : PPS, UL94V-0  
 ACTUATOR

ターミナル : リン青銅, 金メッキ (t=0.2)  
 TERMINAL : PHOS-BRO.GOLD PLATED

金具 : リン青銅, 錫メッキ (t=0.2)  
 FITTING NAIL : PHOS-BRO.TIN PLATED

2. エンボステーブ梱包時は、アクチュエータがロックした状態とする。  
 IN THE PACKAGE, ACTUATOR OF PART NO.52435-\*\*27 SHOULD BE LOCKED.

△ ソルダータール半田付け面のズレ量、及び金具半田付け面のズレ量は、基準面 H に対し上方向 0.1 MAX. , 下方向 0.15 MAX. とし、相互のバラツキ量は 0.1 MAX. とする。

MISALIGNMENT OF SOLDER TAILS AND FITTING NAILS FROM H  
 UPPER DIRECTION: 0.1 MAX. , LOWER DIRECTION: 0.15 MAX.  
 OFFSET BETWEEN UPPER AND LOWER: 0.1 MAX

△ 偶数極に適用。  
 APPLY FOR EVEN CIRCUIT.

△ パターンはくり止め用金具。  
 FITTING NAIL FOR PREVENTION OF PEELING  
 OF P.C.B. PATTERN.

△ R0.3は、FPCの導体部にかからないこと。  
 R0.3 MUST NOT BE OVERLAPPED TO PATTERN  
 OF FPC.

REVISED		EC NO: J2008-4048		GENERAL TOLERANCES (UNLESS SPECIFIED)		DIMENSION STYLE		SCALE		52435-**29		MODEL NO.	
DRWN:MMABEI 2008/06/13		CHKD:THARUYAMA 2008/06/16		APPR:NUKITA 2008/06/16		10 UNDER ±0.2		10:1		DESIGN UNITS METRIC		THIRD ANGLE PROJECTION	
DESCRIPTION		10 OVER 30 UNDER ±0.25		30 OVER ±0.3		DRAWN BY DATE		TITLE		MOLEX INCORPORATED		SHEET NO.	
REV		ANGULAR ±3 °		DRAFT WHERE APPLICABLE MUST REMAIN WITHIN DIMENSIONS		M. UMEDA 2005/01/17		0.5 FPC CONN. ZIF FOR SMT R/A(TOP CONTACT) -LAED FREE-		MOLEX INCORPORATED		2 OF 2	
		SEE SHEET 1		MATERIAL NO.		K TOYODA 2005/01/17		MOLEX INCORPORATED		DOCUMENT NO.		SHEET NO.	
		THIS DRAWING CONTAINS INFORMATION THAT IS PROPRIETARY TO MOLEX INCORPORATED AND SHOULD NOT BE USED WITHOUT WRITTEN PERMISSION				N. UKITA 2005/01/17		MOLEX INCORPORATED		SD-52435-016		2 OF 2	

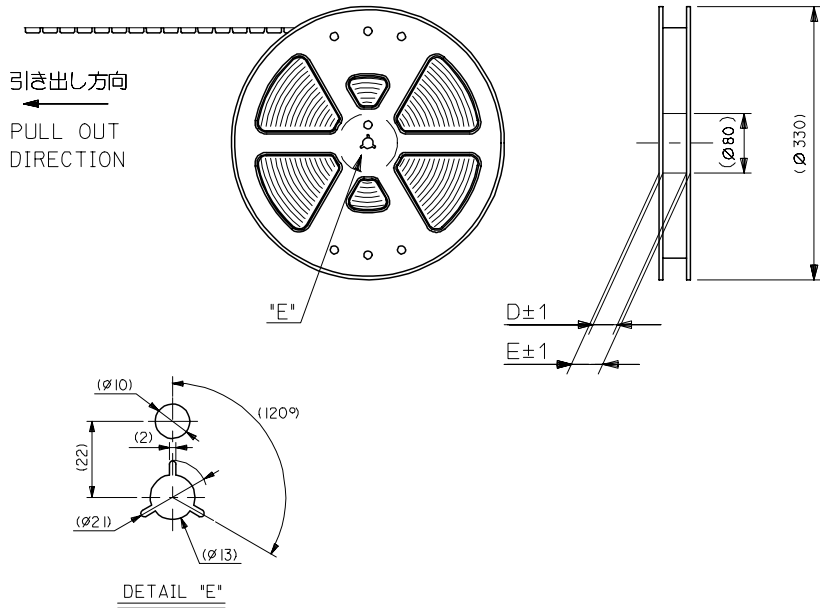

注記 NOTES

- 製品番号 52435-\*\*\*29 の梱包状態はアクチュエータがロックした状態とする。  
 詳細寸法については図面 RSD-52435-027 を参照下さい。  
 IN THE PACKAGE, ACTUATOR OF PART NO. 52435-\*\*\*29 SHOULD BE LOCKED RE DETAILED DIMENSIONS, SEE RSD-52435-027
- 梱包数量：1000個/リール  
 NUMBER OF CONNECTORS: 1000PCS/REEL
- リードテープ長さ LEAD TAPE LENGTH

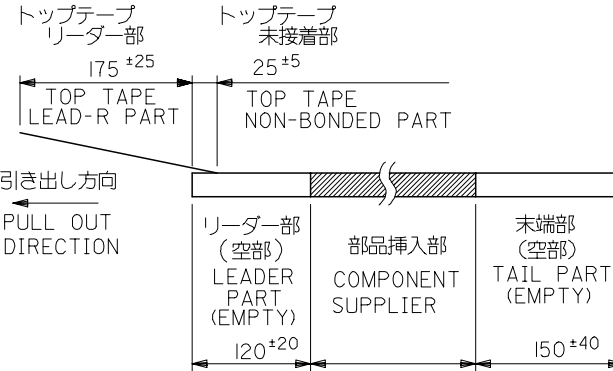

4. 材料 (MATERIAL)

キャリアテープ (CARRIER TAPE): ポリプロピレン (POLYPROPYLENE)  
 トップテープ (TOP TAPE): PET, PE, PEF  
 リール (REEL): ポリスチレン (PS) <リサイクル材を含む>  
 POLYSTYREN (PS) <RECYCLE MATERIAL CONTAINED>

REVISED EC NO: J2006-2753 DRWN: TENAGASE 2006/03/03 CHKD: THARUYAMA 2006/03/10 APPR: NUKITA 2006/03/17	GENERAL TOLERANCES (UNLESS SPECIFIED)		DIMENSION STYLE MM ONLY		SCALE ---	DESIGN UNITS METRIC	THIRD ANGLE PROJECTION	
	10 UNDER	±0.2	DRAWN BY M.UMEDA	DATE 2005/01/17	TITLE 0.5 FPC CONN. ZIF SMT RA WITH TAPE EMBSTP PKG -LEAD FREE-			
	10 OVER 30 UNDER	±0.25	CHECKED BY K.TOYODA	DATE 2005/01/17				
	30 OVER	±0.3	APPROVED BY N.NUKITA	DATE 2005/01/17	MOLEX INCORPORATED MATERIAL NO. 52435-***71 DOCUMENT NO. SD-52435-017 SHEET NO. 1 OF 4			
	ANGULAR	±3 °	DRAFT WHERE APPLICABLE MUST REMAIN WITHIN DIMENSIONS					
REV	DESCRIPTION	SIZE A3		THIS DRAWING CONTAINS INFORMATION THAT IS PROPRIETARY TO MOLEX INCORPORATED AND SHOULD NOT BE USED WITHOUT WRITTEN PERMISSION				

10 9 8 7 6 5 4 3 2 1

24mm幅キャリアテープ  
24mm WIDTH CARRIER TAPE

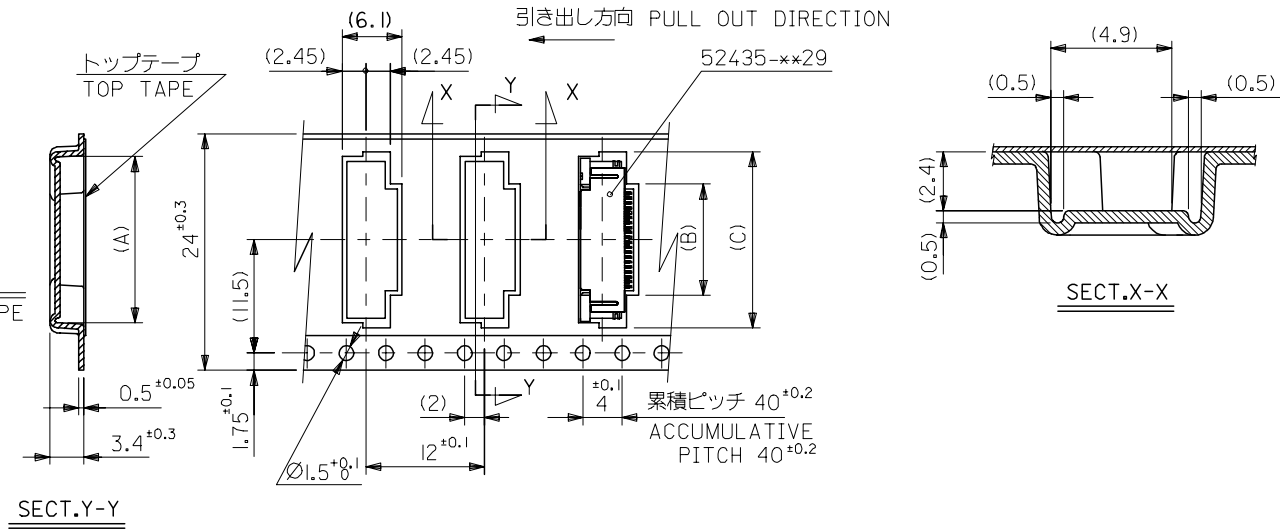

24	29.4	25.4	18.4	11.8	17.4	52435-2171	21
			15.9	9.3	14.9	52435-1671	16
キャリアテープ幅 CARRIER TAPE WIDTH	E	D	(C)	(B)	(A)	MATERIAL NO.	極数 CIRCUIT

REVISED EC NO: J2006-2753 DRWN: TENAGASE 2006/03/03 CHKD: THARUYAMA 2006/03/10 APPR: NUKITA 2006/03/17	GENERAL TOLERANCES (UNLESS SPECIFIED)		DIMENSION STYLE MM ONLY	SCALE ---	DESIGN UNITS METRIC	THIRD ANGLE PROJECTION
	10 UNDER	±0.2	DRAWN BY M.UMEDA	DATE 2005/01/17	TITLE 0.5 FPC CONN. ZIF SMT RA WITH TAPE EMBSTP PKG -LEAD FREE-	
	10 OVER 30 UNDER	±0.25	CHECKED BY K.TOYODA	DATE 2005/01/17	MOLEX INCORPORATED	
	30 OVER	±0.3	APPROVED BY N.NUKITA	DATE 2005/01/17	MATERIAL NO. 52435-**71	
	ANGULAR	±3 °	DOCUMENT NO. SD-52435-017		SHEET NO. 2 OF 4	
	DRAFT WHERE APPLICABLE MUST REMAIN WITHIN DIMENSIONS		THIS DRAWING CONTAINS INFORMATION THAT IS PROPRIETARY TO MOLEX INCORPORATED AND SHOULD NOT BE USED WITHOUT WRITTEN PERMISSION			

10 9 8 7 6 5 4 3 2 1

F

F

E

E

D

D

C

C

B

B

A

A

32mm幅キャリアテープ  
32mm WIDTH CARRIER TAPE

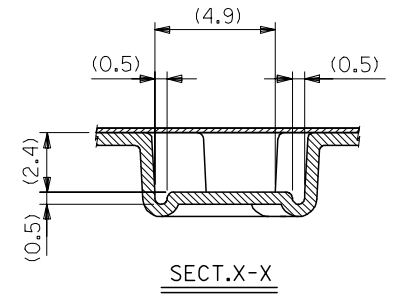
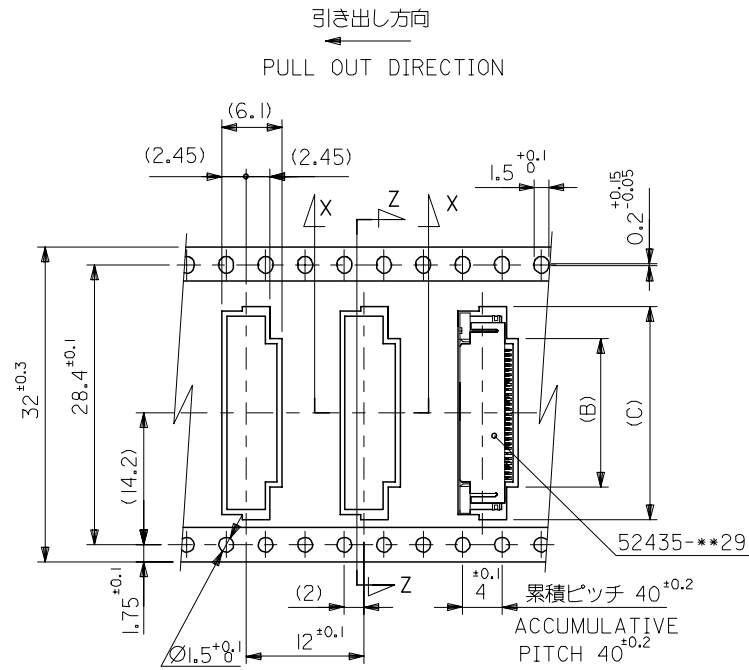
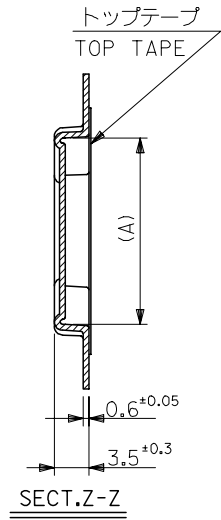

32	37.4	33.4	22.4	15.8	21.4	52435-2971	29
			21.9	15.3	20.9	52435-2871	28
			21.4	14.8	20.4	52435-2771	27
			20.9	14.3	19.9	52435-2671	26
			20.4	13.8	19.4	52435-2571	25
			19.9	13.3	18.9	52435-2471	24
			19.4	12.8	18.4	52435-2371	23
			18.9	12.3	17.9	52435-2271	22

キャリアテープ幅  
CARRIER TAPE WIDTH

E D (C) (B) (A)

MATERIAL NO. 極数 CIRCUIT

REVISED EC NO: J2006-2753 DRWN: TENAGASE 2006/03/03 CHKD: THARYAMA 2006/03/10 APPR: NUKITA 2006/03/17	GENERAL TOLERANCES (UNLESS SPECIFIED)		DIMENSION STYLE MM ONLY	SCALE ---	DESIGN UNITS METRIC	THIRD ANGLE PROJECTION	
	10 UNDER	±0.2	DRAWN BY M.UMEDA	DATE 2005/01/17	TITLE 0.5 FPC CONN. ZIF SMT RA WITH TAPE EMBSTP PKG -LEAD FREE-		
	10 OVER 30 UNDER	±0.25	CHECKED BY K.TOYODA	DATE 2005/01/17	MOLEX INCORPORATED		
	30 OVER	±0.3	APPROVED BY N.NUKITA	DATE 2005/01/17	MATERIAL NO. 52435-**71	DOCUMENT NO. SD-52435-017	SHEET NO. 3 OF 4
	ANGULAR	±3 °	THIS DRAWING CONTAINS INFORMATION THAT IS PROPRIETARY TO MOLEX INCORPORATED AND SHOULD NOT BE USED WITHOUT WRITTEN PERMISSION				
DRAFT WHERE APPLICABLE MUST REMAIN WITHIN DIMENSIONS							

10 9 8 7 6 5 4 3 2 1

F

E

D

C

B

A

F

E

D

C

B

A

引き出し方向  
PULL OUT DIRECTION

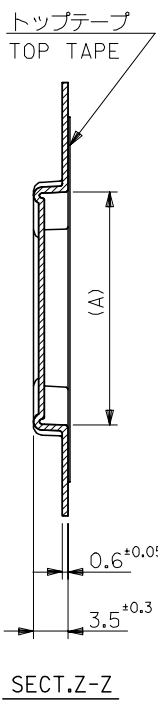

44mm幅キャリアテープ  
44mm WIDTH CARRIER TAPE

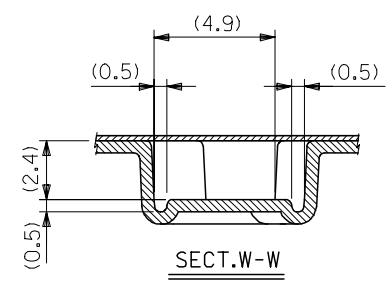
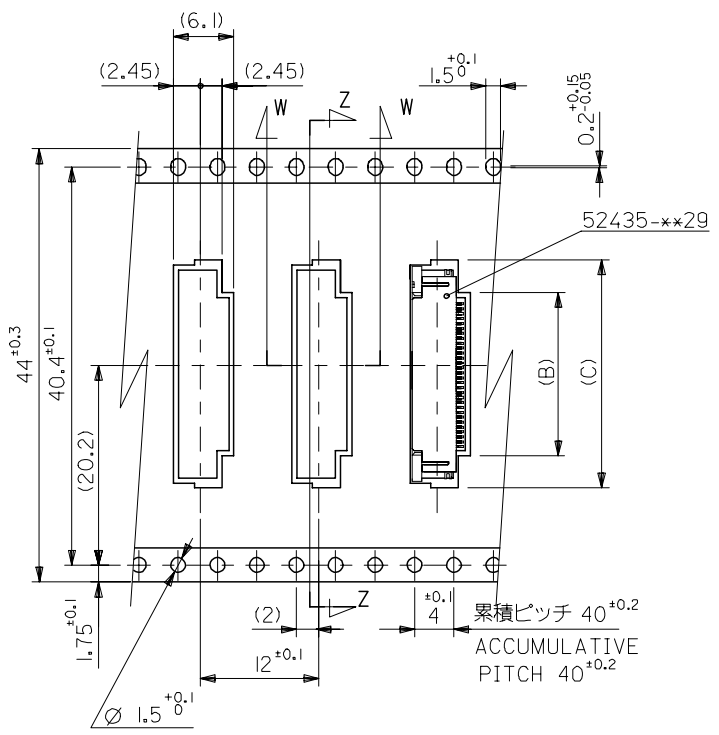

44	49.4	45.4	22.9	16.3	21.9	52435-3071	30
キャリアテープ幅 CARRIER TAPE WIDTH	E	D	(C)	(B)	(A)	MATERIAL NO.	極数 CIRCUIT

REVISED EC NO: J2006-2753 DRWN: TENAGASE 2006/03/03 CHKD: THARUYAMA 2006/03/10 APPR: NUKITA 2006/03/17	GENERAL TOLERANCES (UNLESS SPECIFIED)		DIMENSION STYLE MM ONLY		SCALE ---	DESIGN UNITS METRIC	THIRD ANGLE PROJECTION
	10 UNDER	±0.2	DRAWN BY M.UMEDA	DATE 2005/01/17	TITLE 0.5 FPC CONN ZIF SMT RA WITH TAPE EMBSTP PKG -LEAD FREE- MOLEX INCORPORATED		
	10 OVER 30 UNDER	±0.25	CHECKED BY K.TOYODA	DATE 2005/01/17			
	30 OVER	±0.3	APPROVED BY N. UKITA	DATE 2005/01/17			
	ANGULAR	±3 °	MATERIAL NO. 52435-**71		DOCUMENT NO. SD-52435-017	SHEET NO. 4 OF 4	
DRAFT WHERE APPLICABLE MUST REMAIN WITHIN DIMENSIONS		THIS DRAWING CONTAINS INFORMATION THAT IS PROPRIETARY TO MOLEX INCORPORATED AND SHOULD NOT BE USED WITHOUT WRITTEN PERMISSION					



Компания «ЭлектроПласт» предлагает заключение долгосрочных отношений при поставках импортных электронных компонентов на взаимовыгодных условиях!

Наши преимущества:

- Оперативные поставки широкого спектра электронных компонентов отечественного и импортного производства напрямую от производителей и с крупнейших мировых складов;
- Поставка более 17-ти миллионов наименований электронных компонентов;
- Поставка сложных, дефицитных, либо снятых с производства позиций;
- Оперативные сроки поставки под заказ (от 5 рабочих дней);
- Экспресс доставка в любую точку России;
- Техническая поддержка проекта, помощь в подборе аналогов, поставка прототипов;
- Система менеджмента качества сертифицирована по Международному стандарту ISO 9001;
- Лицензия ФСБ на осуществление работ с использованием сведений, составляющих государственную тайну;
- Поставка специализированных компонентов (Xilinx, Altera, Analog Devices, Intersil, Interpoint, Microsemi, Aeroflex, Peregrine, Syfer, Eurofarad, Texas Instrument, Miteq, Cobham, E2V, MA-COM, Hittite, Mini-Circuits, General Dynamics и др.);

Помимо этого, одним из направлений компании «ЭлектроПласт» является направление «Источники питания». Мы предлагаем Вам помощь Конструкторского отдела:

- Подбор оптимального решения, техническое обоснование при выборе компонента;
- Подбор аналогов;
- Консультации по применению компонента;
- Поставка образцов и прототипов;
- Техническая поддержка проекта;
- Защита от снятия компонента с производства.



#### Как с нами связаться

**Телефон:** 8 (812) 309 58 32 (многоканальный)

**Факс:** 8 (812) 320-02-42

**Электронная почта:** [org@eplast1.ru](mailto:org@eplast1.ru)

**Адрес:** 198099, г. Санкт-Петербург, ул. Калинина, дом 2, корпус 4, литера А.