

10034542-XXXXXX

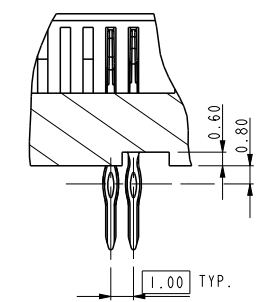

rev	ecn no	dr	date
N	DG07-0306	CS	2007-07-27
P	DG07-0416	CS	2007-10-22
R	DG-15684-1	ERIC	2013-11-08

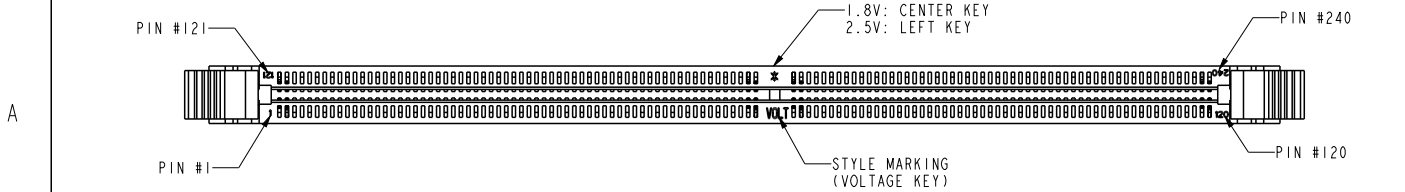

DETAIL A
SCALE 3.000

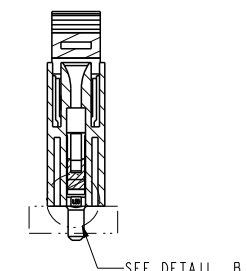
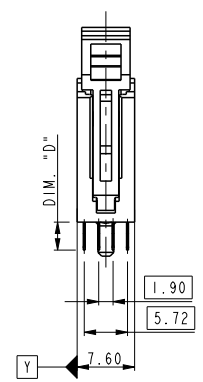
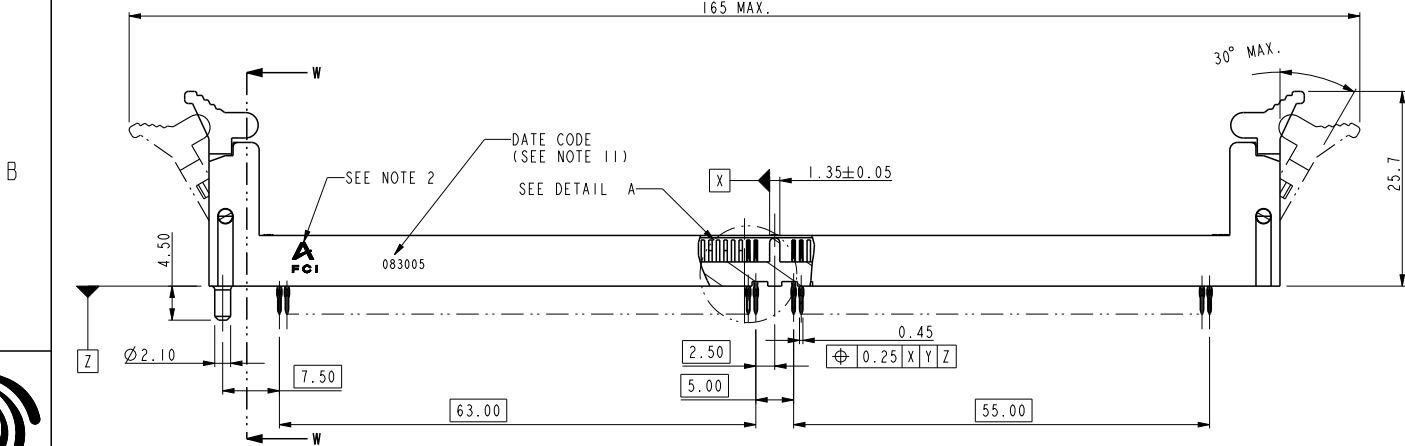

SECTION W-W
SCALE 1.000

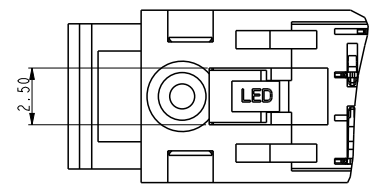
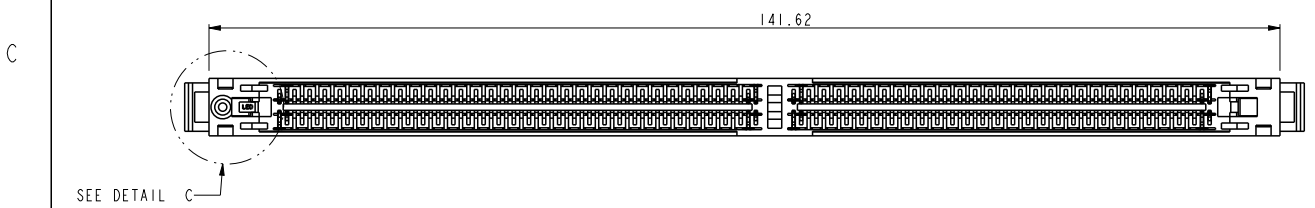

DETAIL C
SCALE 3.000

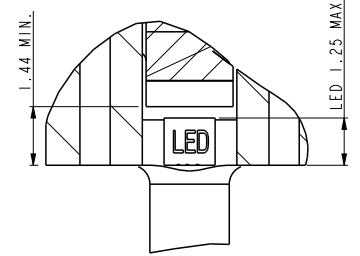

DETAIL B
SCALE 5.000

Copyright FCI.

spec ref	*	dr	Rick Bian	2010/07/03	projection	MM	size	A4	scale	0.500
tolerance std	ASME Y14.5	eng	Eric Jiang	2013/11/25			ecn no	ELX-DG-15684-1		
TOLERANCES UNLESS OTHERWISE SPECIFIED		chr	Tian-Xu Huang	2013/11/25				rel level	Released	
surface	✓	appr	Pei-Ming Zheng	2013/11/25	product family		dwg no		10034542	rev
ASME Y14.5	linear	0.X	±0.38		title		DDR 11 240P PRESS-FIT		sheet 1 of 5	R
		0.XX	±0.25		cat. no.		Product - Customer Drw			
		0.XXX	±0.13		* 10034542		STATUS:Released			
	angular	0°	±2°	www.fci.com		Printed: Nov 26, 2013				

ProE File - REV C - 2009-06-09

10034542-XXXXXCXX

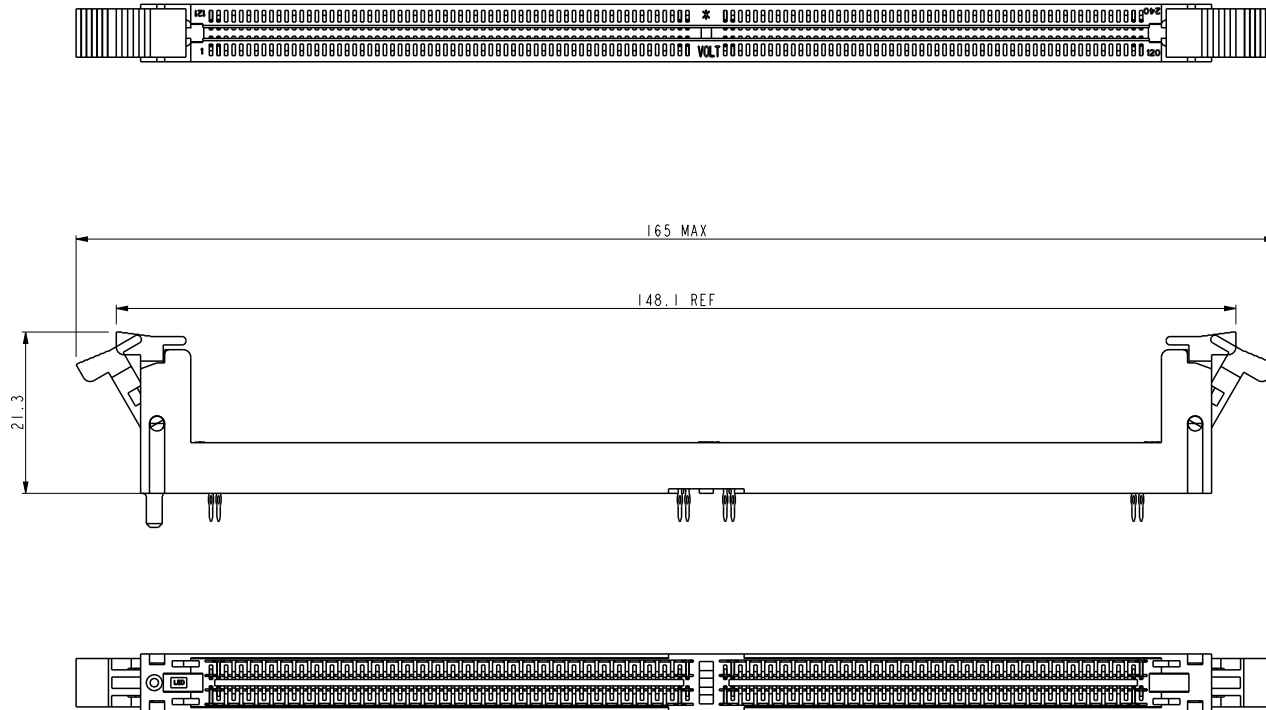

ALL DIMENSIONS ARE SAME TO PAGE 1 EXCEPT MARKED IN THE ABOVE

spec ref		*		dr	Rick Bian	2010/07/03	projection 	MM 	size	A4	scale	0.500
tolerance std		TOLERANCES UNLESS OTHERWISE SPECIFIED		eng	Eric Jiang	2013/11/25			ecn no	ELX-DG-15684-1		
ASME Y14.5				chr	Tian-Xu Huang	2013/11/25				rel level		Released
surface		linear	0.X	±0.38	FCI	title	DDR II 240P PRESS-FIT	dwg no	10034542		rev	R
ASME Y14.5			0.XX	±0.25								
		angular	0°	±2°	www.fci.com	cat. no.	*	Product - Customer Drw		sheet 2 of 5		



Copyright FCI.

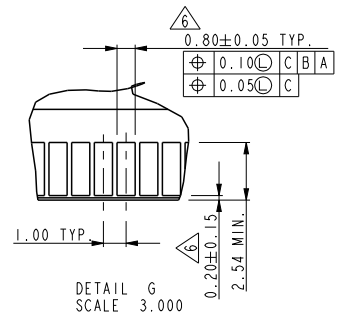
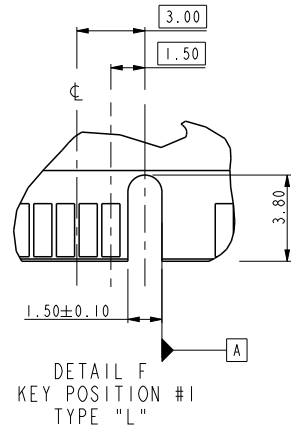
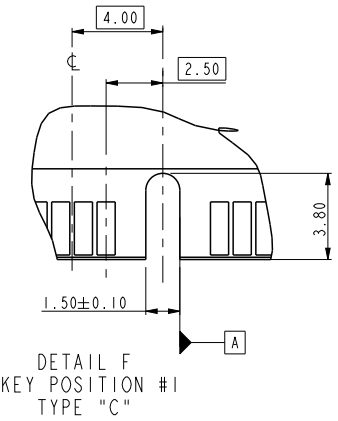
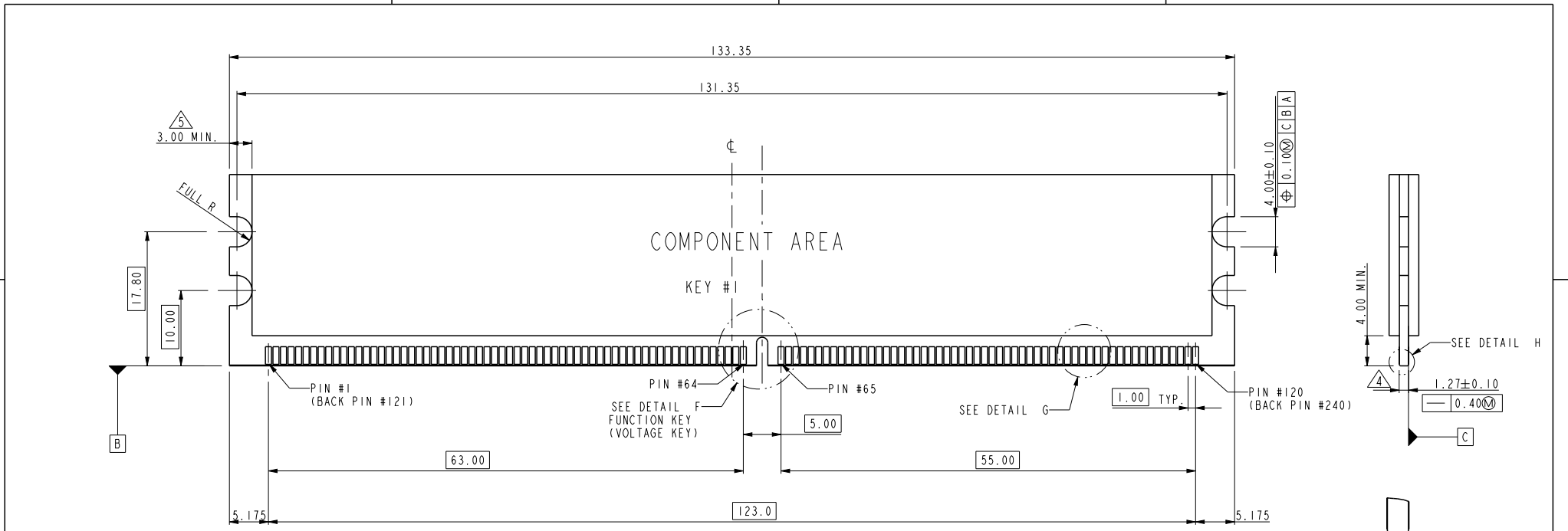

NOTE:
 1. MATERIAL : FR-4.
 2. FINISH: SOLDER MASK.
 3. BURR: 0.08 MAX.

SUB KEY POS #1	DESCRIPTION
TYPE "L"	2.5 VOLTAGE
TYPE "C"	1.8 VOLTAGE

spec ref	*	dr	Rick Bian	2010/07/03	projection	MM	size	A4	scale	0.500												
tolerance std	ASME Y14.5	eng	Eric Jiang	2013/11/25			ecn no	ELX-DG-15684-1														
TOLERANCES UNLESS OTHERWISE SPECIFIED		chr	Tian-Xu Huang	2013/11/25				rel level	Released													
surface	<table border="1"> <tr> <td>linear</td> <td>0.X</td> <td>±0.38</td> </tr> <tr> <td></td> <td>0.XX</td> <td>±0.25</td> </tr> <tr> <td></td> <td>0.XXX</td> <td>±0.13</td> </tr> <tr> <td>angular</td> <td>0°</td> <td>±2°</td> </tr> </table>	linear	0.X	±0.38		0.XX	±0.25		0.XXX	±0.13	angular	0°	±2°	appr	Pei-Ming Zheng	2013/11/25	product family	dwg no	10034542		rev	R
linear	0.X	±0.38																				
	0.XX	±0.25																				
	0.XXX	±0.13																				
angular	0°	±2°																				
ASME Y14.5		www.fci.com	cat. no.	*	Product - Customer Drw	sheet 3 of 5																

PrdE File - REV C - 2009-06-09



Copyright FCI.



RECOMMEND CIRCUIT BOARD HOLE LAYOUT

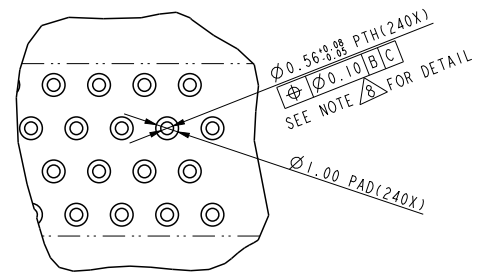

spec ref	*	dr	Rick Bian	2010/07/03	projection	MM	size	A4	scale	0.500	
tolerance std	TOLERANCES UNLESS OTHERWISE SPECIFIED	eng	Eric Jiang	2013/11/25				ecn no	ELX-DG-15684-1		
ASME Y14.5		chr	Tian-Xu Huang	2013/11/25				product family	rel level	Released	
surface		✓	appr	Pei-Ming Zheng		2013/11/25		title	DDR II 240P PRESS-FIT	dwg no	10034542
ASME Y14.5	linear	0.X	±0.38	www.fci.com	cat. no.	*	Product - Customer Drw		sheet 4 of 5		
		0.XX	±0.25								
		0.XXX	±0.13								
	angular	0°	±2°								

PrdE File - REV C - 2009-06-09

10034542-□□□□□□□



STYLE: MECHAMICAL KEYING

1 : 1.8 VOLT. W/CENTER KEY #1
2 : 2.5 VOLT. W/LEFT KEY #1

REVISE

0

TAIL LENGTH

CODE	DIM. "D"
0	3.30
1	3.70
2	4.20

FOR ROHS OPTION:
BLANK: TIN LEAD
LF: LEAD FREE

FOR LATCH TYPE OPTION:
BLANK: TALL LATCH
C: SHORT LATCH

CODE	CONTACT	TAIL AREA	UNDERPLATE	CODE	CONTACT	TAIL AREA	UNDERPLATE
2	15u"(0.38um) MIN. GOLD	35u"-100u" Tin PLATING	50u"(1.27um) MIN. NICKEL OVERALL	2B	15u"(0.38um) MIN. GOLD	35u"-100u" Tin/Lead PLATING	50u"(1.27um) MIN. NICKEL OVERALL
3	30u"(0.76um) MIN. GOLD			3B	30u"(0.76um) MIN. GOLD		
4	3u"(0.076um) MIN. GOLD			4B	3u"(0.076um) MIN. GOLD		
6	15u"(0.38um) MIN. GOLD (LUBRICATED)			6B	15u"(0.38um) MIN. GOLD (LUBRICATED)		
7	30u"(0.76um) MIN. GOLD (LUBRICATED)	35u"-100u" Tin PLATING	50u"(1.27um) MIN. NICKEL OVERALL	7B	30u"(0.76um) MIN. GOLD (LUBRICATED)	35u"-100u" Tin/Lead PLATING	50u"(1.27um) MIN. NICKEL OVERALL
8	3u"(0.076um) MIN. GOLD (LUBRICATED)			8B	3u"(0.076um) MIN. GOLD (LUBRICATED)		

NOTE:

- MATERIAL:
HOUSING: HIGH PERFORMANCE RESINS, GLASS FILLED UL94V-0 RATED, COLOR: BLACK.
EJECTOR: HIGH PERFORMANCE RESINS, GLASS FILLED UL94V-0 RATED, COLOR: NATURAL.
TERMINAL: COPPER ALLOY.
- FCI LOGO TO BE APPROXIMATELY LOCATED AS SHOWN ON PRINT.
- PRODUCT SPECIFICATION: GS-12-273
- CARD THICKNESS APPLIES ACROSS TABS AND INCLUDES PLATING AND / OR METALIZATION.
- 3.00mm MINIMUM APPLIES TO BOTH 4.00mm WIDE NOTCH LENGTH AND COMPONENT KEEPOUT AREA.
- LEADING EDGE OF CONTACT PADS SPECIFIED BY THE KEEP OUT ZONE SHALL BE FREE OF BURRS AND EXTERNAL TIE BARS.
FOR OPTIMUM PERFORMANCE, THE TIE BAR IS TO BE ON AN INTERNAL LAYER SO THAT THE REMNANT CANNOT CAUSE CONTACT DAMAGE.
- PACKAGING SPECIFICATION: GS-14-528.
- ALL PTH SHOULD BE 0.66mm DIA DRILLED AND 0.025mm MIN. ELECTRO-DEPOSITED COPPER THK ON THROUGH HOLE WALL.
- THIS PRODUCT MEETS EUROPEAN UNION DIRECTIVES AND OTHER COUNTRY REGULATIONS AS DESCRIBED IN GS-22-008.
- THE HOUSING WILL WITHSTAND EXPOSURE TO 260° PEAK TEMPERATURE FOR 20 SECONDS IN A IR REFLOW OVEN.

DATE CODE: X X X X X X

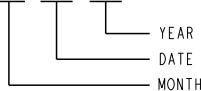

COLOR OF HOUSING AN EJECTOR

- 0 : BLACK HOUSING + IVORY EJECTOR
- 1 : BLACK HOUSING + AMBER EJECTOR
- 2 : BLACK HOUSING + BLACK EJECTOR
- 3 : BLUE HOUSING + IVORY EJECTOR
- 4 : BLUE HOUSING + AMBER EJECTOR

dr	Rick Bian	2010/07/03	projection 	MM 	size	A4	scale	0.500
eng	Eric Jiang	2013/11/25			ecn no	ELX-DG-15684-1		
chr	Tian-Xu Huang	2013/11/25			rel level	Released		
appr	Pei-Ming Zheng	2013/11/25	product family				rev	R
		title	DDR II 240P PRESS-FIT		dwg no	10034542		
www.fci.com		cat. no.	*	Product - Customer Drw			sheet 5 of 5	

12. A SYMBOL WILL BE NEXT TO ANY DIMENSION, VIEW, OR NOTE WHICH HAS BEEN MODIFIED WITH THE CURRENT DRAWING REVISION



Copyright FCI.



Компания «ЭлектроПласт» предлагает заключение долгосрочных отношений при поставках импортных электронных компонентов на взаимовыгодных условиях!

Наши преимущества:

- Оперативные поставки широкого спектра электронных компонентов отечественного и импортного производства напрямую от производителей и с крупнейших мировых складов;
- Поставка более 17-ти миллионов наименований электронных компонентов;
- Поставка сложных, дефицитных, либо снятых с производства позиций;
- Оперативные сроки поставки под заказ (от 5 рабочих дней);
- Экспресс доставка в любую точку России;
- Техническая поддержка проекта, помощь в подборе аналогов, поставка прототипов;
- Система менеджмента качества сертифицирована по Международному стандарту ISO 9001;
- Лицензия ФСБ на осуществление работ с использованием сведений, составляющих государственную тайну;
- Поставка специализированных компонентов (Xilinx, Altera, Analog Devices, Intersil, Interpoint, Microsemi, Aeroflex, Peregrine, Syfer, Eurofarad, Texas Instrument, Miteq, Cobham, E2V, MA-COM, Hittite, Mini-Circuits, General Dynamics и др.);

Помимо этого, одним из направлений компании «ЭлектроПласт» является направление «Источники питания». Мы предлагаем Вам помощь Конструкторского отдела:

- Подбор оптимального решения, техническое обоснование при выборе компонента;
- Подбор аналогов;
- Консультации по применению компонента;
- Поставка образцов и прототипов;
- Техническая поддержка проекта;
- Защита от снятия компонента с производства.



Как с нами связаться

Телефон: 8 (812) 309 58 32 (многоканальный)

Факс: 8 (812) 320-02-42

Электронная почта: org@eplast1.ru

Адрес: 198099, г. Санкт-Петербург, ул. Калинина, дом 2, корпус 4, литера А.