

THIS DRAWING IS UNPUBLISHED. RELEASED FOR PUBLICATION
 © COPYRIGHT copyright.d8Te- ALL RIGHTS RESERVED.

REVISIONS				
P	LTR	DESCRIPTION	DATE	APVD
	A	RELEASED FOR PRODUCTION	23OCT2017	RK PO

NOTES:

- ① LID NOT ASSEMBLED WITH LOWER PART. ENCLOSED LOOSELY
- ② FLAP NOT ASSEMBLED WITH LOWER PART. ENCLOSED LOOSELY
- ③ PART NUMBER.
- ④ PRODUCTION DATE (YYMMDD)
- ⑤ MANUFACTURING LOCATION CODE.
- ⑥ FOIL CLIP INSTALLED ON BOX CONTACT RAILS
- ⑦ MODEL CODE ACCORDING TE-SPEC. 404-74000-1
- ⑧ CONSECUTIVE SERIAL NUMBER
- ⑨ TEST EQUIPMENT NUMBER
- ⑩ DIODES WELDED ON CONTACT RAIL.
- 11. MUST COMPLY WITH DIRECTIVE 2002/95/EC (ROHS).
- 12. THIS PRODUCT HAS NOT COMPLETED VALIDATION TESTING.

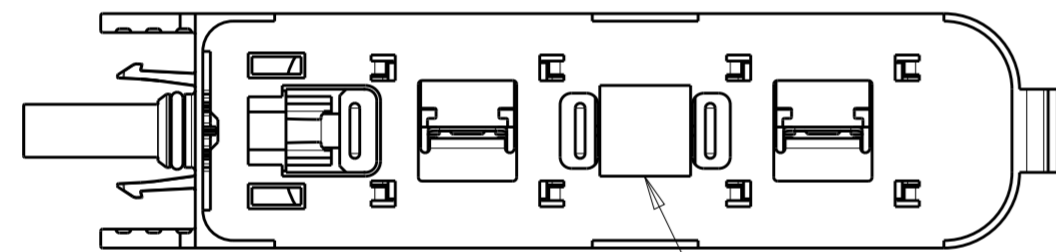
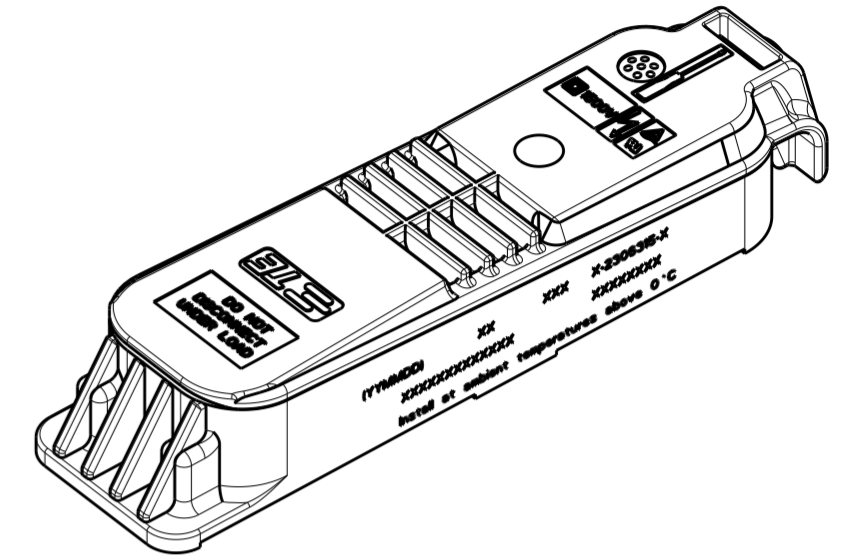
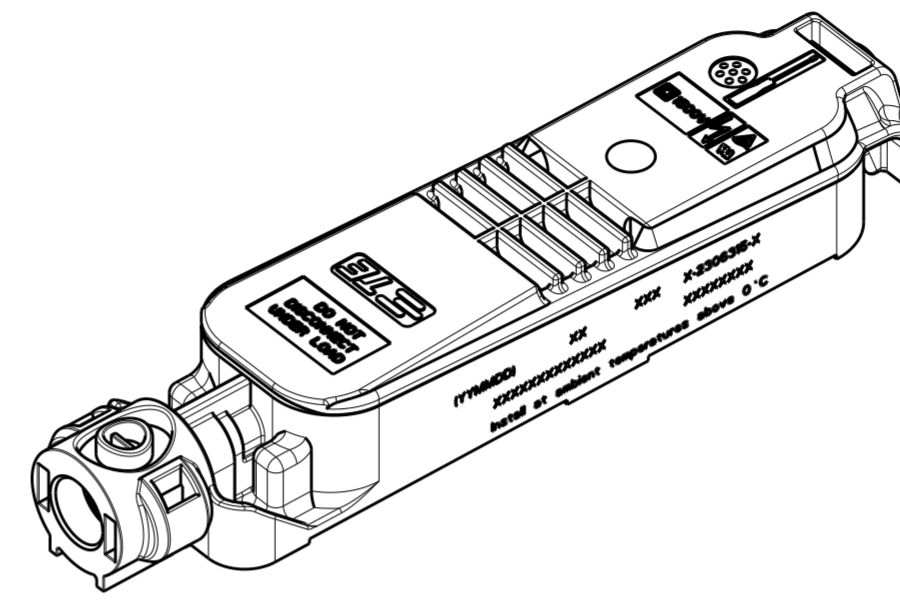
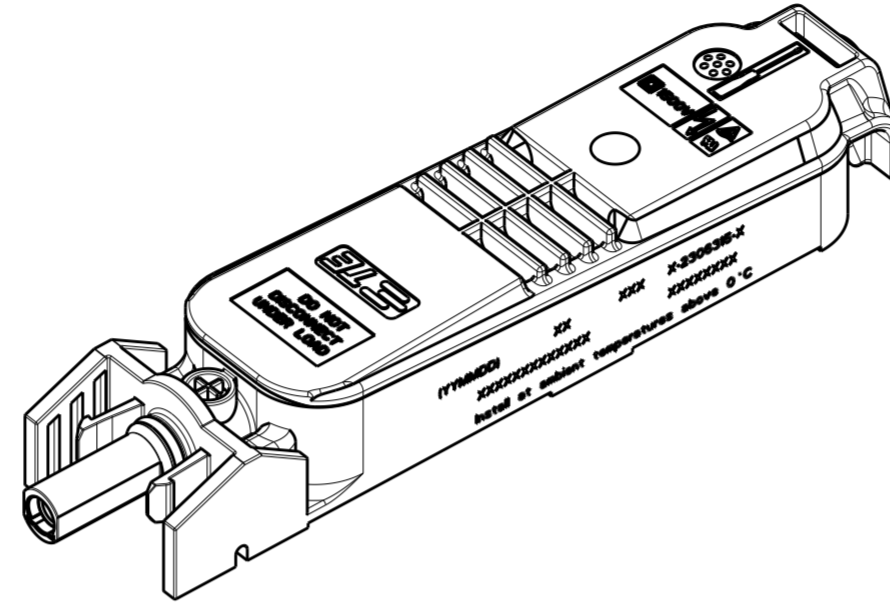

MOUNTING TAPE

BOTTOM VIEW OF TYPICAL ASSEMBLY WHEN MOUNTING TAPE IS APPLIED

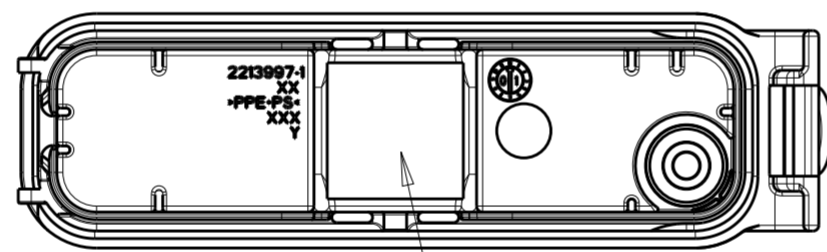

THERMAL INTERFACE MATERIAL

BOTTOM VIEW OF LID SUBASSEMBLY WHEN THERMAL INTERFACE MATERIAL IS APPLIED

PVEDGE2GGA1V_2	36.0	EAST/WEST	YES	YES	7-2306315-5
PVEDGE2DGA1V_2	55.2	EAST/WEST	YES	YES	7-2306315-2
PVEDGE2FGA1V_2	58.7	EAST/WEST	YES	YES	7-2306315-1
PVEDGE2GGA1V_2	36.0	EAST/WEST	NO	YES	6-2306315-5
PVEDGE2DGA1V_2	55.2	EAST/WEST	NO	YES	6-2306315-2
PVEDGE2FGA1V_2	58.7	EAST/WEST	NO	YES	6-2306315-1
PVEDGE2DGA1T_2	36.0	EAST/WEST	YES	NO	5-2306315-5
PVEDGE2DGA1T_2	55.2	EAST/WEST	YES	NO	5-2306315-2
PVEDGE2FGA1T_2	58.7	EAST/WEST	YES	NO	5-2306315-1
PVEDGE2GGA1T_2	36.0	EAST/WEST	NO	NO	4-2306315-5
PVEDGE2DGA1T_2	55.2	EAST/WEST	NO	NO	4-2306315-2
PVEDGE2FGA1T_2	58.7	EAST/WEST	NO	NO	4-2306315-1
PVEDGE2GGA1V_2	36.0	NORTH/SOUTH	YES	YES	3-2306315-5
PVEDGE2DGA1V_2	55.2	NORTH/SOUTH	YES	YES	3-2306315-2
PVEDGE2FGA1V_2	58.7	NORTH/SOUTH	YES	YES	3-2306315-1
PVEDGE2GGA1V_2	36.0	NORTH/SOUTH	NO	YES	2-2306315-5
PVEDGE2DGA1V_2	55.2	NORTH/SOUTH	NO	YES	2-2306315-2
PVEDGE2FGA1V_2	58.7	NORTH/SOUTH	NO	YES	2-2306315-1
PVEDGE2GGA1T_2	36.0	NORTH/SOUTH	YES	NO	1-2306315-5
PVEDGE2DGA1T_2	55.2	NORTH/SOUTH	YES	NO	1-2306315-2
PVEDGE2FGA1T_2	58.7	NORTH/SOUTH	YES	NO	1-2306315-1
PVEDGE2GGA1T_2	36.0	NORTH/SOUTH	NO	NO	2306315-5
PVEDGE2DGA1T_2	55.2	NORTH/SOUTH	NO	NO	2306315-2
PVEDGE2FGA1T_2	58.7	NORTH/SOUTH	NO	NO	2306315-1
MODEL CODE ⑦	DIM X	PV PANEL FOIL DIRECTION	MOUNTING TAPE	THERMAL INTERFACE MATERIAL	PART NO.

TIN OVER NICKEL	COPPER ALLOY	INTERFACE CONTACT-SOCKET	11
TIN OVER NICKEL	COPPER ALLOY	INTERFACE CONTACT-PIN	10
-	-	THERMAL INTERFACE MATERIAL	9
-	-	BYPASS DIODE: TYPE SL2020A	8
GRAY	PPE+PS	MEMBRANE RETAINER	7
-	-	MEMBRANE VENT	6
PLAIN	STAINLESS STEEL	FOIL CLIP	5 ⑥
TIN	COPPER ALLOY	CONTACT RAIL	4
BLACK	PPE+PS	BOX, LOWER HOUSING	3
RED	SILICONE	O-RING SEAL	2
BLACK	PPE+PS	BOX, LID	1 ①
COLOR/FINISH	MATERIAL	DESCRIPTION	ITEM NO.

THIS DRAWING IS A CONTROLLED DOCUMENT.

DIMENSIONS: mm	TOLERANCES UNLESS OTHERWISE SPECIFIED:	DWN RAVLS 12AUG2016	TE Connectivity
	0 PLC ±0.50	CHK GINGRICH CHUCK 12AUG2016	
	1 PLC ±0.25	APVD GINGRICH CHUCK 12AUG2016	
	2 PLC ±0.13	PRODUCT SPEC 108-32122	
MATERIAL	3 PLC ±	APPLICATION SPEC 114-32157	NAME PV EDGE ASSEMBLY, WITHOUT FLAP, S CLIP
①	4 PLC ANGLES ±	WEIGHT -	SIZE A2
	FINISH -	CUSTOMER DRAWING	CAGE CODE -
		SCALE 1:1	DRAWING NO. C-2306315
		SHEET 1 OF 4	RESTRICTED TO -
		REV A	

THIS DRAWING IS UNPUBLISHED. RELEASED FOR PUBLICATION
 © COPYRIGHT copyright.d8Te- ALL RIGHTS RESERVED.

REVISIONS				
P	LTR	DESCRIPTION	DATE	APVD
-		SEE SHEET 1	-	-

LID NOT SHOWN FOR REFERENCE ONLY

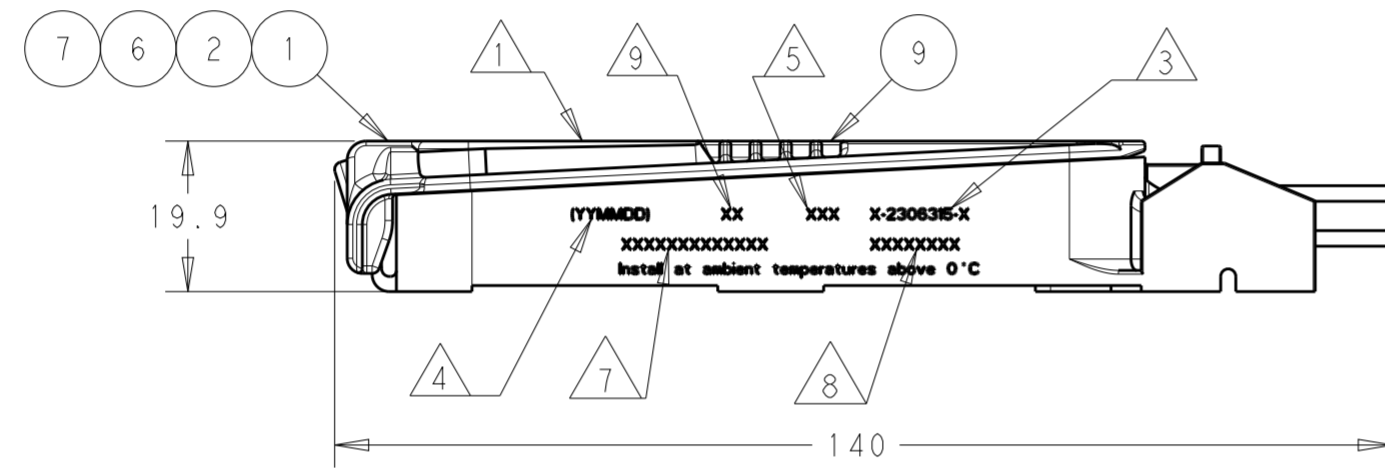
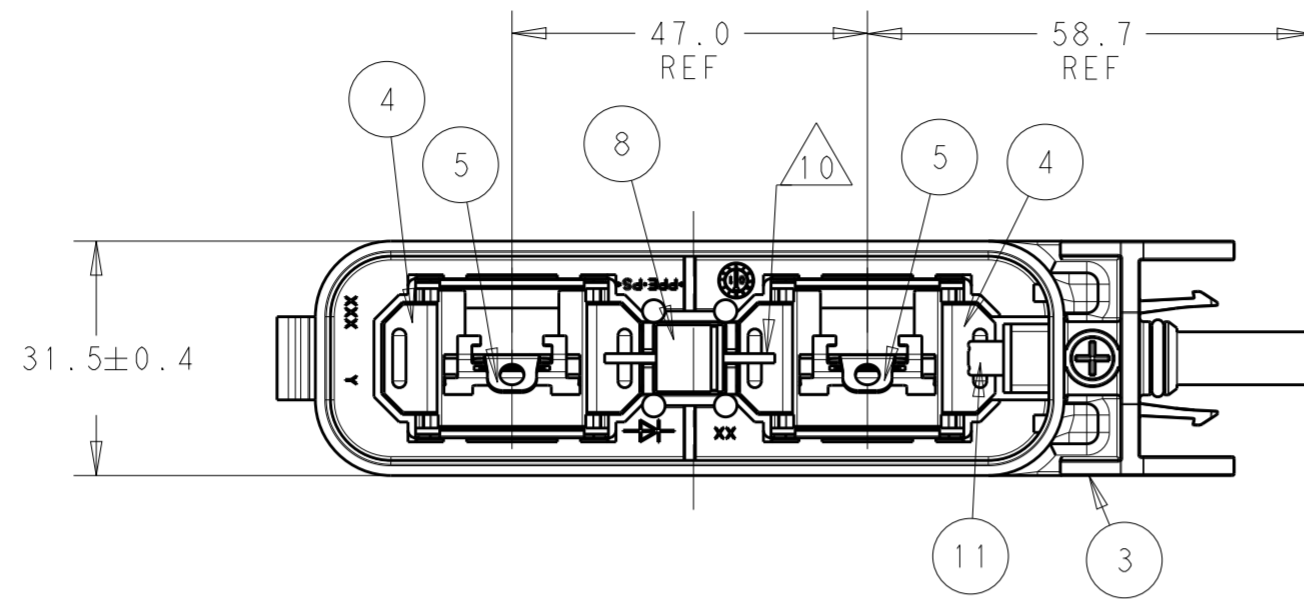

NORTH-SOUTH VERSIONS
 2306315-1
 1-2306315-1
 2-2306315-1
 3-2306315-1
 SHOWN

LID NOT SHOWN FOR REFERENCE ONLY

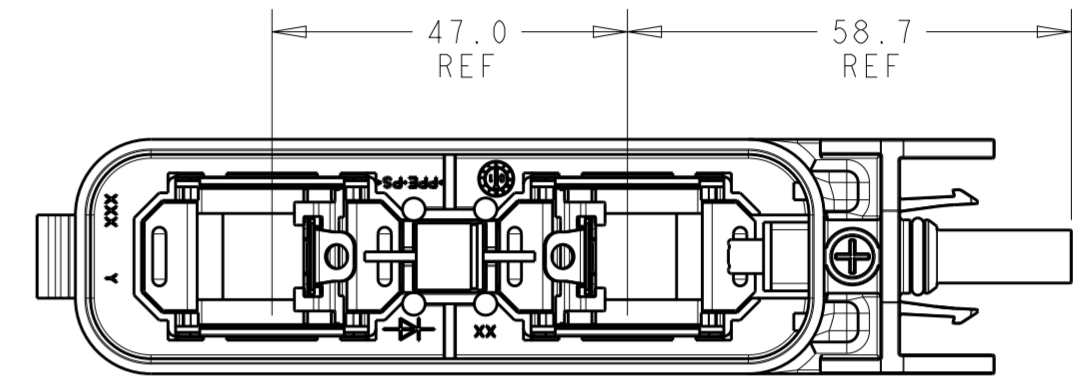

EAST-WEST VERSIONS
 4-2306315-1
 5-2306315-1
 6-2306315-1
 7-2306315-1
 SAME AS N-S VERSIONS
 EXCEPT AS SHOWN

LID NOT SHOWN FOR REFERENCE ONLY

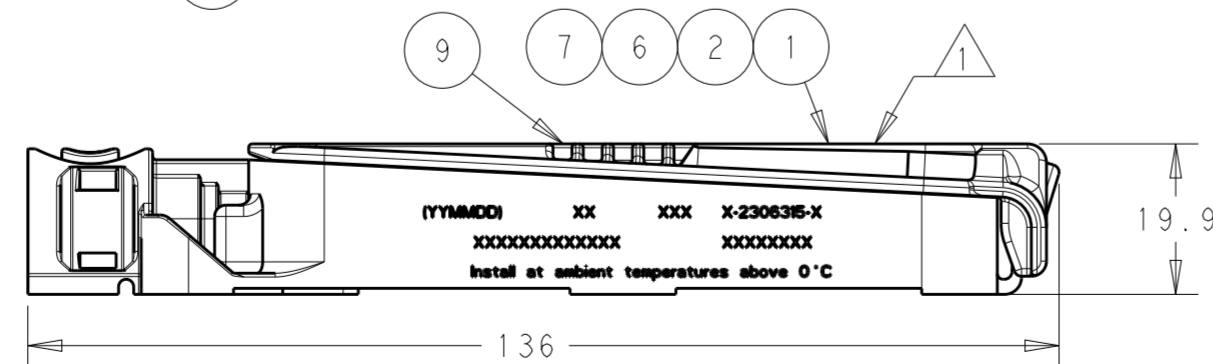
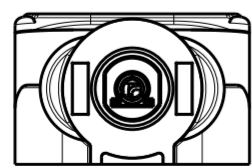
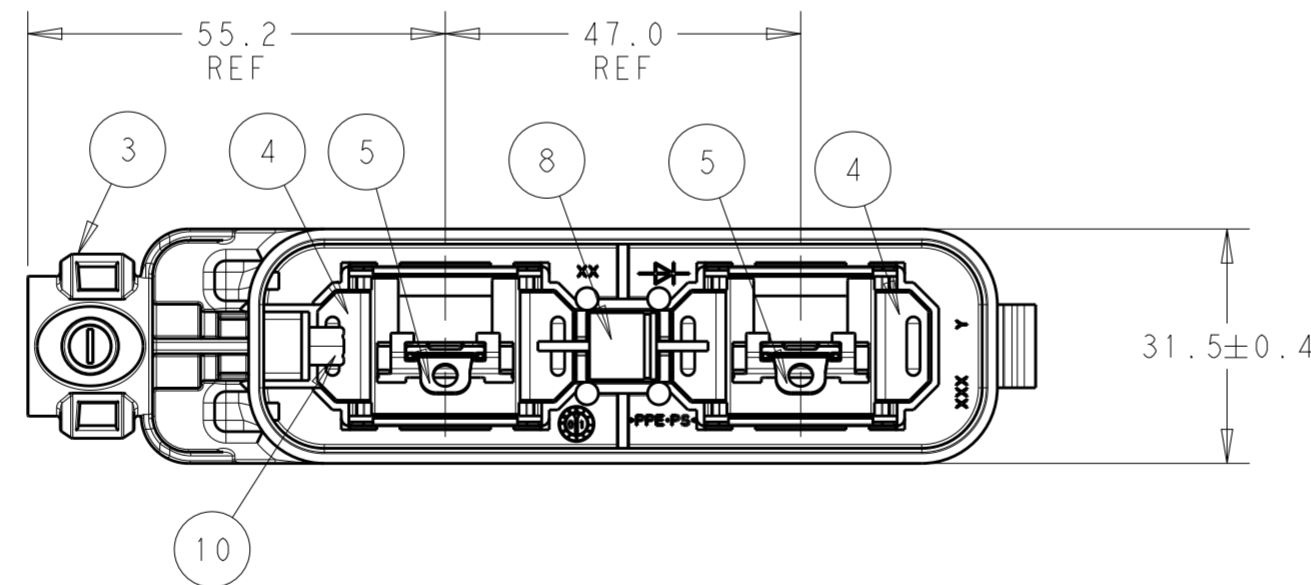

NORTH-SOUTH VERSIONS
 2306315-2
 1-2306315-2
 2-2306315-2
 3-2306315-2
 SHOWN

LID NOT SHOWN FOR REFERENCE ONLY

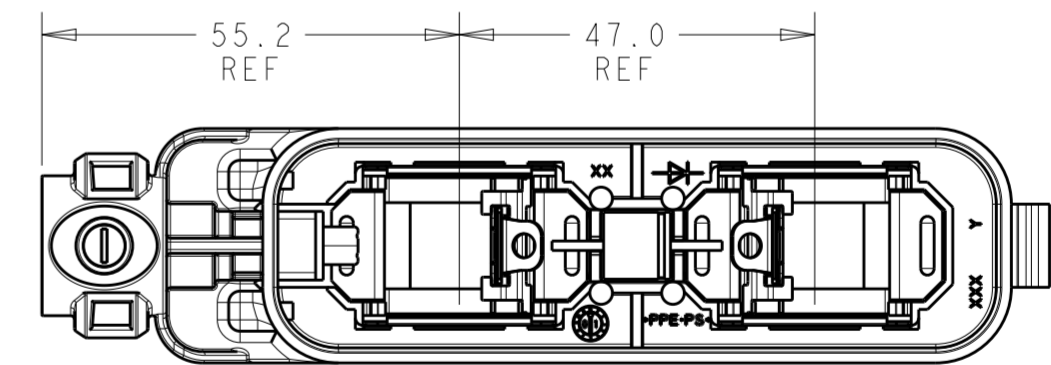

EAST-WEST VERSIONS
 4-2306315-2
 5-2306315-2
 6-2306315-2
 7-2306315-2
 SAME AS N-S VERSIONS
 EXCEPT AS SHOWN

THIS DRAWING IS A CONTROLLED DOCUMENT.		DWN RAVLS 12AUG2016	 TE Connectivity	
DIMENSIONS: mm		CHK GINGRICH CHUCK 12AUG2016		
TOLERANCES UNLESS OTHERWISE SPECIFIED:		APVD GINGRICH CHUCK 12AUG2016	NAME PV EDGE ASSEMBLY, WITHOUT FLAP, S CLIP	
0 PLC ±0.50		PRODUCT SPEC 108-32122	RESTRICTED TO	
1 PLC ±0.25		APPLICATION SPEC 114-32157	SIZE A2	CAGE CODE -
2 PLC ±0.13		WEIGHT -	DRAWING NO G-2306315	SCALE 5:1
3 PLC ±		CUSTOMER DRAWING	SHEET 2 OF 4	REV A
4 PLC ±				
ANGLES ±				
FINISH -				

THIS DRAWING IS UNPUBLISHED. RELEASED FOR PUBLICATION
 © COPYRIGHT copyright.d8te- ALL RIGHTS RESERVED.

REVISIONS				
P	LTR	DESCRIPTION	DATE	APVD
-		SEE SHEET 1	-	-

LID NOT SHOWN FOR REFERENCE ONLY

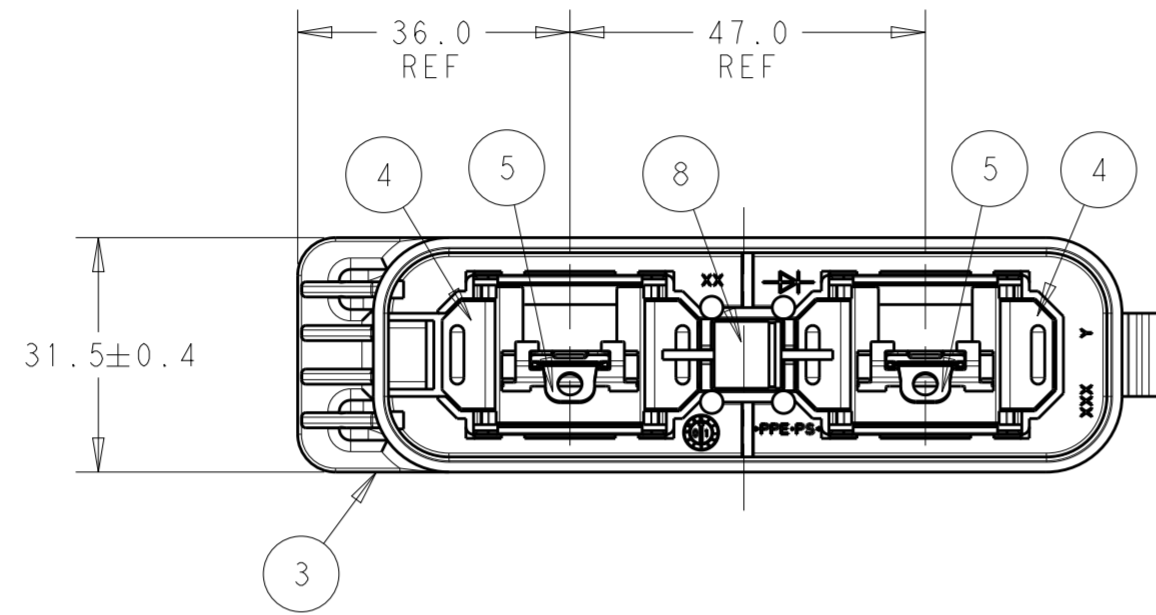

LID NOT SHOWN FOR REFERENCE ONLY

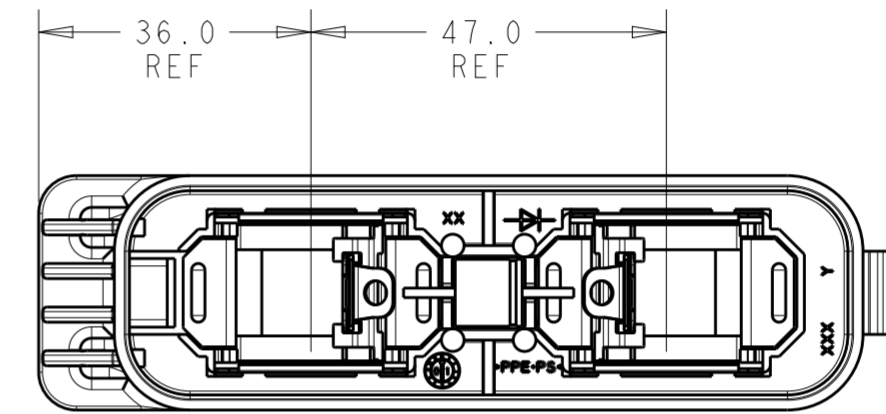

EAST-WEST VERSIONS
 4-2306315-5
 5-2306315-5
 6-2306315-5
 7-2306315-5
 SAME AS N-S VERSIONS
 EXCEPT AS SHOWN

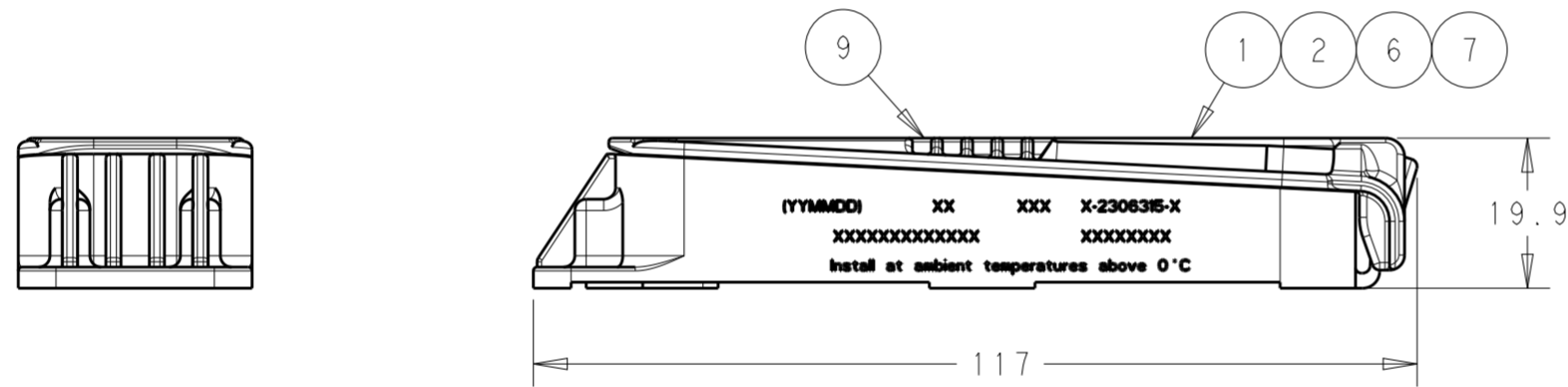

NORTH-SOUTH VERSIONS
 2306315-5
 1-2306315-5
 2-2306315-5
 3-2306315-5
 SHOWN

THIS DRAWING IS A CONTROLLED DOCUMENT.		DWN RAVI.S 12AUG2016	TE Connectivity	
DIMENSIONS: mm		CHK GINGRICH 12AUG2016		
TOLERANCES UNLESS OTHERWISE SPECIFIED:		APVD GINGRICH 12AUG2016	NAME PV EDGE ASSEMBLY, WITHOUT FLAP, S CLIP	
0 PLC ±0.50		PRODUCT SPEC 108-32122	SIZE A2	
1 PLC ±0.25		APPLICATION SPEC 114-32157	CAGE CODE -	DRAWING NO C-2306315
2 PLC ±0.13		WEIGHT -	RESTRICTED TO -	
3 PLC ±		CUSTOMER DRAWING	SCALE 5:1	SHEET 3 OF 4
4 PLC ±			REV A	
ANGLES ±				
FINISH -				

THIS DRAWING IS UNPUBLISHED. RELEASED FOR PUBLICATION
 © COPYRIGHT copyright.d8Te- ALL RIGHTS RESERVED.

REVISIONS				
P	LTR	DESCRIPTION	DATE	APVD
-	-	SEE SHEET 1	-	-

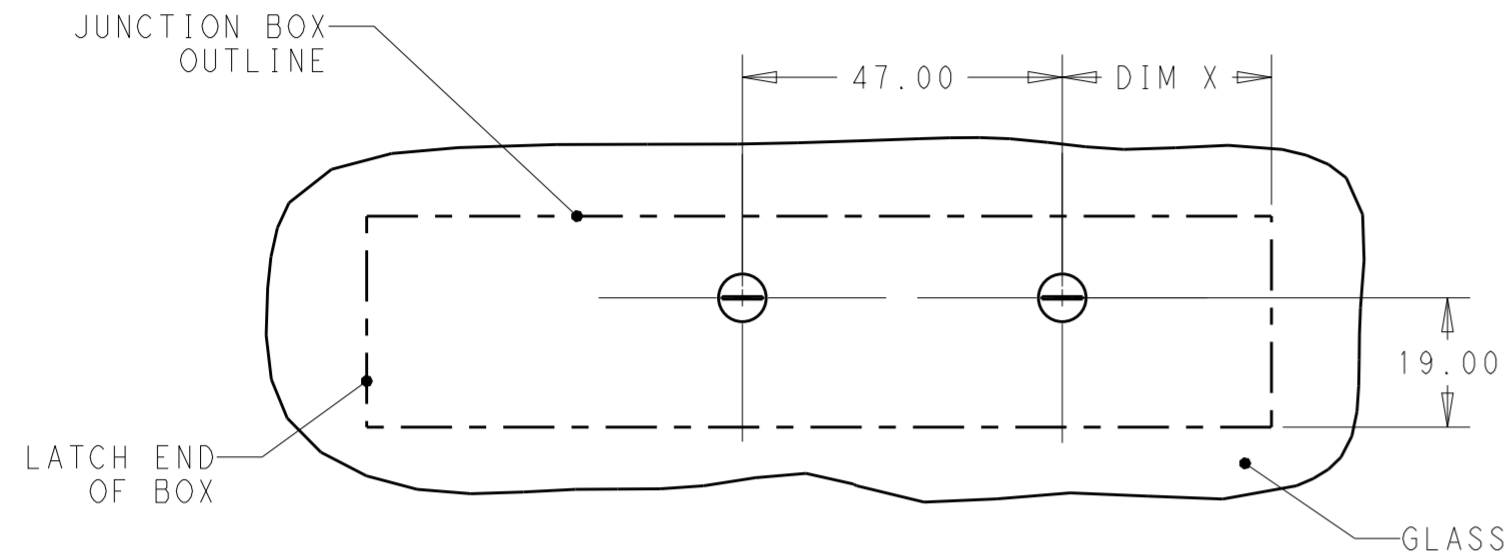

RECOMMENDED NON-EDGE MOUNT
 (NORTH-SOUTH PV PANEL FOIL ORIENTATION)

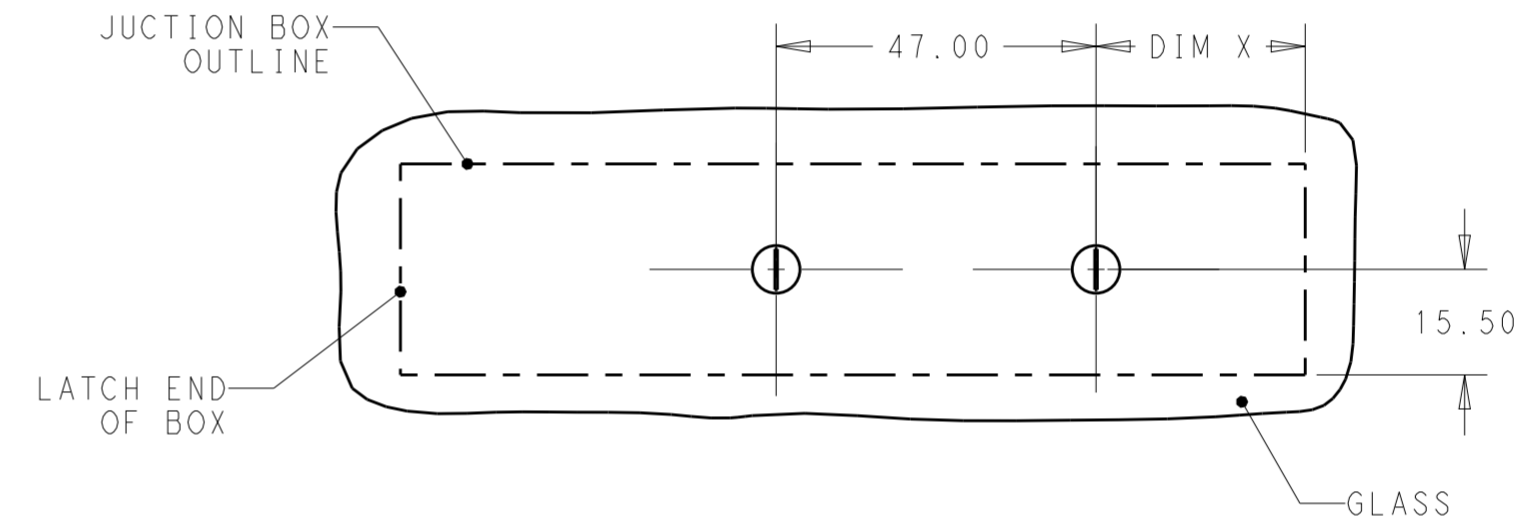
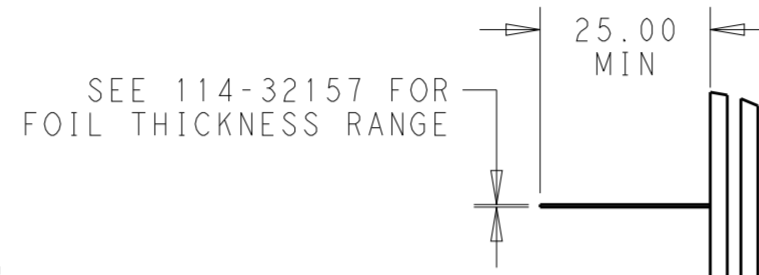

RECOMMENDED NON-EDGE MOUNT
 (EAST-WEST PV PANEL FOIL ORIENTATION)

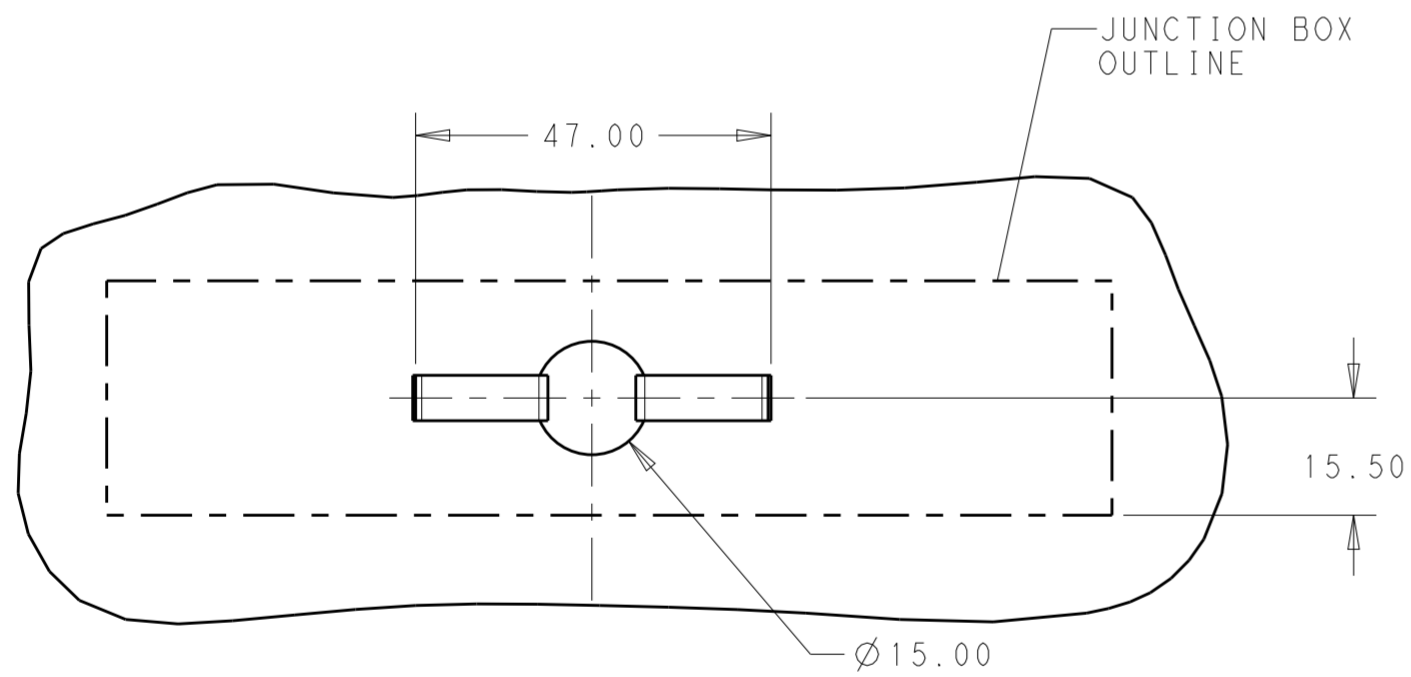
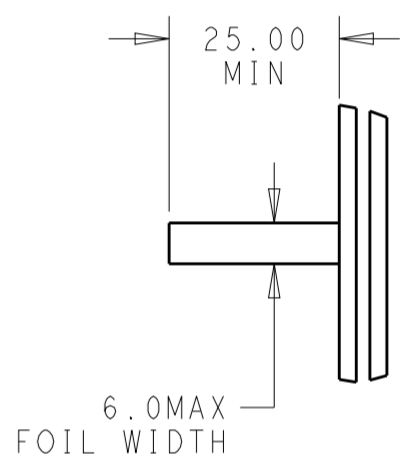

RECOMMENDED NON-EDGE MOUNT
 (SINGLE HOLE ORIENTATION)

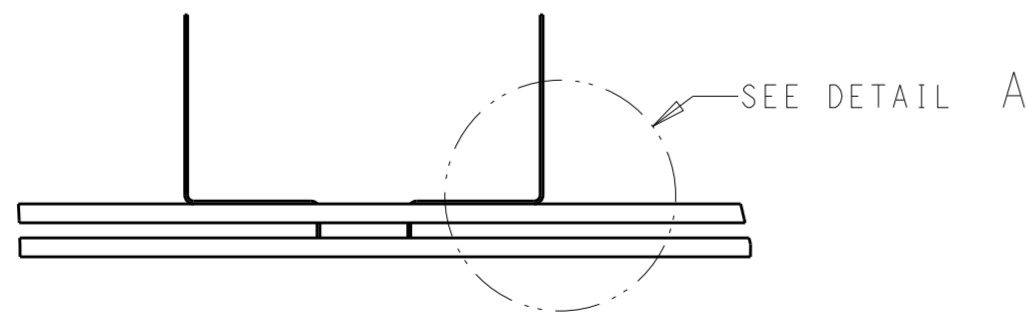
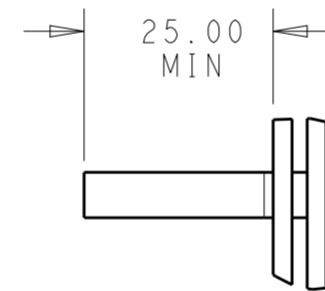

0.8 MAX TO BOTTOM SIDE OF FOIL FROM BOTTOM SIDE OF GLASS
 SEE 114-32157 FOR FOIL THICKNESS RANGE

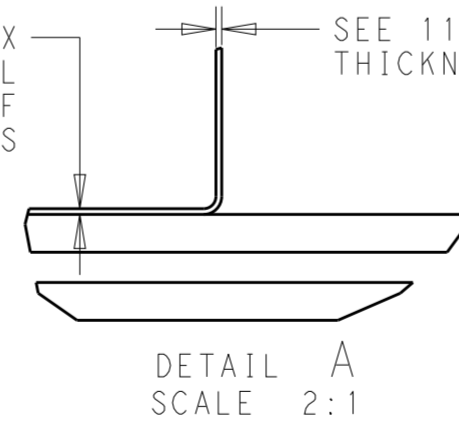

DETAIL A
 SCALE 2:1

THIS DRAWING IS A CONTROLLED DOCUMENT.		DWN RAVLS 12AUG2016	TE Connectivity	
DIMENSIONS: mm		CHK GINGRICH CHUCK 12AUG2016		
TOLERANCES UNLESS OTHERWISE SPECIFIED:		APVD GINGRICH CHUCK 12AUG2016	NAME PV EDGE ASSEMBLY, WITHOUT FLAP, S CLIP	
0 PLC ±0.50		PRODUCT SPEC 108-32122	RESTRICTED TO	
1 PLC ±0.25		APPLICATION SPEC 114-32157	SIZE A2	CAGE CODE -
2 PLC ±0.13		WEIGHT -	DRAWING NO C-2306315	
3 PLC ±		CUSTOMER DRAWING	SCALE 5:1	SHEET 4 OF 4
4 PLC ±			REV A	
ANGLES ±				
FINISH -				



Компания «ЭлектроПласт» предлагает заключение долгосрочных отношений при поставках импортных электронных компонентов на взаимовыгодных условиях!

Наши преимущества:

- Оперативные поставки широкого спектра электронных компонентов отечественного и импортного производства напрямую от производителей и с крупнейших мировых складов;
- Поставка более 17-ти миллионов наименований электронных компонентов;
- Поставка сложных, дефицитных, либо снятых с производства позиций;
- Оперативные сроки поставки под заказ (от 5 рабочих дней);
- Экспресс доставка в любую точку России;
- Техническая поддержка проекта, помощь в подборе аналогов, поставка прототипов;
- Система менеджмента качества сертифицирована по Международному стандарту ISO 9001;
- Лицензия ФСБ на осуществление работ с использованием сведений, составляющих государственную тайну;
- Поставка специализированных компонентов (Xilinx, Altera, Analog Devices, Intersil, Interpoint, Microsemi, Aeroflex, Peregrine, Syfer, Eurofarad, Texas Instrument, Miteq, Cobham, E2V, MA-COM, Hittite, Mini-Circuits, General Dynamics и др.);

Помимо этого, одним из направлений компании «ЭлектроПласт» является направление «Источники питания». Мы предлагаем Вам помощь Конструкторского отдела:

- Подбор оптимального решения, техническое обоснование при выборе компонента;
- Подбор аналогов;
- Консультации по применению компонента;
- Поставка образцов и прототипов;
- Техническая поддержка проекта;
- Защита от снятия компонента с производства.



Как с нами связаться

Телефон: 8 (812) 309 58 32 (многоканальный)

Факс: 8 (812) 320-02-42

Электронная почта: org@eplast1.ru

Адрес: 198099, г. Санкт-Петербург, ул. Калинина, дом 2, корпус 4, литера А.