

PSI² Power Supply in Inductor

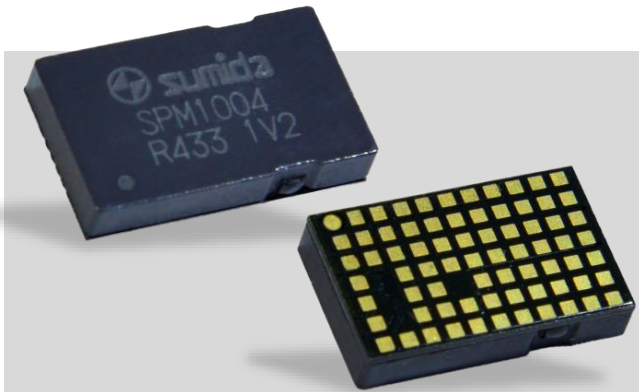

The next step in integration!

SUMIDA offers a new range of fully integrated power modules which feature outstanding performance with industry-leading power density. SUMIDA has leveraged its extensive experience in inductor technology to achieve the highest available efficiency as well as optimized packaging for thermal management.

In this product all components are integrated *within* the inductor which provides significant benefits:

- The maximum amount of magnetic material is used, rather than plastic fillers, allowing low loss and high efficiency
- The coil can use thicker wire for lower resistive losses and higher efficiency
- The magnetic material is thermally conductive, avoiding hot spots
- The inductor provides electromagnetic shielding for the switching components
- The integrated power module is fully tested and dramatically simplifies the end product design
- The small size and very low profile (3 mm) package reduces board space, allowing higher density designs

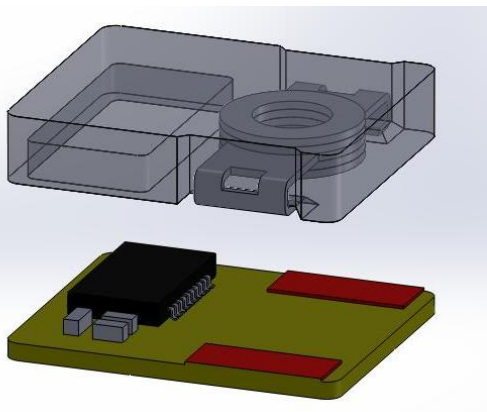

Efficiency

The high performance inductor minimizes losses at full load, and the circuit topology maintains excellent efficiency over the entire load range.

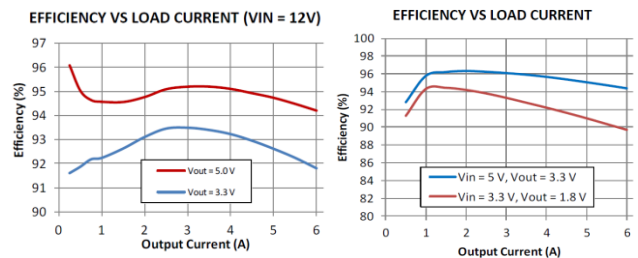

SPM1004

SPM1005

Thermal

The high conductivity of the magnetic material maintains a uniform temperature across the module and ensures that there are no "hot spots" (Figure 1). The measured surface temperature is reduced by 11.5°C compared to a power module with an internal inductor under identical conditions (Figure 2).



Figure 1 - SPM1005

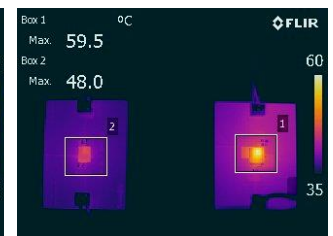
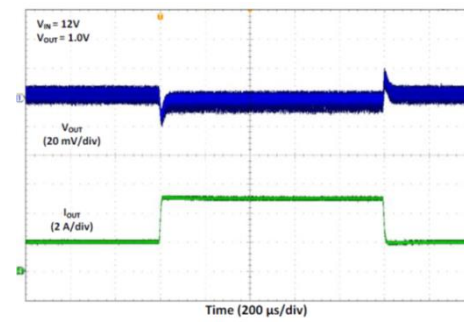

Figure 2 - Comparison

Transient response

The circuit topology has been chosen to provide an excellent response under transient load. The figure below shows less than 20mV transient under a 3A load step (SPM1004, Vin=12V and Vout=1V):



SPM1004
(Vin=12V and Vout=1V)

PSI² Power Supply in Inductor



Package size

The module is supplied in a Land Grid Array (LGA) package with a very low profile (3mm), and the footprint is only 9x15mm (SPM1004 and SPM1006) or 9x11mm (SPM1005). Very few external components are required because all major components are internal to the module, and because of the high efficiency no forced airflow is needed up to 85°C ambient. This makes it ideal for high density applications.

Design time

The module is fully tested during production and is guaranteed to meet specifications. This simplifies the end product design and PCB layout, and avoids surprises during system testing. In contrast, a power design based on separate components on the end product PCB is higher risk and typically takes longer to develop and debug.

Applications

- Broadband and communications equipment
- DSP and FPGA Point of Load applications
- High density distributed power systems
- Automated PCI / PCI express / PXI express
- Automated test and medical equipment

Specification summary

Parameter	Conditions	SPM1004	SPM1005	SPM1006
Input voltage		9 - 15V	2.95-6V	4 - 28V
Output current	-40 to +85°C	0-6A	0-6A	0-8A ¹
Output voltage		Fixed 0.8 - 5V	Adjustable 0.6 - 3.3V	Adjustable 0.6 - 5V
Efficiency	6A load	94.2% @5V	94.2% @3.3V	93% @5V
	3A load	95.2% @5V	96.1% @3.3V	94.1% @5V
Features		Power good output		
		Enable input		
		Soft start		
		Auxiliary output		
Protection		Overcurrent protection		
		Overvoltage protection		
		Undervoltage lockout		
		Thermal shutdown		
Package - LGA	Height	3 mm		
	Footprint	9 x 15 mm	9 x 11 mm	9 x 15 mm
	Pad size	0.63 mm		
Thermal	No airflow	-40 to +85°C		

¹ Maximum 6A continuous at 85°C; refer to datasheet

EMI performance

All internal power traces are very short, minimizing the loop area and reducing radiated EMI. The inductor material is conductive and acts as a shield over the internal components, further reducing EMI.

Evaluation boards



SPM1004 and SPM1006 Evaluation Boards



SPM1005 Evaluation Board

Ordering information (LGA package)

Output Voltage	SPM1004	SPM1005	SPM1006
Adjustable	(NA)	SPM1005-ZC	SPM1006-ZC
5.0V	SPM1004-5V0C	(NA)	SPM1006-5V0C
3.3V	SPM1004-3V3C	SPM1005-3V3C	SPM1006-3V3C
2.5V	SPM1004-2V5C	SPM1005-2V5C	SPM1006-2V5C
1.8V	SPM1004-1V8C	SPM1005-1V8C	SPM1006-1V8C
1.5V	SPM1004-1V5C	SPM1005-1V5C	SPM1006-1V5C
1.2V	SPM1004-1V2C	SPM1005-1V2C	SPM1006-1V2C
1.0V	SPM1004-1V0C	SPM1005-1V0C	SPM1006-1V0C
0.8V	SPM1004-0V8C	SPM1005-0V8C	SPM1006-0V8C
0.6V	(NA)	SPM1005-0V6C	SPM1006-0V6C
EVM	EVM1004	EVM1005	EVM1006

To learn more about this product please email PowerModules@us.sumida.com.

For more information on this and other Sumida products, visit www.sumida.com.



Компания «ЭлектроПласт» предлагает заключение долгосрочных отношений при поставках импортных электронных компонентов на взаимовыгодных условиях!

Наши преимущества:

- Оперативные поставки широкого спектра электронных компонентов отечественного и импортного производства напрямую от производителей и с крупнейших мировых складов;
- Поставка более 17-ти миллионов наименований электронных компонентов;
- Поставка сложных, дефицитных, либо снятых с производства позиций;
- Оперативные сроки поставки под заказ (от 5 рабочих дней);
- Экспресс доставка в любую точку России;
- Техническая поддержка проекта, помощь в подборе аналогов, поставка прототипов;
- Система менеджмента качества сертифицирована по Международному стандарту ISO 9001;
- Лицензия ФСБ на осуществление работ с использованием сведений, составляющих государственную тайну;
- Поставка специализированных компонентов (Xilinx, Altera, Analog Devices, Intersil, Interpoint, Microsemi, Aeroflex, Peregrine, Syfer, Eurofarad, Texas Instrument, Miteq, Cobham, E2V, MA-COM, Hittite, Mini-Circuits, General Dynamics и др.);

Помимо этого, одним из направлений компании «ЭлектроПласт» является направление «Источники питания». Мы предлагаем Вам помощь Конструкторского отдела:

- Подбор оптимального решения, техническое обоснование при выборе компонента;
- Подбор аналогов;
- Консультации по применению компонента;
- Поставка образцов и прототипов;
- Техническая поддержка проекта;
- Защита от снятия компонента с производства.



Как с нами связаться

Телефон: 8 (812) 309 58 32 (многоканальный)

Факс: 8 (812) 320-02-42

Электронная почта: org@eplast1.ru

Адрес: 198099, г. Санкт-Петербург, ул. Калинина, дом 2, корпус 4, литера А.