

Features

- Low Insertion Loss, 0.6 dB Typical @ 1.0 GHz
- Fast Switching Speed, 10 ns Typical
- Ultra Low DC Power Consumption
- Integral Static Protection
- 100% Matte Tin Plating over Copper
- Halogen-Free "Green" Mold Compound
- RoHS* Compliant

Description

The MASW6020G is a GaAs MMIC SPST switch die. This die is ideally used where low power consumption is required.

Typical applications include transmit / receive switching, switch matrices and switched filter banks, WLAN IEEE 802.11a and 802.11 b/g systems. Other applications include cordless phones and base stations.

Ordering Information

Part Number	Package
MASW6020G	DIE ¹

1. Die quantity varies.

Absolute Maximum Rating ^{2,3}

Parameter	Absolute Maximum
Control Value (A/B)	-8.5 VDC
Max Input RF Power	+34 dBm (500 MHz - 4 GHz)
Storage Temperature	-65°C to +175°C
Operating Temperature	+175°C

- Exceeding any one or combination of these limits may cause permanent damage to this device.
- M/A-COM Technology Solutions does not recommend sustained operation near these survivability limits.

Pad Layout

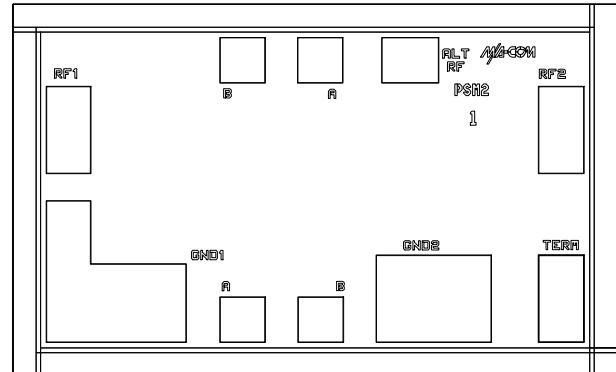

Die Size - Inches (mm)

0.05 x 0.03 x 0.004 (1.270 x 0.770 x 0.250)

Bond Pad Dimensions

Bond Pad	Dimensions - Inches (mm)
RF1, RF2	0.004 x 0.008 (0.100 x 0.200)
Alt RF	0.004 x 0.005 (0.100 x 0.125)
A, B	0.004 x 0.004 (0.100 x 0.100)
GND1	0.012 x 0.007 (0.300 x 0.175)
GND2	0.009 x 0.008 (0.225 x 0.200)
Term	0.004 x 0.008 (0.100 x 0.200)

Schematic

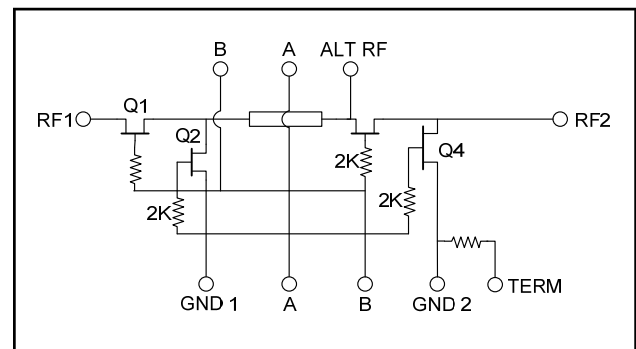

*Restrictions on Hazardous Substances, European Union Directive 2002/95/EC.

ADVANCED: Data Sheets contain information regarding a product M/A-COM Technology Solutions is considering for development. Performance is based on target specifications, simulated results, and/or prototype measurements. Commitment to develop is not guaranteed.
PRELIMINARY: Data Sheets contain information regarding a product M/A-COM Technology Solutions has under development. Performance is based on engineering tests. Specifications are typical. Mechanical outline has been fixed. Engineering samples and/or test data may be available. Commitment to produce in volume is not guaranteed.

• **North America** Tel: 800.366.2266 / Fax: 978.366.2266
 • **Europe** Tel: 44.1908.574.200 / Fax: 44.1908.574.300
 • **Asia/Pacific** Tel: 81.44.844.8296 / Fax: 81.44.844.8298
 Visit www.macomtech.com for additional data sheets and product information.

M/A-COM Technology Solutions Inc. and its affiliates reserve the right to make changes to the product(s) or information contained herein without notice.

Electrical Specifications: 0 / -5 V

Parameter	Test Conditions	Units	Min.	Typ.	Max.
Insertion Loss	DC - 1.0 GHz L/T/H	dB	—	0.8 / 1.0 / 0.9	—
	DC - 2.0 GHz L/T/H		—	0.9 / 1.1 / 1.0	—
	DC - 6.0 GHz L/T/H		—	2.5 / 2.7 / 2.5	—
Isolation	DC - 1.0 GHz L/T/H	dB	—	30 / 63 / 64	—
	DC - 2.0 GHz L/T/H		—	22 / 46 / 52	—
	DC - 6.0 GHz L/T/H		—	11 / 14 / 19	—
VSWR	DC - 1.0 GHz L/T/H	Ratio	—	1.1:1 / 1.1:1 / 1.1:1	—
	DC - 2.0 GHz L/T/H		—	1.3:1 / 1.2:1 / 1.1:1	—
	DC - 6.0 GHz L/T/H		—	2.0:1 / 2.7:1 / 2.0:1	—
Input P1dB	Above 500 MHz - 0/-5V / 0/-8V 100 MHz - 0/-5V / 0/-8V	dBm	— —	+27 / +33 +21 / +26	— —
IP2	Two Tone Input Power up to +5 dBm Above 500 MHz 100 MHz	dBm	—	+68	—
			—	+62	—
IP3	Two Tone Input Power up to +5 dBm Above 500 MHz 100 MHz	dBm	—	+46	—
			—	+40	—
Control Current	V _{IN} Low (0 to -0.2 V) V _{OUT} High (-5 V @ 50 μA Typ to -8 V)	μA	— —	— —	20 300
T-rise, T-fall	10% to 90% RF and 90% to 10% RF	ns	—	10	—
T _{ON} , T _{OFF}	50% control to 90% RF, and 50% control to 10% RF	ns	—	10	—
Transients	(In Band)	mV	—	10	—

Truth Table ^{4,5}

Option	Control Voltage		Switch Condition & Bonding			Ground Bonds		
	A	B	RF1	RF2	ALT	GND1	GND2	Term
T	1	0	on	on		G		G
	0	1	off	off		G		G
L	1	0		on	on	G	G	
	0	1		off	off	G	G	
H	1	0	on	on		G	G	
	0	1	off	off		G	G	

- Differential voltage, V (state 1) -V (state 2), must be 2.5 V minimum.
- 0 = 0 to -0.2 V, 1 = -5 V @ 10 μA typical to -8 V.

Typical Performance

Insertion Loss

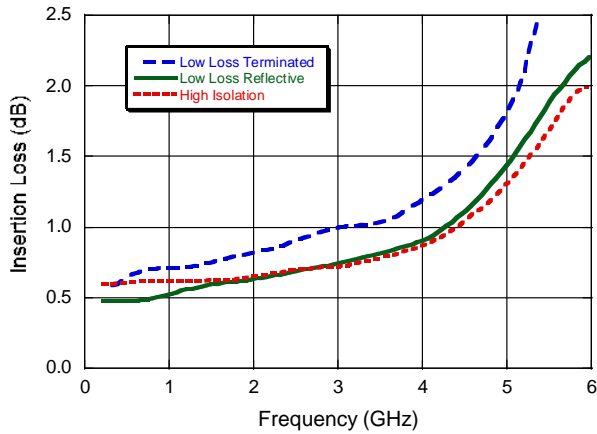

VSWR

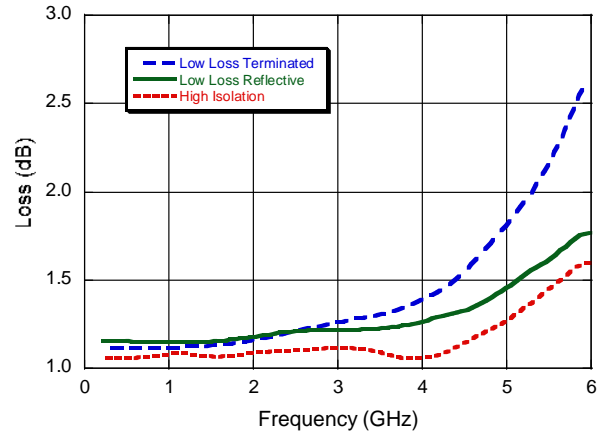

Isolation

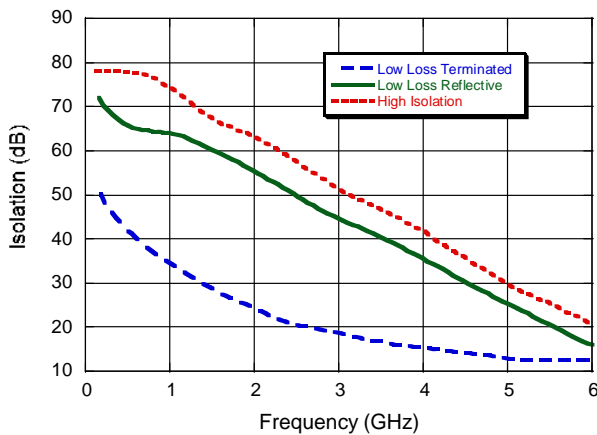

Handling Precautions

Permanent damage to the MASW6020G may occur if the following precautions are not adhered to:

- A. Cleanliness—MASW6020G should be handled in a clean environment. DO NOT attempt to clean unit after the MASW6020G is installed.
- B. Static Sensitivity—All chip handling equipment and personnel should be DC grounded.
- C. Transient—Avoid instrument and power supply transients while bias is applied to the MASW6020G. Use shielded signal and bias cables to minimize inductive pick-up.
- D. Bias—Apply voltage to either of the complementary control ports only when the other is grounded. No port should be allowed to “float”.
- E. General Handling—It is recommended that the MASW6020G chip be handled along the long side of the die with a sharp pair of bent tweezers. DO NOT touch the surface of the chip with fingers or tweezers.

Handling Procedures

Please observe the following precautions to avoid damage:

Static Sensitivity

Gallium Arsenide Integrated Circuits are sensitive to electrostatic discharge (ESD) and can be damaged by static electricity. Proper ESD control techniques should be used when handling these devices.

Mounting

The MASW6020G is back-metallized with Pd/Ni/Au (100/1,000, 10,000 Å) metallization. It can be die-mounted with AuSn eutectic preforms or with thermally conductive epoxy. The package surface should be clean and flat before attachment.

Eutectic Die Attach:

- A. A 80/20 gold/tin preform is recommended with a work surface temperature of approximately 255°C and a tool temperature of 265°C. When not 90/10 nitrogen/hydrogen gas is applied, tool tip temperature should be approximately 290°C.
- B. DO NOT expose the MASW6020G to a temperature greater than 320°C for more than 20 seconds. No more than 3 seconds for scrubbing should be required for attachment.

Epoxy Die Attach:

- A. Apply a minimum amount of epoxy and place the MASW6020G into position. A thin epoxy fillet should be visible around the perimeter of the chip.
- B. Cure epoxy per manufacturer's recommended schedule.
- C. Electrically conductive epoxy may be used by is not required.

Wire Bonding

- A. Ball or wedge with 1.0 mil diameter pure gold wire. Thermosonic wirebonding with a nominal stage temperature of 150°C and a ball bonding force of 40 to 50 grams or wedge bonding force of 18 to 22 grams is recommended. Ultrasonic energy and time should be adjusted to the minimum levels achieve reliable wirebonds.
- B. Wirebonds should be started on the chip and terminated on the package.



Компания «ЭлектроПласт» предлагает заключение долгосрочных отношений при поставках импортных электронных компонентов на взаимовыгодных условиях!

Наши преимущества:

- Оперативные поставки широкого спектра электронных компонентов отечественного и импортного производства напрямую от производителей и с крупнейших мировых складов;
- Поставка более 17-ти миллионов наименований электронных компонентов;
- Поставка сложных, дефицитных, либо снятых с производства позиций;
- Оперативные сроки поставки под заказ (от 5 рабочих дней);
- Экспресс доставка в любую точку России;
- Техническая поддержка проекта, помощь в подборе аналогов, поставка прототипов;
- Система менеджмента качества сертифицирована по Международному стандарту ISO 9001;
- Лицензия ФСБ на осуществление работ с использованием сведений, составляющих государственную тайну;
- Поставка специализированных компонентов (Xilinx, Altera, Analog Devices, Intersil, Interpoint, Microsemi, Aeroflex, Peregrine, Syfer, Eurofarad, Texas Instrument, Miteq, Cobham, E2V, MA-COM, Hittite, Mini-Circuits, General Dynamics и др.);

Помимо этого, одним из направлений компании «ЭлектроПласт» является направление «Источники питания». Мы предлагаем Вам помощь Конструкторского отдела:

- Подбор оптимального решения, техническое обоснование при выборе компонента;
- Подбор аналогов;
- Консультации по применению компонента;
- Поставка образцов и прототипов;
- Техническая поддержка проекта;
- Защита от снятия компонента с производства.



Как с нами связаться

Телефон: 8 (812) 309 58 32 (многоканальный)

Факс: 8 (812) 320-02-42

Электронная почта: org@eplast1.ru

Адрес: 198099, г. Санкт-Петербург, ул. Калинина, дом 2, корпус 4, литера А.