



Datasheet

ZDB5202 Z-Wave Development Board

Document No.:	DSH12436
Version:	5
Description:	This datasheet is for the ZM5202 Z-Wave module based ZDB5202 Z-Wave development board.
Written By:	MVITHANAGE;MVO;MHANSEN;BBR
Date:	2018-03-06
Reviewed By:	OPP;CRASMUSSEN
Restrictions:	None

Approved by:

Date	CET	Initials	Name	Justification
2018-03-06	09:26:06	NTJ	Niels Thybo Johansen	

This document is the property of Silicon Labs. The data contained herein, in whole or in part, may not be duplicated, used or disclosed outside the recipient for any purpose. This restriction does not limit the recipient's right to use information contained in the data if it is obtained from another source without restriction.



REVISION RECORD

Doc. Rev	Date	By	Pages affected	Brief description of changes
4	20160716	MHansen	Section3.2 Appendix A	Updated External NVM to M25PE20 Updated Schematic with correct symbol for ZM5202 and M25PE20
3A	20131122	MVithanage	§3.14, Figure 4.1	Removed blueprint section Removed caption
2C	20130912	MVithanage	§4	Removed reference to schematic
1B	20130603	MVO	§All	Fixed header and footer
1A	20130530	MVithanage	§All	Initial draft
2	20180306	BBR	All	Added Silicon Labs template

Table of Contents

1	ABBREVIATIONS	1
2	INTRODUCTION	1
2.1	Purpose	1
2.2	Audience and prerequisites	1
3	ZDB5202 Z-WAVE DEVELOPMENT BOARD	2
3.1	HW Specifications	2
3.1.1	Application Connector Specification	2
3.2	SPI Interface.....	4
3.3	ADC.....	5
3.4	Power	5
3.5	EMC.....	6
3.6	Antenna	6
3.7	Z-Wave Module Programming	7
3.8	ZM5202 Z-Wave Module Specification	8
3.9	RF Specification	8
3.10	Electrical Specification	8
3.10.1	Absolute Maximum Ratings	9
3.10.2	DC Characteristics	9
3.11	Physical Specification.....	10
3.12	Z-Wave Module Component Placement	11
3.13	Module Naming	12
4	REFERENCES	13

Table of Figures

Figure 3.1	ZDB5202 Z-Wave Development Board.....	2
Figure 3.2	External NVM mounted on ZDB5202.....	4
Figure 3.3	LDO DC/DC Converter Schematic.....	5
Figure 3.4:	ZDB5202 PCB Antenna and SMA Connector.....	7
Figure 3.5	ZDB5202 PCB outline	11
Figure 3.6	(a): ZDB5202 Component Placement (b) ZM5202 Z-Wave Module with Pads and Component Placement.....	11

Table of Tables

Table 3.1:	ZDB5202 Application Connector Layout	2
Table 3.2:	Application Connector Signal Descriptions	3
Table 3.3	SW API / SPI availability.....	4
Table 3.4	ADC input selection	5
Table 3.5	LDO DC/DC Converter Components	5
Table 3.6	Minimum Supply Voltage.....	6
Table 3.7	PCB/Whip Antenna component mount.....	6
Table 3.8	ZM5202 Z-Wave Module Specification.....	8
Table 3.9:	RF Specifications.....	8

Table 3.10: Absolute Maximum Ratings.....	9
Table 3.11 DC Characteristics.....	10
Table 3.12 Physical Specifications	10

1 ABBREVIATIONS

Abbreviation	Explanation
NVM	Non-Volatile Memory
SMA	Sub-Miniature A
HW	Hardware
SW	Software
API	Application Programming Interface
ZDB	Z-Wave Development Board
PCB	Printed Circuit Board

2 INTRODUCTION

2.1 Purpose

The purpose of this datasheet is to describe the ZDB5202 Z-Wave Development Board, which contains the ZM5202 Z-Wave Module, external NVM (Flash), a push-button, HW interface protection circuitry, antenna matching circuitry, PCB antenna and a SMA connector for whip antenna mounting. The ZDB5202 has the same physical form factor as the ZM3102 based ZM3120C Z Wave Module, and the ZM4102 based ZM4120C, which enables easy migration to the new 500 series platform.

2.2 Audience and prerequisites

OEM customers that are using any of the 20cm² form factor Z-Wave Modules from previous generations, and who want to migrate from their existing platform to the new 500 series platform.

3 ZDB5202 Z-WAVE DEVELOPMENT BOARD

The ZDB5202 Z-Wave Development Board (ZDB) contains a ZM5202 Z-Wave Module, external NVM (Flash), a push-button, HW Interface protection circuitry, ADC input selection circuitry, antenna matching circuitry, PCB antenna and a SMA connector for whip antenna mounting. OEM customers who are currently using the ZM1220, ZM2120C, ZM3120C, or ZM4120C Z-Wave Module, and want to migrate to the ZM5202 Z-Wave Module, can use the ZDB5202. The block diagram of the ZDB5202 is shown in Figure 3.1.

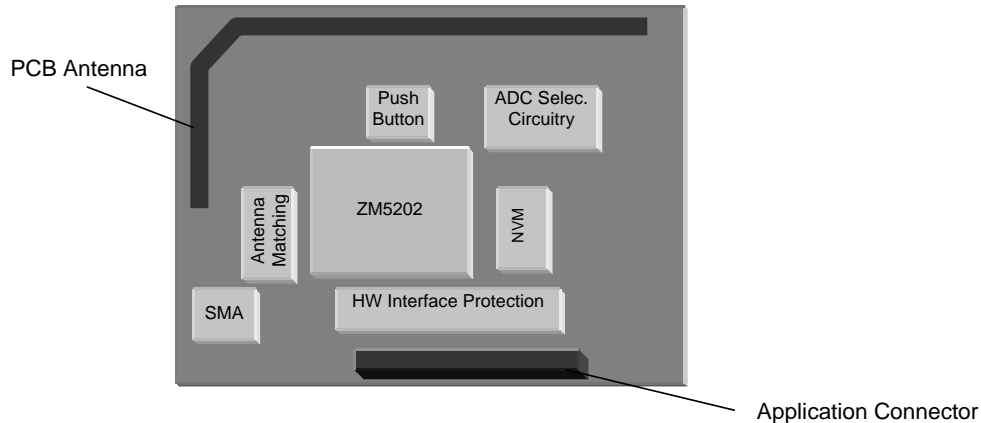

Figure 3.1 ZDB5202 Z-Wave Development Board

3.1 HW Specifications

3.1.1 Application Connector Specification

The Application Connector (J1 in Appendix A) interfacing the ZDB5202 with the Application Module is a 2x10 2mm pitch pin row. The Application Connector signal names are shown in Table 3.1.

Table 3.1: ZDB5202 Application Connector Layout

Pin No.	Pin Name	Pin Name	Pin No.
1	NC	NC	2
3	P3.7 / ADC3 / ZEROX	P1.0 / INT0 / PWM	4
5	P3.6 / ADC2 / TRIAC	GPIO 1.1 / INT1	6
7	AD1_C ² (ADC1 or ADC3)	P0.4	8
9	NC	P2.3 / SPI1 MISO / SPI ISP	10
11	VCC	P2.4 / SPI1 SCK / SPI ISP	12
13	GND	P2.2 / SPI1 MOSI / SPI ISP	14
15	RESET_N	P3.5 / ADC1 / UART0 TX	16
17	+3.3V	P3.4 / ADC0 / UART0 RX	18
19	NC	AD2_C ³ (ADC0)	20

1. Resistors R8, R11, and R14 can select ADC1 or ADC3. By default, none of them are mounted.
2. Pin 20 is per default not connected to the RXD/ADC0 signal.

Table 3.2: Application Connector Signal Descriptions

Name	Pin#	I/O	Description
+3.3V	17	Power	Module 3.3V supply input voltage.
VCC	11	Power	Supply input voltage to the Low-Drop Out (LDO) regulator.
ADC[3:0]	18, 20, 7, 16, 5, 3, 7,	I	Analog-to-Digital Converter input. The ADC is 12/8 bit and can use +3.3V, an internal or an external voltage as reference. ADC0: input ADC1: input ADC2: input or lower reference voltage ADC3: input or higher reference voltage See section 3.3 for further description.
GND	13	Power	Ground signal
INT[1:0]	6, 4	I	Interrupt: The signals can be either level or edge triggered. When in power down mode, the ZDB5202's MCU can be woken up by asserting INT1 (level triggered only).
P0.4, P[1.0-1.1], P[2.2-2.4], P[3.4-3.7]	8, 4, 6, 14, 10, 12, 18, 16, 5, 3	I/O	In/Out: General purpose I/O signal.
MISO ¹	10	I/O	Master-In-Slave-Out SPI interface: output in slave mode operation and input in master mode operation.
MOSI ¹	14	I/O	Master Out Slave In SPI interface: input in slave mode operation and output in master mode operation.
PWM	4	O	Pulse Width Modulator Output: Used for frequency variation applications.
RESET_N	15	I	Reset: Active low reset with integrated Power-On-Reset and Brown-out detection circuitry.
RXD	18	I	UART Receive Data: Supports up to 230.4kbps.
SCK ¹	12	I/O	SPI Clock: Can be used as either master SPI clock output or slave SPI clock input.
TRIAC	5	O	TRIAC Control: A Dimmer implemented on the ZM5202 Z-Wave Module can control a TRIAC on the Application Module like light dimmer modules etc.
TXD	16	O	UART Transmit Data: Supports up to 230.4kbps.
ZEROX	3	I	Zero Cross Detection: Used on Dimmer modules for detecting 120/240V zero crossing.

1. Please note that the SPI interface (MISO, MOSI and SCK) is not available for the Application SW in some Z-Wave protocol API's, see [2].

All signals in Table 3.2 except VCC, +3.3V, and GND are connected through a 1kohm resistor to the corresponding signals on the ZM5202 Z-Wave Module (U1 in Appendix A). A detailed description of these signals is given in the ZM5202 Z-Wave Module datasheet [1].

3.2 SPI Interface

The SPI interface is in some SW API's used by the protocol to store routing tables etc in an external NVM (Flash). When these SW API's are used, the Application SW must *not* use the SPI interface. Table 3.3 lists the available SW API's and shows in which the SPI can be used by the Application SW.

Table 3.3 SW API / SPI availability

SW API	External NVM used by Protocol API
Slave	No
Routing Slave	No
Enhanced Slave	Yes
Controller	Yes
Static Controller	Yes
Installer	Yes
Bridge	Yes

The SPI interface is used to access the external NVM and the P0.4 signal (J1 pin 8) is used by the Z-Wave Protocol as external NVM Chip Select. If the external NVM is used by the protocol the signal P0.4 may not be used by the application SW and may not be connected to other circuitry through J1 pin 8 on the Application Module. To assure proper control of the external NVM chip select signal during reset and power-up, a pull up resistor on the P0.4 is implemented as shown in Figure 3.2.

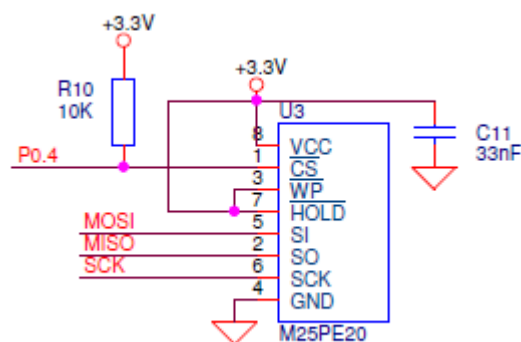

Figure 3.2 External NVM mounted on ZDB5202

Only a part of the external NVM is used for protocol data storage. The Application SW can use the remaining memory area using an API call (see [2]). The external NVM memory area requirements of the different protocol API's are described in [2].

3.3 ADC

The two ADC pins 'AD1_C' and AD2_C' on the Application connector (J1) can be used to access all four ADC inputs on the ZDB5202. Different resistor mounting configurations can be used as described in Table 3.4.

Table 3.4 ADC input selection

Application Connector Signal	Reference Designator	ADC input
AD1_C	Mount R8 and R11	ADC1
	Mount R8 and R14	ADC3
AD2_C	Unmount R6 and mount R19	ADC0
ZEROX	Mount L4 and R1	ADC3
TRIAC	Mount L5 and R2	ADC2

3.4 Power

The ZDB5202 has a mounting option for a Low-Drop-Out (LDO) voltage regulator, which can be mounted when having supply voltages greater than 3.3V on the Application Module.

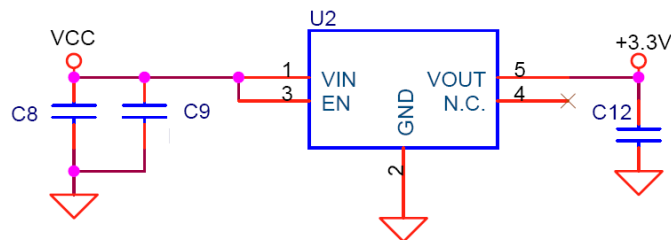

Figure 3.3 LDO DC/DC Converter Schematic

Table 3.5 LDO DC/DC Converter Components

Reference Designator	Description	Vendor / Vendor P/N
U2	Vreg, 3.3V, LDO 200mV, 150mA, SO23-5	Analogic Tech: AAT3221IGV-3.3-T1
C8	Cap. Cer., 20%, 0603, 4.7uF, Y5V/Z5U, 10V	Any according to spec
C12	Cap. Cer., 20%, 0402, 33nF, X7R, 50V	Any according to spec
C9	Cap. Cer., 20%, 0402, 33nF, X7R, 50V	Any according to spec
L1*	Induct., Ferrite Bead, 0805, 330R@100MHz	Murata: BLM21AG331SN1D

* Ferrite bead connects the pin 11 (VCC) on the Application Connector to the Voltage Regulator

The voltage regulator specified in the table above have a drop out of 200mV meaning that the voltage supplied by the Application Module must be greater than +3.5V. The supply voltage from the Application Module must then be supplied to the ZDB5202 via Application connector pin 11 (VCC) and the passive components listed in Table 3.5 must be mounted (see Figure 3.3).

When implementing the ZDB5202 together with noisy power electronics such as light dimmer products, motor control products etc. it is recommended to use the LDO regulator as it is a cheap way to attenuate

noise from the Application Module power supply. The Analogic Tech voltage regulator listed in the table above has a typical Power Supply Rejection Ratio of 50dB at 100Hz. Other footprint compatible voltage regulators can also be used.

The minimum supply voltage for the ZDB5202 depends on whether the external NVM is mounted and what type of external NVM is mounted, as listed in Table 3.6. The ZDB5202 has been mounted with a Micron 2Mbit SPI based external Flash, although an Atmel 128kbit SPI based external EEPROM can also be used.

Table 3.6 Minimum Supply Voltage

External NVM	Minimum Supply Voltage
Not Mounted	2.3V
M25PE10-VMN6P	2.7V
AT25xxxxN-10Sx-2.7	2.7V
AT25xxxxN-10Sx-1-8	2.3V

3.5 EMC

As default, a 1000R@100MHz Ferrite Bead is mounted between the Application Connector +3.3V and module +3.3V (L2 in Appendix A) to reduce noise from the Application Circuitry.

As default 1000R@100MHz Ferrite Beads are mounted in series with the TRIAC signal and the ZEROX signal (L4 and L5) to reduce the noise from noisy TRIAC circuitry. Two zero ohm resistors can be mounted instead in applications where TRIAC and ZEROX is not used for power electronic control.

3.6 Antenna

In order to implement the ZDB5202 in various products, different types of antennas can be implemented to get the best RF performance, i.e. range and reliability. The ZDB5202 is equipped with a PCB antenna and a SMA connector for Whip antenna mounting.

Table 3.7 PCB/Whip Antenna component mount

Antenna	E	U	H
PCB	R4: NM R12: 5.6pF C4: 0ohm C6: 3.6nH C7: NM	R4: NM R12: 3.3pF C4: 0ohm C6: 3.9nH C7: NM	R4: NM R12: 3.3pF C4: 0ohm C6: 3.9nH C7: NM
Whip (SMA)	R4: 10nH R12: NM C4: 0ohm C6: 3.3pF C7: NM	R4: 10nH R12: NM C4: 0ohm C6: 3.3pF C7: NM	R4: 10nH R12: NM C4: 0ohm C6: 3.3pF C7: NM

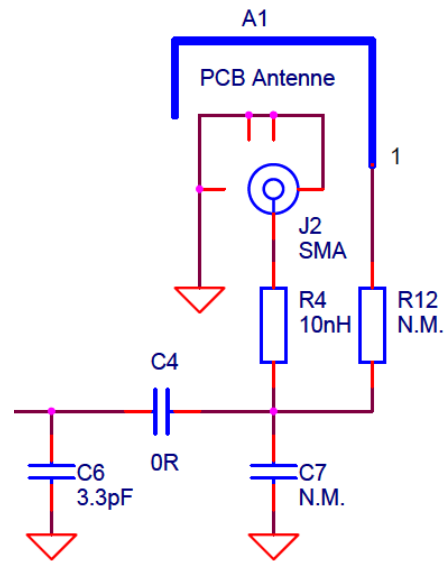

Figure 3.4: ZDB5202 PCB Antenna and SMA Connector

Please note that the antenna matching components listed in Table 3.7 are found and verified when the ZDB5202 is mounted on the ZDP03A Z-Wave Development Platform. If the ZDB5202 is used in another application it may be necessary to design a new matching circuit for best RF performance.

Three versions of the ZDB5202 are currently available: E/U/H with Whip antenna. Please refer to [4], [5], and [6].

A description of relevant antenna types for short range devices are given in [3].

3.7 Z-Wave Module Programming

The ZDB5202 is programmed using the SPI interface and the RESET_N signal. For programming instruction and recommended programming tool(s) see [1] and [2].

3.8 ZM5202 Z-Wave Module Specification

Table 3.8 ZM5202 Z-Wave Module Specification

Item	Description
MCU Type	Optimized 8-bit 8051 MCU core.
MCU speed	32 MHz (integrated clock divider, 32MHz external crystal)
Flash	128kByte Programmed through the SPI interface.
SRAM	16kByte
SRAM (CPU)	256Byte
MCU Peripherals	12/8-bit ADC, UART, SPI, 3x16 bit timers one with PWM mode, Watch Dog Timer, Wake Up Timer, Power-on Reset/Brown-Out Detector.
Interrupt sources	Internal and external.
Crystal	System Clock: 32 MHz, $\pm 10\text{ppm}@25^\circ\text{C}$, $\pm 10\text{ppm}@-15^\circ\text{C}$ to $+85^\circ\text{C}$, 3ppm aging per 5 years. Alternative: 32 MHz, $\pm 8\text{ppm}@25^\circ\text{C}$, $\pm 8\text{ppm}@-15^\circ\text{C}$ to $+85^\circ\text{C}$, 3ppm aging per year.

3.9 RF Specification

Table 3.9: RF Specifications

RF Parameter ¹	Description
RF Data Rate	9.6 kbps 40 kbps 100 kbps
Typical RF receiver sensitivity	-103.0dBm @ 9.6 kbps -99.0dBm @ 40 kbps -91.8dBm @ 100 kbps
Typical RF Output Power	-26.3dBm to +2.0dBm
Typical Range	Indoor > 40 meters line of sight, in unobstructed environment Outdoor > 100 meters line of sight
RF Input/Output Impedance	50ohm @ respective E/U/H frequencies
RF regulatory	ACMA Compliance CE Compliance FCC Compliance IC Compliance MIC Compliance

1. Test Conditions: ZDB5202 with quarter wavelength monopole whip antenna mounted on ZDP03A Z-Wave Development Platform.

3.10 Electrical Specification

The “Absolute Maximum Ratings” specifies the conditions in which the ZDB5202 is guaranteed not to be damaged, but correct operations are not guaranteed. Exceeding the “Absolute Maximum Ratings” may destroy the ZDB5202. See “DC Characteristics” for guaranteed operation limits.

3.10.1 Absolute Maximum Ratings

Table 3.10: Absolute Maximum Ratings

Electrical	Value
Operating Temperature	-10°C to +85°C
Main Supply Voltage	-0.3V to +3.6V
Minimum Voltage Applied On Any I/O	-0.3V
Maximum Voltage Applied On Any I/O	+3.6V

3.10.2 DC Characteristics

The following DC characteristics are for the ZDB5202 at an Ambient Temperature = 25°C and Supply Voltage = 3.3V (unless otherwise noted).

Table 3.11 DC Characteristics

Symbol	Parameter	Condition	Min	Typ	Max	Units
+3.3V	Main Supply voltage ⁽¹⁾		2.3	3.3	3.6	V
R _{AC}	Application Connector Serial Resistor	All signals	0.9	1.0	1.1	KΩ
I _C ⁽²⁾	Continuous Output Current	One GPIO	-8.0		+8.0	mA
I _C ⁽²⁾	Continuous Output Current	One GPIO (<i>P3.4 to P3.7</i>)	-16.0		+16.0	mA
I _{CTOT} ⁽²⁾	Total continuous output source/sink current	All GPIO	-120.0		+120.0	mA
I _{CC}	Transmitting ⁽³⁾	Pout = 0dBm (Setting: 32) Pout = +2dBm (Setting: 63)		36.0 41.0		mA
	Receiving ⁽⁴⁾			32.0		mA
	Power Down ⁽⁵⁾			2.0		μA
T _{OP}	Operating Temperature		-10.0		+85.0	°C

(1) Minimum supply voltage depends on external NVM selection if mounted. See Table 3.6.

(2) If serial 1K ohm resistor is replaced with 0 ohm resistor.

(3) The transceiver is in transmit mode with the MCU running. The ADC is off. The crystal is 32MHz.

(4) The transceiver is in receive mode with the MCU running. The ADC is off. The crystal is 32MHz.

(5) The ADC, transceiver, MCU and flash are shut down. The chip can be woken by brownout, an external reset pulse, external interrupt (if enabled) or periodical wakeup by WUT (if enabled). POR cannot be disabled. External NVM standby current added to ZDB5202 power down current.

3.11 Physical Specification

Table 3.12 Physical Specifications

Physical	Description
Dimension (H x W x D)	8 mm x 50 mm x 40 mm

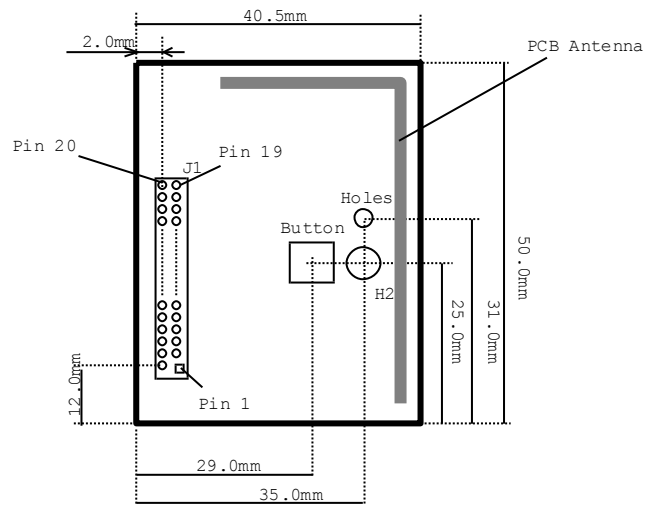

Figure 3.5 ZDB5202 PCB outline

The Application Connector is a standard 2mm pitch 2x10 pin-row. The pin hole is a $\text{Ø}0.9\text{mm}$ plated hole. When implementing the ZDB5202 in a product together with an Application Module any metallic objects must be minimum 10mm from the PCB antenna.

3.12 Z-Wave Module Component Placement

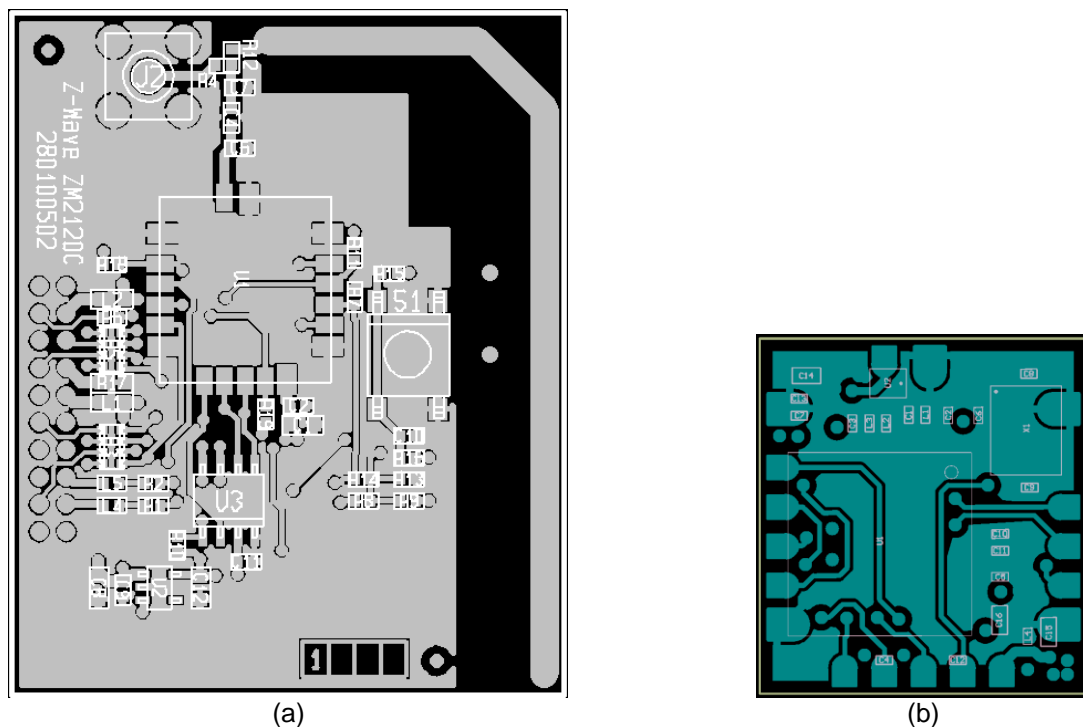

Figure 3.6 (a): ZDB5202 Component Placement
(b) ZM5202 Z-Wave Module with Pads and Component Placement

The ZM5202 Z-Wave Module footprint on the ZDB5202 contains 19 pads including the discontinued high voltage pad used for programming. The ZM5202 Z-Wave Module is Flash based and hence do not require a high voltage during programming. It contains only 18 pads as shown in Figure 3.6b. The

ZM5202 Z-Wave Modules pads 16, 17, 18 will be connected to the pads 17, 18, 19 on the ZDB5202. The signals used for interconnection between ZDB5202 and ZM5202 Z-Wave Module are shown in the schematic in Appendix A.

3.13 Module Naming

The following naming convention is used by Silicon Labs:

Z-Wave Module	Z-Wave Development Board
<p>ZMGVSS</p> <ul style="list-style-type: none"> ZM – Z-Wave Module G – Z-Wave Generation V – Module Variant SS – Size in cm² <p>e.g.: ZM5202</p>	<p>ZDBGVSS</p> <ul style="list-style-type: none"> ZDB – Z-Wave Development Board <p>Mounted Module:</p> <ul style="list-style-type: none"> G – Z-Wave Generation V – Module Variant SS – Size in cm² <p>e.g.: ZDB5202</p>

4 REFERENCES

- [1] Silicon Labs, DSH12435, Datasheet, ZM5202 Z-Wave Module
- [2] Silicon Labs, INS11681, Instruction, 500 Series Z-Wave Chip Programming Mode
- [3] Silicon Labs, APL10045, Application Note, Antennas for Short Range Devices
- [4] Silicon Labs, BOM12396, Bill of Material, ZDB5202 EU, SMA, BOM-370101640
- [5] Silicon Labs, BOM12474, Bill of Material, ZDB5202 US, SMA, BOM-370101890
- [6] Silicon Labs, BOM12475, Bill of Material, ZDB5202 HK, SMA, BOM-370101900

APPENDIX A SCHEMATIC

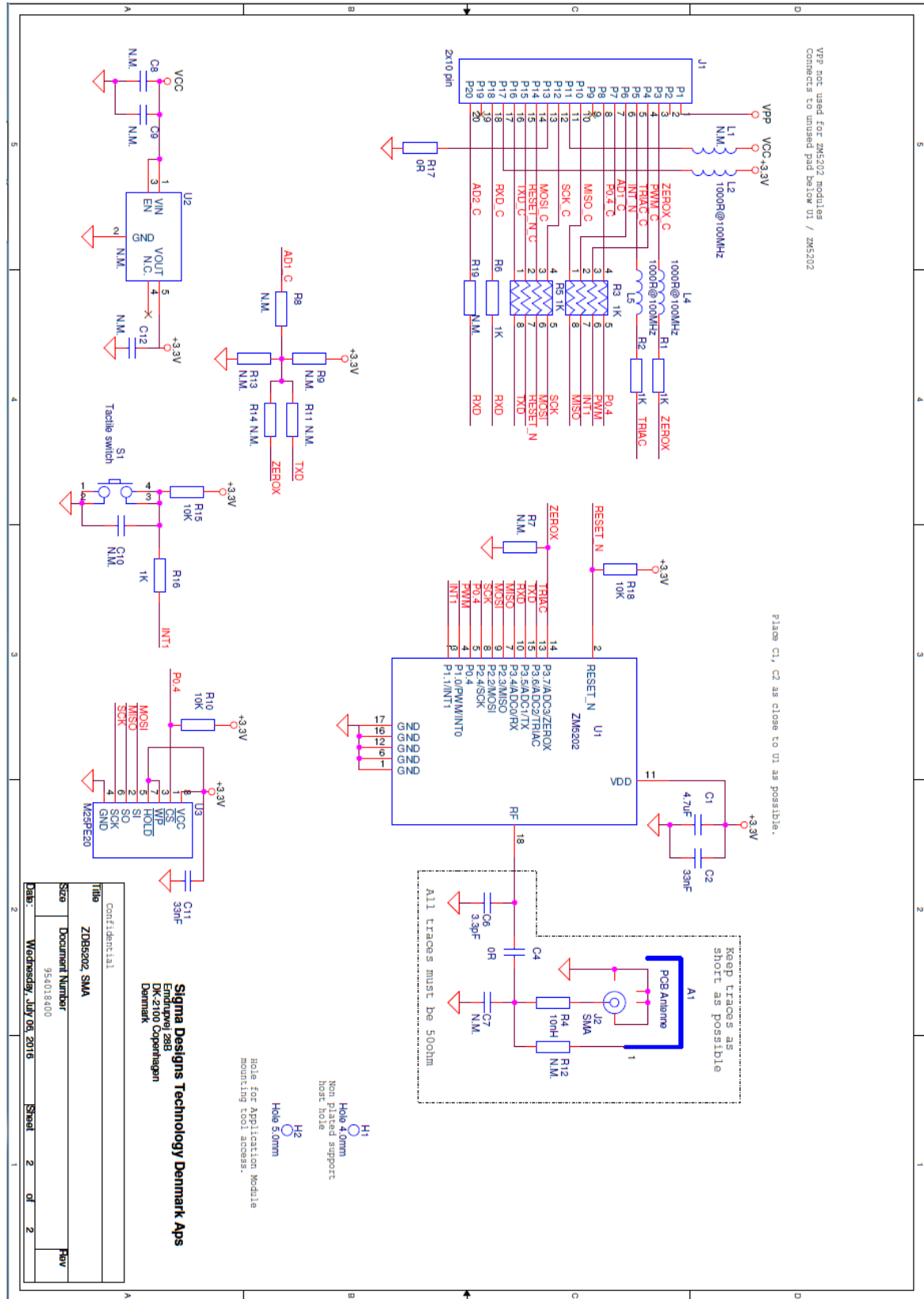

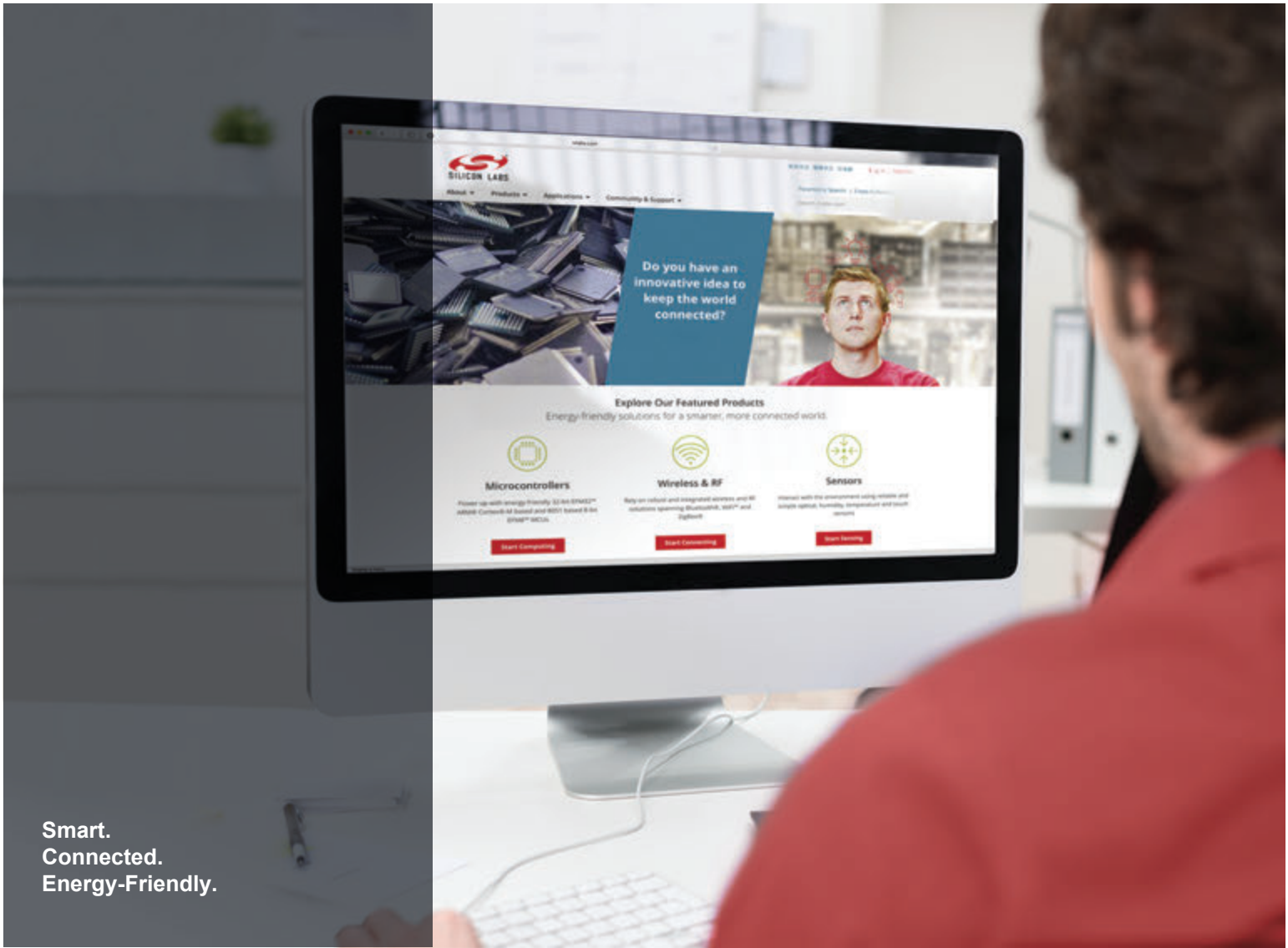

Smart.
Connected.
Energy-Friendly.



Products
www.silabs.com/products

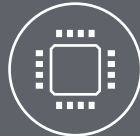

Quality
www.silabs.com/quality



Support and Community
community.silabs.com

Disclaimer

Silicon Labs intends to provide customers with the latest, accurate, and in-depth documentation of all peripherals and modules available for system and software implementers using or intending to use the Silicon Labs products. Characterization data, available modules and peripherals, memory sizes and memory addresses refer to each specific device, and "Typical" parameters provided can and do vary in different applications. Application examples described herein are for illustrative purposes only. Silicon Labs reserves the right to make changes without further notice and limitation to product information, specifications, and descriptions herein, and does not give warranties as to the accuracy or completeness of the included information. Silicon Labs shall have no liability for the consequences of use of the information supplied herein. This document does not imply or express copyright licenses granted hereunder to design or fabricate any integrated circuits. The products are not designed or authorized to be used within any Life Support System without the specific written consent of Silicon Labs. A "Life Support System" is any product or system intended to support or sustain life and/or health, which, if it fails, can be reasonably expected to result in significant personal injury or death. Silicon Labs products are not designed or authorized for military applications. Silicon Labs products shall under no circumstances be used in weapons of mass destruction including (but not limited to) nuclear, biological or chemical weapons, or missiles capable of delivering such weapons.

Trademark Information

Silicon Laboratories Inc.®, Silicon Laboratories®, Silicon Labs®, SiLabs® and the Silicon Labs logo®, Bluegiga®, Bluegiga Logo®, Clockbuilder®, CMEMS®, DSPLL®, EFM®, EFM32®, EFR®, Ember®, Energy Micro, Energy Micro logo and combinations thereof, "the world's most energy friendly microcontrollers", Ember®, EZLink®, EZRadio®, EZRadioPRO®, Gecko®, ISOmodem®, Micrium, Precision32®, ProSLIC®, Simplicity Studio®, SiPHY®, Telegesis, the Telegesis Logo®, USBXpress®, Zentri, Z-Wave and others are trademarks or registered trademarks of Silicon Labs. ARM, CORTEX, Cortex-M3 and THUMB are trademarks or registered trademarks of ARM Holdings. Keil is a registered trademark of ARM Limited. All other products or brand names mentioned herein are trademarks of their respective holders.



SILICON LABS

Silicon Laboratories Inc.
400 West Cesar Chavez
Austin, TX 78701
USA

<http://www.silabs.com>



Компания «ЭлектроПласт» предлагает заключение долгосрочных отношений при поставках импортных электронных компонентов на взаимовыгодных условиях!

Наши преимущества:

- Оперативные поставки широкого спектра электронных компонентов отечественного и импортного производства напрямую от производителей и с крупнейших мировых складов;
- Поставка более 17-ти миллионов наименований электронных компонентов;
- Поставка сложных, дефицитных, либо снятых с производства позиций;
- Оперативные сроки поставки под заказ (от 5 рабочих дней);
- Экспресс доставка в любую точку России;
- Техническая поддержка проекта, помощь в подборе аналогов, поставка прототипов;
- Система менеджмента качества сертифицирована по Международному стандарту ISO 9001;
- Лицензия ФСБ на осуществление работ с использованием сведений, составляющих государственную тайну;
- Поставка специализированных компонентов (Xilinx, Altera, Analog Devices, Intersil, Interpoint, Microsemi, Aeroflex, Peregrine, Syfer, Eurofarad, Texas Instrument, Miteq, Cobham, E2V, MA-COM, Hittite, Mini-Circuits, General Dynamics и др.);

Помимо этого, одним из направлений компании «ЭлектроПласт» является направление «Источники питания». Мы предлагаем Вам помощь Конструкторского отдела:

- Подбор оптимального решения, техническое обоснование при выборе компонента;
- Подбор аналогов;
- Консультации по применению компонента;
- Поставка образцов и прототипов;
- Техническая поддержка проекта;
- Защита от снятия компонента с производства.



Как с нами связаться

Телефон: 8 (812) 309 58 32 (многоканальный)

Факс: 8 (812) 320-02-42

Электронная почта: org@eplast1.ru

Адрес: 198099, г. Санкт-Петербург, ул. Калинина, дом 2, корпус 4, литера А.