

REVISIONS					
REV	ECO	DESCRIPTION	DATE	BY	APPR
A1	-	RELEASE NEW DRAWING	15JUN18	SULLEN	TOMMY

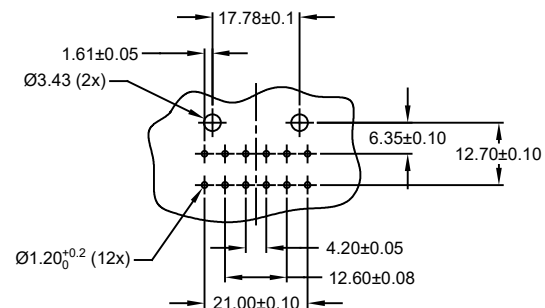
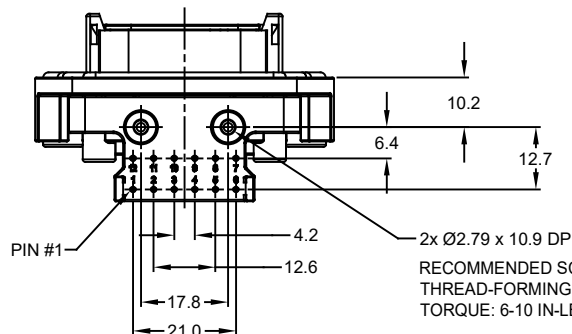
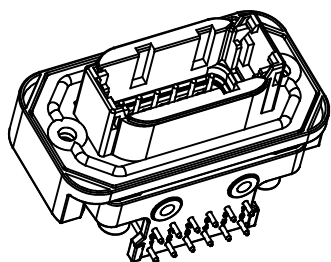
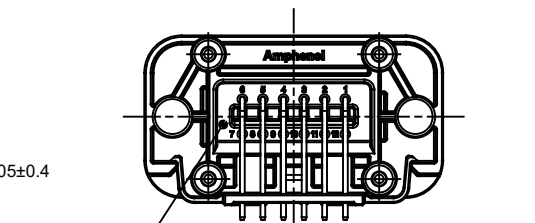
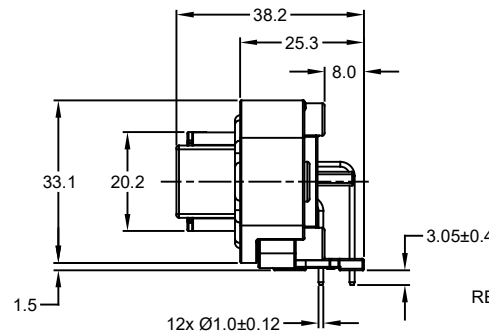
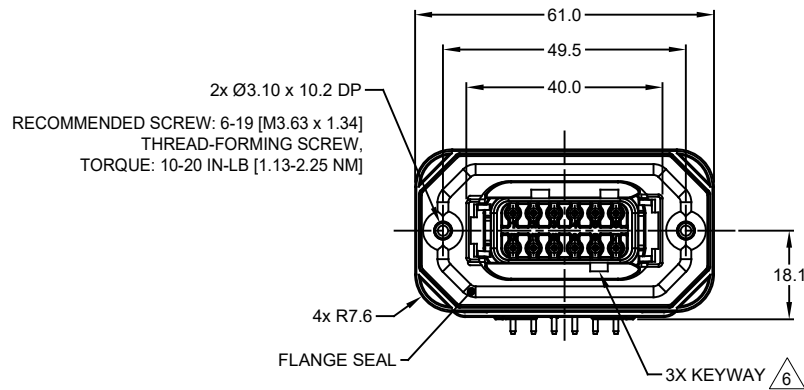

RECOMMENDED PCB LAYOUT
VIEW FROM COMPONENTS
SIDE OF PCB

NOTES: UNLESS OTHERWISE SPECIFIED

- MATERIAL:
HOUSING: THERMOPLASTIC, GREY
SEAL: SILICONE RUBBER
CONTACT: COPPER ALLOY
- CONTACT PLATING: SEE SHEET 2
- MODIFICATIONS: FLANGE; RA PCB MOUNT
- SPECIFICATIONS:
4.1 CURRENT RATING: 7.5 AMPS
4.2 OPERATING TEMPERATURE: -55°C TO +125°C
4.3 DIELECTRIC WITHSTANDING VOLTAGE: LESS THAN 2 MILLIAMPS CURRENT LEAKAGE @ 1500 VOLTS AC
4.4 INSULATION RESISTANCE: 1000 MEGOHMS MIN @ 25°C
4.5 MOISTURE RESISTANCE: IP67 (MATED CONDITION)
4.6 MATING CYCLE DURABILITY: 100 CYCLES
4.7 RoHS COMPLIANT

- MATING PART: ATM06-12SX-
(X = A,B,C,D KEYS ; * = MODIFICATIONS AND COLORS)
- SEE SHEET 2 FOR OTHER KEY ARRANGEMENTS AND COLORS
- ALL DIMENSIONS ARE FOR REFERENCE USE ONLY

ATM13-12PX-BMXX		DESCRIPTION		ITEM
PART NUMBER		DESCRIPTION		ITEM
QUANTITY MATERIALS LIST				
UNLESS OTHERWISE SPECIFIED				
1) All dimensions are in metric(mm).				
2) Tolerances are as follows:				
1 PL DEC ±0.30 Fractions ±1/64				
2 PL DEC ±0.15 Angles ±1°				
3 PL DEC ±0.08				
3) Note reference =				
SIGNATURES		DATE		 Sine Systems - www.amphenol-sine.com 44724 Morley Drive Clinton Township, MI 48036
DRAWN: SULLEN,ZHANG		15JUN18		
CHECKED: ORIONLI		15JUN18		
ENGINEER:				
APPROVAL: TOMMY,XIE		15JUN18		PCB MOUNT RECEPTACLE 12PIN, RA FLANGE, ATM SERIES
CUSTOMER:				
MATERIAL SPECIFICATIONS:				
PROCESS SPECIFICATIONS:		THIS DRAWING IS SUPPLIED FOR INFORMATION ONLY. DESIGN FEATURES, SPECIFICATIONS AND PERFORMANCE DATA SHOWN HEREON ARE THE PROPERTY OF THE AMPHENOL CORPORATION. NO RIGHTS OF REPRODUCTION ARE IMPLIED. ALL DIMENSIONS ARE SUBJECT TO NORMAL MANUFACTURING VARIATIONS.		SIZE: B C- TYPE: ATM13-12PX-BMXX DWG NO.: SCALE: NONE REVISION: A1
NEXT ASSY:		SHEET 1 OF 2		

TITLE: PCB MOUNT RECEPTACLE 12PIN, RA FLANGE, ATM SERIES
DWG NO.: ATM13-12PX-BMXX
REV: A1
SH: 1
OF: 2

REVISIONS					
REV	ECO	DESCRIPTION	DATE	BY	APPR
A1	-	RELEASE NEW DRAWING	15JUN18	SULLEN	TOMMY

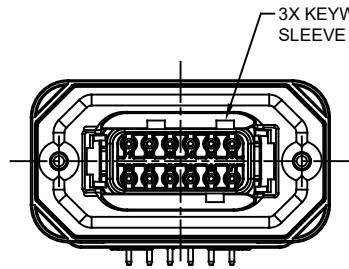

ATM13-12PA-BMXX
KEY A

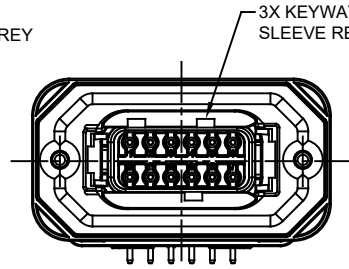

ATM13-12PB-BMXX
KEY B

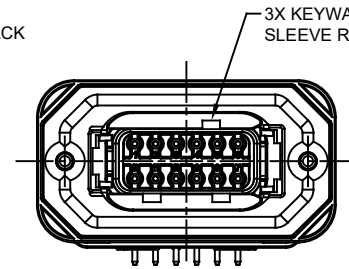

ATM13-12PC-BMXX
KEY C

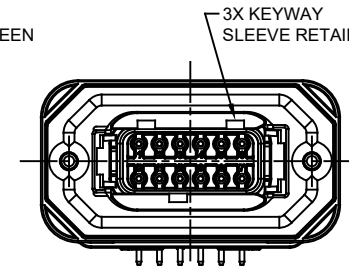

ATM13-12PD-BMXX
KEY D

ATM13-12PA-BMXX VARIANTS		
CONTACT PLATING	POTTING OR NOT IN RESERVOIR	PART NUMBER
GOLD	NO POTTING	ATM13-12PA-BM01
GOLD	POTTING	ATM13-12PA-BM02
TIN	NO POTTING	ATM13-12PA-BM03
TIN	POTTING	ATM13-12PA-BM04

ATM13-12PB-BMXX VARIANTS		
CONTACT PLATING	POTTING OR NOT IN RESERVOIR	PART NUMBER
GOLD	NO POTTING	ATM13-12PB-BM01
GOLD	POTTING	ATM13-12PB-BM02
TIN	NO POTTING	ATM13-12PB-BM03
TIN	POTTING	ATM13-12PB-BM04

ATM13-12PC-BMXX VARIANTS		
CONTACT PLATING	POTTING OR NOT IN RESERVOIR	PART NUMBER
GOLD	NO POTTING	ATM13-12PC-BM01
GOLD	POTTING	ATM13-12PC-BM02
TIN	NO POTTING	ATM13-12PC-BM03
TIN	POTTING	ATM13-12PC-BM04

ATM13-12PD-BMXX VARIANTS		
CONTACT PLATING	POTTING OR NOT IN RESERVOIR	PART NUMBER
GOLD	NO POTTING	ATM13-12PD-BM01
GOLD	POTTING	ATM13-12PD-BM02
TIN	NO POTTING	ATM13-12PD-BM03
TIN	POTTING	ATM13-12PD-BM04

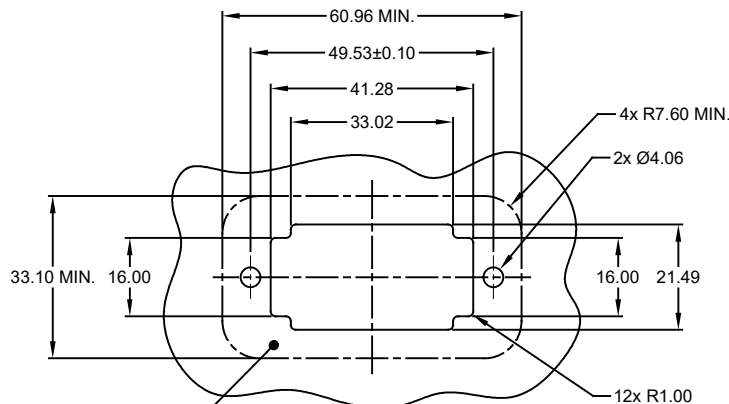

INTERNAL SEALING SURFACE
FINISH TO BE $\sqrt{3.2}$ OR BETTER

RECOMMENDED PANEL
CUTOUT

ATM13-12PX-BMXX		DESCRIPTION		ITEM
QUANTITY	PART NUMBER	MATERIALS LIST		
UNLESS OTHERWISE SPECIFIED: 1) All dimensions are in metric(mm). 2) Tolerances are as follows: 1 PL DEC ±0.30 Fractions ±1/64 2 PL DEC ±0.15 Angles ±1° 3 PL DEC ±0.08				
SIGNATURES		DATE		
DRAWN: SULLEN,ZHANG		15JUN18		
CHECKED: ORION,LI		15JUN18		
ENGINEER:				
APPROVAL: TOMMY,XIE		15JUN18		
CUSTOMER:				
MATERIAL SPECIFICATIONS:		THIS DRAWING IS SUPPLIED FOR INFORMATION ONLY. DESIGN FEATURES, SPECIFICATIONS AND PERFORMANCE DATA SHOWN HEREON ARE THE PROPERTY OF THE AMPHENOL CORPORATION. NO RIGHTS OF REPRODUCTION ARE IMPLIED. ALL DIMENSIONS ARE SUBJECT TO NORMAL MANUFACTURING VARIATIONS.		
PROCESS SPECIFICATIONS:				
NEXT ASSY:				
SIZE	TYPE	DWG NO.	REVISION	
B	C-	ATM13-12PX-BMXX	A1	
SCALE	NONE			SHEET 2 OF 2

TITLE: PCB MOUNT RECEPTACLE 12PIN RA FLANGE, ATM SERIES
DWG NO: ATM13-12PX-BMXX
REV: A1
SH: 2
OF: 2



Компания «ЭлектроПласт» предлагает заключение долгосрочных отношений при поставках импортных электронных компонентов на взаимовыгодных условиях!

Наши преимущества:

- Оперативные поставки широкого спектра электронных компонентов отечественного и импортного производства напрямую от производителей и с крупнейших мировых складов;
- Поставка более 17-ти миллионов наименований электронных компонентов;
- Поставка сложных, дефицитных, либо снятых с производства позиций;
- Оперативные сроки поставки под заказ (от 5 рабочих дней);
- Экспресс доставка в любую точку России;
- Техническая поддержка проекта, помощь в подборе аналогов, поставка прототипов;
- Система менеджмента качества сертифицирована по Международному стандарту ISO 9001;
- Лицензия ФСБ на осуществление работ с использованием сведений, составляющих государственную тайну;
- Поставка специализированных компонентов (Xilinx, Altera, Analog Devices, Intersil, Interpoint, Microsemi, Aeroflex, Peregrine, Syfer, Eurofarad, Texas Instrument, Miteq, Cobham, E2V, MA-COM, Hittite, Mini-Circuits, General Dynamics и др.);

Помимо этого, одним из направлений компании «ЭлектроПласт» является направление «Источники питания». Мы предлагаем Вам помощь Конструкторского отдела:

- Подбор оптимального решения, техническое обоснование при выборе компонента;
- Подбор аналогов;
- Консультации по применению компонента;
- Поставка образцов и прототипов;
- Техническая поддержка проекта;
- Защита от снятия компонента с производства.



Как с нами связаться

Телефон: 8 (812) 309 58 32 (многоканальный)

Факс: 8 (812) 320-02-42

Электронная почта: org@eplast1.ru

Адрес: 198099, г. Санкт-Петербург, ул. Калинина, дом 2, корпус 4, литера А.