

DATA SHEET

SKY12353-470LF: 10 MHz - 1.0 GHz Six-Bit Digital Attenuator with Driver (0.5 dB LSB, 31.5 dB Range)

Applications

- Cellular base stations
- Wireless data transceivers
- Broadband systems

Features

- Attenuation: 31.5 dB with 0.5 dB LSB
- Onboard, low-noise CMOS driver
- Excellent RF noise floor
- Single 5 V supply
- Very low DC power consumption
- Single, positive control for each bit
- Small, QFN (32-pin, 5 x 5 mm) package (MSL1, 260 °C per JEDEC J-STD-020)



Skyworks Pb-free products are compliant with all applicable legislation. For additional information, refer to *Skyworks Definition of Lead (Pb)-Free*, document number SQ04-0073.

Description

The SKY12353-470LF is a six-bit digital GaAs attenuator with an onboard, low-noise CMOS driver. This attenuator offers excellent performance from 10 MHz to 1.0 GHz, which makes it ideal for IF and RF level control applications.

The SKY12353-470LF contains an onboard CMOS driver circuit that accepts CMOS logic levels at the six control inputs and produces a negative supply voltage to control the GaAs attenuator.

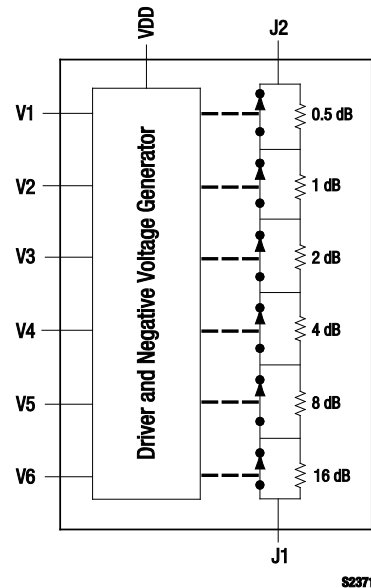

Figure 1. SKY12353-470LF Block Diagram

The device has excellent linearity for compatibility with non-constant envelope signals such as WCDMA and OFDM. The six attenuation bits are binary weighted with an LSB of 0.5 dB and a total nominal attenuation range of 31.5 dB. The device also has excellent attenuation accuracy and is monotonic. The low-noise CMOS driver enables a very low RF noise floor, typically -100 dBm.

The device is provided in a 5 x 5 mm, 32-pin Quad Flat No-Lead (QFN) package. A functional block diagram is shown in Figure 1. The pin configuration and package are shown in Figure 2. Signal pin assignments and functional pin descriptions are provided in Table 1.

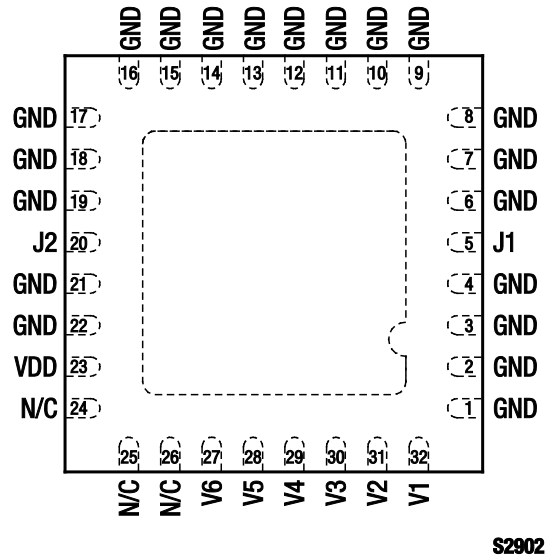

Figure 2. SKY12353-470LF Pinout – 32-Pin QFN (Top View)

Table 1. SKY12353-470LF Signal Descriptions

Pin #	Name	Description	Pin #	Name	Description
1	GND	Ground	17	GND	Ground
2	GND	Ground	18	GND	Ground
3	GND	Ground	19	GND	Ground
4	GND	Ground	20	J2	RF input/output
5	J1	RF input/output	21	GND	Ground
6	GND	Ground	22	GND	Ground
7	GND	Ground	23	VDD	Positive supply voltage input. Bypass this pin to ground using a 10 nF or larger capacitor.
8	GND	Ground	24	N/C	No connection
9	GND	Ground	25	N/C	No connection
10	GND	Ground	26	N/C	No connection
11	GND	Ground	27	V6	Control voltage input for 16 dB, MSB
12	GND	Ground	28	V5	Control voltage input for 8 dB
13	GND	Ground	29	V4	Control voltage input for 4 dB
14	GND	Ground	30	V3	Control voltage input for 2 dB
15	GND	Ground	31	V2	Control voltage input for 1 dB
16	GND	Ground	32	V1	Control voltage input for 0.5 dB

Functional Description

The SKY12353-470LF is composed of a silicon CMOS die and a GaAs digital attenuator die. The CMOS die contains a charge pump circuit that generates a negative voltage from the positive supply voltage (VDD). It decodes the six-bit control word applied to pins V1 through V6, and it drives the corresponding switching Field-Effect Transistors (FETs) on the GaAs attenuator die. This circuit is optimized to produce the lowest possible noise in the RF signal path.

The GaAs attenuator die is comprised of six resistive, fixed attenuator sections with nominal input and output impedance of 50 Ω. The attenuation of these sections is binary weighted and ranges from 0.5 dB, nominal, up to 16 dB nominal. These attenuator sections are either switched into or out of the main signal path between pins J1 and J2 according to the six-bit control word applied to pins V1 through V6.

The switching is performed by depletion mode pHEMT FETs on the attenuator die. The charge pump circuit on the CMOS die generates the negative voltage (nominally -4.4 V with $V_{DD} = 5$ V) required to enable reverse bias of the gate-source of the pHEMT FETs that must be switched to high drain-source impedance to properly select or bypass the fixed resistive attenuator sections.

Electrical and Mechanical Specifications

The absolute maximum ratings of the SKY12353-470LF are provided in Table 2. Electrical specifications are provided in Table 3.

Typical performance characteristics of the SKY12353-470LF are illustrated in Figures 3 through 6.

The state of the SKY12353-470LF is determined by the logic provided in Table 4.

Table 2. SKY12353-470LF Absolute Maximum Ratings

Parameter	Symbol	Minimum	Maximum	Units
Supply voltage	V_{DD}	3.3	6.0	V
RF input power: 50 MHz to 500 MHz >500 MHz	P_{IN}		0.5 2.0	W W
Supply current	I_{DD}		500	μA
Operating temperature	T_{OP}	-40	+85	°C
Storage temperature	T_{STG}	-65	+150	°C

Note: Exposure to maximum rating conditions for extended periods may reduce device reliability. There is no damage to device with only one parameter set at the limit and all other parameters set at or below their nominal value. Exceeding any of the limits listed here may result in permanent damage to the device.

CAUTION: Although this device is designed to be as robust as possible, Electrostatic Discharge (ESD) can damage this device. This device must be protected at all times from ESD. Static charges may easily produce potentials of several kilovolts on the human body or equipment, which can discharge without detection. Industry-standard ESD precautions should be used at all times.

Table 3. SKY12353-470LF Electrical Specifications (Note 1)
(V_{DD} = 5 V, T_{OP} = +25 °C, Characteristic Impedance [Z₀] = 50 Ω, , Unless Otherwise Noted)

Parameter	Symbol	Test Condition	Min	Typical	Max	Units
Insertion loss	IL	10 MHz to 500 MHz		1.2	1.5	dB
		500 MHz to 1 GHz		1.5	1.8	dB
Attenuation range				31.5		dB
Attenuation accuracy		Attenuation referred to insertion loss: 10 MHz to 500 MHz 500 MHz to 1 GHz	±(0.20 + 2% of attenuation setting) ±(0.25 + 3% of attenuation setting)			dB dB
RF I/O return loss	RL	Non-driven port terminated in Z ₀ , 10 MHz to 1 GHz	15	20		dB
Control voltage: Low High	V _{CTL}		0		0.8	V
			3.0		V _{DD}	V
Control current: Low High	I _{CTL}			20		μA
				20		μA
Switching characteristics: Rise/fall time On/off time Video feedthrough	t _r /t _f t _{ON} /t _{OFF}	10/90% or 90/10% of RF 50% V _{CTL} to 90/10% of RF t _r = 1 ns, bandwidth = 500 MHz		400		ns
				650		ns
				50		mV
1 dB Input Compression Point	IP1dB	50 MHz 500 MHz to 1 GHz		+22		dBm
				+29		dBm
3 rd Order Input Intercept Point	IIP3	2 input tones, +5 dBm each tone: 50 MHz 500 MHz to 1 GHz		+36		dBm
				+48		dBm
Supply voltage	V _{DD}		3.3	5.0	5.5	V
Supply current	I _{DD}			250		μA

Note 1: Performance is guaranteed only under the conditions listed in this Table.

Typical Performance Characteristics

($V_{DD} = 5\text{ V}$, $T_{OP} = +25\text{ }^{\circ}\text{C}$, Characteristic Impedance [Z_0] = $50\ \Omega$, , Unless Otherwise Noted)

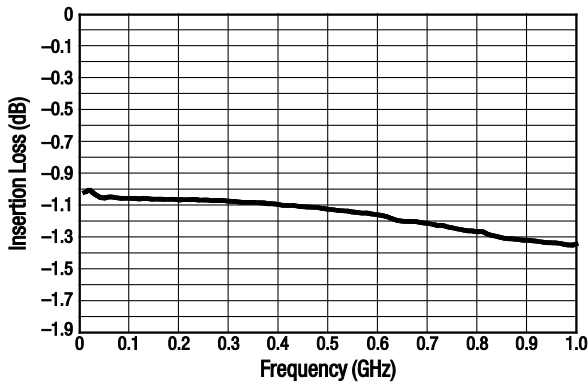

Figure 3. Insertion Loss vs Frequency

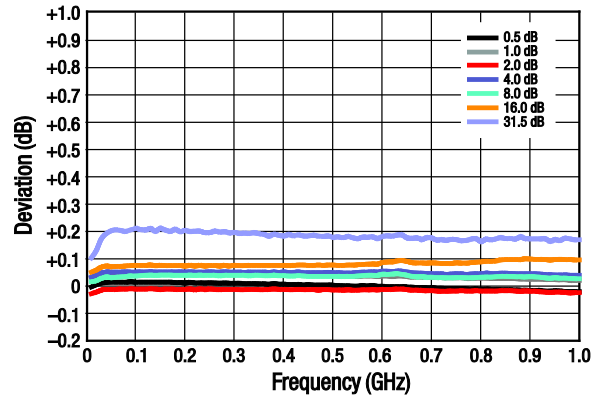

Figure 4. Attenuation Accuracy vs Frequency

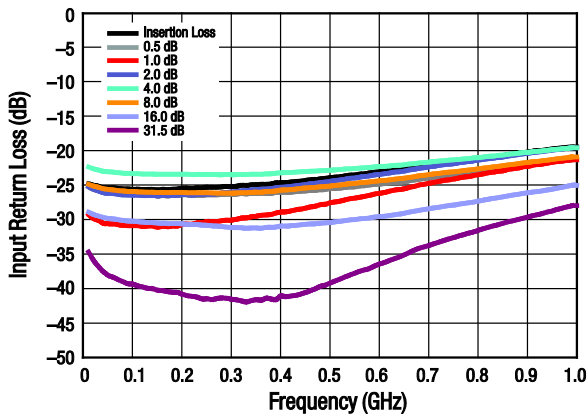

Figure 5. Input Return Loss vs Frequency

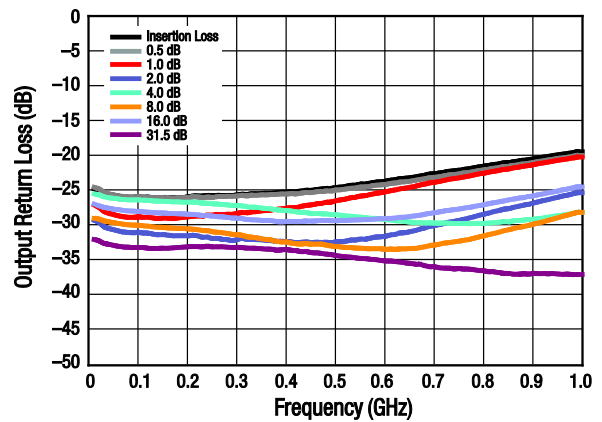

Figure 6. Output Return Loss vs Frequency

Table 4. SKY12353-470LF Truth Table

J1-J2 (Pins 5 & 20) Attenuation	V6 (Pin 27)	V5 (Pin 28)	V4 (Pin 29)	V3 (Pin 30)	V2 (Pin 31)	V1 (Pin 32)
Insertion loss	0	0	0	0	0	0
0.5 dB	0	0	0	0	0	1
1.0 dB	0	0	0	0	1	0
2.0 dB	0	0	0	1	0	0
4.0 dB	0	0	1	0	0	0
8.0 dB	0	1	0	0	0	0
16 dB	1	0	0	0	0	0
31.5 dB	1	1	1	1	1	1

Note: "1" = high control voltage: +3.0 V to V_{DD}.
 "0" = low control voltage: 0 to +0.8 V.

Evaluation Board Description

The SKY12353-470LF Evaluation Board is used to test the performance of the SKY12353-470LF digital attenuator. An Evaluation Board schematic diagram is shown in Figure 7. An assembly drawing for the Evaluation Board is shown in Figure 8.

Package Dimensions

The PCB layout footprint for the SKY12353-470LF is provided in Figure 9. Typical case markings are shown in Figure 10. Package dimensions for the 32-pin QFN are shown in Figure 11, and tape and reel dimensions are provided in Figure 12.

Package and Handling Information

Instructions on the shipping container label regarding exposure to moisture after the container seal is broken must be followed. Otherwise, problems related to moisture absorption may occur when the part is subjected to high temperature during solder assembly.

THE SKY12353-470LF is rated to Moisture Sensitivity Level 1 (MSL1) at 260 °C. It can be used for lead or lead-free soldering. For additional information, refer to the Skyworks Application Note, *Solder Reflow Information*, document number 200164.

Care must be taken when attaching this product, whether it is done manually or in a production solder reflow environment. Production quantities of this product are shipped in a standard tape and reel format.

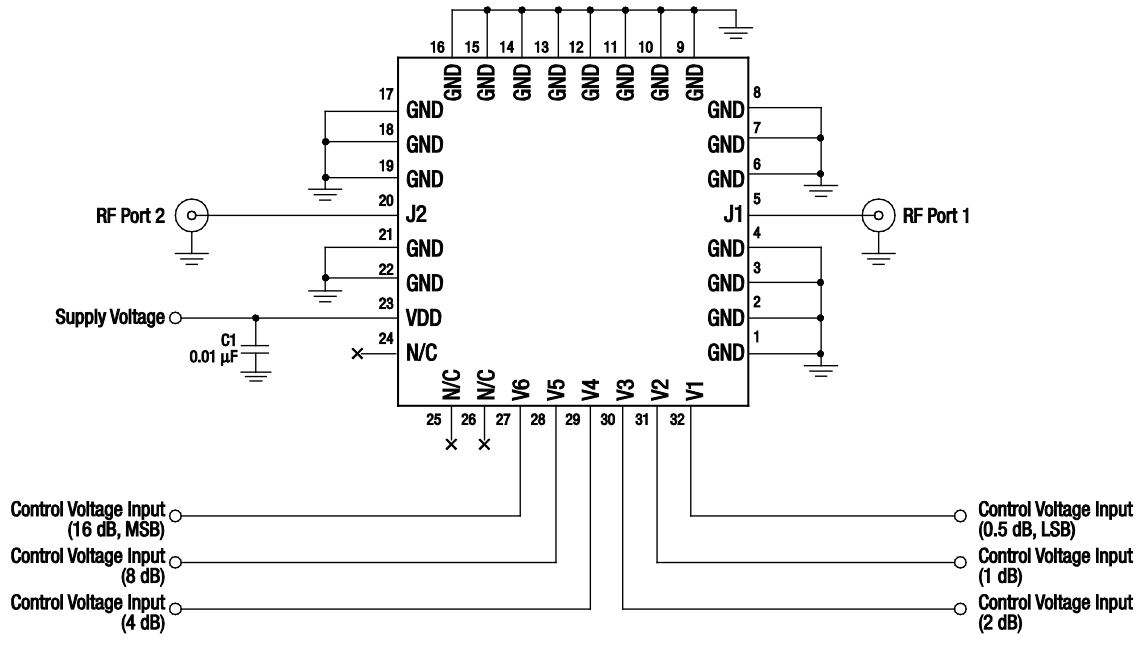

S2903

Figure 7. SKY12353-470LF Evaluation Board Schematic Diagram

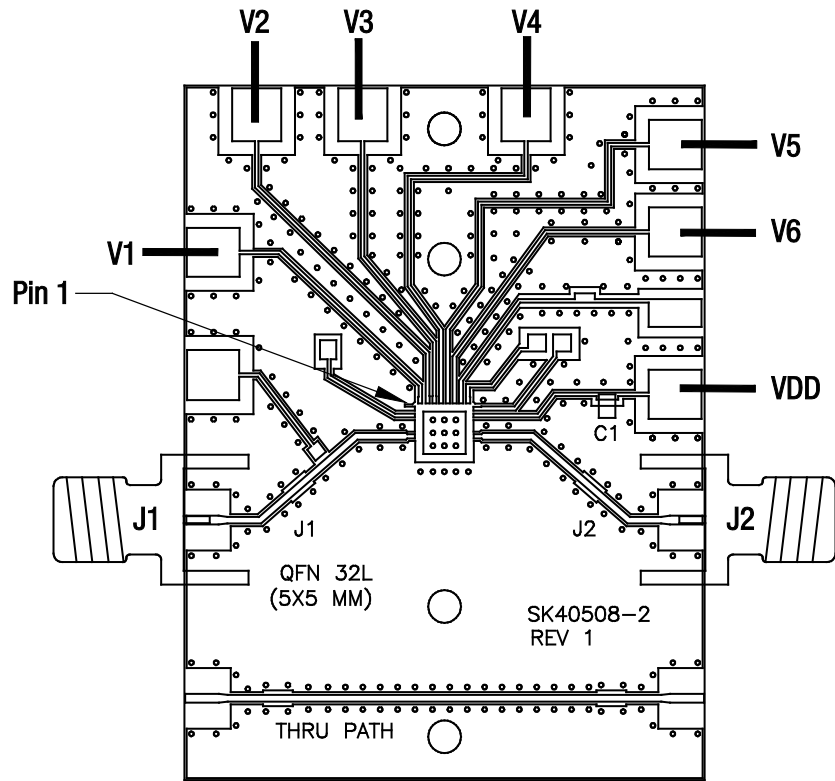

S2941

Figure 8. Evaluation Board Assembly Diagram

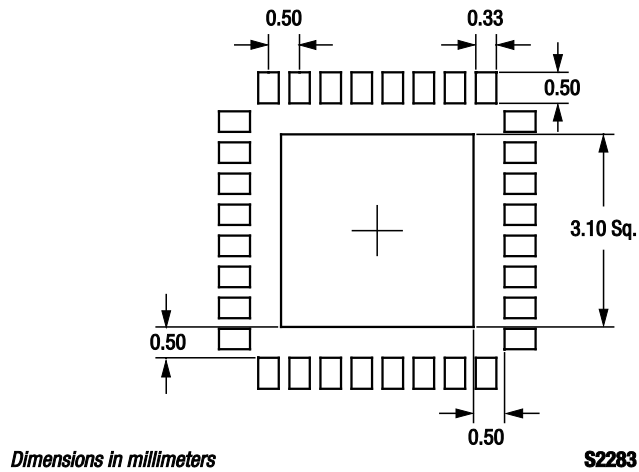

Figure 9. SKY12353-470LF PCB Layout Footprint (Top View)

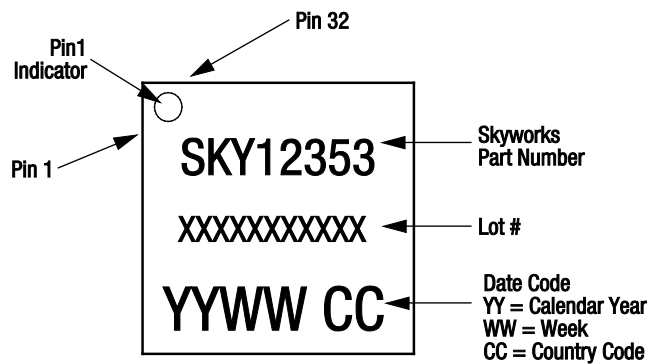
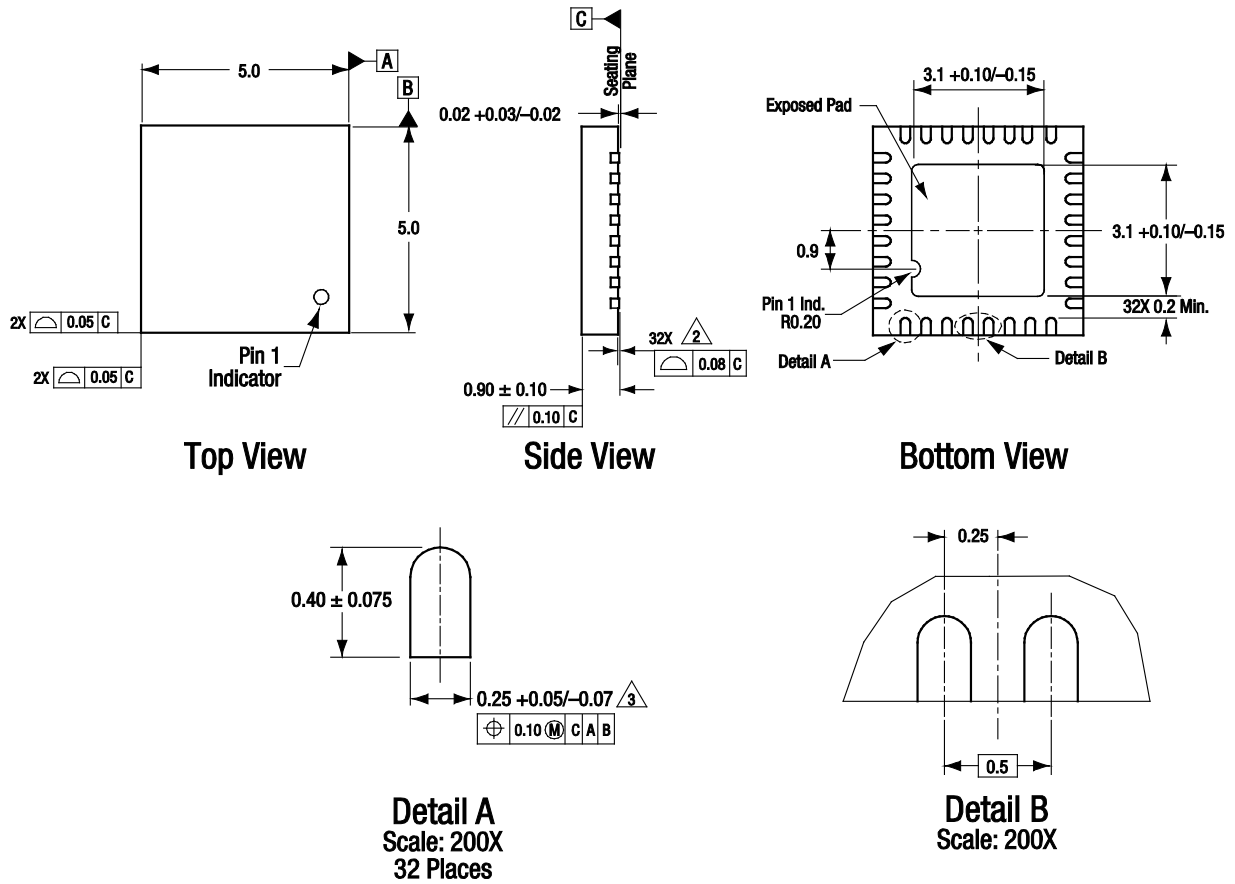

Figure 10. Typical Part Markings (Top View)



All measurements are in millimeters.

Dimensioning and tolerancing according to ASME Y14.5M-1994.

Coplanarity applies to the exposed heat sink slug as well as the terminals.

Dimension applies to metallized terminals and is measured between 0.15 mm and 0.30 mm from terminal tip. If the terminal has the optional radius on the other end of the terminal, the dimension should not be measured in that radius area.

Plating requirement per source control drawing (SCD) 2504.

S2369

Figure 11. SKY12353-470LF 32-Pin QFN Package Dimensions

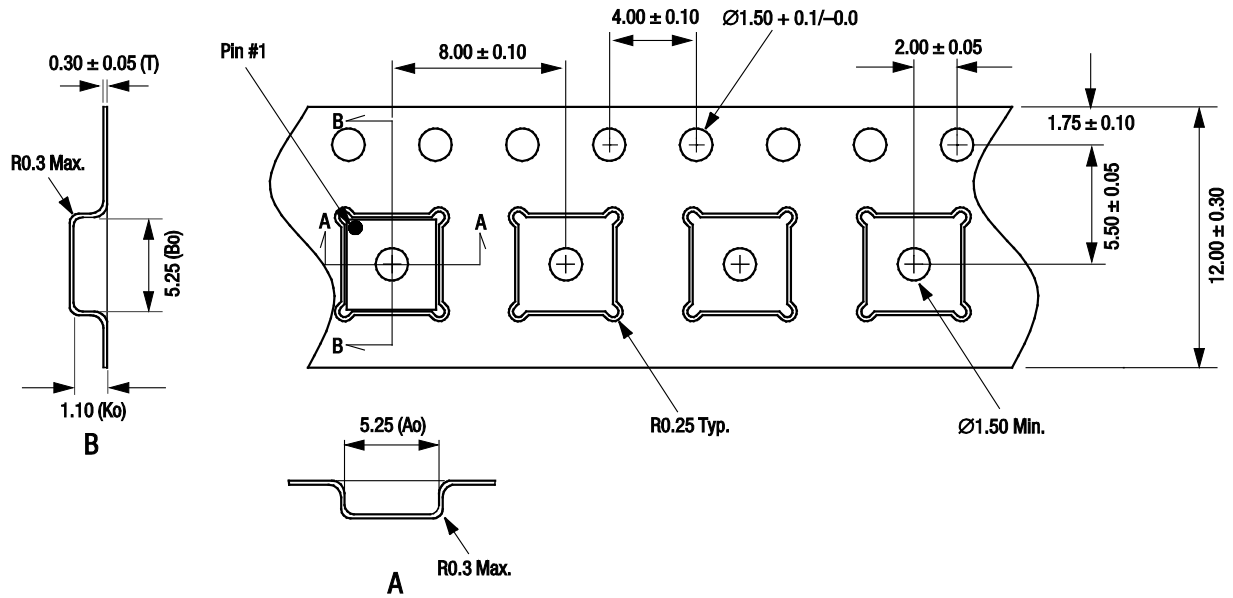

- Notes:**
1. Carrier tape: black conductive polystyrene, non-bakeable material.
 2. Cover tape material: transparent conductive HSA.
 3. Cover tape size: 9.20 mm width.
 4. ESD-surface resistivity is $\geq 1 \times 10^5 \sim < 1 \times 10^{10}$ Ohms/square per EIA, JEDEC TNR Specification.
 5. All measurements are in millimeters.

S1602

Figure 12. SKY12353-470LF Tape and Reel Dimensions

Ordering Information

Model Name	Manufacturing Part Number	Evaluation Board Part Numbers
SKY12353-470LF 10 MHz to 10 MHz, 6-Bit Digital Attenuator	SKY12353-470LF	SKY12353-470LF-EVB

Copyright © 2012 Skyworks Solutions, Inc. All Rights Reserved.

Information in this document is provided in connection with Skyworks Solutions, Inc. ("Skyworks") products or services. These materials, including the information contained herein, are provided by Skyworks as a service to its customers and may be used for informational purposes only by the customer. Skyworks assumes no responsibility for errors or omissions in these materials or the information contained herein. Skyworks may change its documentation, products, services, specifications or product descriptions at any time, without notice. Skyworks makes no commitment to update the materials or information and shall have no responsibility whatsoever for conflicts, incompatibilities, or other difficulties arising from any future changes.

No license, whether express, implied, by estoppel or otherwise, is granted to any intellectual property rights by this document. Skyworks assumes no liability for any materials, products or information provided hereunder, including the sale, distribution, reproduction or use of Skyworks products, information or materials, except as may be provided in Skyworks Terms and Conditions of Sale.

THE MATERIALS, PRODUCTS AND INFORMATION ARE PROVIDED "AS IS" WITHOUT WARRANTY OF ANY KIND, WHETHER EXPRESS, IMPLIED, STATUTORY, OR OTHERWISE, INCLUDING FITNESS FOR A PARTICULAR PURPOSE OR USE, MERCHANTABILITY, PERFORMANCE, QUALITY OR NON-INFRINGEMENT OF ANY INTELLECTUAL PROPERTY RIGHT; ALL SUCH WARRANTIES ARE HEREBY EXPRESSLY DISCLAIMED. SKYWORKS DOES NOT WARRANT THE ACCURACY OR COMPLETENESS OF THE INFORMATION, TEXT, GRAPHICS OR OTHER ITEMS CONTAINED WITHIN THESE MATERIALS. SKYWORKS SHALL NOT BE LIABLE FOR ANY DAMAGES, INCLUDING BUT NOT LIMITED TO ANY SPECIAL, INDIRECT, INCIDENTAL, STATUTORY, OR CONSEQUENTIAL DAMAGES, INCLUDING WITHOUT LIMITATION, LOST REVENUES OR LOST PROFITS THAT MAY RESULT FROM THE USE OF THE MATERIALS OR INFORMATION, WHETHER OR NOT THE RECIPIENT OF MATERIALS HAS BEEN ADVISED OF THE POSSIBILITY OF SUCH DAMAGE.

Skyworks products are not intended for use in medical, lifesaving or life-sustaining applications, or other equipment in which the failure of the Skyworks products could lead to personal injury, death, physical or environmental damage. Skyworks customers using or selling Skyworks products for use in such applications do so at their own risk and agree to fully indemnify Skyworks for any damages resulting from such improper use or sale.

Customers are responsible for their products and applications using Skyworks products, which may deviate from published specifications as a result of design defects, errors, or operation of products outside of published parameters or design specifications. Customers should include design and operating safeguards to minimize these and other risks. Skyworks assumes no liability for applications assistance, customer product design, or damage to any equipment resulting from the use of Skyworks products outside of stated published specifications or parameters.

Skyworks, the Skyworks symbol, and "Breakthrough Simplicity" are trademarks or registered trademarks of Skyworks Solutions, Inc., in the United States and other countries. Third-party brands and names are for identification purposes only, and are the property of their respective owners. Additional information, including relevant terms and conditions, posted at www.skyworksinc.com, are incorporated by reference.



Компания «ЭлектроПласт» предлагает заключение долгосрочных отношений при поставках импортных электронных компонентов на взаимовыгодных условиях!

Наши преимущества:

- Оперативные поставки широкого спектра электронных компонентов отечественного и импортного производства напрямую от производителей и с крупнейших мировых складов;
- Поставка более 17-ти миллионов наименований электронных компонентов;
- Поставка сложных, дефицитных, либо снятых с производства позиций;
- Оперативные сроки поставки под заказ (от 5 рабочих дней);
- Экспресс доставка в любую точку России;
- Техническая поддержка проекта, помощь в подборе аналогов, поставка прототипов;
- Система менеджмента качества сертифицирована по Международному стандарту ISO 9001;
- Лицензия ФСБ на осуществление работ с использованием сведений, составляющих государственную тайну;
- Поставка специализированных компонентов (Xilinx, Altera, Analog Devices, Intersil, Interpoint, Microsemi, Aeroflex, Peregrine, Syfer, Eurofarad, Texas Instrument, Miteq, Cobham, E2V, MA-COM, Hittite, Mini-Circuits, General Dynamics и др.);

Помимо этого, одним из направлений компании «ЭлектроПласт» является направление «Источники питания». Мы предлагаем Вам помощь Конструкторского отдела:

- Подбор оптимального решения, техническое обоснование при выборе компонента;
- Подбор аналогов;
- Консультации по применению компонента;
- Поставка образцов и прототипов;
- Техническая поддержка проекта;
- Защита от снятия компонента с производства.



Как с нами связаться

Телефон: 8 (812) 309 58 32 (многоканальный)

Факс: 8 (812) 320-02-42

Электронная почта: org@eplast1.ru

Адрес: 198099, г. Санкт-Петербург, ул. Калинина, дом 2, корпус 4, литера А.