



**S6J3310 Series**  
**S6J3320 Series**  
**S6J3330 Series**  
**S6J3340 Series**

## 32-bit Microcontroller Traveo™ Family

The Traveo family expands the company's automotive applications, scalability and high performance into one line-up and at the same time adds new features to fulfill the latest requirements of the automotive industry. Based on the powerful Arm® Cortex®- R5F core in single operations, it offers state-of-the-art real time performance, safety and security features. The family supports the latest in-car networks and offers high performance graphics engines optimized for a minimum memory footprint and embeds dedicated features to increase data security in the car.

S6J3310/20/30/40 is a microcontroller series for instrument clusters with small thin-film transistor (TFT) displays.

### Features

#### ■ System

- 32-bit Arm Cortex-R5F CPU core at up to 240 MHz
- General purpose I/O port: up to 148
- 12-bit A/D converter: up to 48 channels
- External interrupt: up to 24 channels
- Base timer: up to 32 channels
- 32-bit reload timer: up to 6 channels
- 32-bit free-run timer: 8 channels
- Input capture unit: 12 channels
- Output compare unit: 12 channels
- Stepper motor controller (SMC): 6 Units
- Built-in CR oscillator
- Real-time clock
- DMA controller: 16 channels
- JTAG debug interface

#### ■ Graphics and Display (optional)

- 2D graphic engine
- RGB888
- LCD : up to 4 COM x 32 SEG

#### ■ Communication

- CAN-FD: up to 6 channels
- Multi-function serial interface: up to 12 channels, selectable protocol: UART, CSIO, LIN and I<sup>2</sup>C
- Ethernet AVB MAC (optional)
- MediaLB (optional)
- Automotive Remote Handler for APIX® (optional)

#### ■ Memory

- HyperBus™ Memory interface
- DDR High Speed SPI
- External BUS interface

#### ■ Multimedia (optional)

- I2S input/output: 2 channels
- PCM to PWM output unit
- Sound mixer: 1 unit x 10 inputs
- Stereo audio DAC

#### ■ Security and Safety

- Secure Hardware Extension – SHE
- Safety features, such as MPU, TPU, ECC and others
- CRC generator: 1 channel
- Watchdog timer with window function
- Low voltage detector
- Clock supervisor for all source clocks

### Applications

#### ■ Instrument cluster

**Table of Contents**

<b>1. Overview</b> .....	<b>3</b>	6.2 Remark .....	58
1.1 Overview .....	3	<b>7. Port Configuration</b> .....	<b>59</b>
1.2 Document Definition .....	3	7.1 Resource Input Configuration Module .....	59
<b>2. Function List</b> .....	<b>4</b>	7.2 Port Output Function Configuration .....	148
2.1 Function List .....	4	<b>8. Precautions and Handling Devices</b> .....	<b>158</b>
2.2 Optional Function .....	6	8.1 Handling Precautions.....	158
<b>3. Product Description</b> .....	<b>9</b>	8.2 Handling Devices.....	161
3.1 Overview .....	9	<b>9. Electric Characteristics</b> .....	<b>163</b>
3.2 Product Description .....	9	9.1 Electrical Characteristics.....	163
<b>4. Package and Pin Assignment</b> .....	<b>15</b>	<b>10. Acronyms</b> .....	<b>261</b>
4.1 Pin Assignment .....	15	<b>11. Ordering Information</b> .....	<b>262</b>
4.2 Package Dimensions.....	27	<b>12. Errata</b> .....	<b>263</b>
<b>5. IO Circuit Type</b> .....	<b>31</b>	<b>13. Appendix</b> .....	<b>265</b>
5.1 I/O Circuit Type .....	31	13.1 Application 1: JTAG Tool Connection .....	265
5.2 Note.....	36	<b>14. Major Changes</b> .....	<b>266</b>
<b>6. Port Description</b> .....	<b>37</b>	<b>Document History</b> .....	<b>323</b>
6.1 Port Description List .....	37	<b>Sales, Solutions, and Legal Information</b> .....	<b>325</b>

## 1. Overview

### 1.1 Overview

S6J3310/20/30/40 is a microcontroller series which is to be applied to automotive systems representative of a graphical cluster control unit on a dashboard.

### 1.2 Document Definition

The related documents of S6J3310/20/30/40 are the followings.

**Table 1-1: Document Definition**

Document Type	Definition	Primary User	Document Code
S6J3310/20/30/40 Datasheet	This document. The function and its characteristics are specified quantitatively.	Investigator and hardware engineer	002-10635
S6J3300 Hardware Manual	S6J3300 Series 32-bit Microcontroller Traveo™ Family Hardware Manual The function and its operation of S6J3300 series are described.	Software engineer	002-10185
Traveo™ Platform Hardware Manual	32-Bit Microcontroller Traveo™ Family S6J33xx, S6J34xx, S6J35xx Series Hardware Manual Platform Part The function and its operation of CPU core platform are described.	Software engineer	002-07884
Application Note	The reference software, sample application, the reference board design and so on are explained.	Software and hardware engineer	002-03898 002-04455 002-04446 002-09716 002-04452 002-04096 002-12061 002-02495

**Notes:**

- Refer all documents for the system development.
- "Primary user" is a most likely engineer for whom the document is the most useful.
- The description of the datasheet and the S6J3300 Hardware Manual should precede the duplicated description of Traveo™ Platform Hardware Manual.
- Traveo™ Platform Hardware Manual is expected to be used as dictionary of platform specification.

## 2. Function List

### 2.1 Function List

The table shows the functions which are implemented in S6J3310/20/30/40 series.

**Table 2-1: Function List**

Function	S6J3310	S6J3320	S6J3330	S6J3340	Remarks
CPU core	Arm Cortex R5F				
FPU	Available				
PPU	Available				
MPU	Available				
TPU	Available				
Endian	Little endian				
Core clock frequency	240 MHz				
HPM bus frequency	200 MHz				
LLPM bus frequency	240 MHz				
Resource clock frequency	80 MHz (Max)				
Embedded CR oscillation	Slow clock: 100 kHz, Fast clock: 4 MHz (Center frequency)				See 9.1.4.1
PLL	PLL0, 1, 2, 3				
SSCG PLL	SSCG0, 1, 2, 3				
Clock supervisor	Available				
DMA	16 ch				
Boot-ROM	16 Kbyte				
JTAG	Available				
Data cache	16 Kbyte				
Instruction cache	16 Kbyte				
Program FLASH	Option				See 2.2.1
Work FLASH	112 Kbyte				
TCRAM	128 Kbyte				
System SRAM	384 Kbyte				
Backup RAM	32 Kbyte				
Security (SHE)	Option				
Low latency interrupt	Available				
Power domain	5 domains				
External power supply	5 V (VCC5, VCC53), 3 V (VCC3, VCC53), 1.2 V (VCC12)				
Embedded LDO power supply for 5.0 V	Available				
Low voltage detection of external power supply	Available				
Low voltage detection of internal LDO output	Available				
Hardware watchdog timer	Available				
Software watchdog timer	Available				
Package	Option				See 2.2.1
AUTOSAR	AUTOSAR 4.0.3				
General Purpose I/O	Option				See 2.2.3
Up/down counter	2 ch				
I/O timer	(FRT 5 ch x ICU 6 ch x OCU 6 ch) + (FRT 3 ch x ICU 6 ch x OCU 6 ch)				
32bit Reload timer	6 ch				
Real time clock	Available				Automatic calibration
Sound generator	5 ch				
Sound waveform generator	1 unit x 5 outputs		No		See 2.2.1
Sound mixer	1 unit x 10 inputs		No		See 2.2.1

Function	S6J3310	S6J3320	S6J3330	S6J3340	Remarks
Stereo audio DAC	1 unit (L and R)			No	See 2.2.1
PCM-PWM	1 unit (L and R)			No	See 2.2.1
Base timer	16 units (32 ch)				
Stepping motor controller (SMC)	For 6 gauges				
12bit-A/D converter	2 unit - 48 input ports (Max)				See 2.2.3
CRC	4 units				
Programmable CRC	1 unit				
Source clock timer	4 ch				
NMI	Available				
External interrupt	24 ch				
Internal interrupt	512 vectors				
I2S	2 ch		1 ch		One only supports an output as a function of the sound system.
DDR HSSPI	1 ch				A type of Quad SPI
Hyper BUS	1 ch				See the AC specification on 9.1.4.17.
Multi-function serial interface	12 ch				
CAN-FD	6 ch				
CAN-FD RAM (ECC supported)	16 KB/ch It equivalents to 128 message buffer per channel of MCAN module				
Ethernet AVB	1 unit			No	See 2.2.1
Media-LB (MOST50)	1 unit			No	See 2.2.1
LCD controller	4 COM x 32 SEG (Max)				See 2.2.3
Indicator PWM	1 ch				
MPU for AHB	1 unit				
MPU for AXI	1 unit				
Graphic engine clock	80 MHz (Max)				
Graphic AXI clock	80 MHz (Max)				
Display clock	25 MHz				
Display clock source	Graphic display controller clock or external clock				
Target resolution	WQVGA 480 x 272				
Target frame rate	60 fps				
Number of display outputs	1 output				
TTL output (RGB888)	Option				See 2.2.1
2D Graphic engine	1 unit				
2D Driver API	CYPRESS proprietary				
External BUS	1 ch				
APIX® for ARH (Automotive Remote Handler)	1 unit (2 ch)		No		See 2.2.1

**Notes:**

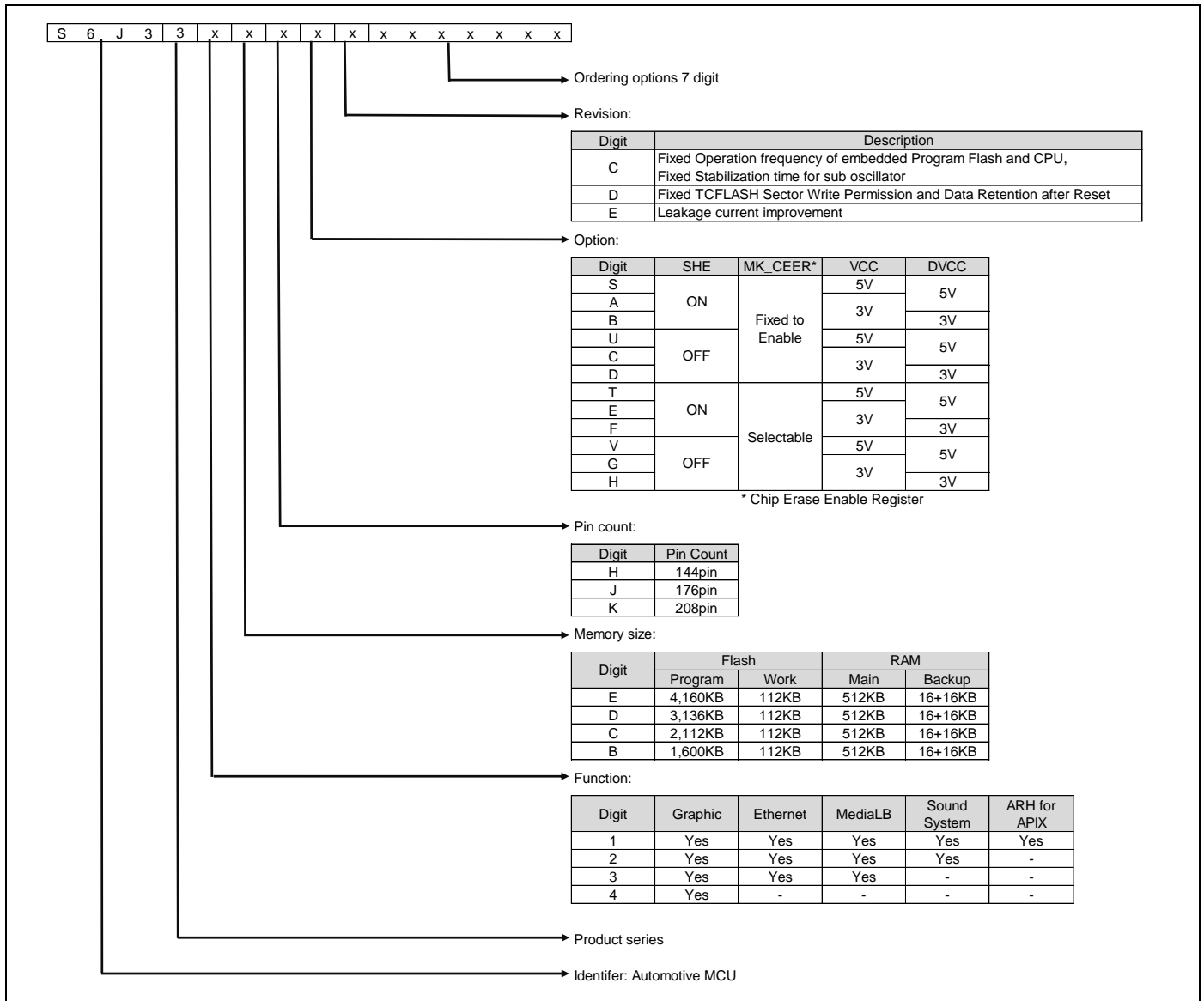
- The options are described in 2.2.

## 2.2 Optional Function

### 2.2.1 Basic Option

The figure shows the optional function and the part number relations of the series.

**Figure 2-1: Option and Part Number for S6J3310/20/30/40 Series**



**Notes:**

- This table only shows the relations between the optional function and the part numbers. That is, all products are not necessarily available for orders. See 11, and confirm actual availabilities of products.
- The sound system is composed of the sound waveform generator, the sound mixer, the audio DAC, PCM-PWM, and I2S0.

**2.2.2 ID**

ID is specified for each function digit and revision which is defined at [Figure 2-1](#).

Function Digit	Revision	Chip ID	JTAG ID
S,U,T,V	C	0x10122100	0x1000B5CF
	D, E	0x10122200	
A,C,E,G	C	0x10128100	
	D, E	0x10128200	
B,D,F,H	C	0x10120100	
	D, E	0x10120200	

**2.2.3 Restriction**

Some functions have restrictions which depend on package pin counts.

**Table 2-2: Pin Restriction**

Function	TEQFP176	TEQFP144
Analog input port (12bit-ADC)	-	AN4~7, AN10~11, AN14~15, AN25~26, AN28~30,
SEG port of LCD controller	-	SEG0~3 SEG5~8
General Purpose I/O	P4_00 ~ P4_31	P4_00 ~ P4_31 P3_00 ~ P3_31
CAN	RX0_2, TX0_2 RX1_0, TX1_0 RX1_1, TX1_1 RX2_0, TX2_0 RX2_1, TX2_1 RX3_2, TX3_2	RX0_1, TX0_1 RX0_2, TX0_2 RX1_0, TX1_0 RX1_1, TX1_1 RX2_0, TX2_0 RX2_1, TX2_1 RX3_1, TX3_1 RX3_2, TX3_2 RX5_1, TX5_1 RX6_1, TX6_1
BaseTimer	-	PPG4/5/6/7/8/9_TOUT0_1 PPG4/5/6/7/8/9_TOUT2_1 PPG10/11/12/13/15_TOUT0_1 PPG10/11/12/13/14/15_TOUT2_1 PPG0/1/2/3/4/5_TIN1_1 PPG6/7/8/9/10/11_TIN1_1 PPG12/13/14/15_TIN1_1
ExtBus	-	MDQM1 MAD15~21 MDATA8~15

Function	TEQFP176	TEQFP144
External Interrupt	EINT1_4, EINT1_5 EINT2_1, EINT2_2 EINT3_2, EINT4_2 EINT5_4, EINT5_5 EINT6_4, EINT7_1 EINT7_4, EINT8_4 EINT8_5, EINT9_1 EINT10_1, EINT10_4 EINT10_5, EINT13_2 EINT13_3, EINT14_2 EINT14_3, EINT15_3 EINT16_1, EINT16_3 EINT16_4, EINT19_4 EINT20_3, EINT21_3 EINT22_1, EINT22_3 EINT23_3, EINT23_4	EINT0_4, EINT1_1 EINT1_4, EINT1_5 EINT2_1, EINT2_2 EINT2_4, EINT3_1 EINT3_2, EINT3_4 EINT4_2, EINT4_4 EINT5_4, EINT5_5 EINT6_1, EINT6_4 EINT7_1, EINT7_4 EINT8_1, EINT8_4 EINT8_5, EINT9_1 EINT9_2, EINT10_1 EINT10_2, EINT10_4 EINT10_5, EINT11_2 EINT11_5, EINT12_1 EINT12_2, EINT12_5 EINT13_2, EINT13_3 EINT13_5, EINT14_1 EINT14_2, EINT14_3 EINT14_5, EINT15_2 EINT15_3, EINT16_1 EINT16_2, EINT16_3 EINT16_4, EINT16_5 EINT17_1, EINT17_3 EINT17_5, EINT18_1 EINT18_3, EINT18_5 EINT19_1, EINT19_3 EINT19_4, EINT20_1 EINT20_2, EINT20_3 EINT21_1, EINT21_3 EINT22_1, EINT22_3 EINT23_3, EINT23_4

**Notes:**

- See multiplexed functions on pin assignment sheet.
- The optional restriction will be added without notification.



### 3. Product Description

#### 3.1 Overview

This chapter explains the product features of S6J3310/20/30/40 series. The description of this chapter should precede the duplicated description on *Traveo™ Platform Hardware Manual*.

#### 3.2 Product Description

The table shows features.

**Table 3-1: Product Features**

Feature	Description
Technology	40-nm CMOS technology with embedded FLASH Fully automotive qualified according to ISO/TS 16949 and AEC-Q100 Developed according to ISO26262, safety target ASIL-B
Functional Safety	The product series has some functional safety features suited for ASIL-B application.
Peripherals	See function list.
Power Domain (PD)	See the <i>Traveo™ Platform Hardware Manual</i> and chapter STATE TRANSITION in detail. The product series supports the power off control of PD1, PD2 (including PD3 and 5), PD4_0, PD4_1 and PD6. The power domain resets of PD3 and PD5 included in PD2 are not supported in the product series, and "0" is always read from the reset factor flags of them. This series doesn't support partial wakeup for PD6.
Debug and Trace	See the <i>Traveo™ Platform Hardware Manual</i> in detail. - Standard 5-pin JTAG interface - 4 kB Embedded Trace Buffer 4-bit trace support for TEQFP package.
System Control	See the <i>Traveo™ Platform Hardware Manual</i> in detail. Main and sub oscillator is available. - A wide range of 3.6 - 16MHz is available for main oscillator - 32KHz is available for sub oscillator Sub clock is enable/disable by register settings
Clock	See the <i>Traveo™ Platform Hardware Manual</i> in detail. CLK_CLKO (Clock Output Function) is supported. Main Oscillation Stabilization Wait Time (at 4 MHz):8.19ms (Initial value)
Embedded CR oscillation	See the <i>Traveo™ Platform Hardware Manual</i> in detail. Stabilization time is as followings. - 0.35 ms to 0.8 ms for 4 MHz (Fast clock) - 0.43 ms to 1.28 ms for 100 kHz (Slow clock)
Clock Supervisor	See the <i>Traveo™ Platform Hardware Manual</i> in detail. This product series doesn't support clock supervisor output port. (Related register and internal circuit is implemented.)
Reset	RSTX pin + MD pin simultaneous assert INITX (Same as INITX pin input) - Occurrence factor: Simultaneously inputting "L" level to RSTX pin and inputting "L" level to MD pin - Release factor: Inputting "H" level to RSTX pin See the <i>Traveo™ Platform Hardware Manual</i> in detail. Following resets are not mounted on this device. - SRSTX (and nSRST pin) The product series does not support EX5VRST and writing EX5VRSTCNT bits in SYSC0_SPECFGR has no effect.

Feature	Description
Hardware watchdog	See the <i>Traveo™ Platform Hardware Manual</i> in detail. Hardware watchdog function stops during PSS mode. In the related register of HWDG_CFG, the bit ALLOWSTOPCLK is always read as 1 (HWDG_CFG.ALLOWSTOPCLK = 1). The product series doesn't support Watchdog Counter Monitor Output port. (Related register and internal circuit is implemented.)
Standby mode	See the <i>Traveo™ Platform Hardware Manual</i> in detail. Standby mode with 5 V (or 3 V) single external power supply is available. Turning off the 1.2 V external power supply in standby mode is available. The long term pulse of the indicator PWM can be outputted during RTC Standby mode.
PLL / SSCG PLL	See the <i>Traveo™ Platform Hardware Manual</i> in detail. Use case assumption is following. PLL <ul style="list-style-type: none"> <li>- Sound system clock</li> <li>- Sound frequency master clock</li> <li>- Peripherals</li> <li>- Display clock</li> <li>- Trace clock</li> </ul> SSCG <ul style="list-style-type: none"> <li>- CPU core</li> <li>- GDC core</li> <li>- Hyper BUS</li> <li>- DDR-HSSPI</li> </ul> Product supports down spread and center spread modes with the conditions defined in <a href="#">9.1.4.3 Internal Clock Timing (S6J3310)</a> .
External Interrupts	See the <i>Traveo™ Platform Hardware Manual</i> in detail.
NMI	See the <i>Traveo™ Platform Hardware Manual</i> in detail. 1 NMI pin.
Memory Protection	MPU16 AHB: See the <i>Traveo™ Platform Hardware Manual</i> in detail. MPU for AXI: ch.0 MPU for AHB: ch.1 Additional MPU for Graphic sub system, MediaLB and Ethernet AVB. They are described on the chapter of MPU for AHB and MPU for AXI  To configure Lock or Unlock for both MPUXn_UNLOCK and MPUHn_UNLOCK, <ul style="list-style-type: none"> <li>- Lock: 0x112ABB56</li> <li>- Unlock: 0xACCABB56</li> </ul>
Peripheral Protection	See the <i>Traveo™ Platform Hardware Manual</i> in detail. Protected peripherals are described in the base address map.
Internal Memories System SRAM	384 KByte 1 wait cycle is necessary for RAM read at over 120MHz.
Internal Memories TCRAM	128 KByte
Internal Memories Backup RAM	32 KByte Backup RAM can only be operated in RUN mode (normal operation mode). In other mode the memory content should be retained, but it cannot be operated. SLEEP control for Backup RAM is not supported and cannot be used.

Feature	Description
Embedded Program/Work Flash Memory	<p>Embedded Program Flash can be accessed with 0-wait-cycle if CPU frequency is 80MHz or less.            0-wait-cycle: 80MHz or less.            1-wait-cycle: 160MHz or less.            2-wait-cycle: more than 160MHz.</p> <p>Work Flash can be accessed with 0-wait-cycle if CPU frequency is 12.5MHz or less.            6-wait-cycle: 80MHz or less.            12-wait-cycle: 160MHz or less.</p> <p>The wait-cycle setting see the <i>Traveo™ Platform Hardware Manual</i> in details.            The CLK_FCLK maximum frequency should be referred in <a href="#">9.1.4.3</a>.</p> <p>Erase suspend is supported. Reading and writing to the other sector are possible when Flash Erase is suspended.            Serial Flash programming and Parallel Flash programming are supported.            Margin mode is not supported.</p>
Internal Power Domain	<p>PD1: Always ON            PD2: Cortex R5F platform/ GDC/ additional peripherals            PD4: Backup RAM in Always On domain            PD6: Peripherals in Always On domain            * The chapter of the block diagram explains in detail.</p>
Power Supply	<p>5 V, and 3 V, 1.2 V external power supply is required.            Built in LDO provides internal power supply for Always On region (PD1).            1.2 V external power supply control pin is supported.            3 V external power supply could be controlled by GPIO.            There are constraints of power on/off sequence.</p>
Low Voltage Detection	<p>LVD for external voltage is supported.            LVD for internal voltage is supported.            See <a href="#">9.1.4.11</a> and <a href="#">9.1.4.12</a>.</p>
Low voltage detection for RAM retention (RVD)	<p>RVD for RAM retention is effective during the standby mode only. That is, it is only for the Backup RAM of 32KB that the function is available.</p>
Resource inter-connect	<p>The output signal of some resources can be inputted to the other resource.</p>
I/O Ports	<p>5 V general purpose I/O            3 V general purpose I/O            Multi input level and multi output drivability            Pull-up, pull-down function is available.            Resource input and output is multiplexed.            +B input is allowed many pins of 3.3 V, 5 V and 3.3 V/5 V I/O domain.</p>
A/D Converter	<p>12 bit resolution, 2 unit (Unit0 is possible to select channels 4-31. Unit1 is possible to select channels 32-63.)            48 channels of analog input for TEQFP208            48 channels of analog input for TEQFP176            35 channel of analog input for TEQFP144            24 channels of them are shared with the SMC for TEQFP208/176/144            External trigger and timer trigger are available.            The description of the A/D converter function should be referred in the <i>S6J3300 Hardware Manual</i>. Though the chapter of I/O port in <i>Traveo™ Platform Hardware Manual</i> describes another A/D converter function, do not refer it.            A/D Channel Control Register (ADC12Bn_CHCTRL0) [bit5:0] ANIN[5:0]: Analog Input Selection bits.            This register setting is possible of channel 0-31 (the register value is 00_0000 to 01_1111).            AN39 to AN63 are not support for S6J33xxxAx, S6J33xxxCx, S6J33xxxEx, and S6J33xxxGx option.</p>
CRC	<p>See the <i>Traveo™ Platform Hardware Manual</i> in detail.</p>

Feature	Description
Programmable CRC	DMA support
Sound Generator	Produces sound/melody with varying frequency and amplitude for convenient duration Square wave sound output Automatic linear amplitude increment or decrement Interrupt request generated when specified sound length has ended
Sound Waveform generator	Sine waveform, saw-tooth waveform and Square waveform are generated with easy configuration of the parameters which specified sound sources. Fade-in and Fade-out control for reverberation.
Sound Mixer	The input channels of 0 - 4 are reserved for waveform generator. Mixing different sampling frequency sounds. Mixing Internal sounds and External I2S input sounds. Saturating addition function for keeping sound quality. Cut a specific frequency data by digital filter. LPF is support by FIR filter. Fade-in and Fade-out control.
PCM-PWM	Conversion of PCM audio streaming to Pulse Width Modulated signals. Supports 2 output channels for stereo and mono data Up to 16-bit output sample resolution Support for half and full H-bridges
Audio DAC	The sound source of the fixed 48 kHz sampling frequency can be outputted. 1 unit, L/R channels support. BTL connection is available.
I2S	2 ch. - I2S0 only supports the output of sound sources. - I2S1 supports both the input and the output.
Base Timer	See the <i>Traveo™ Platform Hardware Manual</i> in detail.  A unit consists of a pair of 16-bit base timers. 16 units, that is, 32 channels of base timers are available.
Reload Timer	See the <i>Traveo™ Platform Hardware Manual</i> in detail.
I/O Timer	See the <i>Traveo™ Platform Hardware Manual</i> in detail.
Up/Down Counter	See the <i>Traveo™ Platform Hardware Manual</i> in detail.
Multi-Functional Serial (MFS)	See the <i>Traveo™ Platform Hardware Manual</i> in detail.  Only 2 ports of MFS have the dedicated I/O for I <sup>2</sup> C. See I <sup>2</sup> C timing in 9.1.4.6 Multi-Function Serial in detail. The I <sup>2</sup> C is not designed to be hot swappable. CTS/RTS is not mounted (hardware flow control is not supported for this series.)
CAN-FD	Flexible data rate is supported. 16 KB/ch of message RAM is available. The clock output from CAN pre-scaler is supplied to every CAN. ECC error generation function of the message RAM is not supported for this device. Therefore CAN FD ECC Error Insertion Control Register (FDFECCR) is not writeable.
Real Time Clock (RTC) with auto-calibration	See the <i>Traveo™ Platform Hardware Manual</i> in detail.
DDR High Speed SPI	ch.0: HSSPI as a MCU peripheral
Hyper BUS I/F	ch.0: Hyper Bus as a MCU peripheral The following register is not supported and cannot be used. - Controller Status Register (HYPERBUSIn_CSR) - Interrupt Enable Register (HYPERBUSIn_IEN) - Interrupt Status Register (HYPERBUSIn_ISR) - Write Protection Register (HYPERBUSIn_WPR) - Test Register (HYPERBUSIn_TEST)  GPO signal can only be used for "Internal Control example by GPO" in this product, that is, it can select using HyperBus of PF or using HyperBus of Graphic Sub System.

Feature	Description
Stepper Motor Control (SMC)	Each channel has 6 motor drivers with high output capability
External Interrupt Capture Unit (EICU)	See the <i>Traveo™ Platform Hardware Manual</i> in detail.
Ethernet AVB	10/100 Mbps MII-Interface Supports Audio-Video Bridging (AVB)
MediaLB	MOST50 (1024FS) 3 wires Maximum 15 ch is available.
LCD Controller	TEQFP208: 4 com x 32 seg TEQFP176: 4 com x 32 seg TEQFP144: 4 com x 24 seg LCDC pins are initialized with Reset. (Stop LCDC alternating current output) Duty and Static of segment output is supported. (SEG23/ST0, SEG24/ST1, SEG25/ST2, SEG26/ST3, SEG27/ST4, SEG28/ST5, SEG29/ST6, SEG30/ST7, SEG31/ST8)
SHE	See the <i>Traveo™ Platform Hardware Manual</i> in detail.
Source Clock Timer	See the <i>Traveo™ Platform Hardware Manual</i> in detail.
Graphics Subsystem	80 MHz maximum clock frequency Variable setting about GDC clock. (Asynchronous with CPU clock) 480 x 272 pixels maximum frame resolution Video modes up to 25 MHz pixel clock RGB888, Order replacement of RGB pins.
External BUS	TEQFP208: 22 bit address and 16 bit data TEQFP176: 22 bit address and 16 bit data TEQFP144: 15 bit address and 8 bit data
ARH	2 ch This device does not have PHY macro and its function.
Power Supply Control (PSC)	PSC (PSC_1) output is used for external 1.2 V power supply module control and automatically switched with the following condition. "High": Request to supply VCC12 - "Power ON Reset" is released - CPU wakes up from PSS shutdown mode "Low": Request to stop supplying VCC12 - CPU transfers from RUN mode to PSS shutdown mode.  For timing chart of output signals include PSC in detail, see the " <i>S6J3300 Hardware Manual</i> " and chapter "State Transition"

**3.2.1 Ethernet**

The following functions are not supported.

Functions	Remarks
External FIFO Interface	
Additional Low Latency TX FIFO Interface for DMA configurations	
MAC Transmit Block <ul style="list-style-type: none"> <li>- half-duplex</li> <li>- collision</li> <li>- back_pressure</li> </ul>	
MAC Filtering Block <ul style="list-style-type: none"> <li>- external address match</li> <li>- Wakeup On Lan</li> </ul>	
Energy Efficient Ethernet support	
LPI Operation in Cadence IP	
PHY Interface <ul style="list-style-type: none"> <li>- GMII</li> <li>- SGMII</li> <li>- TBI</li> </ul>	
10/100/1000 Operation <ul style="list-style-type: none"> <li>- 1000 M</li> </ul>	
SGMII Operation	
Jumbo Frames	
Physical Control Sub-Layer	

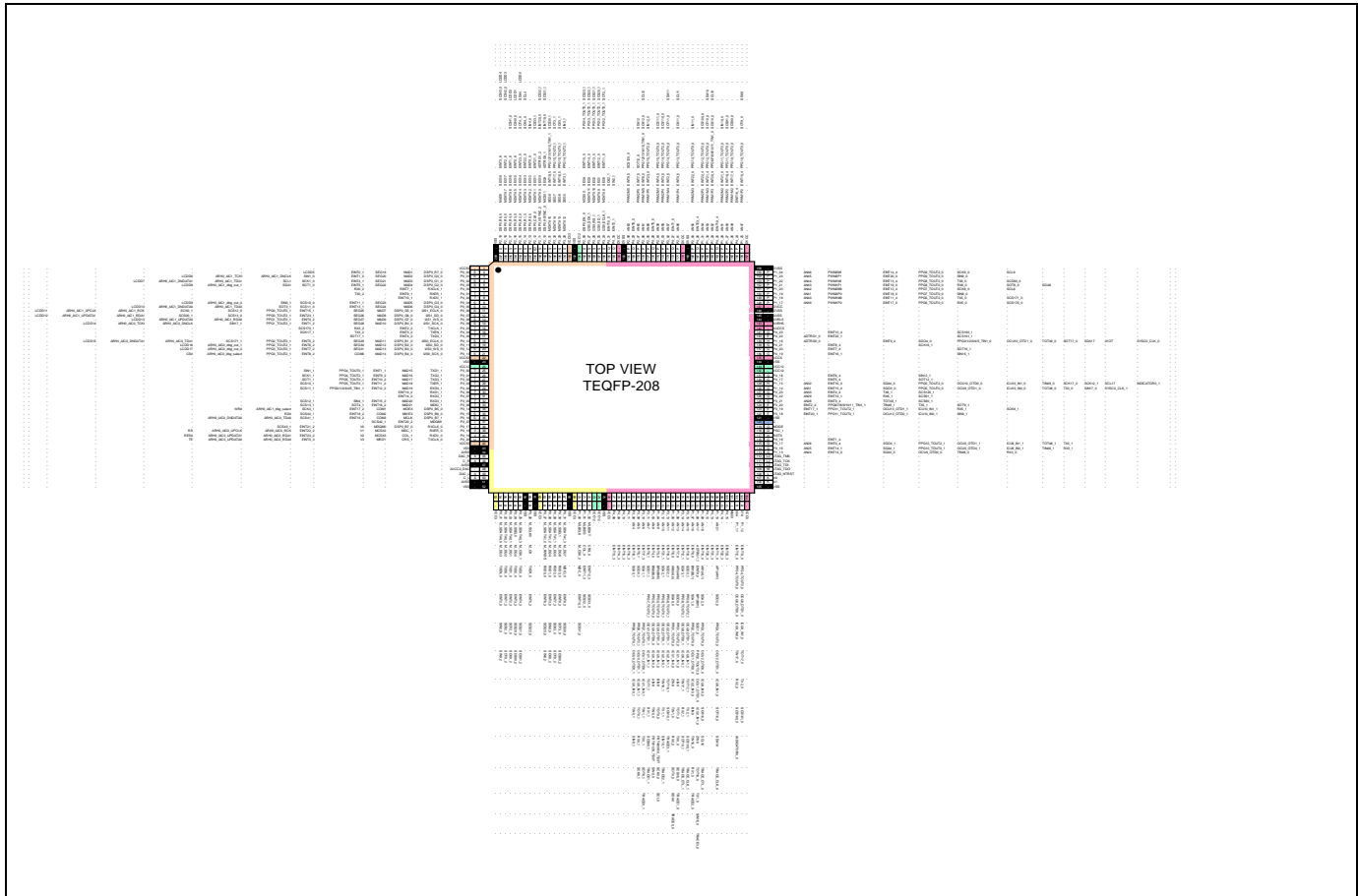
## 4. Package and Pin Assignment

### 4.1 Pin Assignment

Alphabets with pin numbers are signs specify I/O circuit type.

#### 4.1.1 TEQFP-208 Pin Assignment

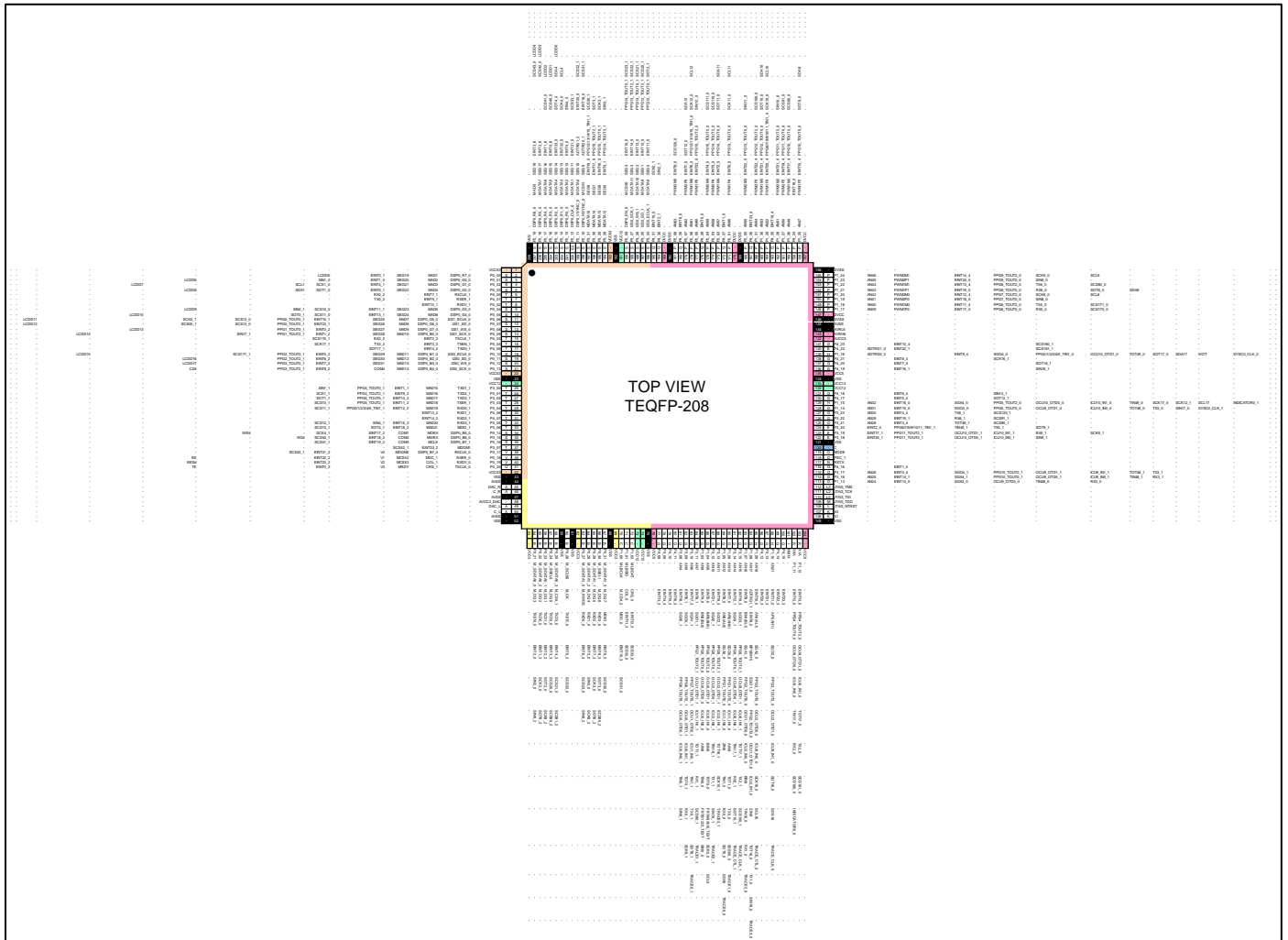
Figure 4-1: TEQFP-208 (S6J331xKyz \*1)



\*1: x, y, z are selected from the following parameters:

- x: E, D, C, B (Memory Size)
- y: S, A, B, U, C, D, T, E, F, V, G, H (Option)
- z: C, D, E (Revision)

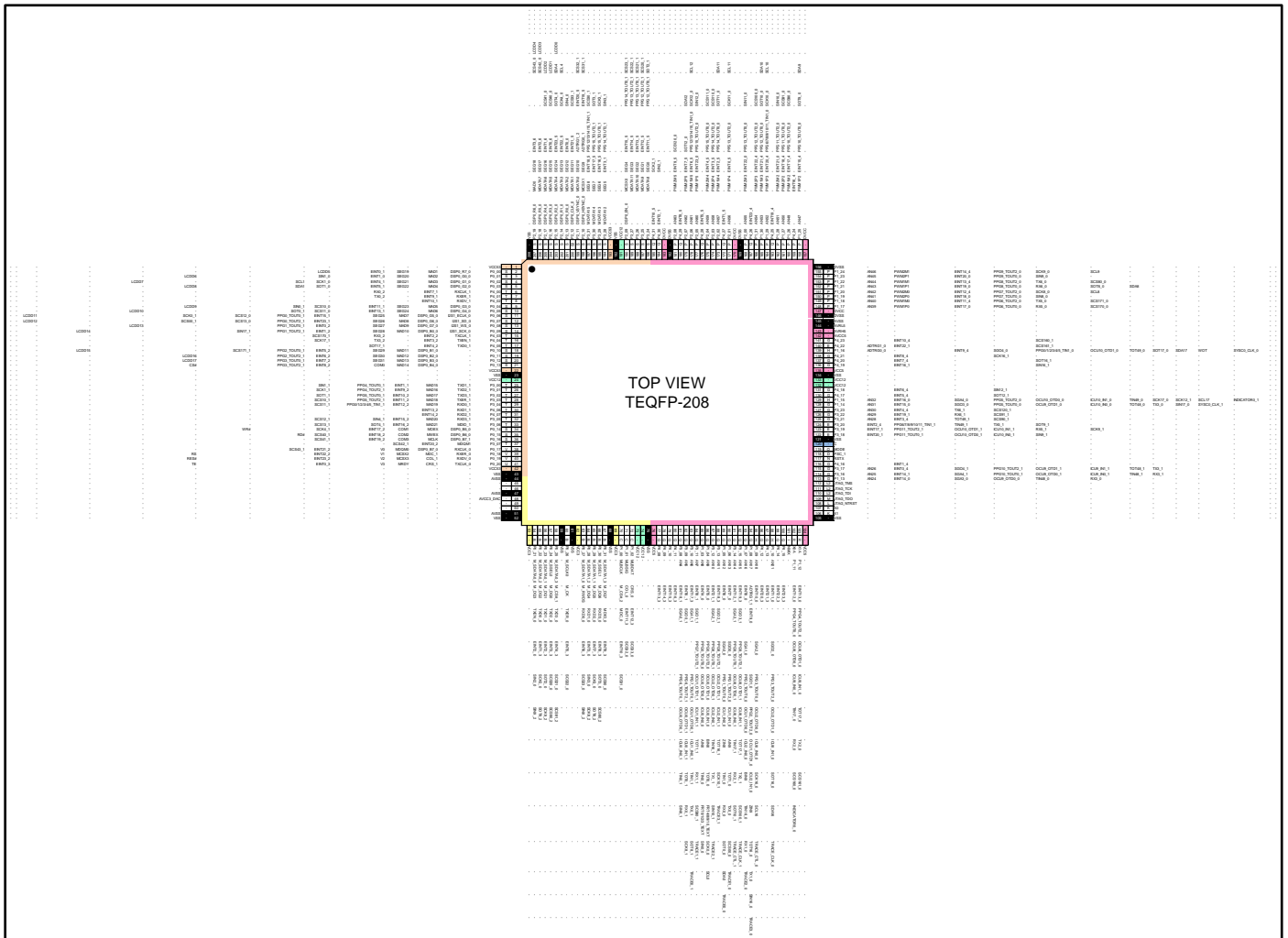
Figure 4-2: TEQFP-208 (S6J332xKyz \*1)



\*1: x, y, z are selected from the following parameters:  
 x: E, D, C, B (Memory Size)  
 y: S, A, B, U, C, D, T, E, F, V, G, H (Option)  
 z: C, D, E (Revision)

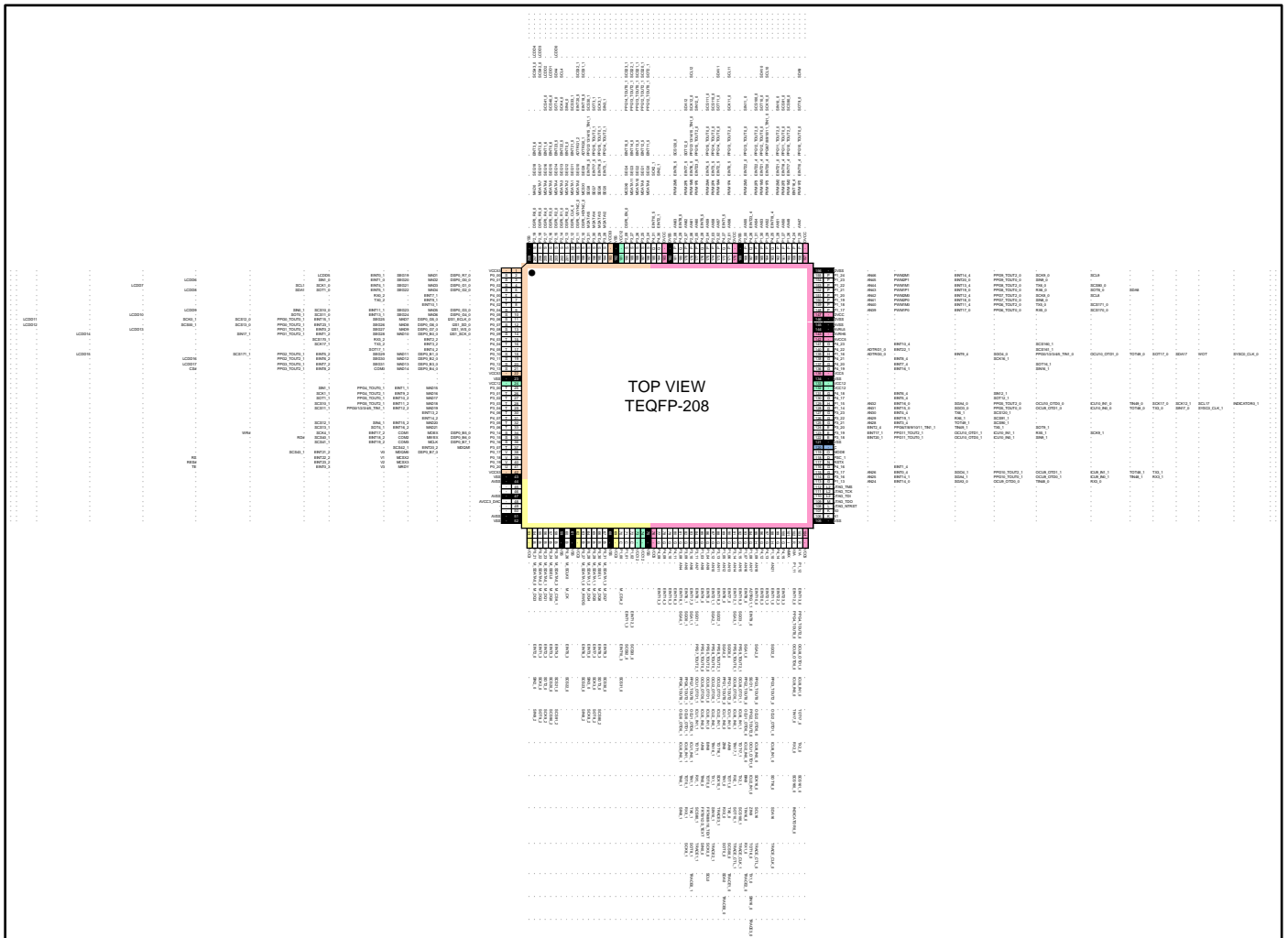


Figure 4-3: TEQFP-208 (S6J333xKyz \*1)



\*1: x, y, z are selected from the following parameters:  
 x: E, D, C, B (Memory Size)  
 y: S, A, B, U, C, D, T, E, F, V, G, H (Option)  
 z: C, D, E (Revision)

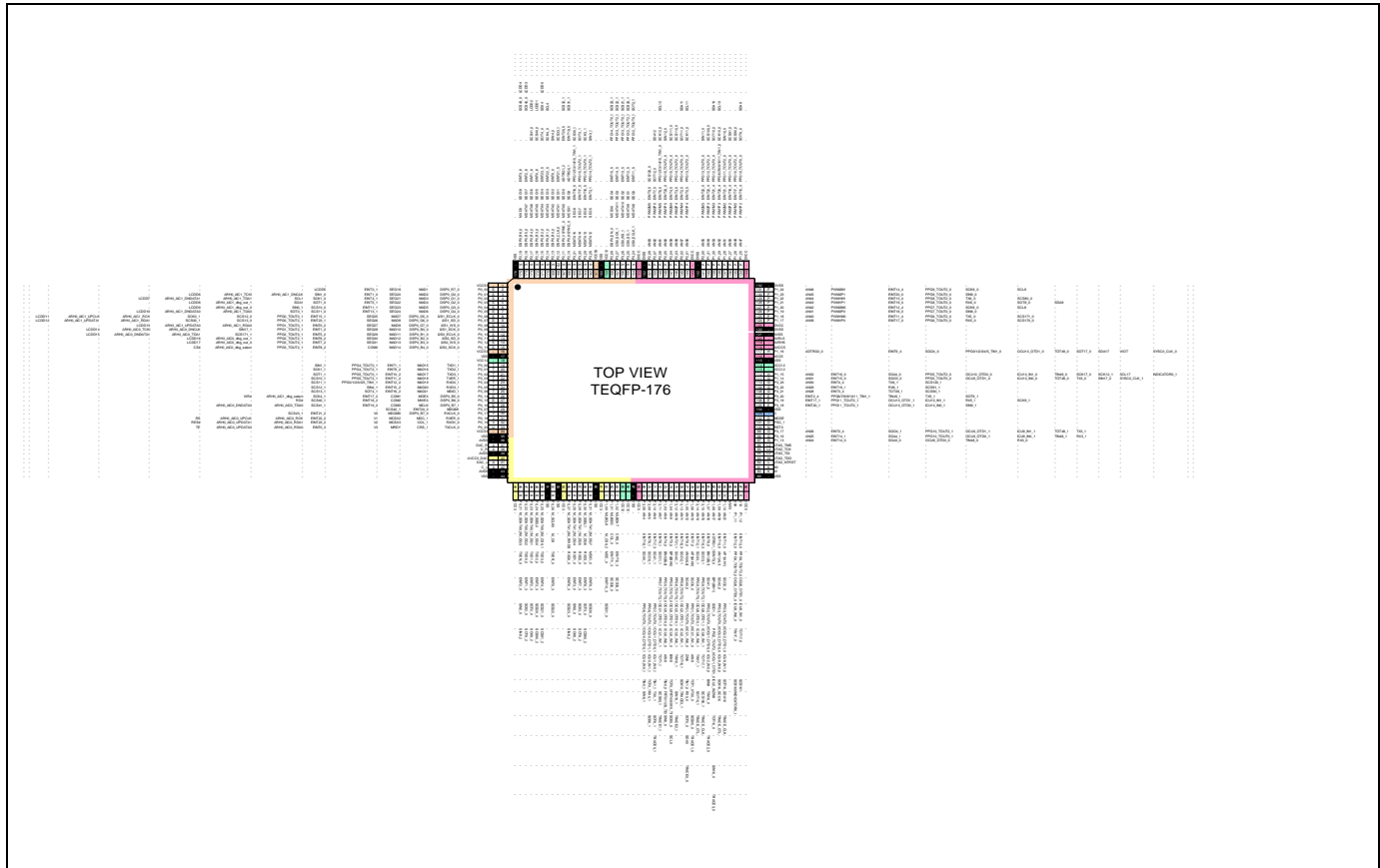
Figure 4-4: TEQFP-208 (S6J334xKyz \*1)



\*1: x, y, z are selected from the following parameters:  
 x: E, D, C, B (Memory Size)  
 y: S, A, B, U, C, D, T, E, F, V, G, H (Option)  
 z: C, D, E (Revision)

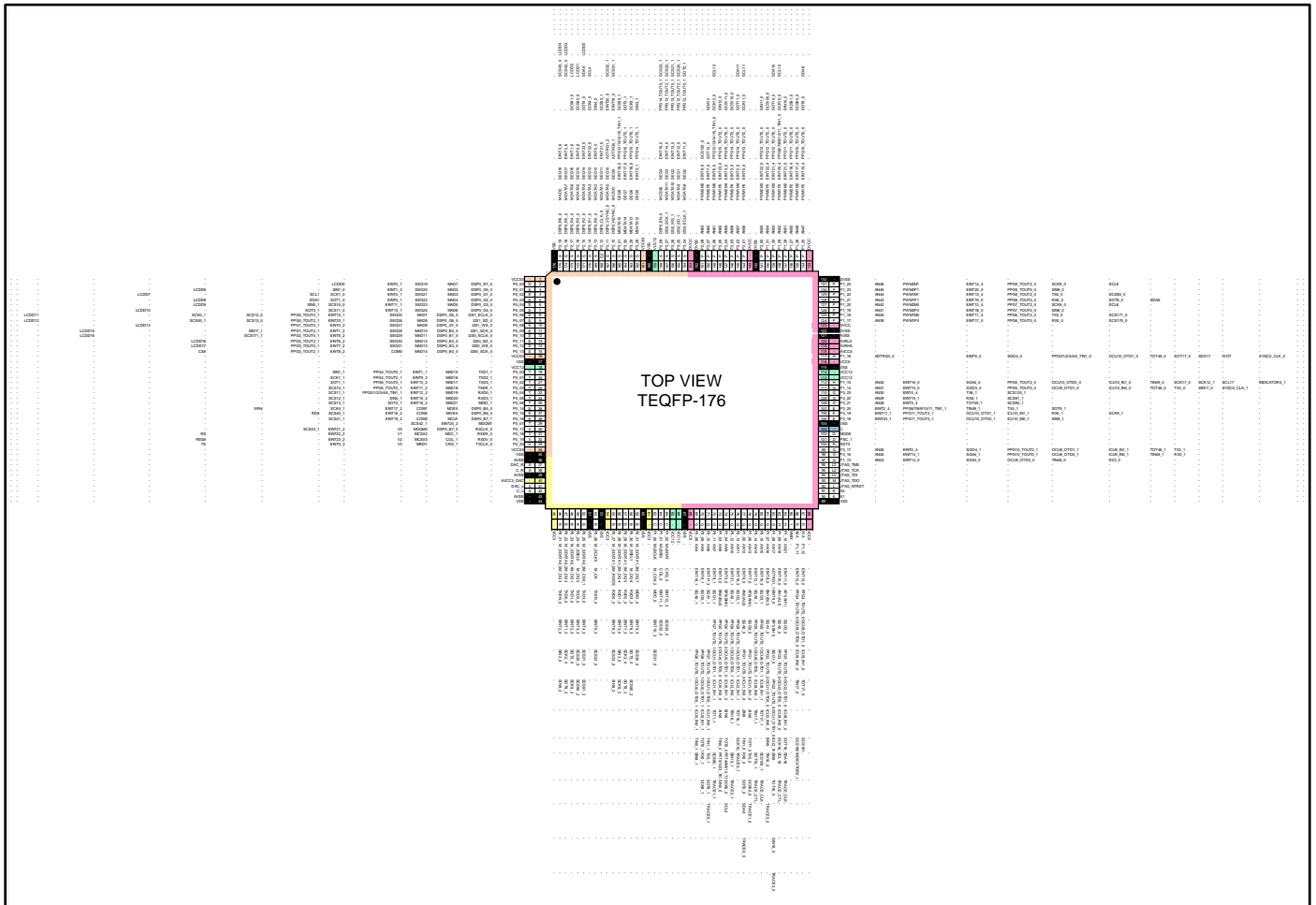
## 4.1.2 TEQFP-176 Pin Assignment

Figure 4-5: TEQFP-176 (S6J331xJyz \*1)



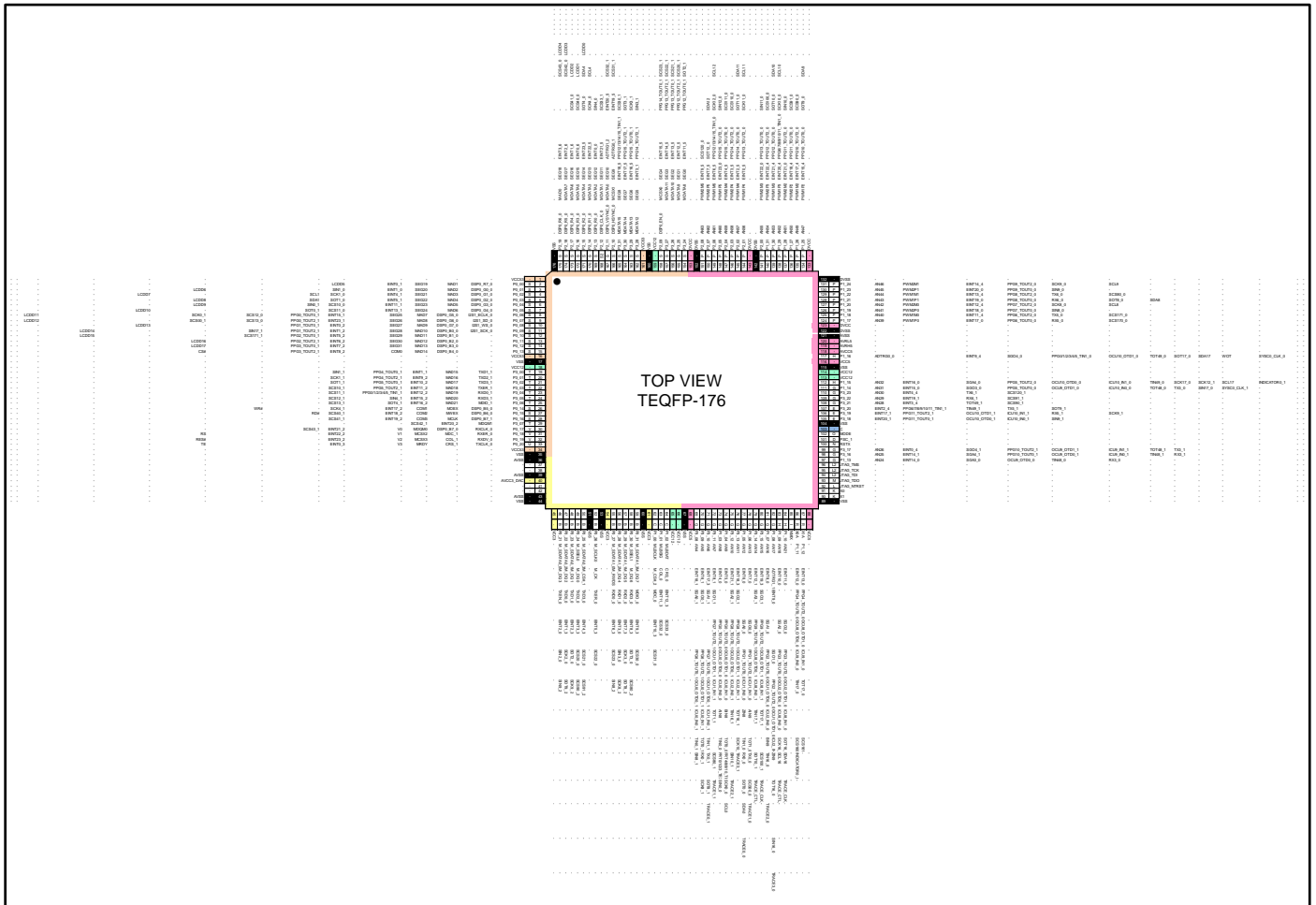
\*1: x, y, z are selected from the following parameters:  
 x: E, D, C, B (Memory Size)  
 y: S, A, B, U, C, D, T, E, F, V, G, H (Option)  
 z: C, D, E (Revision)

Figure 4-6: TEQFP-176 (S6J332xJyz \*1)



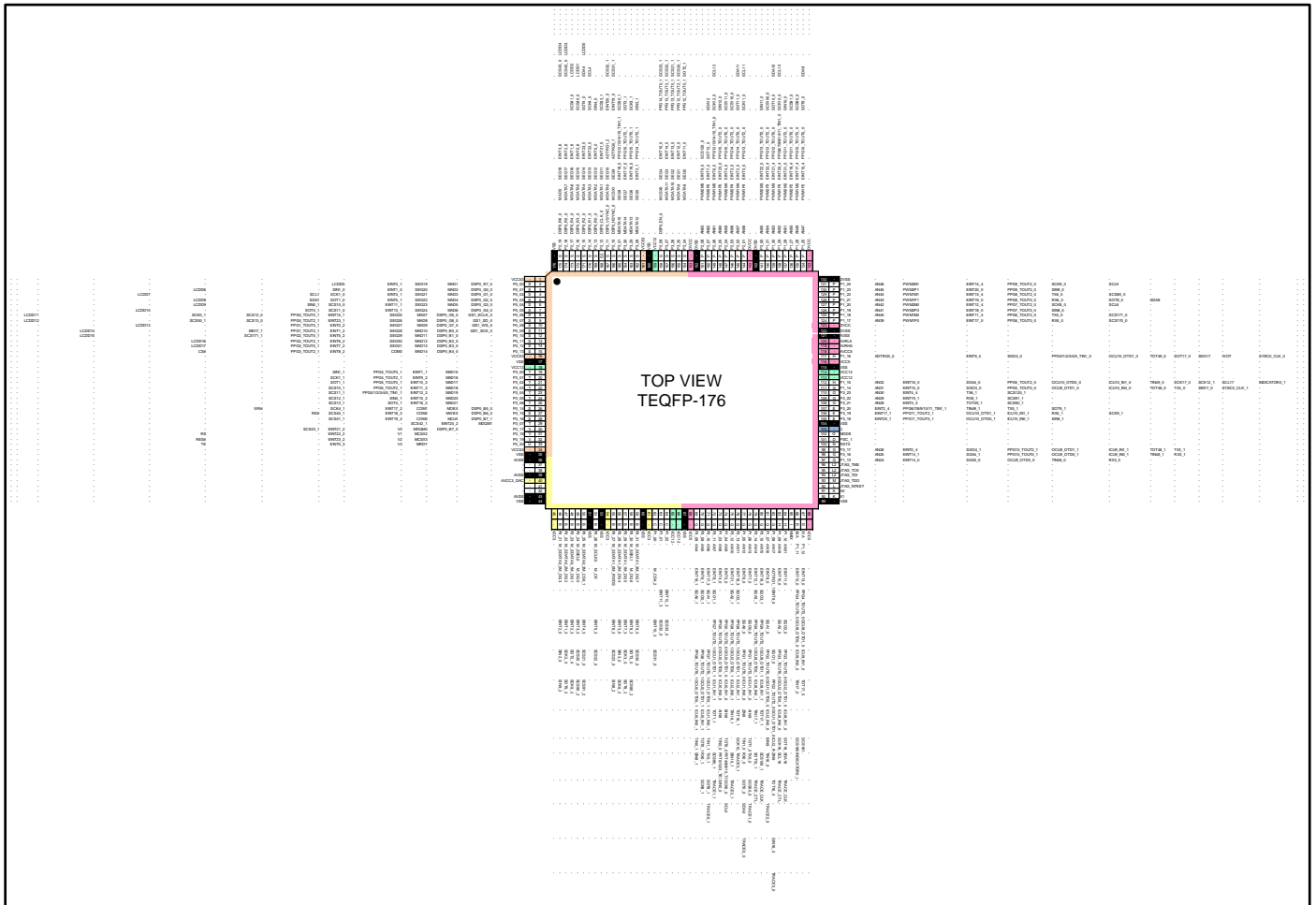
\*1: x, y, z are selected from the following parameters:  
 x: E, D, C, B (Memory Size)  
 y: S, A, B, U, C, D, T, E, F, V, G, H (Option)  
 z: C, D, E (Revision)

Figure 4-7: TEQFP-176 (S6J333xJyz \*1)



\*1: x, y, z are selected from the following parameters:  
 x: E, D, C, B (Memory Size)  
 y: S, A, B, U, C, D, T, E, F, V, G, H (Option)  
 z: C, D, E (Revision)

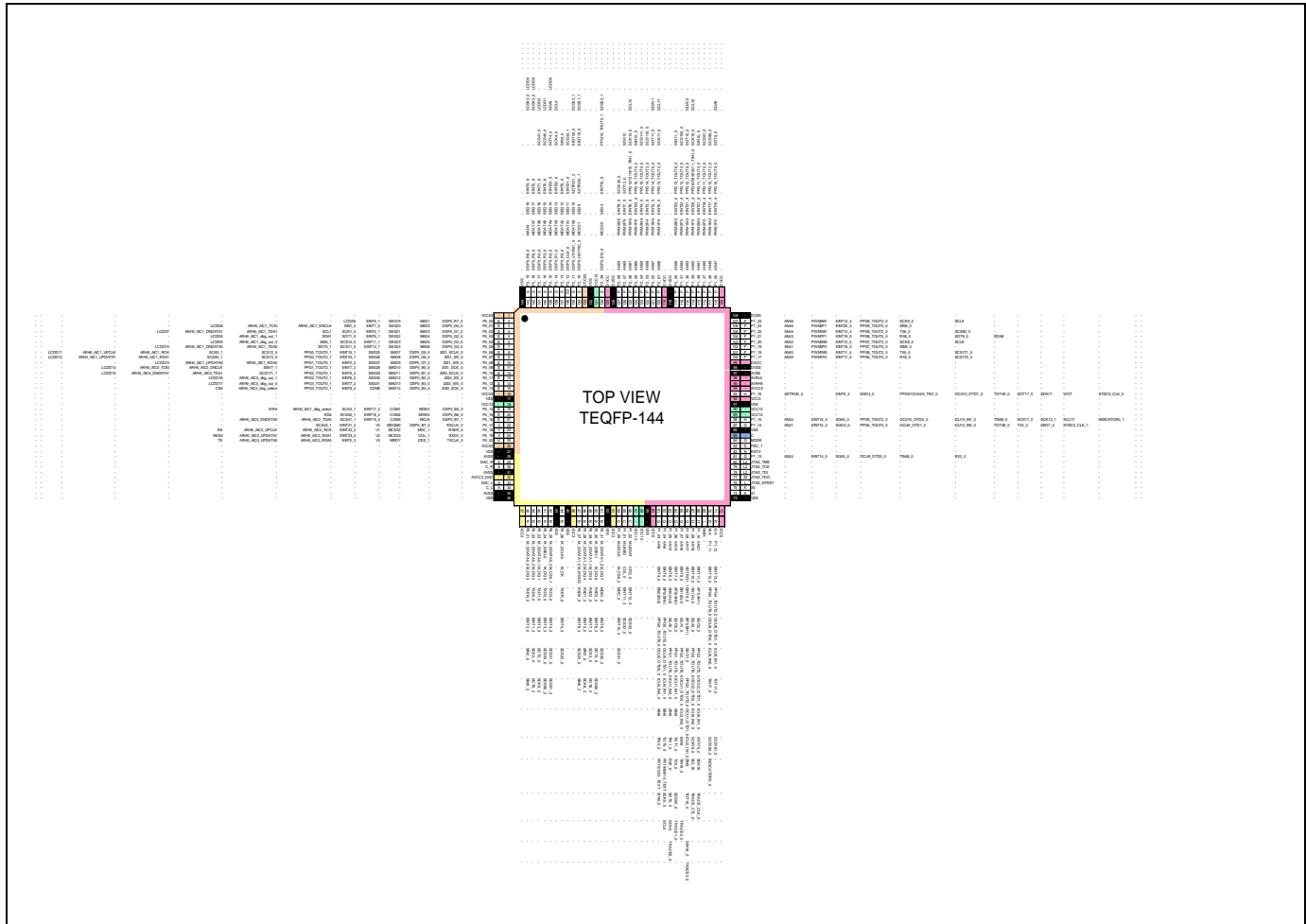
Figure 4-8: TEQFP-176 (S6J334xJyz \*1)



\*1: x, y, z are selected from the following parameters:  
 x: E, D, C, B (Memory Size)  
 y: S, A, B, U, C, D, T, E, F, V, G, H (Option)  
 z: C, D, E (Revision)

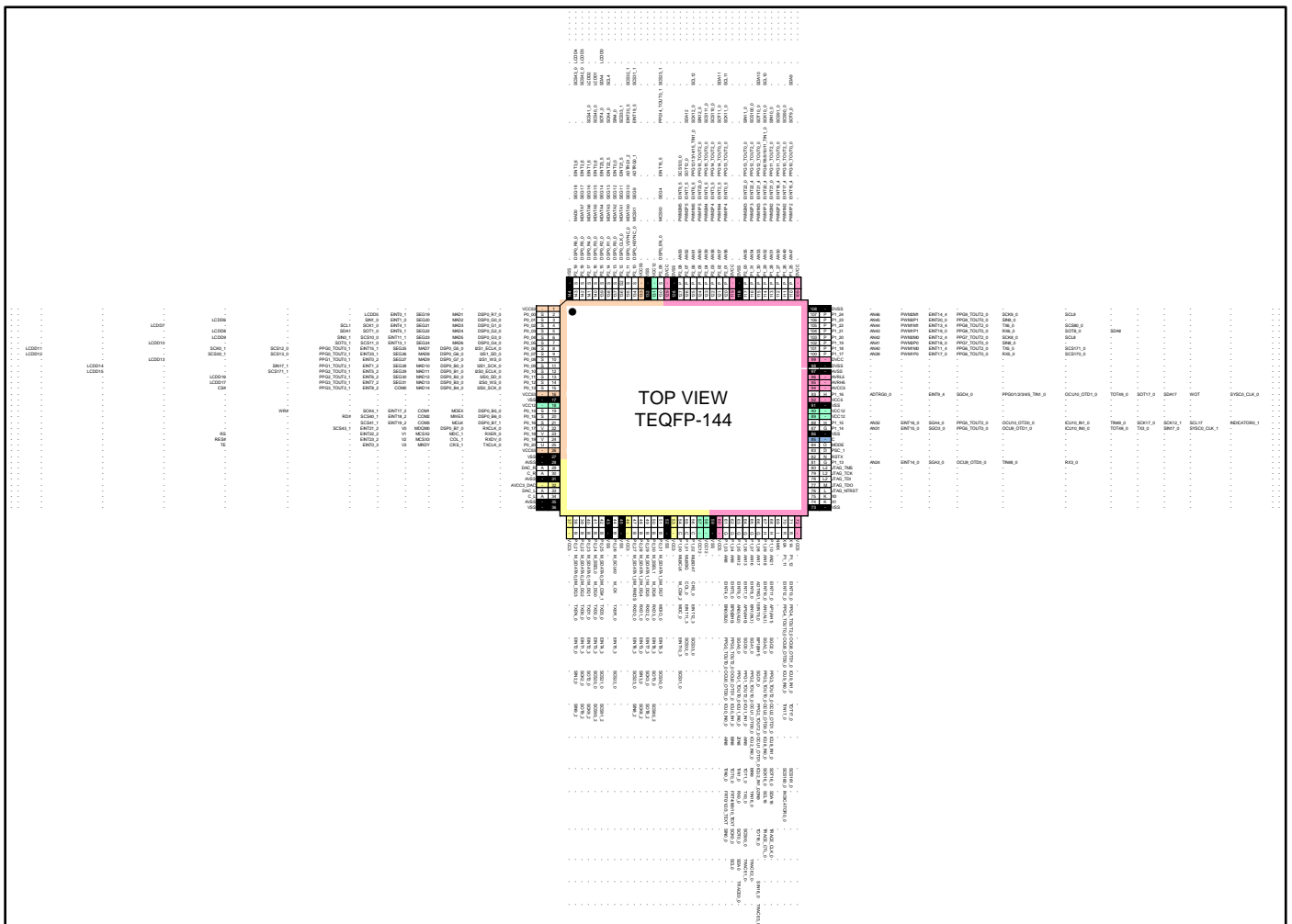
## 4.1.3 TEQFP-144 Pin Assignment

Figure 4-9: TEQFP-144 (S6J331xHyZ \*1)



- \*1: x, y, z are selected from the following parameters:
- x: E, D, C, B (Memory Size)
  - y: S, A, B, U, C, D, T, E, F, V, G, H (Option)
  - z: C, D, E (Revision)

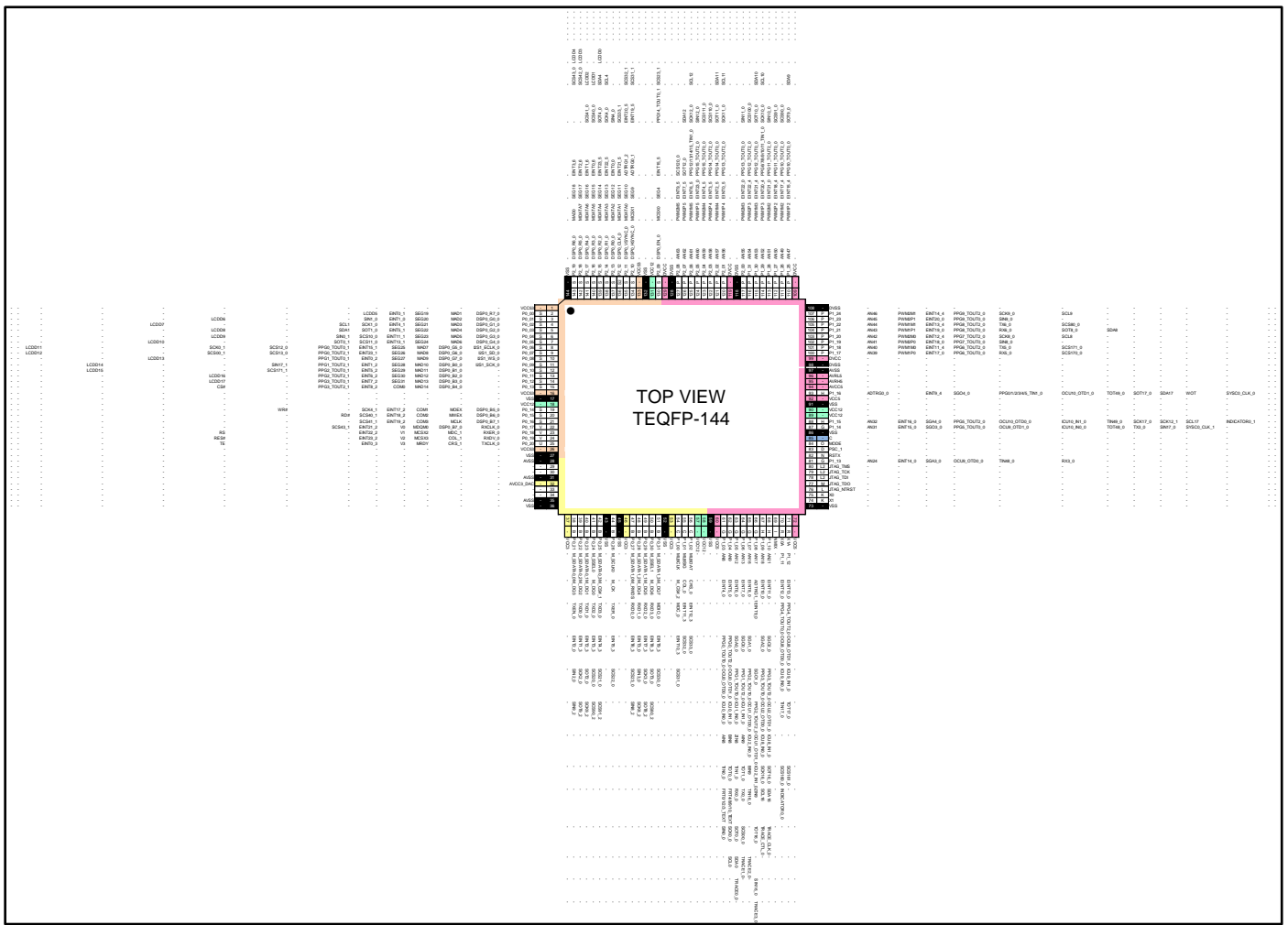
Figure 4-10: TEQFP-144 (S6J332xHyz \*1)



\*1: x, y, z are selected from the following parameters:  
 x: E, D, C, B (Memory Size)  
 y: S, A, B, U, C, D, T, E, F, V, G, H (Option)  
 z: C, D, E (Revision)

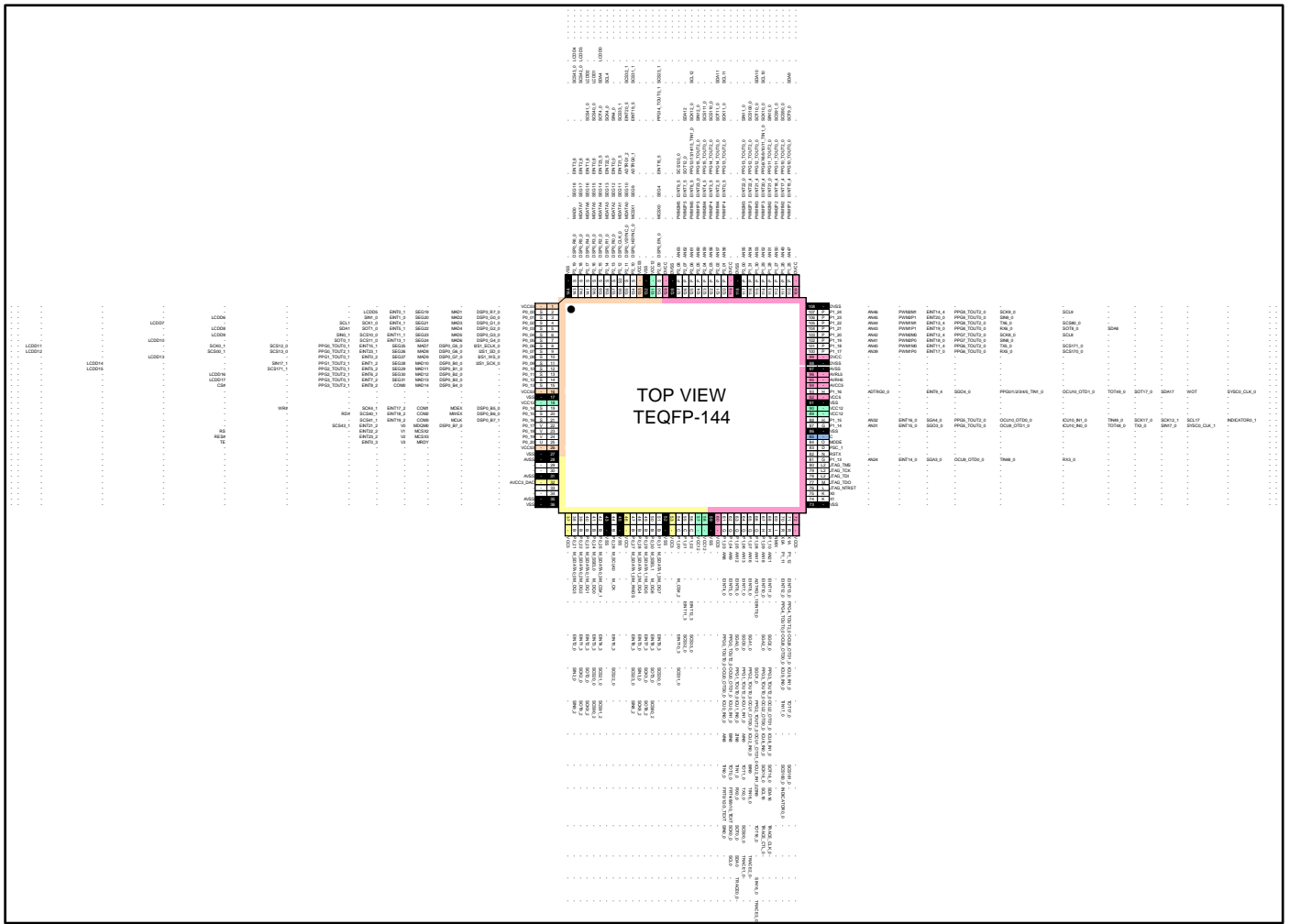


Figure 4-11: TEQFP-144 (S6J333xHyz \*1)



\*1: x, y, z are selected from the following parameters:  
 x: E, D, C, B (Memory Size)  
 y: S, A, B, U, C, D, T, E, F, V, G, H (Option)  
 z: C, D, E (Revision)

Figure 4-12: TEQFP-144 (S6J334xHyZ \*1)



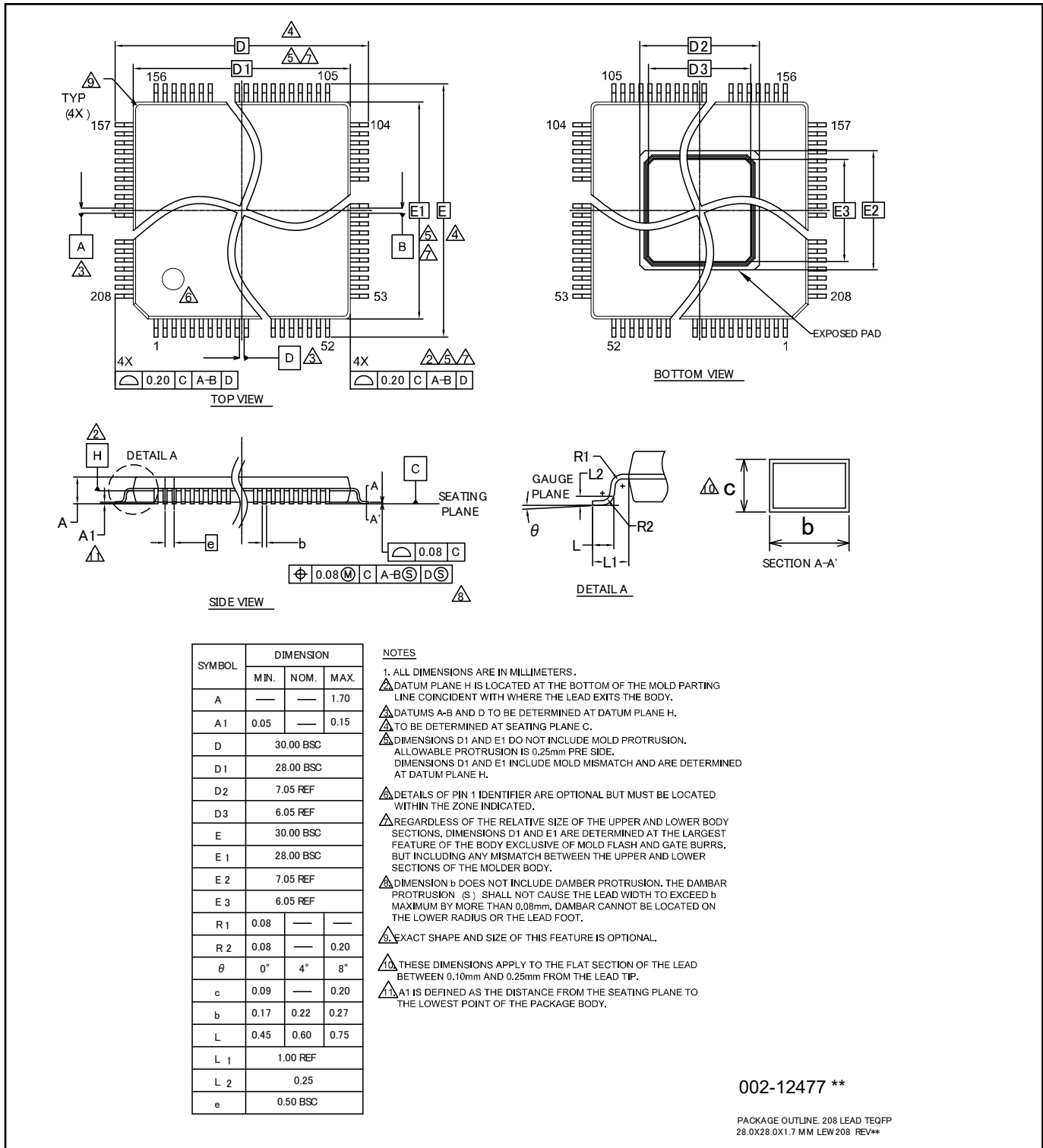
- \*1: x, y, z are selected from the following parameters:
- x: E, D, C, B (Memory Size)
  - y: S, A, B, U, C, D, T, E, F, V, G, H (Option)
  - z: C, D, E (Revision)

## 4.2 Package Dimensions

### 4.2.1 TEQFP208

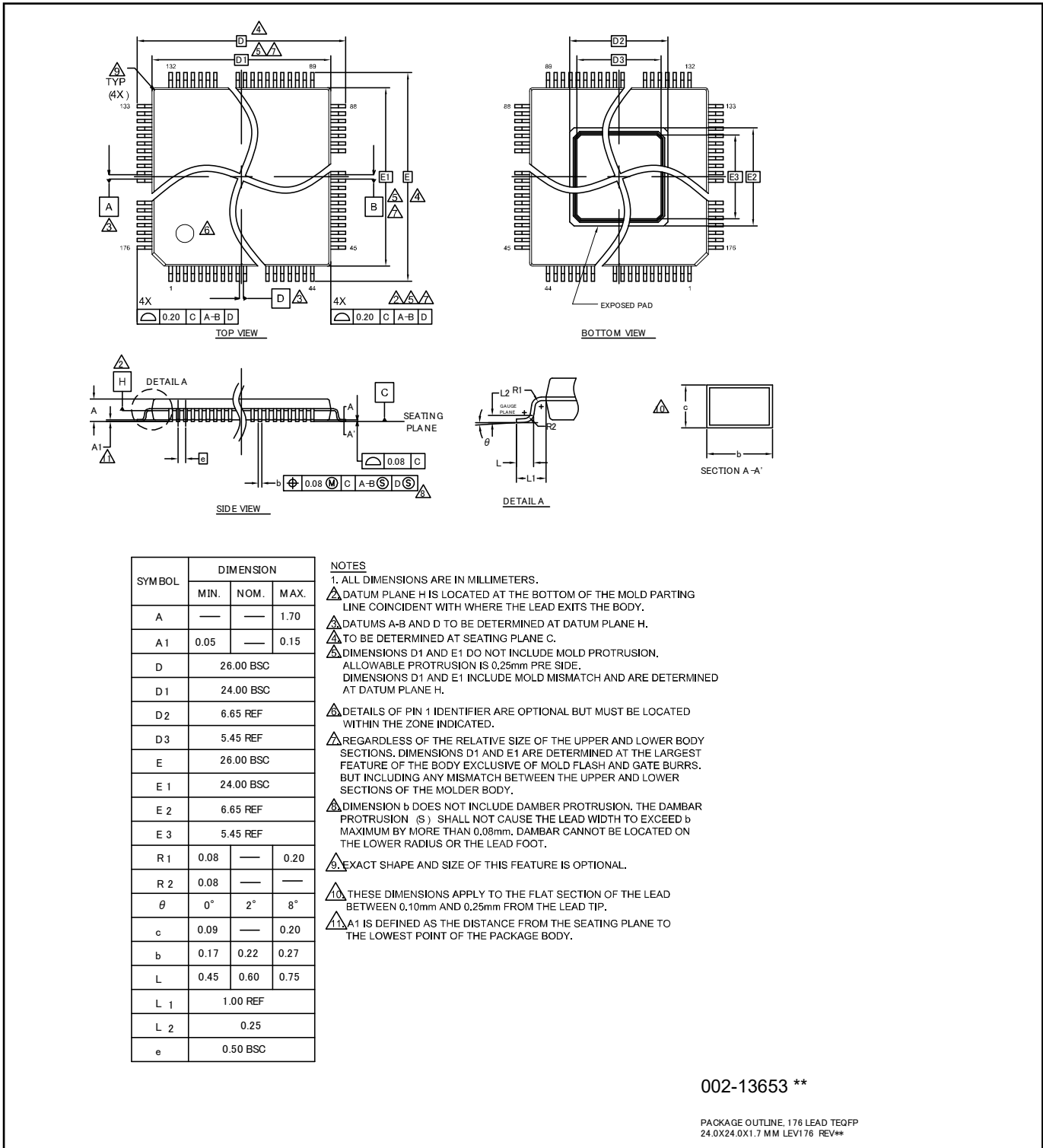
Figure 4-13: TEQFP208

Package Type	Package Code
TEQFP 208 pin	LEW208



**4.2.2 TEQFP176**
**Figure 4-14: TEQFP176**

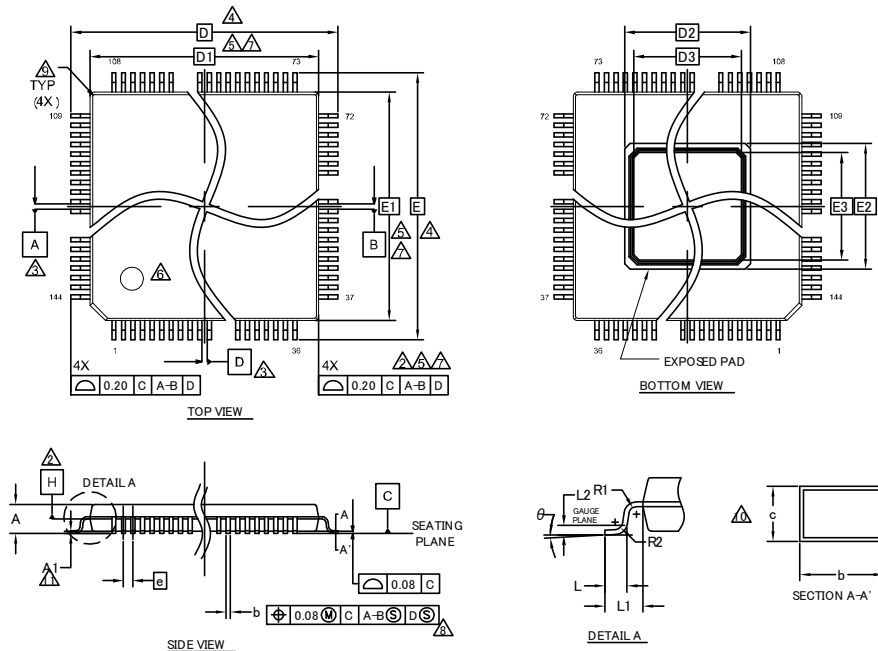
Package Type	Package Code
TEQFP 176 pin	LEV176



4.2.3 TEQFP144

Figure 4-15: TEQFP144 (0.5 mm Pitch)

Package Type	Package Code
TEQFP 144 pin	LEX144



SYMBOL	DIMENSION		
	MIN.	NOM.	MAX.
A	—	—	1.70
A1	0.05	—	0.15
D	22.00 BSC		
D1	20.00 BSC		
D2	5.80 REF		
D3	4.60 REF		
E	22.00 BSC		
E1	20.00 BSC		
E2	5.80 REF		
E3	4.60 REF		
R1	0.08	—	—
R2	0.08	—	0.20
$\theta$	0°	4°	8°
c	0.09	—	0.20
b	0.17	0.22	0.27
L	0.45	0.60	0.75
L1	1.00 REF		
L2	0.25		
e	0.50 BSC		

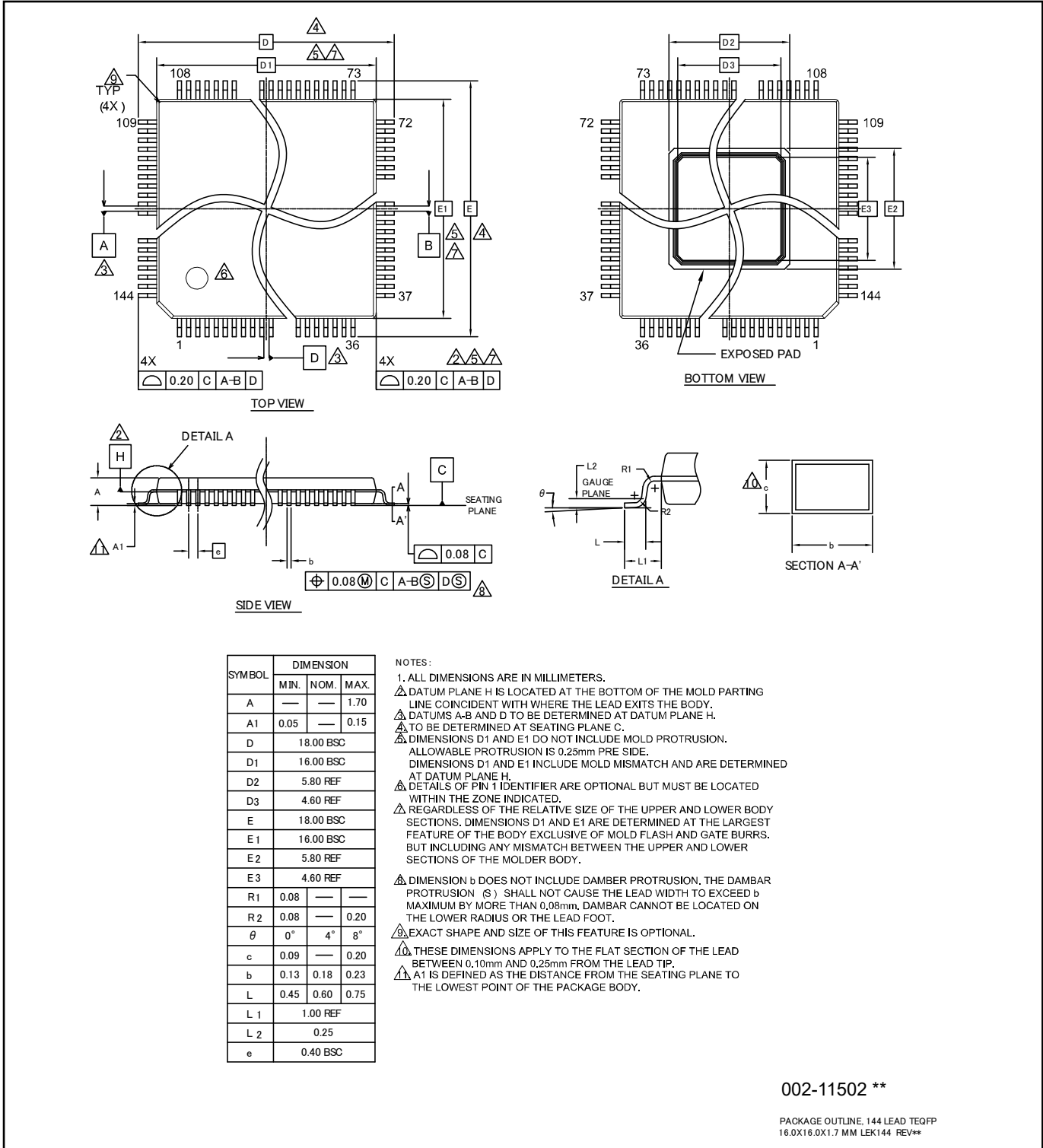
- NOTES**
- ALL DIMENSIONS ARE IN MILLIMETERS.
  - DATUM PLANE H IS LOCATED AT THE BOTTOM OF THE MOLD PARTING LINE COINCIDENT WITH WHERE THE LEAD EXITS THE BODY.
  - DATUMS A-B AND D TO BE DETERMINED AT DATUM PLANE H.
  - TO BE DETERMINED AT SEATING PLANE C.
  - DIMENSIONS D1 AND E1 DO NOT INCLUDE MOLD PROTRUSION. ALLOWABLE PROTRUSION IS 0.25mm PRE SIDE. DIMENSIONS D1 AND E1 INCLUDE MOLD MISMATCH AND ARE DETERMINED AT DATUM PLANE H.
  - DETAILS OF PIN 1 IDENTIFIER ARE OPTIONAL BUT MUST BE LOCATED WITHIN THE ZONE INDICATED.
  - REGARDLESS OF THE RELATIVE SIZE OF THE UPPER AND LOWER BODY SECTIONS, DIMENSIONS D1 AND E1 ARE DETERMINED AT THE LARGEST FEATURE OF THE BODY EXCLUSIVE OF MOLD FLASH AND GATE BURRS, BUT INCLUDING ANY MISMATCH BETWEEN THE UPPER AND LOWER SECTIONS OF THE MOLDER BODY.
  - DIMENSION b DOES NOT INCLUDE DAMBAR PROTRUSION. THE DAMBAR PROTRUSION (S) SHALL NOT CAUSE THE LEAD WIDTH TO EXCEED b MAXIMUM BY MORE THAN 0.08mm. DAMBAR CANNOT BE LOCATED ON THE LOWER RADIUS OR THE LEAD FOOT.
  - EXACT SHAPE AND SIZE OF THIS FEATURE IS OPTIONAL.
  - THESE DIMENSIONS APPLY TO THE FLAT SECTION OF THE LEAD BETWEEN 0.10mm AND 0.25mm FROM THE LEAD TIP.
  - A1 IS DEFINED AS THE DISTANCE FROM THE SEATING PLANE TO THE LOWEST POINT OF THE PACKAGE BODY.

002-13553 \*\*

PACKAGE OUTLINE, 144 LEAD TEQFP  
20.0X20.0X1.7 MM LEX144 REV\*\*

Figure 4-16: TEQFP144 (0.4 mm Pitch)

Package Type	Package Code
TEQFP 144 pin	LEK144



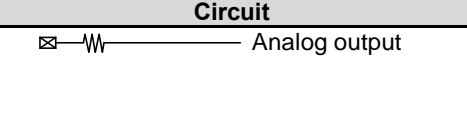
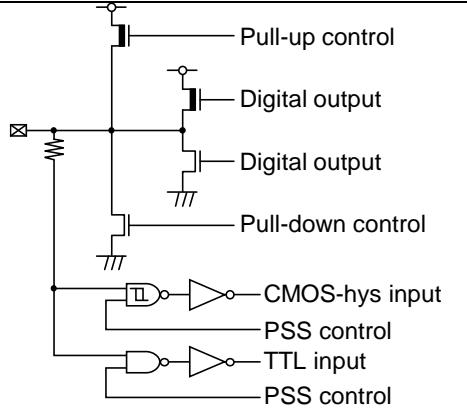
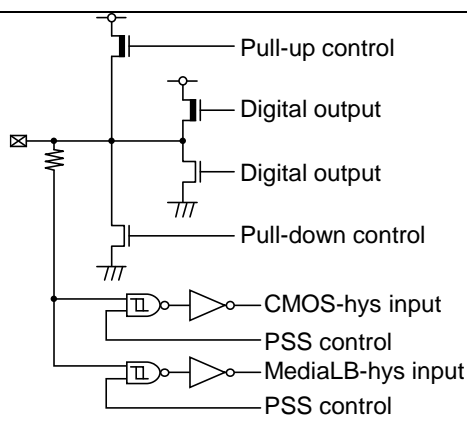
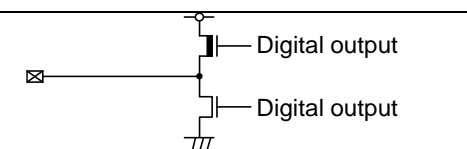
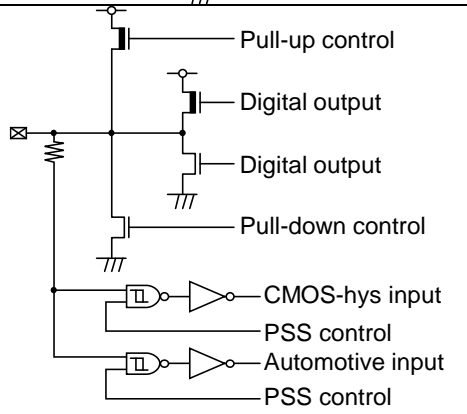
002-11502 \*\*

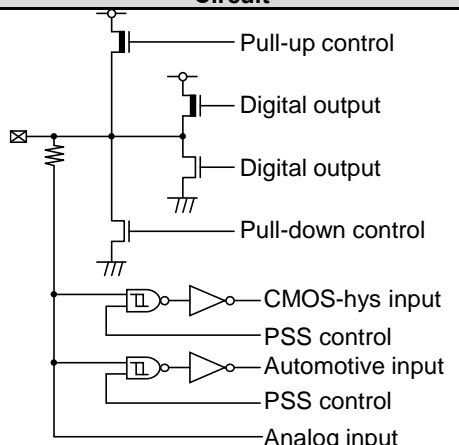
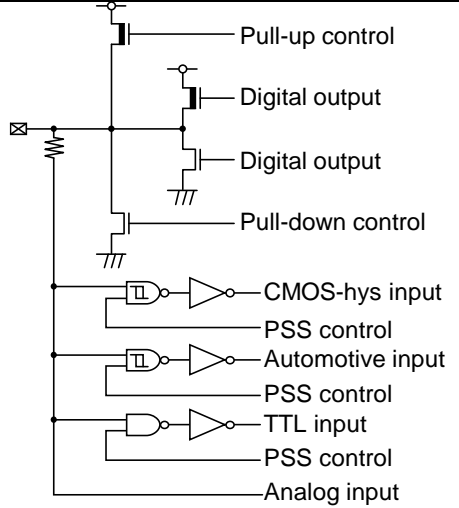
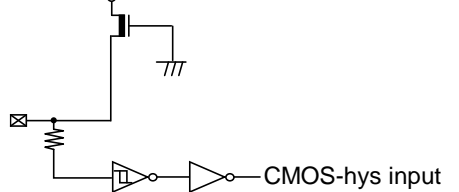
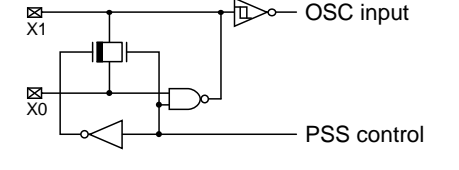
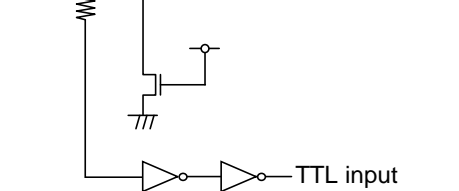
PACKAGE OUTLINE, 144 LEAD TEQFP  
16.0X16.0X1.77 MM LEK144 REV\*\*

## 5. IO Circuit Type

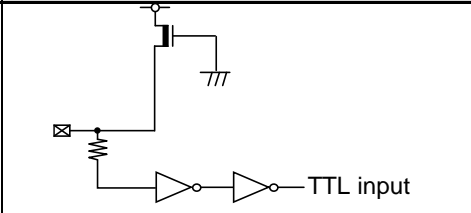
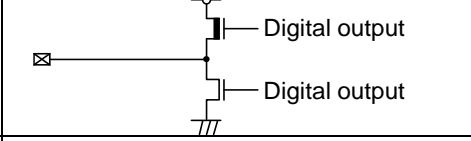
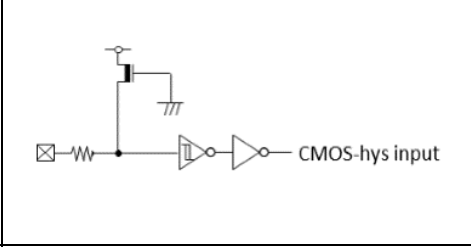
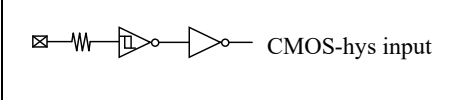
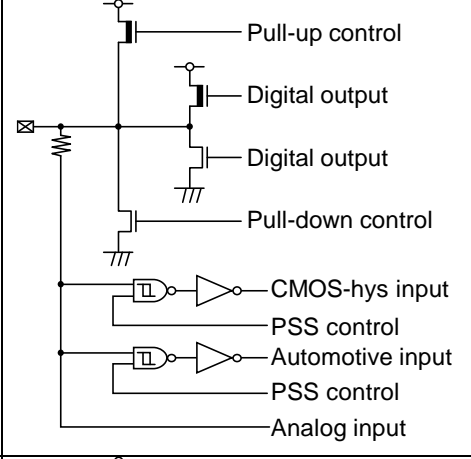
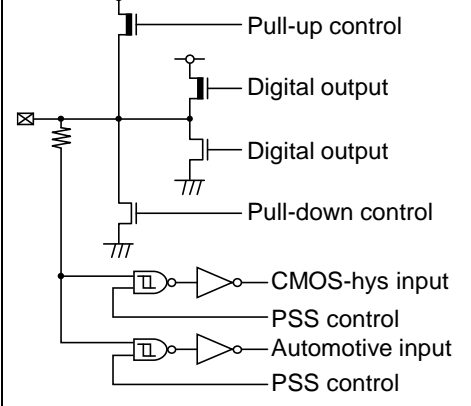
### 5.1 I/O Circuit Type

This section explains I/O circuit types.

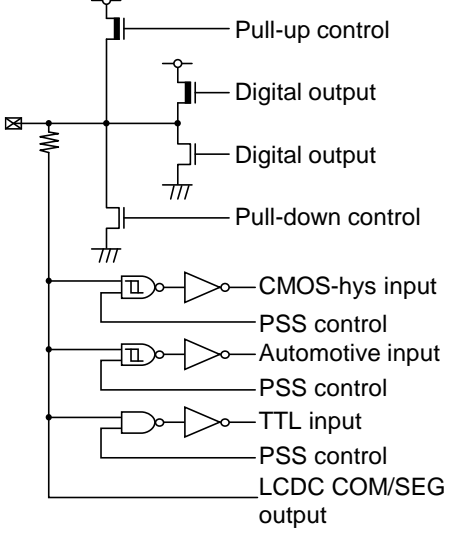
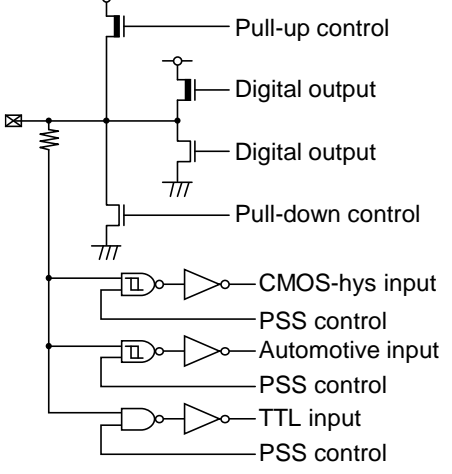
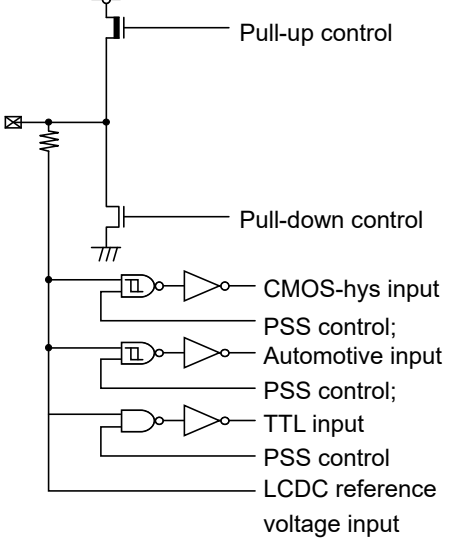
Type	Circuit	Remarks
A	 Analog output	<ul style="list-style-type: none"> <li>- Analog output (3 V)</li> <li>- Audio DAC output</li> </ul>
B	 Pull-up control Digital output Digital output Pull-down control CMOS-hys input PSS control TTL input PSS control	<ul style="list-style-type: none"> <li>- General-purpose I/O port</li> <li>- Output 2 mA, 5 mA, 6 mA or 15 mA selectable</li> <li>- 50 kΩ with pull-up resistor control</li> <li>- 50 kΩ with pull-down resistor control</li> <li>- CMOS hysteresis input</li> <li>- TTL input</li> </ul>
C	 Pull-up control Digital output Digital output Pull-down control CMOS-hys input PSS control MediaLB-hys input PSS control	<ul style="list-style-type: none"> <li>- General-purpose I/O port</li> <li>- Output 2 mA, 5 mA, 6 mA or 15 mA selectable</li> <li>- 50 kΩ with pull-up resistor control</li> <li>- 50 kΩ with pull-down resistor control</li> <li>- CMOS hysteresis input</li> <li>- MediaLB level hysteresis input</li> </ul>
D	 Digital output Digital output	<ul style="list-style-type: none"> <li>- External 1.2 V regulator control</li> <li>- Output 2 mA</li> </ul>
E	 Pull-up control Digital output Digital output Pull-down control CMOS-hys input PSS control Automotive input PSS control	<ul style="list-style-type: none"> <li>- General-purpose I/O port</li> <li>- Output 1 mA, 2 mA or 5 mA selectable</li> <li>- 50 kΩ with pull-up resistor control</li> <li>- 50 kΩ with pull-down resistor control</li> <li>- CMOS hysteresis input</li> <li>- Automotive hysteresis input</li> </ul>

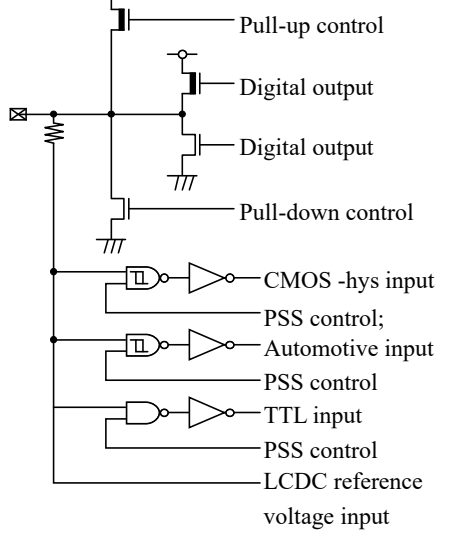
Type	Circuit	Remarks
G		<ul style="list-style-type: none"> <li>- General-purpose I/O port with analog input</li> <li>- Output 1 mA, 2 mA or 5 mA selectable</li> <li>- 50 kΩ with pull-up resistor control</li> <li>- 50 kΩ with pull-down resistor control</li> <li>- CMOS hysteresis input</li> <li>- Automotive hysteresis input</li> </ul>
H		<ul style="list-style-type: none"> <li>- General-purpose I/O port with analog input</li> <li>- Output 1 mA, 2 mA, 3 mA (I<sup>2</sup>C) or 5 mA selectable</li> <li>- 50 kΩ with pull-up resistor control</li> <li>- 50 kΩ with pull-down resistor control</li> <li>- CMOS hysteresis input</li> <li>- Automotive hysteresis input</li> <li>- TTL input</li> </ul>
I		<ul style="list-style-type: none"> <li>- 50 kΩ with pull-up</li> <li>- CMOS hysteresis input</li> </ul>
K		<ul style="list-style-type: none"> <li>- Main oscillation I/O</li> </ul>
L		<ul style="list-style-type: none"> <li>- JTAG_NTRST</li> <li>- 50 kΩ with pull-down</li> <li>- TTL input</li> </ul>



Type	Circuit	Remarks
L2		<ul style="list-style-type: none"> <li>- JTAG_TDI/TMS/TCK</li> <li>- 50 kΩ with pull-up</li> <li>- TTL input</li> </ul>
M		<ul style="list-style-type: none"> <li>- JTAG_TDO</li> <li>- Output 5 mA</li> </ul>
N		<ul style="list-style-type: none"> <li>- RSTX input</li> <li>- 50 kΩ with pull-up</li> <li>- CMOS hysteresis input</li> </ul>
O		<ul style="list-style-type: none"> <li>- CMOS hysteresis input</li> </ul>
P		<ul style="list-style-type: none"> <li>- General-purpose I/O port with analog input</li> <li>- Output 1 mA, 2 mA, 5 mA or 30 mA selectable</li> <li>- 50 kΩ with pull-up resistor control</li> <li>- 50 kΩ with pull-down resistor control</li> <li>- CMOS hysteresis input</li> <li>- Automotive hysteresis input</li> </ul>
Q		<ul style="list-style-type: none"> <li>- General-purpose I/O port</li> <li>- Output 1 mA, 2 mA, 5 mA or 30 mA selectable</li> <li>- 50 kΩ with pull-up resistor control</li> <li>- 50 kΩ with pull-down resistor control</li> <li>- CMOS hysteresis input</li> <li>- Automotive hysteresis input</li> </ul>

Type	Circuit	Remarks
R		<ul style="list-style-type: none"> <li>- Sub oscillation I/O shared General-purpose I/O port</li> <li>- Output 1 mA, 2 mA or 5 mA selectable</li> <li>- 50 kΩ with pull-up resistor control</li> <li>- 50 kΩ with pull-down resistor control</li> <li>- CMOS hysteresis input</li> <li>- Automotive hysteresis input</li> </ul>
S		<ul style="list-style-type: none"> <li>- General-purpose I/O port with LCDC COM/SEG output</li> <li>- Output 1 mA, 2 mA or 5 mA selectable</li> <li>- 50 kΩ with pull-up resistor control</li> <li>- 50 kΩ with pull-down resistor control</li> <li>- CMOS hysteresis input</li> <li>- Automotive hysteresis input</li> <li>- TTL input</li> </ul>

Type	Circuit	Remarks
S2	 <p>           Pull-up control            Digital output            Digital output            Pull-down control            CMOS-hys input            PSS control            Automotive input            PSS control            TTL input            PSS control            LCDC COM/SEG output         </p>	<ul style="list-style-type: none"> <li>- General-purpose I/O port with LCDC COM/SEG output</li> <li>- Output 1 mA, 2 mA, 5 mA or 15 mA selectable</li> <li>- 50 kΩ with pull-up resistor control</li> <li>- 50 kΩ with pull-down resistor control</li> <li>- CMOS hysteresis input</li> <li>- Automotive hysteresis input</li> <li>- TTL input</li> </ul>
T	 <p>           Pull-up control            Digital output            Digital output            Pull-down control            CMOS-hys input            PSS control            Automotive input            PSS control            TTL input            PSS control         </p>	<ul style="list-style-type: none"> <li>- General-purpose I/O port</li> <li>- Output 1 mA, 2 mA or 5 mA selectable</li> <li>- 50 kΩ with pull-up resistor control</li> <li>- 50 kΩ with pull-down resistor control</li> <li>- CMOS hysteresis input</li> <li>- Automotive hysteresis input</li> <li>- TTL input</li> </ul>
U	 <p>           Pull-up control            Pull-down control            CMOS-hys input            PSS control;            Automotive input            PSS control;            TTL input            PSS control            LCDC reference voltage input         </p>	<ul style="list-style-type: none"> <li>- General-purpose input port with LCDC reference voltage input</li> <li>- 50 kΩ with pull-up resistor control</li> <li>- 50 kΩ with pull-down resistor control</li> <li>- CMOS hysteresis input</li> <li>- Automotive hysteresis input</li> <li>- TTL input</li> </ul>

Type	Circuit	Remarks
V		<ul style="list-style-type: none"> <li>- General-purpose I/O port with LCDC reference voltage input</li> <li>- Output 1 mA, 2 mA or 5 mA selectable</li> <li>- 50 kΩ with pull-up resistor control</li> <li>- 50 kΩ with pull-down resistor control</li> <li>- CMOS hysteresis input</li> <li>- Automotive hysteresis input</li> <li>- TTL input</li> </ul>

**5.2 Note**

Alphabet which shows I/O circuit type is described with corresponding pin number in pin assignment figure.

## 6. Port Description

### 6.1 Port Description List

The table shows the port function of description which is supported. The port function which is not described in the table is not supported for the product.

**Table 6-1 S6J3310 Series**

Port Name	Description	Package Pin Number			Remark
		TEQFP 144	TEQFP 176	TEQFP 208	
VCC12	1.2 V external power supply pin	18, 57, 58, 89, 90, 131	18, 65, 66, 113, 114, 159	24, 73, 74, 132, 133, 191	
VCC5	5 V external power supply pin	60, 72, 92	68, 88, 116	76, 104, 135,	
VCC3	3 V external power supply pin	37, 46, 53	45, 54, 61	53, 62, 69	
VCC53	3 V/5 V external power supply pin	1, 16, 26, 133	1, 16, 34, 161	1, 22, 42, 193	
VSS	GND	17, 27, 36, 43, 45, 52, 59, 73, 86, 91, 132, 144	17, 35, 44, 51, 53, 60, 67, 89, 104, 115, 160, 176	23, 43, 52, 59, 61, 68, 75, 105, 121, 134, 192, 208	
AVCC3_DAC	Audio DAC power supply pin	32	40	48	
AVCC5	A/D converter analog power supply pin	94	118	142	
AVRH5	A/D converter upper limit reference voltage pin	95	119	143	
AVRL5	A/D converter lower limit reference voltage pin	96	120	144	
AVSS	A/D converter GND	28, 31, 35, 97	36, 39, 43, 121	44, 47, 51, 145	
DVCC	SMC large current port power supply pin	99, 109, 119, 129	123, 133, 143, 153	147, 157, 170, 183	
DVSS	SMC large current port GND	98, 108, 118, 128	122, 132, 142, 152	146, 156, 169, 182	
X1	Main clock oscillator output pin	74	90	106	
X0	Main clock oscillator input pin	75	91	107	
X1A	Sub-clock oscillator output	71	87	103	
X0A	Sub-clock oscillator input	70	86	102	
NMIX	Non-maskable interrupt input pin	69	85	101	

Port Name	Description	Package Pin Number			Remark
		TEQFP 144	TEQFP 176	TEQFP 208	
RSTX	External reset input pin	82	100	117	
PSC_1	External Power Supply Control pin	83	101	118	
MODE	Mode Pin	84	102	119	
C	External capacity connection output pin	85	103	120	
JTAG_NTRST	JTAG test reset input pin	76	92	108	
JTAG_TDO	JTAG test data output pin	77	93	109	
JTAG_TDI	JTAG test data input pin	78	94	110	
JTAG_TCK	JTAG test clock input pin	79	95	111	
JTAG_TMS	JTAG test mode state input pin	80	96	112	
TRACE0_0	Trace data 0 output pin (0)	63	77	89	
TRACE1_0	Trace data 1 output pin (0)	64	78	90	
TRACE2_0	Trace data 2 output pin (0)	65	81	93	
TRACE3_0	Trace data 3 output pin (0)	66	82	94	
TRACE_CLK_0	Trace clock (0)	68	84	98	
TRACE_CTL_0	Trace control (0)	67	83	95	
TRACE0_1	Trace data 0 output pin (1)	-	71	83	
TRACE1_1	Trace data 1 output pin (1)	-	72	84	
TRACE2_1	Trace data 2 output pin (1)	-	75	87	
TRACE3_1	Trace data 3 output pin (1)	-	76	88	
TRACE_CLK_1	Trace clock (1)	-	80	92	
TRACE_CTL_1	Trace control (1)	-	79	91	
ADTRG0_0	A/D converter external trigger input pin (0)	93	117	139	
ADTRG1_0	A/D converter external trigger input pin (0)	-	-	140	
ADTRG0_1	A/D converter external trigger input pin (1)	134	166	198	
ADTRG1_1	A/D converter external trigger input pin (1)	66	82	94	
ADTRG1_2	A/D converter external trigger input pin (2)	135	167	199	
AN4	ADC Unit0 ch.4 input pin	-	69	81	
AN5	ADC Unit0 ch.5 input pin	-	70	82	
AN6	ADC Unit0 ch.6 input pin	-	71	83	
AN7	ADC Unit0 ch.7 input pin	-	72	84	
AN8	ADC Unit0 ch.8 input pin	61	73	85	
AN9	ADC Unit0 ch.9 input pin	62	74	86	
AN10	ADC Unit0 ch.10 input pin	-	75	87	
AN11	ADC Unit0 ch.11 input pin	-	76	88	
AN12	ADC Unit0 ch.12 input pin	63	77	89	
AN13	ADC Unit0 ch.13 input pin	64	78	90	
AN14	ADC Unit0 ch.14 input pin	-	79	91	
AN15	ADC Unit0 ch.15 input pin	-	80	92	
AN16	ADC Unit0 ch.16 input pin	65	81	93	
AN17	ADC Unit0 ch.17 input pin	66	82	94	
AN18	ADC Unit0 ch.18 input pin	67	83	95	
AN21	ADC Unit0 ch.21 input pin	68	84	98	
AN24	ADC Unit0 ch.24 input pin	81	97	113	
AN25	ADC Unit0 ch.25 input pin	-	98	114	
AN26	ADC Unit0 ch.26 input pin	-	99	115	
AN28	ADC Unit0 ch.28 input pin	-	108	125	
AN29	ADC Unit0 ch.29 input pin	-	109	126	
AN30	ADC Unit0 ch.30 input pin	-	110	127	
AN31	ADC Unit0 ch.31 input pin	87	111	128	

Port Name	Description	Package Pin Number			Remark
		TEQFP 144	TEQFP 176	TEQFP 208	
AN32	ADC Unit1 ch.32 input pin	88	112	129	
AN39	ADC Unit1 ch.39 input pin	100	124	148	
AN40	ADC Unit1 ch.40 input pin	101	125	149	
AN41	ADC Unit1 ch.41 input pin	102	126	150	
AN42	ADC Unit1 ch.42 input pin	103	127	151	
AN43	ADC Unit1 ch.43 input pin	104	128	152	
AN44	ADC Unit1 ch.44 input pin	105	129	153	
AN45	ADC Unit1 ch.45 input pin	106	130	154	
AN46	ADC Unit1 ch.46 input pin	107	131	155	
AN47	ADC Unit1 ch.47 input pin	110	134	158	
AN49	ADC Unit1 ch.49 input pin	111	135	160	
AN50	ADC Unit1 ch.50 input pin	112	136	161	
AN51	ADC Unit1 ch.51 input pin	113	137	162	
AN52	ADC Unit1 ch.52 input pin	114	138	164	
AN53	ADC Unit1 ch.53 input pin	115	139	165	
AN54	ADC Unit1 ch.54 input pin	116	140	166	
AN55	ADC Unit1 ch.55 input pin	117	141	168	
AN56	ADC Unit1 ch.56 input pin	120	144	171	
AN57	ADC Unit1 ch.57 input pin	121	145	173	
AN58	ADC Unit1 ch.58 input pin	122	146	174	
AN59	ADC Unit1 ch.59 input pin	123	147	175	
AN60	ADC Unit1 ch.60 input pin	124	148	177	
AN61	ADC Unit1 ch.61 input pin	125	149	178	
AN62	ADC Unit1 ch.62 input pin	126	150	179	
AN63	ADC Unit1 ch.63 input pin	127	151	181	
TX0_0	CAN transmission data 0 output pin (0)	64	78	90	
TX1_0	CAN transmission data 1 output pin (0)	-	-	94	
TX2_0	CAN transmission data 2 output pin (0)	-	-	103	
TX3_0	CAN transmission data 3 output pin (0)	87	111	128	
TX5_0	CAN transmission data 5 output pin (0)	101	125	149	
TX6_0	CAN transmission data 6 output pin (0)	105	129	153	
TX0_1	CAN transmission data 0 output pin (1)	-	71	83	
TX1_1	CAN transmission data 1 output pin (1)	-	-	87	
TX2_1	CAN transmission data 2 output pin (1)	-	-	92	
TX3_1	CAN transmission data 3 output pin (1)	-	99	115	
TX5_1	CAN transmission data 5 output pin (1)	-	107	124	
TX6_1	CAN transmission data 6 output pin (1)	-	110	127	
TX0_2	CAN transmission data 0 output pin (2)	-	-	7	
TX3_2	CAN transmission data 3 output pin (2)	-	-	16	
RX0_0	CAN reception data 0 input pin (0)	63	77	89	
RX1_0	CAN reception data 1 input pin (0)	-	-	93	
RX2_0	CAN reception data 2 input pin (0)	-	-	102	
RX3_0	CAN reception data 3 input pin (0)	81	97	113	
RX5_0	CAN reception data 5 input pin (0)	100	124	148	
RX6_0	CAN reception data 6 input pin (0)	104	128	152	
RX0_1	CAN reception data 0 input pin (1)	-	70	82	
RX1_1	CAN reception data 1 input pin (1)	-	-	84	
RX2_1	CAN reception data 2 input pin (1)	-	-	91	
RX3_1	CAN reception data 3 input pin (1)	-	98	114	

Port Name	Description	Package Pin Number			Remark
		TEQFP 144	TEQFP 176	TEQFP 208	
RX5_1	CAN reception data 5 input pin (1)	-	106	123	
RX6_1	CAN reception data 6 input pin (1)	-	109	126	
RX0_2	CAN reception data 0 input pin (2)	-	-	6	
RX3_2	CAN reception data 3 input pin (2)	-	-	15	
EINT0_0	External interrupt input pin (0)	137	169	201	
EINT1_0	External interrupt input pin (0)	3	3	3	
EINT2_0	External interrupt input pin (0)	38	46	54	
EINT3_0	External interrupt input pin (0)	48	56	64	
EINT4_0	External interrupt input pin (0)	61	73	85	
EINT5_0	External interrupt input pin (0)	62	74	86	
EINT6_0	External interrupt input pin (0)	63	77	89	
EINT7_0	External interrupt input pin (0)	64	78	90	
EINT8_0	External interrupt input pin (0)	65	81	93	
EINT9_0	External interrupt input pin (0)	66	82	94	
EINT10_0	External interrupt input pin (0)	67	83	95	
EINT11_0	External interrupt input pin (0)	68	84	98	
EINT12_0	External interrupt input pin (0)	70	86	102	
EINT13_0	External interrupt input pin (0)	71	87	103	
EINT14_0	External interrupt input pin (0)	81	97	113	
EINT15_0	External interrupt input pin (0)	87	111	128	
EINT16_0	External interrupt input pin (0)	88	112	129	
EINT17_0	External interrupt input pin (0)	100	124	148	
EINT18_0	External interrupt input pin (0)	102	126	150	
EINT19_0	External interrupt input pin (0)	104	128	152	
EINT20_0	External interrupt input pin (0)	106	130	154	
EINT21_0	External interrupt input pin (0)	113	137	162	
EINT22_0	External interrupt input pin (0)	117	141	168	
EINT23_0	External interrupt input pin (0)	124	148	177	
EINT0_1	External interrupt input pin (1)	2	2	2	
EINT1_1	External interrupt input pin (1)	-	19	25	
EINT2_1	External interrupt input pin (1)	-	-	184	
EINT3_1	External interrupt input pin (1)	-	162	194	
EINT4_1	External interrupt input pin (1)	4	4	4	
EINT5_1	External interrupt input pin (1)	5	5	5	
EINT6_1	External interrupt input pin (1)	-	70	82	
EINT7_1	External interrupt input pin (1)	-	-	6	
EINT8_1	External interrupt input pin (1)	-	72	84	
EINT9_1	External interrupt input pin (1)	-	-	7	
EINT10_1	External interrupt input pin (1)	-	-	8	
EINT11_1	External interrupt input pin (1)	6	6	9	
EINT12_1	External interrupt input pin (1)	-	79	91	
EINT13_1	External interrupt input pin (1)	7	7	10	
EINT14_1	External interrupt input pin (1)	-	98	114	
EINT15_1	External interrupt input pin (1)	8	8	11	
EINT16_1	External interrupt input pin (1)	-	-	136	
EINT17_1	External interrupt input pin (1)	-	106	123	
EINT18_1	External interrupt input pin (1)	-	69	81	
EINT19_1	External interrupt input pin (1)	-	109	126	
EINT20_1	External interrupt input pin (1)	-	105	122	



Port Name	Description	Package Pin Number			Remark
		TEQFP 144	TEQFP 176	TEQFP 208	
EINT21_1	External interrupt input pin (1)	-	75	87	
EINT22_1	External interrupt input pin (1)	-	-	140	
EINT23_1	External interrupt input pin (1)	9	9	12	
EINT0_2	External interrupt input pin (2)	10	10	13	
EINT1_2	External interrupt input pin (2)	11	11	14	
EINT2_2	External interrupt input pin (2)	-	-	15	
EINT3_2	External interrupt input pin (2)	-	-	16	
EINT4_2	External interrupt input pin (2)	-	-	17	
EINT5_2	External interrupt input pin (2)	12	12	18	
EINT6_2	External interrupt input pin (2)	13	13	19	
EINT7_2	External interrupt input pin (2)	14	14	20	
EINT8_2	External interrupt input pin (2)	15	15	21	
EINT9_2	External interrupt input pin (2)	-	20	26	
EINT10_2	External interrupt input pin (2)	-	21	27	
EINT11_2	External interrupt input pin (2)	-	22	28	
EINT12_2	External interrupt input pin (2)	-	23	29	
EINT13_2	External interrupt input pin (2)	-	-	30	
EINT14_2	External interrupt input pin (2)	-	-	31	
EINT15_2	External interrupt input pin (2)	-	24	32	
EINT16_2	External interrupt input pin (2)	-	25	33	
EINT17_2	External interrupt input pin (2)	19	26	34	
EINT18_2	External interrupt input pin (2)	20	27	35	
EINT19_2	External interrupt input pin (2)	21	28	36	
EINT20_2	External interrupt input pin (2)	-	29	37	
EINT21_2	External interrupt input pin (2)	22	30	38	
EINT22_2	External interrupt input pin (2)	23	31	39	
EINT23_2	External interrupt input pin (2)	24	32	40	
EINT0_3	External interrupt input pin (3)	25	33	41	
EINT1_3	External interrupt input pin (3)	39	47	55	
EINT2_3	External interrupt input pin (3)	40	48	56	
EINT3_3	External interrupt input pin (3)	41	49	57	
EINT4_3	External interrupt input pin (3)	42	50	58	
EINT5_3	External interrupt input pin (3)	44	52	60	
EINT6_3	External interrupt input pin (3)	47	55	63	
EINT7_3	External interrupt input pin (3)	49	57	65	
EINT8_3	External interrupt input pin (3)	50	58	66	
EINT9_3	External interrupt input pin (3)	51	59	67	
EINT10_3	External interrupt input pin (3)	54	62	70	
EINT11_3	External interrupt input pin (3)	55	63	71	
EINT12_3	External interrupt input pin (3)	56	64	72	
EINT13_3	External interrupt input pin (3)	-	-	77	
EINT14_3	External interrupt input pin (3)	-	-	78	
EINT15_3	External interrupt input pin (3)	-	-	79	
EINT16_3	External interrupt input pin (3)	-	-	80	
EINT17_3	External interrupt input pin (3)	-	71	83	
EINT18_3	External interrupt input pin (3)	-	76	88	
EINT19_3	External interrupt input pin (3)	-	80	92	
EINT20_3	External interrupt input pin (3)	-	-	96	
EINT21_3	External interrupt input pin (3)	-	-	97	

Port Name	Description	Package Pin Number			Remark
		TEQFP 144	TEQFP 176	TEQFP 208	
EINT22_3	External interrupt input pin (3)	-	-	99	
EINT23_3	External interrupt input pin (3)	-	-	100	
EINT0_4	External interrupt input pin (4)	-	99	115	
EINT1_4	External interrupt input pin (4)	-	-	116	
EINT2_4	External interrupt input pin (4)	-	107	124	
EINT3_4	External interrupt input pin (4)	-	108	125	
EINT4_4	External interrupt input pin (4)	-	110	127	
EINT5_4	External interrupt input pin (4)	-	-	130	
EINT6_4	External interrupt input pin (4)	-	-	131	
EINT7_4	External interrupt input pin (4)	-	-	137	
EINT8_4	External interrupt input pin (4)	-	-	138	
EINT9_4	External interrupt input pin (4)	93	117	139	
EINT10_4	External interrupt input pin (4)	-	-	141	
EINT11_4	External interrupt input pin (4)	101	125	149	
EINT12_4	External interrupt input pin (4)	103	127	151	
EINT13_4	External interrupt input pin (4)	105	129	153	
EINT14_4	External interrupt input pin (4)	107	131	155	
EINT15_4	External interrupt input pin (4)	110	134	158	
EINT16_4	External interrupt input pin (4)	-	-	159	
EINT17_4	External interrupt input pin (4)	111	135	160	
EINT18_4	External interrupt input pin (4)	112	136	161	
EINT19_4	External interrupt input pin (4)	-	-	163	
EINT20_4	External interrupt input pin (4)	114	138	164	
EINT21_4	External interrupt input pin (4)	115	139	165	
EINT22_4	External interrupt input pin (4)	116	140	166	
EINT23_4	External interrupt input pin (4)	-	-	167	
EINT0_5	External interrupt input pin (5)	120	144	171	
EINT1_5	External interrupt input pin (5)	-	-	172	
EINT2_5	External interrupt input pin (5)	121	145	173	
EINT3_5	External interrupt input pin (5)	122	146	174	
EINT4_5	External interrupt input pin (5)	123	147	175	
EINT5_5	External interrupt input pin (5)	-	-	176	
EINT6_5	External interrupt input pin (5)	125	149	178	
EINT7_5	External interrupt input pin (5)	126	150	179	
EINT8_5	External interrupt input pin (5)	-	-	180	
EINT9_5	External interrupt input pin (5)	127	151	181	
EINT10_5	External interrupt input pin (5)	-	-	185	
EINT11_5	External interrupt input pin (5)	-	154	186	
EINT12_5	External interrupt input pin (5)	-	155	187	
EINT13_5	External interrupt input pin (5)	-	156	188	
EINT14_5	External interrupt input pin (5)	-	157	189	
EINT15_5	External interrupt input pin (5)	130	158	190	
EINT16_5	External interrupt input pin (5)	-	163	195	
EINT17_5	External interrupt input pin (5)	-	164	196	
EINT18_5	External interrupt input pin (5)	-	165	197	
EINT19_5	External interrupt input pin (5)	134	166	198	
EINT20_5	External interrupt input pin (5)	135	167	199	
EINT21_5	External interrupt input pin (5)	136	168	200	
EINT22_5	External interrupt input pin (5)	138	170	202	

Port Name	Description	Package Pin Number			Remark
		TEQFP 144	TEQFP 176	TEQFP 208	
EINT23_5	External interrupt input pin (5)	139	171	203	
EINT0_6	External interrupt input pin (6)	140	172	204	
EINT1_6	External interrupt input pin (6)	141	173	205	
EINT2_6	External interrupt input pin (6)	142	174	206	
EINT3_6	External interrupt input pin (6)	143	175	207	
SCS00_0	Multi-function serial ch.0 chip select 0 I/O pin (0)	64	78	90	
SCS10_0	Multi-function serial ch.1 chip select 0 I/O pin (0)	6	6	9	
SCS11_0	Multi-function serial ch.1 chip select 1 output pin (0)	7	7	10	
SCS12_0	Multi-function serial ch.1 chip select 2 output pin (0)	8	8	11	
SCS13_0	Multi-function serial ch.1 chip select 3 output pin (0)	9	9	12	
SCS20_0	Multi-function serial ch.2 chip select 0 I/O pin (0)	41	49	57	
SCS21_0	Multi-function serial ch.2 chip select 1 output pin (0)	42	50	58	
SCS22_0	Multi-function serial ch.2 chip select 2 output pin (0)	44	52	60	
SCS23_0	Multi-function serial ch.2 chip select 3 output pin (0)	47	55	63	
SCS30_0	Multi-function serial ch.3 chip select 0 I/O pin (0)	51	59	67	
SCS31_0	Multi-function serial ch.3 chip select 1 output pin (0)	54	62	70	
SCS32_0	Multi-function serial ch.3 chip select 2 output pin (0)	55	63	71	
SCS33_0	Multi-function serial ch.3 chip select 3 output pin (0)	56	64	72	
SCS40_0	Multi-function serial ch.4 chip select 0 I/O pin (0)	140	172	204	
SCS41_0	Multi-function serial ch.4 chip select 1 output pin (0)	141	173	205	
SCS42_0	Multi-function serial ch.4 chip select 2 output pin (0)	142	174	206	
SCS43_0	Multi-function serial ch.4 chip select 3 output pin (0)	143	175	207	
SCS80_0	Multi-function serial ch.8 chip select 0 I/O pin (0)	105	129	153	
SCS90_0	Multi-function serial ch.9 chip select 0 I/O pin (0)	111	135	160	
SCS91_0	Multi-function serial ch.9 chip select 1 output pin (0)	112	136	161	
SCS100_0	Multi-function serial ch.10 chip select 0 I/O pin (0)	116	140	166	
SCS110_0	Multi-function serial ch.11 chip select 0 I/O pin (0)	122	146	174	
SCS111_0	Multi-function serial ch.11 chip select 1 output pin (0)	123	147	175	
SCS120_0	Multi-function serial ch.12 chip select 0 I/O pin (0)	127	151	181	
SCS160_0	Multi-function serial ch.16 chip select 0 I/O pin (0)	70	86	102	
SCS161_0	Multi-function serial ch.16 chip select 1 output pin (0)	71	87	103	
SCS170_0	Multi-function serial ch.17 chip select 0 I/O pin (0)	100	124	148	
SCS171_0	Multi-function serial ch.17 chip select 1 output pin (0)	101	125	149	
SCS00_1	Multi-function serial ch.0 chip select 0 I/O pin (1)	9	9	12	
SCS10_1	Multi-function serial ch.1 chip select 0 I/O pin (1)	-	22	28	
SCS11_1	Multi-function serial ch.1 chip select 1 output pin (1)	-	23	29	
SCS12_1	Multi-function serial ch.1 chip select 2 output pin (1)	-	24	32	
SCS13_1	Multi-function serial ch.1 chip select 3 output pin (1)	-	25	33	
SCS20_1	Multi-function serial ch.2 chip select 0 I/O pin (1)	-	155	187	
SCS21_1	Multi-function serial ch.2 chip select 1 output pin (1)	-	156	188	
SCS22_1	Multi-function serial ch.2 chip select 2 output pin (1)	-	157	189	
SCS23_1	Multi-function serial ch.2 chip select 3 output pin (1)	130	158	190	
SCS30_1	Multi-function serial ch.3 chip select 0 I/O pin (1)	-	165	197	
SCS31_1	Multi-function serial ch.3 chip select 1 output pin (1)	134	166	198	
SCS32_1	Multi-function serial ch.3 chip select 2 output pin (1)	135	167	199	
SCS33_1	Multi-function serial ch.3 chip select 3 output pin (1)	136	168	200	
SCS40_1	Multi-function serial ch.4 chip select 0 I/O pin (1)	20	27	35	
SCS41_1	Multi-function serial ch.4 chip select 1 output pin (1)	21	28	36	
SCS42_1	Multi-function serial ch.4 chip select 2 output pin (1)	-	29	37	

Port Name	Description	Package Pin Number			Remark
		TEQFP 144	TEQFP 176	TEQFP 208	
SCS43_1	Multi-function serial ch.4 chip select 3 output pin (1)	22	30	38	
SCS80_1	Multi-function serial ch.8 chip select 0 I/O pin (1)	-	72	84	
SCS90_1	Multi-function serial ch.9 chip select 0 I/O pin (1)	-	108	125	
SCS91_1	Multi-function serial ch.9 chip select 1 output pin (1)	-	109	126	
SCS100_1	Multi-function serial ch.10 chip select 0 I/O pin (1)	-	80	92	
SCS120_1	Multi-function serial ch.12 chip select 0 I/O pin (1)	-	110	127	
SCS160_1	Multi-function serial ch.16 chip select 0 I/O pin (1)	-	-	141	
SCS161_1	Multi-function serial ch.16 chip select 1 output pin (1)	-	-	140	
SCS170_1	Multi-function serial ch.17 chip select 0 I/O pin (1)	-	-	15	
SCS171_1	Multi-function serial ch.17 chip select 1 output pin (1)	12	12	18	
SCS80_2	Multi-function serial ch.8 chip select 0 I/O pin (2)	50	58	66	
SCS90_2	Multi-function serial ch.9 chip select 0 I/O pin (2)	41	49	57	
SCS91_2	Multi-function serial ch.9 chip select 1 output pin (2)	42	50	58	
SCK0_0	Multi-function serial ch.0 clock I/O pin (0)	62	74	86	
SCK1_0	Multi-function serial ch.1 clock I/O pin (0)	4	4	4	
SCK2_0	Multi-function serial ch.2 clock I/O pin (0)	39	47	55	
SCK3_0	Multi-function serial ch.3 clock I/O pin (0)	49	57	65	
SCK4_0	Multi-function serial ch.4 clock I/O pin (0)	138	170	202	
SCK8_0	Multi-function serial ch.8 clock I/O pin (0)	103	127	151	
SCK9_0	Multi-function serial ch.9 clock I/O pin (0)	107	131	155	
SCK10_0	Multi-function serial ch.10 clock I/O pin (0)	114	138	164	
SCK11_0	Multi-function serial ch.11 clock I/O pin (0)	120	144	171	
SCK12_0	Multi-function serial ch.12 clock I/O pin (0)	125	149	178	
SCK16_0	Multi-function serial ch.16 clock I/O pin (0)	67	83	95	
SCK17_0	Multi-function serial ch.17 clock I/O pin (0)	88	112	129	
SCK0_1	Multi-function serial ch.0 clock I/O pin (1)	8	8	11	
SCK1_1	Multi-function serial ch.1 clock I/O pin (1)	-	20	26	
SCK2_1	Multi-function serial ch.2 clock I/O pin (1)	-	-	185	
SCK3_1	Multi-function serial ch.3 clock I/O pin (1)	-	163	195	
SCK4_1	Multi-function serial ch.4 clock I/O pin (1)	19	26	34	
SCK8_1	Multi-function serial ch.8 clock I/O pin (1)	-	70	82	
SCK9_1	Multi-function serial ch.9 clock I/O pin (1)	-	106	123	
SCK10_1	Multi-function serial ch.10 clock I/O pin (1)	-	76	88	
SCK12_1	Multi-function serial ch.12 clock I/O pin (1)	88	112	129	
SCK16_1	Multi-function serial ch.16 clock I/O pin (1)	-	-	138	
SCK17_1	Multi-function serial ch.17 clock I/O pin (1)	-	-	16	
SCK8_2	Multi-function serial ch.8 clock I/O pin (2)	48	56	64	
SCK9_2	Multi-function serial ch.9 clock I/O pin (2)	40	48	56	
SIN0_0	Multi-function serial ch.0 serial data input pin (0)	61	73	85	
SIN1_0	Multi-function serial ch.1 serial data input pin (0)	3	3	3	
SIN2_0	Multi-function serial ch.2 serial data input pin (0)	38	46	54	
SIN3_0	Multi-function serial ch.3 serial data input pin (0)	48	56	64	
SIN4_0	Multi-function serial ch.4 serial data input pin (0)	137	169	201	
SIN8_0	Multi-function serial ch.8 serial data input pin (0)	102	126	150	
SIN9_0	Multi-function serial ch.9 serial data input pin (0)	106	130	154	
SIN10_0	Multi-function serial ch.10 serial data input pin (0)	113	137	162	
SIN11_0	Multi-function serial ch.11 serial data input pin (0)	117	141	168	
SIN12_0	Multi-function serial ch.12 serial data input pin (0)	124	148	177	
SIN16_0	Multi-function serial ch.16 serial data input pin (0)	66	82	94	

Port Name	Description	Package Pin Number			Remark
		TEQFP 144	TEQFP 176	TEQFP 208	
SIN17_0	Multi-function serial ch.17 serial data input pin (0)	87	111	128	
SIN0_1	Multi-function serial ch.0 serial data input pin (1)	6	6	9	
SIN1_1	Multi-function serial ch.1 serial data input pin (1)	-	19	25	
SIN2_1	Multi-function serial ch.2 serial data input pin (1)	-	-	184	
SIN3_1	Multi-function serial ch.3 serial data input pin (1)	-	162	194	
SIN4_1	Multi-function serial ch.4 serial data input pin (1)	-	24	32	
SIN8_1	Multi-function serial ch.8 serial data input pin (1)	-	69	81	
SIN9_1	Multi-function serial ch.9 serial data input pin (1)	-	105	122	
SIN10_1	Multi-function serial ch.10 serial data input pin (1)	-	75	87	
SIN12_1	Multi-function serial ch.12 serial data input pin (1)	-	-	131	
SIN16_1	Multi-function serial ch.16 serial data input pin (1)	-	-	136	
SIN17_1	Multi-function serial ch.17 serial data input pin (1)	11	11	14	
SIN8_2	Multi-function serial ch.8 serial data input pin (2)	47	55	63	
SIN9_2	Multi-function serial ch.9 serial data input pin (2)	38	46	54	
SOT0_0	Multi-function serial ch.0 serial data output pin (0)	63	77	89	
SOT1_0	Multi-function serial ch.1 serial data output pin (0)	5	5	5	
SOT2_0	Multi-function serial ch.2 serial data output pin (0)	40	48	56	
SOT3_0	Multi-function serial ch.3 serial data output pin (0)	50	58	66	
SOT4_0	Multi-function serial ch.4 serial data output pin (0)	139	171	203	
SOT8_0	Multi-function serial ch.8 serial data output pin (0)	104	128	152	
SOT9_0	Multi-function serial ch.9 serial data output pin (0)	110	134	158	
SOT10_0	Multi-function serial ch.10 serial data output pin (0)	115	139	165	
SOT11_0	Multi-function serial ch.11 serial data output pin (0)	121	145	173	
SOT12_0	Multi-function serial ch.12 serial data output pin (0)	126	150	179	
SOT16_0	Multi-function serial ch.16 serial data output pin (0)	68	84	98	
SOT17_0	Multi-function serial ch.17 serial data output pin (0)	93	117	139	
SOT0_1	Multi-function serial ch.0 serial data output pin (1)	7	7	10	
SOT1_1	Multi-function serial ch.1 serial data output pin (1)	-	21	27	
SOT2_1	Multi-function serial ch.2 serial data output pin (1)	-	154	186	
SOT3_1	Multi-function serial ch.3 serial data output pin (1)	-	164	196	
SOT4_1	Multi-function serial ch.4 serial data output pin (1)	-	25	33	
SOT8_1	Multi-function serial ch.8 serial data output pin (1)	-	71	83	
SOT9_1	Multi-function serial ch.9 serial data output pin (1)	-	107	124	
SOT10_1	Multi-function serial ch.10 serial data output pin (1)	-	79	91	
SOT12_1	Multi-function serial ch.12 serial data output pin (1)	-	-	130	
SOT16_1	Multi-function serial ch.16 serial data output pin (1)	-	-	137	
SOT17_1	Multi-function serial ch.17 serial data output pin (1)	-	-	17	
SOT8_2	Multi-function serial ch.8 serial data output pin (2)	49	57	65	
SOT9_2	Multi-function serial ch.9 serial data output pin (2)	39	47	55	
SCL0	I <sup>2</sup> C ch.0 clock I/O pin	62	74	86	
SCL1	I <sup>2</sup> C ch.1 clock I/O pin	4	4	4	
SCL4	I <sup>2</sup> C ch.4 clock I/O pin	138	170	202	
SCL8	I <sup>2</sup> C ch.8 clock I/O pin	103	127	151	
SCL9	I <sup>2</sup> C ch.9 clock I/O pin	107	131	155	
SCL10	I <sup>2</sup> C ch.10 clock I/O pin	114	138	164	
SCL11	I <sup>2</sup> C ch.11 clock I/O pin	120	144	171	
SCL12	I <sup>2</sup> C ch.12 clock I/O pin	125	149	178	
SCL16	I <sup>2</sup> C ch.16 clock I/O pin	67	83	95	
SCL17	I <sup>2</sup> C ch.17 clock I/O pin	88	112	129	

Port Name	Description	Package Pin Number			Remark
		TEQFP 144	TEQFP 176	TEQFP 208	
SDA0	I <sup>2</sup> C ch.0 serial data I/O pin	63	77	89	
SDA1	I <sup>2</sup> C ch.1 serial data I/O pin	5	5	5	
SDA4	I <sup>2</sup> C ch.4 serial data I/O pin	139	171	203	
SDA8	I <sup>2</sup> C ch.8 serial data I/O pin	104	128	152	
SDA9	I <sup>2</sup> C ch.9 serial data I/O pin	110	134	158	
SDA10	I <sup>2</sup> C ch.10 serial data I/O pin	115	139	165	
SDA11	I <sup>2</sup> C ch.11 serial data I/O pin	121	145	173	
SDA12	I <sup>2</sup> C ch.12 serial data I/O pin	126	150	179	
SDA16	I <sup>2</sup> C ch.16 serial data I/O pin	68	84	98	
SDA17	I <sup>2</sup> C ch.17 serial data I/O pin	93	117	139	
PPG0_TOUT0_0	Base timer 0 output pin (0)	61	73	85	
PPG0_TOUT2_0	Base timer 1 output pin (0)	62	74	86	
PPG1_TOUT0_0	Base timer 2 output pin (0)	63	77	89	
PPG1_TOUT2_0	Base timer 3 output pin (0)	64	78	90	
PPG2_TOUT0_0	Base timer 4 output pin (0)	65	81	93	
PPG2_TOUT2_0	Base timer 5 output pin (0)	66	82	94	
PPG3_TOUT0_0	Base timer 6 output pin (0)	67	83	95	
PPG3_TOUT2_0	Base timer 7 output pin (0)	68	84	98	
PPG4_TOUT0_0	Base timer 8 output pin (0)	70	86	102	
PPG4_TOUT2_0	Base timer 9 output pin (0)	71	87	103	
PPG5_TOUT0_0	Base timer 10 output pin (0)	87	111	128	
PPG5_TOUT2_0	Base timer 11 output pin (0)	88	112	129	
PPG6_TOUT0_0	Base timer 12 output pin (0)	100	124	148	
PPG6_TOUT2_0	Base timer 13 output pin (0)	101	125	149	
PPG7_TOUT0_0	Base timer 14 output pin (0)	102	126	150	
PPG7_TOUT2_0	Base timer 15 output pin (0)	103	127	151	
PPG8_TOUT0_0	Base timer 16 output pin (0)	104	128	152	
PPG8_TOUT2_0	Base timer 17 output pin (0)	105	129	153	
PPG9_TOUT0_0	Base timer 18 output pin (0)	106	130	154	
PPG9_TOUT2_0	Base timer 19 output pin (0)	107	131	155	
PPG10_TOUT0_0	Base timer 20 output pin (0)	110	134	158	
PPG10_TOUT2_0	Base timer 21 output pin (0)	111	135	160	
PPG11_TOUT0_0	Base timer 22 output pin (0)	112	136	161	
PPG11_TOUT2_0	Base timer 23 output pin (0)	113	137	162	
PPG12_TOUT0_0	Base timer 24 output pin (0)	115	139	165	
PPG12_TOUT2_0	Base timer 25 output pin (0)	116	140	166	
PPG13_TOUT0_0	Base timer 26 output pin (0)	117	141	168	
PPG13_TOUT2_0	Base timer 27 output pin (0)	120	144	171	
PPG14_TOUT0_0	Base timer 28 output pin (0)	121	145	173	
PPG14_TOUT2_0	Base timer 29 output pin (0)	122	146	174	
PPG15_TOUT0_0	Base timer 30 output pin (0)	123	147	175	
PPG15_TOUT2_0	Base timer 31 output pin (0)	124	148	177	
PPG0_TOUT0_1	Base timer 0 output pin (1)	8	8	11	
PPG0_TOUT2_1	Base timer 1 output pin (1)	9	9	12	
PPG1_TOUT0_1	Base timer 2 output pin (1)	10	10	13	
PPG1_TOUT2_1	Base timer 3 output pin (1)	11	11	14	
PPG2_TOUT0_1	Base timer 4 output pin (1)	12	12	18	
PPG2_TOUT2_1	Base timer 5 output pin (1)	13	13	19	
PPG3_TOUT0_1	Base timer 6 output pin (1)	14	14	20	

Port Name	Description	Package Pin Number			Remark
		TEQFP 144	TEQFP 176	TEQFP 208	
PPG3_TOUT2_1	Base timer 7 output pin (1)	15	15	21	
PPG4_TOUT0_1	Base timer 8 output pin (1)	-	19	25	
PPG4_TOUT2_1	Base timer 9 output pin (1)	-	20	26	
PPG5_TOUT0_1	Base timer 10 output pin (1)	-	21	27	
PPG5_TOUT2_1	Base timer 11 output pin (1)	-	22	28	
PPG6_TOUT0_1	Base timer 12 output pin (1)	-	69	81	
PPG6_TOUT2_1	Base timer 13 output pin (1)	-	70	82	
PPG7_TOUT0_1	Base timer 14 output pin (1)	-	71	83	
PPG7_TOUT2_1	Base timer 15 output pin (1)	-	72	84	
PPG8_TOUT0_1	Base timer 16 output pin (1)	-	75	87	
PPG8_TOUT2_1	Base timer 17 output pin (1)	-	76	88	
PPG9_TOUT0_1	Base timer 18 output pin (1)	-	79	91	
PPG9_TOUT2_1	Base timer 19 output pin (1)	-	80	92	
PPG10_TOUT0_1	Base timer 20 output pin (1)	-	98	114	
PPG10_TOUT2_1	Base timer 21 output pin (1)	-	99	115	
PPG11_TOUT0_1	Base timer 22 output pin (1)	-	105	122	
PPG11_TOUT2_1	Base timer 23 output pin (1)	-	106	123	
PPG12_TOUT0_1	Base timer 24 output pin (1)	-	154	186	
PPG12_TOUT2_1	Base timer 25 output pin (1)	-	155	187	
PPG13_TOUT0_1	Base timer 26 output pin (1)	-	156	188	
PPG13_TOUT2_1	Base timer 27 output pin (1)	-	157	189	
PPG14_TOUT0_1	Base timer 28 output pin (1)	130	158	190	
PPG14_TOUT2_1	Base timer 29 output pin (1)	-	162	194	
PPG15_TOUT0_1	Base timer 30 output pin (1)	-	163	195	
PPG15_TOUT2_1	Base timer 31 output pin (1)	-	164	196	
PPG0/1/2/3/4/5_TIN1_0	Base timer 0/2/4/6/8/10 input pin (0)	93	117	139	
PPG6/7/8/9/10/11_TIN1_0	Base timer 12/14/16/18/20/22 input pin (0)	114	138	164	
PPG12/13/14/15_TIN1_0	Base timer 24/26/28/30 input pin (0)	125	149	178	
PPG0/1/2/3/4/5_TIN1_1	Base timer 0/2/4/6/8/10 input pin (1)	-	23	29	
PPG6/7/8/9/10/11_TIN1_1	Base timer 12/14/16/18/20/22 input pin (1)	-	107	124	
PPG12/13/14/15_TIN1_1	Base timer 24/26/28/30 input pin (1)	-	165	197	
WOT	RTC overflow output pin	93	117	139	
PWM1M0	SMC ch.0 output pin	101	125	149	
PWM1M1	SMC ch.1 output pin	105	129	153	
PWM1M2	SMC ch.2 output pin	111	135	160	
PWM1M3	SMC ch.3 output pin	115	139	165	
PWM1M4	SMC ch.4 output pin	121	145	173	
PWM1M5	SMC ch.5 output pin	125	149	178	
PWM1P0	SMC ch.0 output pin	100	124	148	
PWM1P1	SMC ch.1 output pin	104	128	152	
PWM1P2	SMC ch.2 output pin	110	134	158	
PWM1P3	SMC ch.3 output pin	114	138	164	
PWM1P4	SMC ch.4 output pin	120	144	171	
PWM1P5	SMC ch.5 output pin	124	148	177	
PWM2M0	SMC ch.0 output pin	103	127	151	
PWM2M1	SMC ch.1 output pin	107	131	155	
PWM2M2	SMC ch.2 output pin	113	137	162	
PWM2M3	SMC ch.3 output pin	117	141	168	
PWM2M4	SMC ch.4 output pin	123	147	175	

Port Name	Description	Package Pin Number			Remark
		TEQFP 144	TEQFP 176	TEQFP 208	
PWM2M5	SMC ch.5 output pin	127	151	181	
PWM2P0	SMC ch.0 output pin	102	126	150	
PWM2P1	SMC ch.1 output pin	106	130	154	
PWM2P2	SMC ch.2 output pin	112	136	161	
PWM2P3	SMC ch.3 output pin	116	140	166	
PWM2P4	SMC ch.4 output pin	122	146	174	
PWM2P5	SMC ch.5 output pin	126	150	179	
OCU0_OTD0_0	Output compare 0 ch.0 output pin (0)	61	73	85	
OCU0_OTD1_0	Output compare 0 ch.1 output pin (0)	62	74	86	
OCU1_OTD0_0	Output compare 1 ch.0 output pin (0)	65	81	93	
OCU1_OTD1_0	Output compare 1 ch.1 output pin (0)	66	82	94	
OCU2_OTD0_0	Output compare 2 ch.0 output pin (0)	67	83	95	
OCU2_OTD1_0	Output compare 2 ch.1 output pin (0)	68	84	98	
OCU8_OTD0_0	Output compare 8 ch.0 output pin (0)	70	86	102	
OCU8_OTD1_0	Output compare 8 ch.1 output pin (0)	71	87	103	
OCU9_OTD0_0	Output compare 9 ch.0 output pin (0)	81	97	113	
OCU9_OTD1_0	Output compare 9 ch.1 output pin (0)	87	111	128	
OCU10_OTD0_0	Output compare 10 ch.0 output pin (0)	88	112	129	
OCU10_OTD1_0	Output compare 10 ch.1 output pin (0)	93	117	139	
OCU0_OTD0_1	Output compare 0 ch.0 output pin (1)	-	69	81	
OCU0_OTD1_1	Output compare 0 ch.1 output pin (1)	-	70	82	
OCU1_OTD0_1	Output compare 1 ch.0 output pin (1)	-	71	83	
OCU1_OTD1_1	Output compare 1 ch.1 output pin (1)	-	72	84	
OCU2_OTD0_1	Output compare 2 ch.0 output pin (1)	-	75	87	
OCU2_OTD1_1	Output compare 2 ch.1 output pin (1)	-	76	88	
OCU8_OTD0_1	Output compare 8 ch.0 output pin (1)	-	79	91	
OCU8_OTD1_1	Output compare 8 ch.1 output pin (1)	-	80	92	
OCU9_OTD0_1	Output compare 9 ch.0 output pin (1)	-	98	114	
OCU9_OTD1_1	Output compare 9 ch.1 output pin (1)	-	99	115	
OCU10_OTD0_1	Output compare 10 ch.0 output pin (1)	-	105	122	
OCU10_OTD1_1	Output compare 10 ch.1 output pin (1)	-	106	123	
ICU0_IN0_0	Input Capture 0 ch.0 input pin (0)	61	73	85	
ICU0_IN1_0	Input Capture 0 ch.1 input pin (0)	62	74	86	
ICU1_IN0_0	Input Capture 1 ch.0 input pin (0)	63	77	89	
ICU1_IN1_0	Input Capture 1 ch.1 input pin (0)	64	78	90	
ICU2_IN0_0	Input Capture 2 ch.0 input pin (0)	65	81	93	
ICU2_IN1_0	Input Capture 2 ch.1 input pin (0)	66	82	94	
ICU8_IN0_0	Input Capture 8 ch.0 input pin (0)	67	83	95	
ICU8_IN1_0	Input Capture 8 ch.1 input pin (0)	68	84	98	
ICU9_IN0_0	Input Capture 9 ch.0 input pin (0)	70	86	102	
ICU9_IN1_0	Input Capture 9 ch.1 input pin (0)	71	87	103	
ICU10_IN0_0	Input Capture 10 ch.0 input pin (0)	87	111	128	
ICU10_IN1_0	Input Capture 10 ch.1 input pin (0)	88	112	129	
ICU0_IN0_1	Input Capture 0 ch.0 input pin (1)	-	69	81	
ICU0_IN1_1	Input Capture 0 ch.1 input pin (1)	-	70	82	
ICU1_IN0_1	Input Capture 1 ch.0 input pin (1)	-	71	83	
ICU1_IN1_1	Input Capture 1 ch.1 input pin (1)	-	72	84	
ICU2_IN0_1	Input Capture 2 ch.0 input pin (1)	-	75	87	
ICU2_IN1_1	Input Capture 2 ch.1 input pin (1)	-	76	88	



Port Name	Description	Package Pin Number			Remark
		TEQFP 144	TEQFP 176	TEQFP 208	
ICU8_IN0_1	Input Capture 8 ch.0 input pin (1)	-	79	91	
ICU8_IN1_1	Input Capture 8 ch.1 input pin (1)	-	80	92	
ICU9_IN0_1	Input Capture 9 ch.0 input pin (1)	-	98	114	
ICU9_IN1_1	Input Capture 9 ch.1 input pin (1)	-	99	115	
ICU10_IN0_1	Input Capture 10 ch.0 input pin (1)	-	105	122	
ICU10_IN1_1	Input Capture 10 ch.1 input pin (1)	-	106	123	
SGA0_0	Sound generator ch.0 SGA output pin (0)	63	77	89	
SGA1_0	Sound generator ch.1 SGA output pin (0)	65	81	93	
SGA2_0	Sound generator ch.2 SGA output pin (0)	67	83	95	
SGA3_0	Sound generator ch.3 SGA output pin (0)	81	97	113	
SGA4_0	Sound generator ch.4 SGA output pin (0)	88	112	129	
SGA0_1	Sound generator ch.0 SGA output pin (1)	-	69	81	
SGA1_1	Sound generator ch.1 SGA output pin (1)	-	71	83	
SGA2_1	Sound generator ch.2 SGA output pin (1)	-	75	87	
SGA3_1	Sound generator ch.3 SGA output pin (1)	-	79	91	
SGA4_1	Sound generator ch.4 SGA output pin (1)	-	98	114	
SGO0_0	Sound generator ch.0 SGO output pin (0)	64	78	90	
SGO1_0	Sound generator ch.1 SGO output pin (0)	66	82	94	
SGO2_0	Sound generator ch.2 SGO output pin (0)	68	84	98	
SGO3_0	Sound generator ch.3 SGO output pin (0)	87	111	128	
SGO4_0	Sound generator ch.4 SGO output pin (0)	93	117	139	
SGO0_1	Sound generator ch.0 SGO output pin (1)	-	70	82	
SGO1_1	Sound generator ch.1 SGO output pin (1)	-	72	84	
SGO2_1	Sound generator ch.2 SGO output pin (1)	-	76	88	
SGO3_1	Sound generator ch.3 SGO output pin (1)	-	80	92	
SGO4_1	Sound generator ch.4 SGO output pin (1)	-	99	115	
AN0 (AL0)	PCM PWM ch.0 output pin	63	77	89	
AN1 (AL1)	PCM PWM ch.1 output pin	67	83	95	
AP0 (AH0)	PCM PWM ch.0 output pin	64	78	90	
AP1 (AH1)	PCM PWM ch.1 output pin	68	84	98	
BN0 (BL0)	PCM PWM ch.0 output pin	61	73	85	
BN1 (BL1)	PCM PWM ch.1 output pin	65	81	93	
BP0 (BH0)	PCM PWM ch.0 output pin	62	74	86	
BP1 (BH1)	PCM PWM ch.1 output pin	66	82	94	
I2S0_ECLK_0	I2S external clock ch.0 input pin (0)	12	12	18	
I2S0_ECLK_1	I2S external clock ch.0 input pin (1)	-	154	186	
I2S1_ECLK_0	I2S external clock ch.1 input pin (0)	8	8	11	
I2S0_SCK_0	I2S continuous serial clock ch.0 I/O pin (0)	15	15	21	
I2S0_SCK_1	I2S continuous serial clock ch.0 I/O pin (1)	-	157	189	
I2S1_SCK_0	I2S continuous serial clock ch.1 I/O pin (0)	11	11	14	
I2S0_SD_0	I2S serial data ch.0 I/O pin (0)	13	13	19	
I2S0_SD_1	I2S serial data ch.0 I/O pin (1)	-	155	187	
I2S1_SD_0	I2S serial data ch.1 I/O pin (0)	9	9	12	
I2S0_WS_0	I2S word select ch.0 I/O pin (0)	14	14	20	
I2S0_WS_1	I2S word select ch.0 I/O pin (1)	-	156	188	
I2S1_WS_0	I2S word select ch.1 I/O pin (0)	10	10	13	
C_L	Audio DAC external capacity connection output pin (L)	34	42	50	
C_R	Audio DAC external capacity connection output pin (R)	30	38	46	

Port Name	Description	Package Pin Number			Remark
		TEQFP 144	TEQFP 176	TEQFP 208	
DAC_L	Audio DAC output pin (L)	33	41	49	
DAC_R	Audio DAC output pin (R)	29	37	45	
FRT0/1/2/3_TEXT	Free-run timer ch.0/1/2/3 clock input pin	61	73	85	
FRT4/8/9/10_TEXT	Free-run timer ch.4/8/9/10 clock input pin	62	74	86	
TIN0_0	Reload timer ch.0 event input pin (0)	61	73	85	
TIN1_0	Reload timer ch.1 event input pin (0)	63	77	89	
TIN16_0	Reload timer ch.16 event input pin (0)	65	81	93	
TIN17_0	Reload timer ch.17 event input pin (0)	70	86	102	
TIN48_0	Reload timer ch.48 event input pin (0)	81	97	113	
TIN49_0	Reload timer ch.49 event input pin (0)	88	112	129	
TIN0_1	Reload timer ch.0 event input pin (0)	-	69	81	
TIN1_1	Reload timer ch.1 event input pin (1)	-	71	83	
TIN16_1	Reload timer ch.16 event input pin (1)	-	75	87	
TIN17_1	Reload timer ch.17 event input pin (1)	-	79	91	
TIN48_1	Reload timer ch.48 event input pin (1)	-	98	114	
TIN49_1	Reload timer ch.49 event input pin (1)	-	107	124	
TOT0_0	Reload timer ch.0 output pin (0)	62	74	86	
TOT1_0	Reload timer ch.1 output pin (0)	64	78	90	
TOT16_0	Reload timer ch.16 output pin (0)	66	82	94	
TOT17_0	Reload timer ch.17 output pin (0)	71	87	103	
TOT48_0	Reload timer ch.48 output pin (0)	87	111	128	
TOT49_0	Reload timer ch.49 output pin (0)	93	117	139	
TOT0_1	Reload timer ch.0 output pin (1)	-	70	82	
TOT1_1	Reload timer ch.1 output pin (1)	-	72	84	
TOT16_1	Reload timer ch.16 output pin (1)	-	76	88	
TOT17_1	Reload timer ch.17 output pin (1)	-	80	92	
TOT48_1	Reload timer ch.48 output pin (1)	-	99	115	
TOT49_1	Reload timer ch.49 output pin (1)	-	108	125	
AIN8	Up/Down counter AIN input pin ch.8	61	73	85	
AIN9	Up/Down counter AIN input pin ch.9	64	78	90	
BIN8	Up/Down counter BIN input pin ch.8	62	74	86	
BIN9	Up/Down counter BIN input pin ch.9	65	81	93	
ZIN8	Up/Down counter ZIN input pin ch.8	63	77	89	
ZIN9	Up/Down counter ZIN input pin ch.9	66	82	94	
RXD0_0	Ethernet pin (0)	47	55	63	
RXD1_0	Ethernet pin (0)	48	56	64	
RXD2_0	Ethernet pin (0)	49	57	65	
RXD3_0	Ethernet pin (0)	50	58	66	
TXD0_0	Ethernet pin (0)	39	47	55	
TXD1_0	Ethernet pin (0)	40	48	56	
TXD2_0	Ethernet pin (0)	41	49	57	
TXD3_0	Ethernet pin (0)	42	50	58	
COL_0	Ethernet pin (0)	55	63	71	
CRS_0	Ethernet pin (0)	56	64	72	
RXER_0	Ethernet pin (0)	23	31	39	
RXDV_0	Ethernet pin (0)	24	32	40	
RXCLK_0	Ethernet pin (0)	22	30	38	
TXER_0	Ethernet pin (0)	44	52	60	
TXEN_0	Ethernet pin (0)	38	46	54	

Port Name	Description	Package Pin Number			Remark
		TEQFP 144	TEQFP 176	TEQFP 208	
TXCLK_0	Ethernet pin (0)	25	33	41	
MDC_0	Ethernet pin (0)	54	62	70	
MDIO_0	Ethernet pin (0)	51	59	67	
RXD0_1	Ethernet pin (1)	-	23	29	
RXD1_1	Ethernet pin (1)	-	-	30	
RXD2_1	Ethernet pin (1)	-	-	31	
RXD3_1	Ethernet pin (1)	-	24	32	
TXD0_1	Ethernet pin (1)	-	-	17	
TXD1_1	Ethernet pin (1)	-	19	25	
TXD2_1	Ethernet pin (1)	-	20	26	
TXD3_1	Ethernet pin (1)	-	21	27	
COL_1	Ethernet pin (1)	24	32	40	
CRS_1	Ethernet pin (1)	25	33	41	
RXER_1	Ethernet pin (1)	-	-	7	
RXDV_1	Ethernet pin (1)	-	-	8	
RXCLK_1	Ethernet pin (1)	-	-	6	
TXER_1	Ethernet pin (1)	-	22	28	
TXEN_1	Ethernet pin (1)	-	-	16	
TXCLK_1	Ethernet pin (1)	-	-	15	
MDC_1	Ethernet pin (1)	23	31	39	
MDIO_1	Ethernet pin (1)	-	25	33	
MLBCLK	MediaLB pin	54	62	70	
MLBDAT	MediaLB pin	56	64	72	
MLBSIG	MediaLB pin	55	63	71	
M_SCLK0	MCU HS-SPI clock output pin	44	52	60	
M_SDAT0_0	MCU HS-SPI0 data 0 I/O pin	38	46	54	
M_SDAT0_1	MCU HS-SPI0 data 1 I/O pin	40	48	56	
M_SDAT0_2	MCU HS-SPI0 data 2 I/O pin	39	47	55	
M_SDAT0_3	MCU HS-SPI0 data 3 I/O pin	42	50	58	
M_SDAT1_0	MCU HS-SPI1 data 0 I/O pin	47	55	63	
M_SDAT1_1	MCU HS-SPI1 data 1 I/O pin	49	57	65	
M_SDAT1_2	MCU HS-SPI1 data 2 I/O pin	48	56	64	
M_SDAT1_3	MCU HS-SPI1 data 3 I/O pin	51	59	67	
M_SSEL0	MCU HS-SPI0 select output pin	41	49	57	
M_SSEL1	MCU HS-SPI1 select output pin	50	58	66	
M_CK	MCU Hyper Bus clock output pin	44	52	60	
M_CS#_1	MCU Hyper Bus select 1 output pin	42	50	58	
M_CS#_2	MCU Hyper Bus select 2 output pin	54	62	70	
M_DQ0	MCU Hyper Bus Data 0 pin	41	49	57	
M_DQ1	MCU Hyper Bus Data 1 pin	40	48	56	
M_DQ2	MCU Hyper Bus Data 2 pin	39	47	55	
M_DQ3	MCU Hyper Bus Data 3 pin	38	46	54	
M_DQ4	MCU Hyper Bus Data 4 pin	48	56	64	
M_DQ5	MCU Hyper Bus Data 5 pin	49	57	65	
M_DQ6	MCU Hyper Bus Data 6 pin	50	58	66	
M_DQ7	MCU Hyper Bus Data 7 pin	51	59	67	
M_RWDS	MCU Hyper Bus RWDS	47	55	63	
COM0	LCDC Segment (Duty) Common Output Pin	15	15	21	
COM1	LCDC Segment (Duty) Common Output Pin	19	26	34	

Port Name	Description	Package Pin Number			Remark
		TEQFP 144	TEQFP 176	TEQFP 208	
COM2	LCDC Segment (Duty) Common Output Pin	20	27	35	
COM3	LCDC Segment (Duty) Common Output Pin	21	28	36	
SEG0	LCDC Segment (Duty) Output Pin	-	154	186	
SEG1	LCDC Segment (Duty) Output Pin	-	155	187	
SEG2	LCDC Segment (Duty) Output Pin	-	156	188	
SEG3	LCDC Segment (Duty) Output Pin	-	157	189	
SEG4	LCDC Segment (Duty) Output Pin	130	158	190	
SEG5	LCDC Segment (Duty) Output Pin	-	162	194	
SEG6	LCDC Segment (Duty) Output Pin	-	163	195	
SEG7	LCDC Segment (Duty) Output Pin	-	164	196	
SEG8	LCDC Segment (Duty) Output Pin	-	165	197	
SEG9	LCDC Segment (Duty) Output Pin	134	166	198	
SEG10	LCDC Segment (Duty) Output Pin	135	167	199	
SEG11	LCDC Segment (Duty) Output Pin	136	168	200	
SEG12	LCDC Segment (Duty) Output Pin	137	169	201	
SEG13	LCDC Segment (Duty) Output Pin	138	170	202	
SEG14	LCDC Segment (Duty) Output Pin	139	171	203	
SEG15	LCDC Segment (Duty) Output Pin	140	172	204	
SEG16	LCDC Segment (Duty) Output Pin	141	173	205	
SEG17	LCDC Segment (Duty) Output Pin	142	174	206	
SEG18	LCDC Segment (Duty) Output Pin	143	175	207	
SEG19	LCDC Segment (Duty) Output Pin	2	2	2	
SEG20	LCDC Segment (Duty) Output Pin	3	3	3	
SEG21	LCDC Segment (Duty) Output Pin	4	4	4	
SEG22	LCDC Segment (Duty) Output Pin	5	5	5	
SEG23	LCDC Segment (Duty/Static) Output Pin	6	6	9	
SEG24	LCDC Segment (Duty/Static) Output Pin	7	7	10	
SEG25	LCDC Segment (Duty/Static) Output Pin	8	8	11	
SEG26	LCDC Segment (Duty/Static) Output Pin	9	9	12	
SEG27	LCDC Segment (Duty/Static) Output Pin	10	10	13	
SEG28	LCDC Segment (Duty/Static) Output Pin	11	11	14	
SEG29	LCDC Segment (Duty/Static) Output Pin	12	12	18	
SEG30	LCDC Segment (Duty/Static) Output Pin	13	13	19	
SEG31	LCDC Segment (Duty/Static) Output Pin	14	14	20	
V0	LCDC Reference Voltage V0 Input Pin	22	30	38	
V1	LCDC Reference Voltage V1 Input Pin	23	31	39	
V2	LCDC Reference Voltage V2 Input Pin	24	32	40	
V3	LCDC Reference Voltage V3 Input Pin	25	33	41	
DSP0_CLK_0	Display 0 Clock output pin	136	168	200	
DSP0_EN_0	Display 0 Data Enable output pin	130	158	190	
DSP0_VSYNC_0	Display 0 Vertical Synchronization output pin	135	167	199	
DSP0_HSYNC_0	Display 0 Horizontal Synchronization output pin	134	166	198	
DSP0_R0_0	Display 0 RGB color output pin (0)	137	169	201	
DSP0_R1_0	Display 0 RGB color output pin (0)	138	170	202	
DSP0_R2_0	Display 0 RGB color output pin (0)	139	171	203	
DSP0_R3_0	Display 0 RGB color output pin (0)	140	172	204	
DSP0_R4_0	Display 0 RGB color output pin (0)	141	173	205	
DSP0_R5_0	Display 0 RGB color output pin (0)	142	174	206	
DSP0_R6_0	Display 0 RGB color output pin (0)	143	175	207	

Port Name	Description	Package Pin Number			Remark
		TEQFP 144	TEQFP 176	TEQFP 208	
DSP0_R7_0	Display 0 RGB color output pin (0)	2	2	2	
DSP0_G0_0	Display 0 RGB color output pin (0)	3	3	3	
DSP0_G1_0	Display 0 RGB color output pin (0)	4	4	4	
DSP0_G2_0	Display 0 RGB color output pin (0)	5	5	5	
DSP0_G3_0	Display 0 RGB color output pin (0)	6	6	9	
DSP0_G4_0	Display 0 RGB color output pin (0)	7	7	10	
DSP0_G5_0	Display 0 RGB color output pin (0)	8	8	11	
DSP0_G6_0	Display 0 RGB color output pin (0)	9	9	12	
DSP0_G7_0	Display 0 RGB color output pin (0)	10	10	13	
DSP0_B0_0	Display 0 RGB color output pin (0)	11	11	14	
DSP0_B1_0	Display 0 RGB color output pin (0)	12	12	18	
DSP0_B2_0	Display 0 RGB color output pin (0)	13	13	19	
DSP0_B3_0	Display 0 RGB color output pin (0)	14	14	20	
DSP0_B4_0	Display 0 RGB color output pin (0)	15	15	21	
DSP0_B5_0	Display 0 RGB color output pin (0)	19	26	34	
DSP0_B6_0	Display 0 RGB color output pin (0)	20	27	35	
DSP0_B7_0	Display 0 RGB color output pin (0)	22	30	38	
DSP0_B7_1	Display 0 RGB color output pin (1)	21	28	36	
LCDD0	LCD Bus IF Data I/O pin	139	171	203	
LCDD1	LCD Bus IF Data I/O pin	140	172	204	
LCDD2	LCD Bus IF Data I/O pin	141	173	205	
LCDD3	LCD Bus IF Data I/O pin	142	174	206	
LCDD4	LCD Bus IF Data I/O pin	143	175	207	
LCDD5	LCD Bus IF Data I/O pin	2	2	2	
LCDD6	LCD Bus IF Data I/O pin	3	3	3	
LCDD7	LCD Bus IF Data I/O pin	4	4	4	
LCDD8	LCD Bus IF Data I/O pin	5	5	5	
LCDD9	LCD Bus IF Data I/O pin	6	6	9	
LCDD10	LCD Bus IF Data I/O pin	7	7	10	
LCDD11	LCD Bus IF Data I/O pin	8	8	11	
LCDD12	LCD Bus IF Data I/O pin	9	9	12	
LCDD13	LCD Bus IF Data I/O pin	10	10	13	
LCDD14	LCD Bus IF Data I/O pin	11	11	14	
LCDD15	LCD Bus IF Data I/O pin	12	12	18	
LCDD16	LCD Bus IF Data I/O pin	13	13	19	
LCDD17	LCD Bus IF Data I/O pin	14	14	20	
CS#	LCD Bus IF Chip Select output pin	15	15	21	
WR#	LCD Bus IF Write enable output pin	19	26	34	
RD#	LCD Bus IF Read enable output pin	20	27	35	
RS	LCD Bus IF Register Select output pin	23	31	39	
TE	LCD Bus IF Tearing Effect input pin	25	33	41	
RES#	LCD Bus IF Reset Control output pin	24	32	40	
ARH0_AIC0_DNCLK	APIX output pin	11	11	14	
ARH0_AIC0_DNDATA0	APIX output pin	21	28	36	
ARH0_AIC0_DNDATA1	APIX output pin	12	12	18	
ARH0_AIC0_RCK	APIX input pin	23	31	39	
ARH0_AIC0_RDA0	APIX input pin	25	33	41	
ARH0_AIC0_RDA1	APIX input pin	24	32	40	
ARH0_AIC0_TCKI	APIX input pin	11	11	14	

Port Name	Description	Package Pin Number			Remark
		TEQFP 144	TEQFP 176	TEQFP 208	
ARH0_AIC0_TDA0	APIX output pin	21	28	36	
ARH0_AIC0_TDA1	APIX output pin	12	12	18	
ARH0_AIC0_UPCLK	APIX input pin	23	31	39	
ARH0_AIC0_UPDATA0	APIX input pin	25	33	41	
ARH0_AIC0_UPDATA1	APIX input pin	24	32	40	
ARH0_AIC0_dbg_out_0	APIX output pin	14	14	20	
ARH0_AIC0_dbg_out_1	APIX output pin	13	13	19	
ARH0_AIC0_dbg_select	APIX input pin	15	15	21	
ARH0_AIC1_DNCLK	APIX output pin	3	3	3	
ARH0_AIC1_DNDATA0	APIX output pin	7	7	10	
ARH0_AIC1_DNDATA1	APIX output pin	4	4	4	
ARH0_AIC1_RCK	APIX input pin	8	8	11	
ARH0_AIC1_RDA0	APIX input pin	10	10	13	
ARH0_AIC1_RDA1	APIX input pin	9	9	12	
ARH0_AIC1_TCKI	APIX input pin	3	3	3	
ARH0_AIC1_TDA0	APIX output pin	7	7	10	
ARH0_AIC1_TDA1	APIX output pin	4	4	4	
ARH0_AIC1_UPCLK	APIX input pin	8	8	11	
ARH0_AIC1_UPDATA0	APIX input pin	10	10	13	
ARH0_AIC1_UPDATA1	APIX input pin	9	9	12	
ARH0_AIC1_dbg_out_0	APIX output pin	6	6	9	
ARH0_AIC1_dbg_out_1	APIX output pin	5	5	5	
ARH0_AIC1_dbg_select	APIX input pin	19	26	34	
INDICATOR0_0	Indicator PWM output pin 0 (It can also obtained from INDICATOR0_1)	70	86	102	
INDICATOR0_1	Indicator PWM output pin 1 (It can also obtained from INDICATOR0_0)	88	112	129	
SYSC0_CLK_0	System clock output pin (0)	93	117	139	
SYSC0_CLK_1	System clock output pin (1)	87	111	128	
MAD0	External Bus pin	143	175	207	
MAD1	External Bus pin	2	2	2	
MAD2	External Bus pin	3	3	3	
MAD3	External Bus pin	4	4	4	
MAD4	External Bus pin	5	5	5	
MAD5	External Bus pin	6	6	9	
MAD6	External Bus pin	7	7	10	
MAD7	External Bus pin	8	8	11	
MAD8	External Bus pin	9	9	12	
MAD9	External Bus pin	10	10	13	
MAD10	External Bus pin	11	11	14	
MAD11	External Bus pin	12	12	18	
MAD12	External Bus pin	13	13	19	
MAD13	External Bus pin	14	14	20	
MAD14	External Bus pin	15	15	21	
MAD15	External Bus pin	-	19	25	
MAD16	External Bus pin	-	20	26	
MAD17	External Bus pin	-	21	27	
MAD18	External Bus pin	-	22	28	
MAD19	External Bus pin	-	23	29	
MAD20	External Bus pin	-	24	32	

Port Name	Description	Package Pin Number			Remark
		TEQFP 144	TEQFP 176	TEQFP 208	
MAD21	External Bus pin	-	25	33	
MDATA0	External Bus pin	135	167	199	
MDATA1	External Bus pin	136	168	200	
MDATA2	External Bus pin	137	169	201	
MDATA3	External Bus pin	138	170	202	
MDATA4	External Bus pin	139	171	203	
MDATA5	External Bus pin	140	172	204	
MDATA6	External Bus pin	141	173	205	
MDATA7	External Bus pin	142	174	206	
MDATA8	External Bus pin	-	154	186	
MDATA9	External Bus pin	-	155	187	
MDATA10	External Bus pin	-	156	188	
MDATA11	External Bus pin	-	157	189	
MDATA12	External Bus pin	-	162	194	
MDATA13	External Bus pin	-	163	195	
MDATA14	External Bus pin	-	164	196	
MDATA15	External Bus pin	-	165	197	
MCLK	External Bus pin	21	28	36	
MOEX	External Bus pin	19	26	34	
MWEX	External Bus pin	20	27	35	
MDQM0	External Bus pin	22	30	38	
MDQM1	External Bus pin	-	29	37	
MCSX0	External Bus pin	130	158	190	
MCSX1	External Bus pin	134	166	198	
MCSX2	External Bus pin	23	31	39	
MCSX3	External Bus pin	24	32	40	
MRDY	External Bus pin	25	33	41	
P0_00	General-Purpose I/O port	2	2	2	
P0_01	General-Purpose I/O port	3	3	3	
P0_02	General-Purpose I/O port	4	4	4	
P0_03	General-Purpose I/O port	5	5	5	
P0_04	General-Purpose I/O port	6	6	9	
P0_05	General-Purpose I/O port	7	7	10	
P0_06	General-Purpose I/O port	8	8	11	
P0_07	General-Purpose I/O port	9	9	12	
P0_08	General-Purpose I/O port	10	10	13	
P0_09	General-Purpose I/O port	11	11	14	
P0_10	General-Purpose I/O port	12	12	18	
P0_11	General-Purpose I/O port	13	13	19	
P0_12	General-Purpose I/O port	14	14	20	
P0_13	General-Purpose I/O port	15	15	21	
P0_14	General-Purpose I/O port	19	26	34	
P0_15	General-Purpose I/O port	20	27	35	
P0_16	General-Purpose I/O port	21	28	36	
P0_17	General-Purpose I/O port	22	30	38	
P0_18	General-Purpose I/O port	23	31	39	
P0_19	General-Purpose I/O port	24	32	40	
P0_20	General-Purpose input port	25	33	41	
P0_21	General-Purpose I/O port	38	46	54	

Port Name	Description	Package Pin Number			Remark
		TEQFP 144	TEQFP 176	TEQFP 208	
P0_22	General-Purpose I/O port	39	47	55	
P0_23	General-Purpose I/O port	40	48	56	
P0_24	General-Purpose I/O port	41	49	57	
P0_25	General-Purpose I/O port	42	50	58	
P0_26	General-Purpose I/O port	44	52	60	
P0_27	General-Purpose I/O port	47	55	63	
P0_28	General-Purpose I/O port	48	56	64	
P0_29	General-Purpose I/O port	49	57	65	
P0_30	General-Purpose I/O port	50	58	66	
P0_31	General-Purpose I/O port	51	59	67	
P1_00	General-Purpose I/O port	54	62	70	
P1_01	General-Purpose I/O port	55	63	71	
P1_02	General-Purpose I/O port	56	64	72	
P1_03	General-Purpose I/O port	61	73	85	
P1_04	General-Purpose I/O port	62	74	86	
P1_05	General-Purpose I/O port	63	77	89	
P1_06	General-Purpose I/O port	64	78	90	
P1_07	General-Purpose I/O port	65	81	93	
P1_08	General-Purpose I/O port	66	82	94	
P1_09	General-Purpose I/O port	67	83	95	
P1_10	General-Purpose I/O port	68	84	98	
P1_11	General-Purpose I/O port	70	86	102	
P1_12	General-Purpose I/O port	71	87	103	
P1_13	General-Purpose I/O port	81	97	113	
P1_14	General-Purpose I/O port	87	111	128	
P1_15	General-Purpose I/O port	88	112	129	
P1_16	General-Purpose I/O port	93	117	139	
P1_17	General-Purpose I/O port	100	124	148	
P1_18	General-Purpose I/O port	101	125	149	
P1_19	General-Purpose I/O port	102	126	150	
P1_20	General-Purpose I/O port	103	127	151	
P1_21	General-Purpose I/O port	104	128	152	
P1_22	General-Purpose I/O port	105	129	153	
P1_23	General-Purpose I/O port	106	130	154	
P1_24	General-Purpose I/O port	107	131	155	
P1_25	General-Purpose I/O port	110	134	158	
P1_26	General-Purpose I/O port	111	135	160	
P1_27	General-Purpose I/O port	112	136	161	
P1_28	General-Purpose I/O port	113	137	162	
P1_29	General-Purpose I/O port	114	138	164	
P1_30	General-Purpose I/O port	115	139	165	
P1_31	General-Purpose I/O port	116	140	166	
P2_00	General-Purpose I/O port	117	141	168	
P2_01	General-Purpose I/O port	120	144	171	
P2_02	General-Purpose I/O port	121	145	173	
P2_03	General-Purpose I/O port	122	146	174	
P2_04	General-Purpose I/O port	123	147	175	
P2_05	General-Purpose I/O port	124	148	177	
P2_06	General-Purpose I/O port	125	149	178	



Port Name	Description	Package Pin Number			Remark
		TEQFP 144	TEQFP 176	TEQFP 208	
P2_07	General-Purpose I/O port	126	150	179	
P2_08	General-Purpose I/O port	127	151	181	
P2_09	General-Purpose I/O port	130	158	190	
P2_10	General-Purpose I/O port	134	166	198	
P2_11	General-Purpose I/O port	135	167	199	
P2_12	General-Purpose I/O port	136	168	200	
P2_13	General-Purpose I/O port	137	169	201	
P2_14	General-Purpose I/O port	138	170	202	
P2_15	General-Purpose I/O port	139	171	203	
P2_16	General-Purpose I/O port	140	172	204	
P2_17	General-Purpose I/O port	141	173	205	
P2_18	General-Purpose I/O port	142	174	206	
P2_19	General-Purpose I/O port	143	175	207	
P3_00	General-Purpose I/O port	-	19	25	
P3_01	General-Purpose I/O port	-	20	26	
P3_02	General-Purpose I/O port	-	21	27	
P3_03	General-Purpose I/O port	-	22	28	
P3_04	General-Purpose I/O port	-	23	29	
P3_05	General-Purpose I/O port	-	24	32	
P3_06	General-Purpose I/O port	-	25	33	
P3_07	General-Purpose I/O port	-	29	37	
P3_08	General-Purpose I/O port	-	69	81	
P3_09	General-Purpose I/O port	-	70	82	
P3_10	General-Purpose I/O port	-	71	83	
P3_11	General-Purpose I/O port	-	72	84	
P3_12	General-Purpose I/O port	-	75	87	
P3_13	General-Purpose I/O port	-	76	88	
P3_14	General-Purpose I/O port	-	79	91	
P3_15	General-Purpose I/O port	-	80	92	
P3_16	General-Purpose I/O port	-	98	114	
P3_17	General-Purpose I/O port	-	99	115	
P3_18	General-Purpose I/O port	-	105	122	
P3_19	General-Purpose I/O port	-	106	123	
P3_20	General-Purpose I/O port	-	107	124	
P3_21	General-Purpose I/O port	-	108	125	
P3_22	General-Purpose I/O port	-	109	126	
P3_23	General-Purpose I/O port	-	110	127	
P3_24	General-Purpose I/O port	-	154	186	
P3_25	General-Purpose I/O port	-	155	187	
P3_26	General-Purpose I/O port	-	156	188	
P3_27	General-Purpose I/O port	-	157	189	
P3_28	General-Purpose I/O port	-	162	194	
P3_29	General-Purpose I/O port	-	163	195	
P3_30	General-Purpose I/O port	-	164	196	
P3_31	General-Purpose I/O port	-	165	197	
P4_00	General-Purpose I/O port	-	-	6	
P4_01	General-Purpose I/O port	-	-	7	
P4_02	General-Purpose I/O port	-	-	8	
P4_03	General-Purpose I/O port	-	-	15	

Port Name	Description	Package Pin Number			Remark
		TEQFP 144	TEQFP 176	TEQFP 208	
P4_04	General-Purpose I/O port	-	-	16	
P4_05	General-Purpose I/O port	-	-	17	
P4_06	General-Purpose I/O port	-	-	30	
P4_07	General-Purpose I/O port	-	-	31	
P4_08	General-Purpose I/O port	-	-	77	
P4_09	General-Purpose I/O port	-	-	78	
P4_10	General-Purpose I/O port	-	-	79	
P4_11	General-Purpose I/O port	-	-	80	
P4_12	General-Purpose I/O port	-	-	96	
P4_13	General-Purpose I/O port	-	-	97	
P4_14	General-Purpose I/O port	-	-	99	
P4_15	General-Purpose I/O port	-	-	100	
P4_16	General-Purpose I/O port	-	-	116	
P4_17	General-Purpose I/O port	-	-	130	
P4_18	General-Purpose I/O port	-	-	131	
P4_19	General-Purpose I/O port	-	-	136	
P4_20	General-Purpose I/O port	-	-	137	
P4_21	General-Purpose I/O port	-	-	138	
P4_22	General-Purpose I/O port	-	-	140	
P4_23	General-Purpose I/O port	-	-	141	
P4_24	General-Purpose I/O port	-	-	159	
P4_25	General-Purpose I/O port	-	-	163	
P4_26	General-Purpose I/O port	-	-	167	
P4_27	General-Purpose I/O port	-	-	172	
P4_28	General-Purpose I/O port	-	-	176	
P4_29	General-Purpose I/O port	-	-	180	
P4_30	General-Purpose I/O port	-	-	184	
P4_31	General-Purpose I/O port	-	-	185	

## 6.2 Remark

### Notes:

- The port description list shows the port function of description which is mounted and supported on the product. The function which is not described in this table is not supported and assured.
- See the function list of the product as well.

## 7. Port Configuration

### 7.1 Resource Input Configuration Module

The resource input configuration module (RIC) is a function to select input from an external or output from another internal resource as resource input. A resource which supports either a port input relocation or a resource inputs from the other resource has its RIC\_RESIN register to configure resource input configuration. The Resource which are available through only one port does not have the multiplexer implemented i.e. No RIC\_RESIN register.

#### 7.1.1 RIC (S6J3310)

Register (Offset)	Resource	RESSEL [3:0] /PORT SEL[3:0]	Source for Resource Input												
			0	1	2	3	4	5	6	7					
			8	9	10	11	12	13	14	15					
RIC_RE SIN000 (0x0000)	SIN16	RESSEL (0-7)	-	-	-	-	-	-	-	-	-	-	-	-	-
		RESSEL (8-15)	-	-	-	-	-	-	-	-	-	-	-	-	-
		PORTSE L (0-7)	P1_08	P4_19	-	-	-	-	-	-	-	-	-	-	-
		PORTSE L (8-15)	-	-	-	-	-	-	-	-	-	-	-	-	-
RIC_RE SIN001 (0x0002)	SCK16	RESSEL (0-7)	-	-	-	-	-	-	-	-	-	-	-	-	
		RESSEL (8-15)	-	-	-	-	-	-	-	-	-	-	-	-	
		PORTSE L (0-7)	P1_09	P4_21	-	-	-	-	-	-	-	-	-	-	
		PORTSE L (8-15)	-	-	-	-	-	-	-	-	-	-	-	-	
RIC_RE SIN002 (0x0004)	SCL16	RESSEL (0-7)	80 ns noise filter disable	80 ns noise filter enable	-	-	-	-	-	-	-	-	-	-	
		RESSEL (8-15)	-	-	-	-	-	-	-	-	-	-	-	-	
		PORTSE L (0-7)	-	-	-	-	-	-	-	-	-	-	-	-	
		PORTSE L (8-15)	-	-	-	-	-	-	-	-	-	-	-	-	
RIC_RE SIN003 (0x0006)	SDA16	RESSEL (0-7)	80 ns noise filter disable	80 ns noise filter enable	-	-	-	-	-	-	-	-	-	-	
		RESSEL (8-15)	-	-	-	-	-	-	-	-	-	-	-	-	
		PORTSE L (0-7)	-	-	-	-	-	-	-	-	-	-	-	-	
		PORTSE L (8-15)	-	-	-	-	-	-	-	-	-	-	-	-	

Register (Offset)	Resource	RESSEL [3:0] /PORT SEL[3:0]	Source for Resource Input							
			0	1	2	3	4	5	6	7
			8	9	10	11	12	13	14	15
RIC_RE SIN004 (0x0008)	MFS16_T RIGGER	RESSEL (0-7)	TOT48	TOT49	-	-	-	-	-	-
		RESSEL (8-15)	-	-	-	-	-	-	-	-
		PORTSE L (0-7)	-	-	-	-	-	-	-	-
		PORTSE L (8-15)	-	-	-	-	-	-	-	-
RIC_RE SIN005 (0x000A)	SCS16	RESSEL (0-7)	-	-	-	-	-	-	-	-
		RESSEL (8-15)	-	-	-	-	-	-	-	-
		PORTSE L (0-7)	P1_11	P4_23	-	-	-	-	-	-
		PORTSE L (8-15)	-	-	-	-	-	-	-	-
RIC_RE SIN007 (0x000E)	SIN17	RESSEL (0-7)	-	-	-	-	-	-	-	-
		RESSEL (8-15)	-	-	-	-	-	-	-	-
		PORTSE L (0-7)	P1_14	P0_09	-	-	-	-	-	-
		PORTSE L (8-15)	-	-	-	-	-	-	-	-
RIC_RE SIN008 (0x0010)	SCK17	RESSEL (0-7)	-	-	-	-	-	-	-	-
		RESSEL (8-15)	-	-	-	-	-	-	-	-
		PORTSE L (0-7)	P1_15	P4_04	-	-	-	-	-	-
		PORTSE L (8-15)	-	-	-	-	-	-	-	-
RIC_RE SIN009 (0x0012)	SCL17	RESSEL (0-7)	80 ns noise filter disable	80 ns noise filter enable	-	-	-	-	-	-
		RESSEL (8-15)	-	-	-	-	-	-	-	-
		PORTSE L (0-7)	-	-	-	-	-	-	-	-
		PORTSE L (8-15)	-	-	-	-	-	-	-	-

Register (Offset)	Resource	RESSEL [3:0] /PORT SEL[3:0]	Source for Resource Input										
			0	1	2	3	4	5	6	7			
			8	9	10	11	12	13	14	15			
RIC_RE SIN010 (0x0014)	SDA17	RESSEL (0-7)	80 ns noise filter disable	80 ns noise filter enable	-	-	-	-	-	-	-	-	-
		RESSEL (8-15)	-	-	-	-	-	-	-	-	-	-	-
		PORTSEL (0-7)	-	-	-	-	-	-	-	-	-	-	-
		PORTSEL (8-15)	-	-	-	-	-	-	-	-	-	-	-
RIC_RE SIN011 (0x0016)	MFS17_T RIGGER	RESSEL (0-7)	TOT48	TOT49	-	-	-	-	-	-	-	-	-
		RESSEL (8-15)	-	-	-	-	-	-	-	-	-	-	-
		PORTSEL (0-7)	-	-	-	-	-	-	-	-	-	-	-
		PORTSEL (8-15)	-	-	-	-	-	-	-	-	-	-	-
RIC_RE SIN012 (0x0018)	SCS17	RESSEL (0-7)	-	-	-	-	-	-	-	-	-	-	-
		RESSEL (8-15)	-	-	-	-	-	-	-	-	-	-	-
		PORTSEL (0-7)	P1_17	P4_03	-	-	-	-	-	-	-	-	-
		PORTSEL (8-15)	-	-	-	-	-	-	-	-	-	-	-
RIC_RE SIN021 (0x002A)	SIN0	RESSEL (0-7)	-	-	-	-	-	-	-	-	-	-	-
		RESSEL (8-15)	-	-	-	-	-	-	-	-	-	-	-
		PORTSEL (0-7)	P1_03	P0_04	-	-	-	-	-	-	-	-	-
		PORTSEL (8-15)	-	-	-	-	-	-	-	-	-	-	-
RIC_RE SIN022 (0x002C)	SCK0	RESSEL (0-7)	-	-	-	-	-	-	-	-	-	-	-
		RESSEL (8-15)	-	-	-	-	-	-	-	-	-	-	-
		PORTSEL (0-7)	P1_04	P0_06	-	-	-	-	-	-	-	-	-
		PORTSEL (8-15)	-	-	-	-	-	-	-	-	-	-	-

Register (Offset)	Resource	RESSEL [3:0] /PORT SEL[3:0]	Source for Resource Input							
			0	1	2	3	4	5	6	7
			8	9	10	11	12	13	14	15
RIC_RE SIN023 (0x002E)	SCL0	RESSEL (0-7)	80 ns noise filter disable	80 ns noise filter enable	-	-	-	-	-	-
		RESSEL (8-15)	-	-	-	-	-	-	-	-
		PORTSEL (0-7)	-	-	-	-	-	-	-	-
		PORTSEL (8-15)	-	-	-	-	-	-	-	-
RIC_RE SIN024 (0x0030)	SDA0	RESSEL (0-7)	80 ns noise filter disable	80 ns noise filter enable	-	-	-	-	-	-
		RESSEL (8-15)	-	-	-	-	-	-	-	-
		PORTSEL (0-7)	-	-	-	-	-	-	-	-
		PORTSEL (8-15)	-	-	-	-	-	-	-	-
RIC_RE SIN025 (0x0032)	MFS0_TRIGGER	RESSEL (0-7)	TOT0	TOT1	-	-	-	-	-	-
		RESSEL (8-15)	-	-	-	-	-	-	-	-
		PORTSEL (0-7)	-	-	-	-	-	-	-	-
		PORTSEL (8-15)	-	-	-	-	-	-	-	-
RIC_RE SIN026 (0x0034)	SCS0	RESSEL (0-7)	-	-	-	-	-	-	-	-
		RESSEL (8-15)	-	-	-	-	-	-	-	-
		PORTSEL (0-7)	P1_06	P0_07	-	-	-	-	-	-
		PORTSEL (8-15)	-	-	-	-	-	-	-	-
RIC_RE SIN028 (0x0038)	SIN1	RESSEL (0-7)	-	-	-	-	-	-	-	-
		RESSEL (8-15)	-	-	-	-	-	-	-	-
		PORTSEL (0-7)	P0_01	P3_00	-	-	-	-	-	-
		PORTSEL (8-15)	-	-	-	-	-	-	-	-

Register (Offset)	Resource	RESSEL [3:0] /PORT SEL[3:0]	Source for Resource Input							
			0	1	2	3	4	5	6	7
			8	9	10	11	12	13	14	15
RIC_RE SIN029 (0x003A)	SCK1	RESSEL (0-7)	-	-	-	-	-	-	-	-
		RESSEL (8-15)	-	-	-	-	-	-	-	-
		PORTSE L (0-7)	P0_02	P3_01	-	-	-	-	-	-
		PORTSE L (8-15)	-	-	-	-	-	-	-	-
RIC_RE SIN030 (0x003C)	SCL1	RESSEL (0-7)	80 ns noise filter disable	80 ns noise filter enable	-	-	-	-	-	-
		RESSEL (8-15)	-	-	-	-	-	-	-	-
		PORTSE L (0-7)	-	-	-	-	-	-	-	-
		PORTSE L (8-15)	-	-	-	-	-	-	-	-
RIC_RE SIN031 (0x003E)	SDA1	RESSEL (0-7)	80 ns noise filter disable	80 ns noise filter enable	-	-	-	-	-	-
		RESSEL (8-15)	-	-	-	-	-	-	-	-
		PORTSE L (0-7)	-	-	-	-	-	-	-	-
		PORTSE L (8-15)	-	-	-	-	-	-	-	-
RIC_RE SIN032 (0x0040)	MFS1_TR IGGER	RESSEL (0-7)	TOT0	TOT1	-	-	-	-	-	-
		RESSEL (8-15)	-	-	-	-	-	-	-	-
		PORTSE L (0-7)	-	-	-	-	-	-	-	-
		PORTSE L (8-15)	-	-	-	-	-	-	-	-
RIC_RE SIN033 (0x0042)	SCS1	RESSEL (0-7)	-	-	-	-	-	-	-	-
		RESSEL (8-15)	-	-	-	-	-	-	-	-
		PORTSE L (0-7)	P0_04	P3_03	-	-	-	-	-	-
		PORTSE L (8-15)	-	-	-	-	-	-	-	-

Register (Offset)	Resource	RESSEL [3:0] /PORT SEL[3:0]	Source for Resource Input							
			0	1	2	3	4	5	6	7
			8	9	10	11	12	13	14	15
RIC_RE SIN035 (0x0046)	SIN2	RESSEL (0-7)	-	-	-	-	-	-	-	-
		RESSEL (8-15)	-	-	-	-	-	-	-	-
		PORTSE L (0-7)	P0_21	P4_30	-	-	-	-	-	-
		PORTSE L (8-15)	-	-	-	-	-	-	-	-
RIC_RE SIN036 (0x0048)	SCK2	RESSEL (0-7)	-	-	-	-	-	-	-	-
		RESSEL (8-15)	-	-	-	-	-	-	-	-
		PORTSE L (0-7)	P0_22	P4_31	-	-	-	-	-	-
		PORTSE L (8-15)	-	-	-	-	-	-	-	-
RIC_RE SIN039 (0x004E)	MFS2_TR IGGER	RESSEL (0-7)	TOT0	TOT1	-	-	-	-	-	-
		RESSEL (8-15)	-	-	-	-	-	-	-	-
		PORTSE L (0-7)	-	-	-	-	-	-	-	-
		PORTSE L (8-15)	-	-	-	-	-	-	-	-
RIC_RE SIN040 (0x0050)	SCS2	RESSEL (0-7)	-	-	-	-	-	-	-	-
		RESSEL (8-15)	-	-	-	-	-	-	-	-
		PORTSE L (0-7)	P0_24	P3_25	-	-	-	-	-	-
		PORTSE L (8-15)	-	-	-	-	-	-	-	-



Register (Offset)	Resource	RESSEL [3:0] /PORT SEL[3:0]	Source for Resource Input							
			0	1	2	3	4	5	6	7
			8	9	10	11	12	13	14	15
RIC_RE SIN042 (0x0054)	SIN3	RESSEL (0-7)	-	-	-	-	-	-	-	-
		RESSEL (8-15)	-	-	-	-	-	-	-	-
		PORTSE L (0-7)	P0_28	P3_28	-	-	-	-	-	-
		PORTSE L (8-15)	-	-	-	-	-	-	-	-
RIC_RE SIN043 (0x0056)	SCK3	RESSEL (0-7)	-	-	-	-	-	-	-	-
		RESSEL (8-15)	-	-	-	-	-	-	-	-
		PORTSE L (0-7)	P0_29	P3_29	-	-	-	-	-	-
		PORTSE L (8-15)	-	-	-	-	-	-	-	-
RIC_RE SIN046 (0x005C)	MFS3_TR IGGER	RESSEL (0-7)	TOT0	TOT1	-	-	-	-	-	-
		RESSEL (8-15)	-	-	-	-	-	-	-	-
		PORTSE L (0-7)	-	-	-	-	-	-	-	-
		PORTSE L (8-15)	-	-	-	-	-	-	-	-
RIC_RE SIN047 (0x005E)	SCS3	RESSEL (0-7)	-	-	-	-	-	-	-	-
		RESSEL (8-15)	-	-	-	-	-	-	-	-
		PORTSE L (0-7)	P0_31	P3_31	-	-	-	-	-	-
		PORTSE L (8-15)	-	-	-	-	-	-	-	-
RIC_RE SIN049 (0x0062)	SIN4	RESSEL (0-7)	-	-	-	-	-	-	-	-
		RESSEL (8-15)	-	-	-	-	-	-	-	-
		PORTSE L (0-7)	P2_13	P3_05	-	-	-	-	-	-
		PORTSE L (8-15)	-	-	-	-	-	-	-	-

Register (Offset)	Resource	RESSEL [3:0] /PORT SEL[3:0]	Source for Resource Input							
			0	1	2	3	4	5	6	7
			8	9	10	11	12	13	14	15
RIC_RE SIN050 (0x0064)	SCK4	RESSEL (0-7)	-	-	-	-	-	-	-	-
		RESSEL (8-15)	-	-	-	-	-	-	-	-
		PORTSE L (0-7)	P2_14	P0_14	-	-	-	-	-	-
		PORTSE L (8-15)	-	-	-	-	-	-	-	-
RIC_RE SIN051 (0x0066)	SCL4	RESSEL (0-7)	80 ns noise filter disable	80 ns noise filter enable	-	-	-	-	-	
		RESSEL (8-15)	-	-	-	-	-	-	-	
		PORTSE L (0-7)	-	-	-	-	-	-	-	
		PORTSE L (8-15)	-	-	-	-	-	-	-	
RIC_RE SIN052 (0x0068)	SDA4	RESSEL (0-7)	80 ns noise filter disable	80 ns noise filter enable	-	-	-	-	-	
		RESSEL (8-15)	-	-	-	-	-	-	-	
		PORTSE L (0-7)	-	-	-	-	-	-	-	
		PORTSE L (8-15)	-	-	-	-	-	-	-	
RIC_RE SIN053 (0x006A)	MFS4_TR IGGER	RESSEL (0-7)	TOT0	TOT1	-	-	-	-	-	
		RESSEL (8-15)	-	-	-	-	-	-	-	
		PORTSE L (0-7)	-	-	-	-	-	-	-	
		PORTSE L (8-15)	-	-	-	-	-	-	-	
RIC_RE SIN054 (0x006C)	SCS4	RESSEL (0-7)	-	-	-	-	-	-	-	
		RESSEL (8-15)	-	-	-	-	-	-	-	
		PORTSE L (0-7)	P2_16	P0_15	-	-	-	-	-	
		PORTSE L (8-15)	-	-	-	-	-	-	-	

Register (Offset)	Resource	RESSEL [3:0] /PORT SEL[3:0]	Source for Resource Input							
			0	1	2	3	4	5	6	7
			8	9	10	11	12	13	14	15
RIC_RE SIN077 (0x009A)	SIN8	RESSEL (0-7)	-	-	-	-	-	-	-	-
		RESSEL (8-15)	-	-	-	-	-	-	-	-
		PORTSE L (0-7)	P1_19	P3_08	P0_27	-	-	-	-	-
		PORTSE L (8-15)	-	-	-	-	-	-	-	-
RIC_RE SIN078 (0x009C)	SCK8	RESSEL (0-7)	-	-	-	-	-	-	-	-
		RESSEL (8-15)	-	-	-	-	-	-	-	-
		PORTSE L (0-7)	P1_20	P3_09	P0_28	-	-	-	-	-
		PORTSE L (8-15)	-	-	-	-	-	-	-	-
RIC_RE SIN079 (0x009E)	SCL8	RESSEL (0-7)	80 ns noise filter disable	80 ns noise filter enable	-	-	-	-	-	-
		RESSEL (8-15)	-	-	-	-	-	-	-	-
		PORTSE L (0-7)	-	-	-	-	-	-	-	-
		PORTSE L (8-15)	-	-	-	-	-	-	-	-
RIC_RE SIN080 (0x00A0)	SDA8	RESSEL (0-7)	80 ns noise filter disable	80 ns noise filter enable	-	-	-	-	-	-
		RESSEL (8-15)	-	-	-	-	-	-	-	-
		PORTSE L (0-7)	-	-	-	-	-	-	-	-
		PORTSE L (8-15)	-	-	-	-	-	-	-	-
RIC_RE SIN081 (0x00A2)	MFS8_TR IGGER	RESSEL (0-7)	TOT16	TOT17	-	-	-	-	-	-
		RESSEL (8-15)	-	-	-	-	-	-	-	-
		PORTSE L (0-7)	-	-	-	-	-	-	-	-
		PORTSE L (8-15)	-	-	-	-	-	-	-	-

Register (Offset)	Resource	RESSEL [3:0] /PORT SEL[3:0]	Source for Resource Input									
			0	1	2	3	4	5	6	7		
			8	9	10	11	12	13	14	15		
RIC_RE SIN082 (0x00A4)	SCS8	RESSEL (0-7)	-	-	-	-	-	-	-	-	-	
		RESSEL (8-15)	-	-	-	-	-	-	-	-	-	
		PORTSE L (0-7)	P1_22	P3_11	P0_30	-	-	-	-	-	-	
		PORTSE L (8-15)	-	-	-	-	-	-	-	-	-	
RIC_RE SIN084 (0x00A8)	SIN9	RESSEL (0-7)	-	-	-	-	-	-	-	-	-	
		RESSEL (8-15)	-	-	-	-	-	-	-	-	-	
		PORTSE L (0-7)	P1_23	P3_18	P0_21	-	-	-	-	-	-	
		PORTSE L (8-15)	-	-	-	-	-	-	-	-	-	
RIC_RE SIN085 (0x00AA)	SCK9	RESSEL (0-7)	-	-	-	-	-	-	-	-	-	
		RESSEL (8-15)	-	-	-	-	-	-	-	-	-	
		PORTSE L (0-7)	P1_24	P3_19	P0_23	-	-	-	-	-	-	
		PORTSE L (8-15)	-	-	-	-	-	-	-	-	-	
RIC_RE SIN086 (0x00AC)	SCL9	RESSEL (0-7)	80 ns noise filter disable	80 ns noise filter enable	-	-	-	-	-	-	-	
		RESSEL (8-15)	-	-	-	-	-	-	-	-	-	
		PORTSE L (0-7)	-	-	-	-	-	-	-	-	-	
		PORTSE L (8-15)	-	-	-	-	-	-	-	-	-	
RIC_RE SIN087 (0x00AE)	SDA9	RESSEL (0-7)	80 ns noise filter disable	80 ns noise filter enable	-	-	-	-	-	-	-	
		RESSEL (8-15)	-	-	-	-	-	-	-	-	-	
		PORTSE L (0-7)	-	-	-	-	-	-	-	-	-	
		PORTSE L (8-15)	-	-	-	-	-	-	-	-	-	

Register (Offset)	Resource	RESSEL [3:0] /PORT SEL[3:0]	Source for Resource Input							
			0	1	2	3	4	5	6	7
			8	9	10	11	12	13	14	15
RIC_RE SIN088 (0x00B0)	MFS9_TRIGGER	RESSEL (0-7)	TOT16	TOT17	-	-	-	-	-	-
		RESSEL (8-15)	-	-	-	-	-	-	-	-
		PORTSEL (0-7)	-	-	-	-	-	-	-	-
		PORTSEL (8-15)	-	-	-	-	-	-	-	-
RIC_RE SIN089 (0x00B2)	SCS9	RESSEL (0-7)	-	-	-	-	-	-	-	-
		RESSEL (8-15)	-	-	-	-	-	-	-	-
		PORTSEL (0-7)	P1_26	P3_21	P0_24	-	-	-	-	-
		PORTSEL (8-15)	-	-	-	-	-	-	-	-
RIC_RE SIN091 (0x00B6)	SIN10	RESSEL (0-7)	-	-	-	-	-	-	-	-
		RESSEL (8-15)	-	-	-	-	-	-	-	-
		PORTSEL (0-7)	P1_28	P3_12	-	-	-	-	-	-
		PORTSEL (8-15)	-	-	-	-	-	-	-	-
RIC_RE SIN092 (0x00B8)	SCK10	RESSEL (0-7)	-	-	-	-	-	-	-	-
		RESSEL (8-15)	-	-	-	-	-	-	-	-
		PORTSEL (0-7)	P1_29	P3_13	-	-	-	-	-	-
		PORTSEL (8-15)	-	-	-	-	-	-	-	-
RIC_RE SIN093 (0x00BA)	SCL10	RESSEL (0-7)	80 ns noise filter disable	80 ns noise filter enable	-	-	-	-	-	-
		RESSEL (8-15)	-	-	-	-	-	-	-	-
		PORTSEL (0-7)	-	-	-	-	-	-	-	-
		PORTSEL (8-15)	-	-	-	-	-	-	-	-

Register (Offset)	Resource	RESSEL [3:0] /PORT SEL[3:0]	Source for Resource Input										
			0	1	2	3	4	5	6	7			
			8	9	10	11	12	13	14	15			
RIC_RE SIN094 (0x00BC)	SDA10	RESSEL (0-7)	80 ns noise filter disable	80 ns noise filter enable	-	-	-	-	-	-	-	-	-
		RESSEL (8-15)	-	-	-	-	-	-	-	-	-	-	-
		PORTSE L (0-7)	-	-	-	-	-	-	-	-	-	-	-
		PORTSE L (8-15)	-	-	-	-	-	-	-	-	-	-	-
RIC_RE SIN095 (0x00BE)	MFS10_T RIGGER	RESSEL (0-7)	TOT16	TOT17	-	-	-	-	-	-	-	-	-
		RESSEL (8-15)	-	-	-	-	-	-	-	-	-	-	-
		PORTSE L (0-7)	-	-	-	-	-	-	-	-	-	-	-
		PORTSE L (8-15)	-	-	-	-	-	-	-	-	-	-	-
RIC_RE SIN096 (0x00C0)	SCS10	RESSEL (0-7)	-	-	-	-	-	-	-	-	-	-	-
		RESSEL (8-15)	-	-	-	-	-	-	-	-	-	-	-
		PORTSE L (0-7)	P1_31	P3_15	-	-	-	-	-	-	-	-	-
		PORTSE L (8-15)	-	-	-	-	-	-	-	-	-	-	-
RIC_RE SIN100 (0x00C8)	SCL11	RESSEL (0-7)	80 ns noise filter disable	80 ns noise filter enable	-	-	-	-	-	-	-	-	-
		RESSEL (8-15)	-	-	-	-	-	-	-	-	-	-	-
		PORTSE L (0-7)	-	-	-	-	-	-	-	-	-	-	-
		PORTSE L (8-15)	-	-	-	-	-	-	-	-	-	-	-

Register (Offset)	Resource	RESSEL [3:0] /PORT SEL[3:0]	Source for Resource Input										
			0	1	2	3	4	5	6	7			
			8	9	10	11	12	13	14	15			
RIC_RE SIN101 (0x00CA)	SDA11	RESSEL (0-7)	80 ns noise filter disable	80 ns noise filter enable	-	-	-	-	-	-	-	-	-
		RESSEL (8-15)	-	-	-	-	-	-	-	-	-	-	-
		PORTSEL (0-7)	-	-	-	-	-	-	-	-	-	-	-
		PORTSEL (8-15)	-	-	-	-	-	-	-	-	-	-	-
RIC_RE SIN102 (0x00CC)	MFS11_T RIGGER	RESSEL (0-7)	TOT16	TOT17	-	-	-	-	-	-	-	-	-
		RESSEL (8-15)	-	-	-	-	-	-	-	-	-	-	-
		PORTSEL (0-7)	-	-	-	-	-	-	-	-	-	-	-
		PORTSEL (8-15)	-	-	-	-	-	-	-	-	-	-	-
RIC_RE SIN105 (0x00D2)	SIN12	RESSEL (0-7)	-	-	-	-	-	-	-	-	-	-	-
		RESSEL (8-15)	-	-	-	-	-	-	-	-	-	-	-
		PORTSEL (0-7)	P2_05	P4_18	-	-	-	-	-	-	-	-	-
		PORTSEL (8-15)	-	-	-	-	-	-	-	-	-	-	-
RIC_RE SIN106 (0x00D4)	SCK12	RESSEL (0-7)	-	-	-	-	-	-	-	-	-	-	-
		RESSEL (8-15)	-	-	-	-	-	-	-	-	-	-	-
		PORTSEL (0-7)	P2_06	P1_15	-	-	-	-	-	-	-	-	-
		PORTSEL (8-15)	-	-	-	-	-	-	-	-	-	-	-
RIC_RE SIN107 (0x00D6)	SCL12	RESSEL (0-7)	80 ns noise filter disable	80 ns noise filter enable	-	-	-	-	-	-	-	-	-
		RESSEL (8-15)	-	-	-	-	-	-	-	-	-	-	-
		PORTSEL (0-7)	-	-	-	-	-	-	-	-	-	-	-
		PORTSEL (8-15)	-	-	-	-	-	-	-	-	-	-	-

Register (Offset)	Resource	RESSEL [3:0] /PORT SEL[3:0]	Source for Resource Input										
			0	1	2	3	4	5	6	7			
			8	9	10	11	12	13	14	15			
RIC_RE SIN108 (0x00D8)	SDA12	RESSEL (0-7)	80 ns noise filter disable	80 ns noise filter enable	-	-	-	-	-	-	-	-	-
		RESSEL (8-15)	-	-	-	-	-	-	-	-	-	-	-
		PORTSEL (0-7)	-	-	-	-	-	-	-	-	-	-	-
		PORTSEL (8-15)	-	-	-	-	-	-	-	-	-	-	-
RIC_RE SIN109 (0x00DA)	MFS12_T RIGGER	RESSEL (0-7)	TOT16	TOT17	-	-	-	-	-	-	-	-	-
		RESSEL (8-15)	-	-	-	-	-	-	-	-	-	-	-
		PORTSEL (0-7)	-	-	-	-	-	-	-	-	-	-	-
		PORTSEL (8-15)	-	-	-	-	-	-	-	-	-	-	-
RIC_RE SIN110 (0x00DC)	SCS12	RESSEL (0-7)	-	-	-	-	-	-	-	-	-	-	-
		RESSEL (8-15)	-	-	-	-	-	-	-	-	-	-	-
		PORTSEL (0-7)	P2_08	P3_23	-	-	-	-	-	-	-	-	-
		PORTSEL (8-15)	-	-	-	-	-	-	-	-	-	-	-
RIC_RE SIN133 (0x010A)	RX5	RESSEL (0-7)	PORT_PIN	MCAN5_PIN_A_ND_TX	-	-	-	-	-	-	-	-	-
		RESSEL (8-15)	-	-	-	-	-	-	-	-	-	-	-
		PORTSEL (0-7)	P1_17	P3_19	-	-	-	-	-	-	-	-	-
		PORTSEL (8-15)	-	-	-	-	-	-	-	-	-	-	-
RIC_RE SIN134 (0x010C)	RX6	RESSEL (0-7)	PORT_PIN	MCAN6_PIN_A_ND_TX	-	-	-	-	-	-	-	-	-
		RESSEL (8-15)	-	-	-	-	-	-	-	-	-	-	-
		PORTSEL (0-7)	P1_21	P3_22	-	-	-	-	-	-	-	-	-
		PORTSEL (8-15)	-	-	-	-	-	-	-	-	-	-	-



Register (Offset)	Resource	RESSEL [3:0] /PORT SEL[3:0]	Source for Resource Input										
			0	1	2	3	4	5	6	7			
			8	9	10	11	12	13	14	15			
RIC_RE SIN136 (0x0110)	RX0	RESSEL (0-7)	PORT_ PIN	MCAN0 _PIN_A ND_TX	-	-	-	-	-	-	-	-	-
		RESSEL (8-15)	-	-	-	-	-	-	-	-	-	-	-
		PORTSE L (0-7)	P1_05	P3_09	P4_00	-	-	-	-	-	-	-	-
		PORTSE L (8-15)	-	-	-	-	-	-	-	-	-	-	-
RIC_RE SIN137 (0x0112)	RX1	RESSEL (0-7)	PORT_ PIN	MCAN1 _PIN_A ND_TX	-	-	-	-	-	-	-	-	-
		RESSEL (8-15)	-	-	-	-	-	-	-	-	-	-	-
		PORTSE L (0-7)	P1_07	P3_11	-	-	-	-	-	-	-	-	-
		PORTSE L (8-15)	-	-	-	-	-	-	-	-	-	-	-
RIC_RE SIN138 (0x0114)	RX2	RESSEL (0-7)	PORT_ PIN	MCAN2 _PIN_A ND_TX	-	-	-	-	-	-	-	-	-
		RESSEL (8-15)	-	-	-	-	-	-	-	-	-	-	-
		PORTSE L (0-7)	P1_11	P3_14	-	-	-	-	-	-	-	-	-
		PORTSE L (8-15)	-	-	-	-	-	-	-	-	-	-	-
RIC_RE SIN139 (0x0116)	RX3	RESSEL (0-7)	PORT_ PIN	MCAN3 _PIN_A ND_TX	-	-	-	-	-	-	-	-	-
		RESSEL (8-15)	-	-	-	-	-	-	-	-	-	-	-
		PORTSE L (0-7)	P1_13	P3_16	P4_03	-	-	-	-	-	-	-	-
		PORTSE L (8-15)	-	-	-	-	-	-	-	-	-	-	-

Register (Offset)	Resource	RESSEL [3:0] /PORT SEL[3:0]	Source for Resource Input							
			0	1	2	3	4	5	6	7
			8	9	10	11	12	13	14	15
RIC_RE SIN141 (0x011A)	TIN48	RESSEL (0-7)	PORT_ PIN	TOT49	RLT49_ UFSET	-	-	-	-	-
		RESSEL (8-15)	-	-	-	-	-	-	-	-
		PORTSE L (0-7)	P1_13	P3_16	-	-	-	-	-	-
		PORTSE L (8-15)	-	-	-	-	-	-	-	-
RIC_RE SIN142 (0x011C)	TIN49	RESSEL (0-7)	PORT_ PIN	TOT48	RLT48_ UFSET	-	-	-	-	-
		RESSEL (8-15)	-	-	-	-	-	-	-	-
		PORTSE L (0-7)	P1_15	P3_20	-	-	-	-	-	-
		PORTSE L (8-15)	-	-	-	-	-	-	-	-
RIC_RE SIN144 (0x0120)	TIN0	RESSEL (0-7)	PORT_ PIN	TOT1	RLT1_ UFSET	-	PPG0_ T OUT0	-	-	-
		RESSEL (8-15)	-	-	-	-	-	-	-	-
		PORTSE L (0-7)	P1_03	P3_08	-	-	-	-	-	-
		PORTSE L (8-15)	-	-	-	-	-	-	-	-
RIC_RE SIN145 (0x0122)	TIN1	RESSEL (0-7)	PORT_ PIN	TOT0	RLT0_ UFSET	-	PPG1_ T OUT0	-	-	-
		RESSEL (8-15)	-	-	-	-	-	-	-	-
		PORTSE L (0-7)	P1_05	P3_10	-	-	-	-	-	-
		PORTSE L (8-15)	-	-	-	-	-	-	-	-
RIC_RE SIN160 (0x0140)	TIN16	RESSEL (0-7)	PORT_ PIN	TOT17	RLT17_ UFSET	-	PPG6_ T OUT0	-	-	-
		RESSEL (8-15)	-	-	-	-	-	-	-	-
		PORTSE L (0-7)	P1_07	P3_12	-	-	-	-	-	-
		PORTSE L (8-15)	-	-	-	-	-	-	-	-

Register (Offset)	Resource	RESSEL [3:0] /PORT SEL[3:0]	Source for Resource Input							
			0	1	2	3	4	5	6	7
			8	9	10	11	12	13	14	15
RIC_RE SIN161 (0x0142)	TIN17	RESSEL (0-7)	PORT_ PIN	TOT16	RLT16_ UFSET	-	PPG7_T OUT0	-	-	-
		RESSEL (8-15)	-	-	-	-	-	-	-	-
		PORTSE L (0-7)	P1_11	P3_14	-	-	-	-	-	-
		PORTSE L (8-15)	-	-	-	-	-	-	-	-
RIC_RE SIN192 (0x0180)	EINT0	RESSEL (0-7)	-	-	-	-	-	-	-	-
		RESSEL (8-15)	-	-	-	-	-	-	-	-
		PORTSE L (0-7)	P2_13	P0_00	P0_08	P0_20	P3_17	P2_01	P2_16	-
		PORTSE L (8-15)	-	-	-	-	-	-	-	-
RIC_RE SIN193 (0x0182)	EINT1	RESSEL (0-7)	-	-	-	-	-	-	-	-
		RESSEL (8-15)	-	-	-	-	-	-	-	-
		PORTSE L (0-7)	P0_01	P3_00	P0_09	P0_22	P4_16	P4_27	P2_17	-
		PORTSE L (8-15)	-	-	-	-	-	-	-	-
RIC_RE SIN194 (0x0184)	EINT2	RESSEL (0-7)	-	-	-	-	-	-	-	-
		RESSEL (8-15)	-	-	-	-	-	-	-	-
		PORTSE L (0-7)	P0_21	P4_30	P4_03	P0_23	P3_20	P2_02	P2_18	-
		PORTSE L (8-15)	-	-	-	-	-	-	-	-
RIC_RE SIN195 (0x0186)	EINT3	RESSEL (0-7)	-	-	-	-	-	-	-	-
		RESSEL (8-15)	-	-	-	-	-	-	-	-
		PORTSE L (0-7)	P0_28	P3_28	P4_04	P0_24	P3_21	P2_03	P2_19	-
		PORTSE L (8-15)	-	-	-	-	-	-	-	-

Register (Offset)	Resource	RESSEL [3:0] /PORT SEL[3:0]	Source for Resource Input							
			0	1	2	3	4	5	6	7
			8	9	10	11	12	13	14	15
RIC_RE SIN196 (0x0188)	EINT4	RESSEL (0-7)	-	-	-	-	-	-	-	-
		RESSEL (8-15)	-	-	-	-	-	-	-	-
		PORTSE L (0-7)	P1_03	P0_02	P4_05	P0_25	P3_23	P2_04	-	-
		PORTSE L (8-15)	-	-	-	-	-	-	-	-
RIC_RE SIN197 (0x018A)	EINT5	RESSEL (0-7)	-	-	-	-	-	-	-	-
		RESSEL (8-15)	-	-	-	-	-	-	-	-
		PORTSE L (0-7)	P1_04	P0_03	P0_10	P0_26	P4_17	P4_28	-	-
		PORTSE L (8-15)	-	-	-	-	-	-	-	-
RIC_RE SIN198 (0x018C)	EINT6	RESSEL (0-7)	-	-	-	-	-	-	-	-
		RESSEL (8-15)	-	-	-	-	-	-	-	-
		PORTSE L (0-7)	P1_05	P3_09	P0_11	P0_27	P4_18	P2_06	-	-
		PORTSE L (8-15)	-	-	-	-	-	-	-	-
RIC_RE SIN199 (0x018E)	EINT7	RESSEL (0-7)	-	-	-	-	-	-	-	-
		RESSEL (8-15)	-	-	-	-	-	-	-	-
		PORTSE L (0-7)	P1_06	P4_00	P0_12	P0_29	P4_20	P2_07	-	-
		PORTSE L (8-15)	-	-	-	-	-	-	-	-
RIC_RE SIN200 (0x0190)	EINT8	RESSEL (0-7)	-	-	-	-	-	-	-	-
		RESSEL (8-15)	-	-	-	-	-	-	-	-
		PORTSE L (0-7)	P1_07	P3_11	P0_13	P0_30	P4_21	P4_29	-	-
		PORTSE L (8-15)	-	-	-	-	-	-	-	-

Register (Offset)	Resource	RESSEL [3:0] /PORT SEL[3:0]	Source for Resource Input									
			0	1	2	3	4	5	6	7		
			8	9	10	11	12	13	14	15		
RIC_RE SIN201 (0x0192)	EINT9	RESSEL (0-7)	-	-	-	-	-	-	-	-	-	
		RESSEL (8-15)	-	-	-	-	-	-	-	-	-	
		PORTSE L (0-7)	P1_08	P4_01	P3_01	P0_31	P1_16	P2_08	-	-	-	
		PORTSE L (8-15)	-	-	-	-	-	-	-	-	-	
RIC_RE SIN202 (0x0194)	EINT10	RESSEL (0-7)	-	-	-	-	-	-	-	-	-	
		RESSEL (8-15)	-	-	-	-	-	-	-	-	-	
		PORTSE L (0-7)	P1_09	P4_02	P3_02	P1_00	P4_23	P4_31	-	-	-	
		PORTSE L (8-15)	-	-	-	-	-	-	-	-	-	
RIC_RE SIN203 (0x0196)	EINT11	RESSEL (0-7)	-	-	-	-	-	-	-	-	-	
		RESSEL (8-15)	-	-	-	-	-	-	-	-	-	
		PORTSE L (0-7)	P1_10	P0_04	P3_03	P1_01	P1_18	P3_24	-	-	-	
		PORTSE L (8-15)	-	-	-	-	-	-	-	-	-	
RIC_RE SIN204 (0x0198)	EINT12	RESSEL (0-7)	-	-	-	-	-	-	-	-	-	
		RESSEL (8-15)	-	-	-	-	-	-	-	-	-	
		PORTSE L (0-7)	P1_11	P3_14	P3_04	P1_02	P1_20	P3_25	-	-	-	
		PORTSE L (8-15)	-	-	-	-	-	-	-	-	-	
RIC_RE SIN205 (0x019A)	EINT13	RESSEL (0-7)	-	-	-	-	-	-	-	-	-	
		RESSEL (8-15)	-	-	-	-	-	-	-	-	-	
		PORTSE L (0-7)	P1_12	P0_05	P4_06	P4_08	P1_22	P3_26	-	-	-	
		PORTSE L (8-15)	-	-	-	-	-	-	-	-	-	

Register (Offset)	Resource	RESSEL [3:0] /PORT SEL[3:0]	Source for Resource Input							
			0	1	2	3	4	5	6	7
			8	9	10	11	12	13	14	15
RIC_RE SIN206 (0x019C)	EINT14	RESSEL (0-7)	-	-	-	-	-	-	-	-
		RESSEL (8-15)	-	-	-	-	-	-	-	-
		PORTSE L (0-7)	P1_13	P3_16	P4_07	P4_09	P1_24	P3_27	-	-
		PORTSE L (8-15)	-	-	-	-	-	-	-	-
RIC_RE SIN207 (0x019E)	EINT15	RESSEL (0-7)	-	-	-	-	-	-	-	-
		RESSEL (8-15)	-	-	-	-	-	-	-	-
		PORTSE L (0-7)	P1_14	P0_06	P3_05	P4_10	P1_25	P2_09	-	-
		PORTSE L (8-15)	-	-	-	-	-	-	-	-
RIC_RE SIN208 (0x01A0)	EINT16	RESSEL (0-7)	-	-	-	-	-	-	-	-
		RESSEL (8-15)	-	-	-	-	-	-	-	-
		PORTSE L (0-7)	P1_15	P4_19	P3_06	P4_11	P4_24	P3_29	-	-
		PORTSE L (8-15)	-	-	-	-	-	-	-	-
RIC_RE SIN209 (0x01A2)	EINT17	RESSEL (0-7)	-	-	-	-	-	-	-	-
		RESSEL (8-15)	-	-	-	-	-	-	-	-
		PORTSE L (0-7)	P1_17	P3_19	P0_14	P3_10	P1_26	P3_30	-	-
		PORTSE L (8-15)	-	-	-	-	-	-	-	-
RIC_RE SIN210 (0x01A4)	EINT18	RESSEL (0-7)	-	-	-	-	-	-	-	-
		RESSEL (8-15)	-	-	-	-	-	-	-	-
		PORTSE L (0-7)	P1_19	P3_08	P0_15	P3_13	P1_27	P3_31	-	-
		PORTSE L (8-15)	-	-	-	-	-	-	-	-

Register (Offset)	Resource	RESSEL [3:0] /PORT SEL[3:0]	Source for Resource Input							
			0	1	2	3	4	5	6	7
			8	9	10	11	12	13	14	15
RIC_RE SIN211 (0x01A6)	EINT19	RESSEL (0-7)	-	-	-	-	-	-	-	-
		RESSEL (8-15)	-	-	-	-	-	-	-	-
		PORTSE L (0-7)	P1_21	P3_22	P0_16	P3_15	P4_25	P2_10	-	-
		PORTSE L (8-15)	-	-	-	-	-	-	-	-
RIC_RE SIN212 (0x01A8)	EINT20	RESSEL (0-7)	-	-	-	-	-	-	-	-
		RESSEL (8-15)	-	-	-	-	-	-	-	-
		PORTSE L (0-7)	P1_23	P3_18	P3_07	P4_12	P1_29	P2_11	-	-
		PORTSE L (8-15)	-	-	-	-	-	-	-	-
RIC_RE SIN213 (0x01AA)	EINT21	RESSEL (0-7)	-	-	-	-	-	-	-	-
		RESSEL (8-15)	-	-	-	-	-	-	-	-
		PORTSE L (0-7)	P1_28	P3_12	P0_17	P4_13	P1_30	P2_12	-	-
		PORTSE L (8-15)	-	-	-	-	-	-	-	-
RIC_RE SIN214 (0x01AC)	EINT22	RESSEL (0-7)	-	-	-	-	-	-	-	-
		RESSEL (8-15)	-	-	-	-	-	-	-	-
		PORTSE L (0-7)	P2_00	P4_22	P0_18	P4_14	P1_31	P2_14	-	-
		PORTSE L (8-15)	-	-	-	-	-	-	-	-
RIC_RE SIN215 (0x01AE)	EINT23	RESSEL (0-7)	-	-	-	-	-	-	-	-
		RESSEL (8-15)	-	-	-	-	-	-	-	-
		PORTSE L (0-7)	P2_05	P0_07	P0_19	P4_15	P4_26	P2_15	-	-
		PORTSE L (8-15)	-	-	-	-	-	-	-	-

Register (Offset)	Resource	RESSEL [3:0] /PORT SEL[3:0]	Source for Resource Input							
			0	1	2	3	4	5	6	7
			8	9	10	11	12	13	14	15
RIC_RE SIN216 (0x01B0)	TEXT0	RESSEL (0-7)	PORT_ PIN	TOT0	TOT1	PPG0_T OUT2	-	-	-	-
		RESSEL (8-15)	-	-	-	-	-	-	-	-
		PORTSE L (0-7)	-	-	-	-	-	-	-	-
		PORTSE L (8-15)	-	-	-	-	-	-	-	-
RIC_RE SIN217 (0x01B2)	TEXT1	RESSEL (0-7)	PORT_ PIN	TOT0	TOT1	PPG1_T OUT2	-	-	-	-
		RESSEL (8-15)	-	-	-	-	-	-	-	-
		PORTSE L (0-7)	-	-	-	-	-	-	-	-
		PORTSE L (8-15)	-	-	-	-	-	-	-	-
RIC_RE SIN218 (0x01B4)	TEXT2	RESSEL (0-7)	PORT_ PIN	TOT0	TOT1	PPG2_T OUT2	-	-	-	-
		RESSEL (8-15)	-	-	-	-	-	-	-	-
		PORTSE L (0-7)	-	-	-	-	-	-	-	-
		PORTSE L (8-15)	-	-	-	-	-	-	-	-
RIC_RE SIN219 (0x01B6)	TEXT3	RESSEL (0-7)	PORT_ PIN	TOT0	TOT1	PPG3_T OUT2	-	-	-	-
		RESSEL (8-15)	-	-	-	-	-	-	-	-
		PORTSE L (0-7)	-	-	-	-	-	-	-	-
		PORTSE L (8-15)	-	-	-	-	-	-	-	-
RIC_RE SIN220 (0x01B8)	TEXT4	RESSEL (0-7)	PORT_ PIN	TOT0	TOT1	PPG4_T OUT2	-	-	-	-
		RESSEL (8-15)	-	-	-	-	-	-	-	-
		PORTSE L (0-7)	-	-	-	-	-	-	-	-
		PORTSE L (8-15)	-	-	-	-	-	-	-	-



Register (Offset)	Resource	RESSEL [3:0] /PORT SEL[3:0]	Source for Resource Input							
			0	1	2	3	4	5	6	7
			8	9	10	11	12	13	14	15
RIC_RE SIN224 (0x01C0)	TEXT8	RESSEL (0-7)	PORT_ PIN	RLT0_U FSET	RLT16_ UFSET	PPG6_T OUT2	-	-	-	-
		RESSEL (8-15)	-	-	-	-	-	-	-	-
		PORTSE L (0-7)	-	-	-	-	-	-	-	-
		PORTSE L (8-15)	-	-	-	-	-	-	-	-
RIC_RE SIN225 (0x01C2)	TEXT9	RESSEL (0-7)	PORT_ PIN	RLT0_U FSET	RLT16_ UFSET	PPG7_T OUT2	-	-	-	-
		RESSEL (8-15)	-	-	-	-	-	-	-	-
		PORTSE L (0-7)	-	-	-	-	-	-	-	-
		PORTSE L (8-15)	-	-	-	-	-	-	-	-
RIC_RE SIN226 (0x01C4)	TEXT10	RESSEL (0-7)	PORT_ PIN	RLT0_U FSET	RLT16_ UFSET	PPG8_T OUT2	-	-	-	-
		RESSEL (8-15)	-	-	-	-	-	-	-	-
		PORTSE L (0-7)	-	-	-	-	-	-	-	-
		PORTSE L (8-15)	-	-	-	-	-	-	-	-

Register (Offset)	Resource	RESSEL [3:0] /PORT SEL[3:0]	Source for Resource Input							
			0	1	2	3	4	5	6	7
			8	9	10	11	12	13	14	15
IN232 (0x01D0)	OCU0_C K0	RESSEL (0-7)	FRT0	FRT1	FRT2	FRT3	FRT4	-	-	-
		RESSEL (8-15)	-	-	-	-	-	-	-	-
		PORTSE L (0-7)	-	-	-	-	-	-	-	-
		PORTSE L (8-15)	-	-	-	-	-	-	-	-
	OCU0_CK 1	RESSEL (0-7)	FRT0	FRT1	FRT2	FRT3	FRT4	-	-	-
		RESSEL (8-15)	-	-	-	-	-	-	-	-
		PORTSE L (0-7)	-	-	-	-	-	-	-	-
		PORTSE L (8-15)	-	-	-	-	-	-	-	-
	OCU0_D OWNB0	RESSEL (0-7)	FRT0_D OWNB	FRT1_D OWNB	FRT2_D OWNB	FRT3_D OWNB	FRT4_D OWNB	-	-	-
		RESSEL (8-15)	-	-	-	-	-	-	-	-
		PORTSE L (0-7)	-	-	-	-	-	-	-	-
		PORTSE L (8-15)	-	-	-	-	-	-	-	-
	OCU0_D OWNB1	RESSEL (0-7)	FRT0_D OWNB	FRT1_D OWNB	FRT2_D OWNB	FRT3_D OWNB	FRT4_D OWNB	-	-	-
		RESSEL (8-15)	-	-	-	-	-	-	-	-
		PORTSE L (0-7)	-	-	-	-	-	-	-	-
		PORTSE L (8-15)	-	-	-	-	-	-	-	-
	OCU0_FC MD0	RESSEL (0-7)	FRT0_F CMD	FRT1_F CMD	FRT2_F CMD	FRT3_F CMD	FRT4_F CMD	-	-	-
		RESSEL (8-15)	-	-	-	-	-	-	-	-
		PORTSE L (0-7)	-	-	-	-	-	-	-	-
		PORTSE L (8-15)	-	-	-	-	-	-	-	-

Register (Offset)	Resource	RESSEL [3:0] /PORT SEL[3:0]	Source for Resource Input							
			0	1	2	3	4	5	6	7
			8	9	10	11	12	13	14	15
IN232 (0x01D0)	OCU0_FC MD1	RESSEL (0-7)	FRT0_F CMD	FRT1_F CMD	FRT2_F CMD	FRT3_F CMD	FRT4_F CMD	-	-	-
		RESSEL (8-15)	-	-	-	-	-	-	-	-
		PORTSE L (0-7)	-	-	-	-	-	-	-	-
		PORTSE L (8-15)	-	-	-	-	-	-	-	-
	OCU0_MT SF0	RESSEL (0-7)	FRT0_M TSF	FRT1_M TSF	FRT2_M TSF	FRT3_M TSF	FRT4_M TSF	-	-	-
		RESSEL (8-15)	-	-	-	-	-	-	-	-
		PORTSE L (0-7)	-	-	-	-	-	-	-	-
		PORTSE L (8-15)	-	-	-	-	-	-	-	-
	OCU0_MT SF1	RESSEL (0-7)	FRT0_M TSF	FRT1_M TSF	FRT2_M TSF	FRT3_M TSF	FRT4_M TSF	-	-	-
		RESSEL (8-15)	-	-	-	-	-	-	-	-
		PORTSE L (0-7)	-	-	-	-	-	-	-	-
		PORTSE L (8-15)	-	-	-	-	-	-	-	-
	OCU0_T0[ 31:0]	RESSEL (0-7)	FRT0_T [31:0]	FRT1_T [31:0]	FRT2_T [31:0]	FRT3_T [31:0]	FRT4_T [31:0]	-	-	-
		RESSEL (8-15)	-	-	-	-	-	-	-	-
		PORTSE L (0-7)	-	-	-	-	-	-	-	-
		PORTSE L (8-15)	-	-	-	-	-	-	-	-
	OCU0_T1[ 31:0]	RESSEL (0-7)	FRT0_T [31:0]	FRT1_T [31:0]	FRT2_T [31:0]	FRT3_T [31:0]	FRT4_T [31:0]	-	-	-
		RESSEL (8-15)	-	-	-	-	-	-	-	-
		PORTSE L (0-7)	-	-	-	-	-	-	-	-
		PORTSE L (8-15)	-	-	-	-	-	-	-	-

Register (Offset)	Resource	RESSEL [3:0] /PORT SEL[3:0]	Source for Resource Input							
			0	1	2	3	4	5	6	7
			8	9	10	11	12	13	14	15
IN232 (0x01D0)	OCU0_ZT SF0	RESSEL (0-7)	FRT0_Z TSF	FRT1_Z TSF	FRT2_Z TSF	FRT3_Z TSF	FRT4_Z TSF	-	-	-
		RESSEL (8-15)	-	-	-	-	-	-	-	-
		PORTSE L (0-7)	-	-	-	-	-	-	-	-
		PORTSE L (8-15)	-	-	-	-	-	-	-	-
	OCU0_ZT SF1	RESSEL (0-7)	FRT0_Z TSF	FRT1_Z TSF	FRT2_Z TSF	FRT3_Z TSF	FRT4_Z TSF	-	-	-
		RESSEL (8-15)	-	-	-	-	-	-	-	-
		PORTSE L (0-7)	-	-	-	-	-	-	-	-
		PORTSE L (8-15)	-	-	-	-	-	-	-	-
RIC_RE SIN233 (0x01D2)	OCU0_M OD0	RESSEL (0-7)	set 1	set 0	-	-	-	-	-	
		RESSEL (8-15)	-	-	-	-	-	-	-	
		PORTSE L (0-7)	-	-	-	-	-	-	-	
		PORTSE L (8-15)	-	-	-	-	-	-	-	
RIC_RE SIN234 (0x01D4)	OCU0_M OD1	RESSEL (0-7)	set 1	set 0	-	-	-	-	-	
		RESSEL (8-15)	-	-	-	-	-	-	-	
		PORTSE L (0-7)	-	-	-	-	-	-	-	
		PORTSE L (8-15)	-	-	-	-	-	-	-	
RIC_RE SIN235 (0x01D6)	OCU1_CK 0	RESSEL (0-7)	FRT0	FRT1	FRT2	FRT3	FRT4	-	-	
		RESSEL (8-15)	-	-	-	-	-	-	-	
		PORTSE L (0-7)	-	-	-	-	-	-	-	
		PORTSE L (8-15)	-	-	-	-	-	-	-	

Register (Offset)	Resource	RESSEL [3:0] /PORT SEL[3:0]	Source for Resource Input							
			0	1	2	3	4	5	6	7
			8	9	10	11	12	13	14	15
RIC_RE SIN235 (0x01D6)	OCU1_CK 1	RESSEL (0-7)	FRT0	FRT1	FRT2	FRT3	FRT4	-	-	-
		RESSEL (8-15)	-	-	-	-	-	-	-	-
		PORTSE L (0-7)	-	-	-	-	-	-	-	-
		PORTSE L (8-15)	-	-	-	-	-	-	-	-
	OCU1_D OWNB0	RESSEL (0-7)	FRT0_D OWNB	FRT1_D OWNB	FRT2_D OWNB	FRT3_D OWNB	FRT4_D OWNB	-	-	-
		RESSEL (8-15)	-	-	-	-	-	-	-	-
		PORTSE L (0-7)	-	-	-	-	-	-	-	-
		PORTSE L (8-15)	-	-	-	-	-	-	-	-
	OCU1_D OWNB1	RESSEL (0-7)	FRT0_D OWNB	FRT1_D OWNB	FRT2_D OWNB	FRT3_D OWNB	FRT4_D OWNB	-	-	-
		RESSEL (8-15)	-	-	-	-	-	-	-	-
		PORTSE L (0-7)	-	-	-	-	-	-	-	-
		PORTSE L (8-15)	-	-	-	-	-	-	-	-
	OCU1_FC MD0	RESSEL (0-7)	FRT0_F CMD	FRT1_F CMD	FRT2_F CMD	FRT3_F CMD	FRT4_F CMD	-	-	-
		RESSEL (8-15)	-	-	-	-	-	-	-	-
		PORTSE L (0-7)	-	-	-	-	-	-	-	-
		PORTSE L (8-15)	-	-	-	-	-	-	-	-
	OCU1_FC MD1	RESSEL (0-7)	FRT0_F CMD	FRT1_F CMD	FRT2_F CMD	FRT3_F CMD	FRT4_F CMD	-	-	-
		RESSEL (8-15)	-	-	-	-	-	-	-	-
		PORTSE L (0-7)	-	-	-	-	-	-	-	-
		PORTSE L (8-15)	-	-	-	-	-	-	-	-

Register (Offset)	Resource	RESSEL [3:0] /PORT SEL[3:0]	Source for Resource Input							
			0	1	2	3	4	5	6	7
			8	9	10	11	12	13	14	15
RIC_RE SIN235 (0x01D6)	OCU1_MT SF0	RESSEL (0-7)	FRT0_M TSF	FRT1_M TSF	FRT2_M TSF	FRT3_M TSF	FRT4_M TSF	-	-	-
		RESSEL (8-15)	-	-	-	-	-	-	-	-
		PORTSE L (0-7)	-	-	-	-	-	-	-	-
		PORTSE L (8-15)	-	-	-	-	-	-	-	-
	OCU1_MT SF1	RESSEL (0-7)	FRT0_M TSF	FRT1_M TSF	FRT2_M TSF	FRT3_M TSF	FRT4_M TSF	-	-	-
		RESSEL (8-15)	-	-	-	-	-	-	-	-
		PORTSE L (0-7)	-	-	-	-	-	-	-	-
		PORTSE L (8-15)	-	-	-	-	-	-	-	-
	OCU1_T0[ 31:0]	RESSEL (0-7)	FRT0_T [31:0]	FRT1_T [31:0]	FRT2_T [31:0]	FRT3_T [31:0]	FRT4_T [31:0]	-	-	-
		RESSEL (8-15)	-	-	-	-	-	-	-	-
		PORTSE L (0-7)	-	-	-	-	-	-	-	-
		PORTSE L (8-15)	-	-	-	-	-	-	-	-
	OCU1_T1[ 31:0]	RESSEL (0-7)	FRT0_T [31:0]	FRT1_T [31:0]	FRT2_T [31:0]	FRT3_T [31:0]	FRT4_T [31:0]	-	-	-
		RESSEL (8-15)	-	-	-	-	-	-	-	-
		PORTSE L (0-7)	-	-	-	-	-	-	-	-
		PORTSE L (8-15)	-	-	-	-	-	-	-	-

Register (Offset)	Resource	RESSEL [3:0] /PORT SEL[3:0]	Source for Resource Input							
			0	1	2	3	4	5	6	7
			8	9	10	11	12	13	14	15
RIC_RE SIN235 (0x01D6)	OCU1_ZT SF0	RESSEL (0-7)	FRT0_Z TSF	FRT1_Z TSF	FRT2_Z TSF	FRT3_Z TSF	FRT4_Z TSF	-	-	-
		RESSEL (8-15)	-	-	-	-	-	-	-	-
		PORTSE L (0-7)	-	-	-	-	-	-	-	-
		PORTSE L (8-15)	-	-	-	-	-	-	-	-
	OCU1_ZT SF1	RESSEL (0-7)	FRT0_Z TSF	FRT1_Z TSF	FRT2_Z TSF	FRT3_Z TSF	FRT4_Z TSF	-	-	-
		RESSEL (8-15)	-	-	-	-	-	-	-	-
		PORTSE L (0-7)	-	-	-	-	-	-	-	-
		PORTSE L (8-15)	-	-	-	-	-	-	-	-
RIC_RE SIN236 (0x01D8)	OCU1_M OD0	RESSEL (0-7)	set 1	set 0	-	-	-	-	-	
		RESSEL (8-15)	-	-	-	-	-	-	-	
		PORTSE L (0-7)	-	-	-	-	-	-	-	
		PORTSE L (8-15)	-	-	-	-	-	-	-	
RIC_RE SIN237 (0x01DA)	OCU1_M OD1	RESSEL (0-7)	set 1	set 0	-	-	-	-	-	
		RESSEL (8-15)	-	-	-	-	-	-	-	
		PORTSE L (0-7)	-	-	-	-	-	-	-	
		PORTSE L (8-15)	-	-	-	-	-	-	-	

Register (Offset)	Resource	RESSEL [3:0] /PORT SEL[3:0]	Source for Resource Input							
			0	1	2	3	4	5	6	7
			8	9	10	11	12	13	14	15
RIC_RE SIN238 (0x01DC)	OCU2_CK 0	RESSEL (0-7)	FRT0	FRT1	FRT2	FRT3	FRT4	-	-	-
		RESSEL (8-15)	-	-	-	-	-	-	-	-
		PORTSE L (0-7)	-	-	-	-	-	-	-	-
		PORTSE L (8-15)	-	-	-	-	-	-	-	-
	OCU2_CK 1	RESSEL (0-7)	FRT0	FRT1	FRT2	FRT3	FRT4	-	-	-
		RESSEL (8-15)	-	-	-	-	-	-	-	-
		PORTSE L (0-7)	-	-	-	-	-	-	-	-
		PORTSE L (8-15)	-	-	-	-	-	-	-	-
	OCU2_D OWNB0	RESSEL (0-7)	FRT0_D OWNB	FRT1_D OWNB	FRT2_D OWNB	FRT3_D OWNB	FRT4_D OWNB	-	-	-
		RESSEL (8-15)	-	-	-	-	-	-	-	-
		PORTSE L (0-7)	-	-	-	-	-	-	-	-
		PORTSE L (8-15)	-	-	-	-	-	-	-	-



Register (Offset)	Resource	RESSEL [3:0] /PORT SEL[3:0]	Source for Resource Input							
			0	1	2	3	4	5	6	7
			8	9	10	11	12	13	14	15
RIC_RE SIN238 (0x01DC)	OCU2_D OWNB1	RESSEL (0-7)	FRT0_D OWNB	FRT1_D OWNB	FRT2_D OWNB	FRT3_D OWNB	FRT4_D OWNB	-	-	-
		RESSEL (8-15)	-	-	-	-	-	-	-	-
		PORTSE L (0-7)	-	-	-	-	-	-	-	-
		PORTSE L (8-15)	-	-	-	-	-	-	-	-
	OCU2_FC MD0	RESSEL (0-7)	FRT0_F CMD	FRT1_F CMD	FRT2_F CMD	FRT3_F CMD	FRT4_F CMD	-	-	-
		RESSEL (8-15)	-	-	-	-	-	-	-	-
		PORTSE L (0-7)	-	-	-	-	-	-	-	-
		PORTSE L (8-15)	-	-	-	-	-	-	-	-
	OCU2_FC MD1	RESSEL (0-7)	FRT0_F CMD	FRT1_F CMD	FRT2_F CMD	FRT3_F CMD	FRT4_F CMD	-	-	-
		RESSEL (8-15)	-	-	-	-	-	-	-	-
		PORTSE L (0-7)	-	-	-	-	-	-	-	-
		PORTSE L (8-15)	-	-	-	-	-	-	-	-
	OCU2_MT SF0	RESSEL (0-7)	FRT0_M TSF	FRT1_M TSF	FRT2_M TSF	FRT3_M TSF	FRT4_M TSF	-	-	-
		RESSEL (8-15)	-	-	-	-	-	-	-	-
		PORTSE L (0-7)	-	-	-	-	-	-	-	-
		PORTSE L (8-15)	-	-	-	-	-	-	-	-
	OCU2_MT SF1	RESSEL (0-7)	FRT0_M TSF	FRT1_M TSF	FRT2_M TSF	FRT3_M TSF	FRT4_M TSF	-	-	-
		RESSEL (8-15)	-	-	-	-	-	-	-	-
		PORTSE L (0-7)	-	-	-	-	-	-	-	-
		PORTSE L (8-15)	-	-	-	-	-	-	-	-

Register (Offset)	Resource	RESSEL [3:0] /PORT SEL[3:0]	Source for Resource Input							
			0	1	2	3	4	5	6	7
			8	9	10	11	12	13	14	15
RIC_RE SIN238 (0x01DC)	OCU2_T0[ 31:0]	RESSEL (0-7)	FRT0_T [31:0]	FRT1_T [31:0]	FRT2_T [31:0]	FRT3_T [31:0]	FRT4_T [31:0]	-	-	-
		RESSEL (8-15)	-	-	-	-	-	-	-	-
		PORTSE L (0-7)	-	-	-	-	-	-	-	-
		PORTSE L (8-15)	-	-	-	-	-	-	-	-
	OCU2_T1[ 31:0]	RESSEL (0-7)	FRT0_T [31:0]	FRT1_T [31:0]	FRT2_T [31:0]	FRT3_T [31:0]	FRT4_T [31:0]	-	-	-
		RESSEL (8-15)	-	-	-	-	-	-	-	-
		PORTSE L (0-7)	-	-	-	-	-	-	-	-
		PORTSE L (8-15)	-	-	-	-	-	-	-	-
	OCU2_ZT SF0	RESSEL (0-7)	FRT0_Z TSF	FRT1_Z TSF	FRT2_Z TSF	FRT3_Z TSF	FRT4_Z TSF	-	-	-
		RESSEL (8-15)	-	-	-	-	-	-	-	-
		PORTSE L (0-7)	-	-	-	-	-	-	-	-
		PORTSE L (8-15)	-	-	-	-	-	-	-	-
	OCU2_ZT SF1	RESSEL (0-7)	FRT0_Z TSF	FRT1_Z TSF	FRT2_Z TSF	FRT3_Z TSF	FRT4_Z TSF	-	-	-
		RESSEL (8-15)	-	-	-	-	-	-	-	-
		PORTSE L (0-7)	-	-	-	-	-	-	-	-
		PORTSE L (8-15)	-	-	-	-	-	-	-	-

Register (Offset)	Resource	RESSEL [3:0] /PORT SEL[3:0]	Source for Resource Input										
			0	1	2	3	4	5	6	7			
			8	9	10	11	12	13	14	15			
RIC_RE SIN239 (0x01DE)	OCU2_M OD0	RESSEL (0-7)	set 1	set 0	-	-	-	-	-	-	-	-	-
		RESSEL (8-15)	-	-	-	-	-	-	-	-	-	-	-
		PORTSE L (0-7)	-	-	-	-	-	-	-	-	-	-	-
		PORTSE L (8-15)	-	-	-	-	-	-	-	-	-	-	-
RIC_RE SIN240 (0x01E0)	OCU2_M OD1	RESSEL (0-7)	set 1	set 0	-	-	-	-	-	-	-	-	-
		RESSEL (8-15)	-	-	-	-	-	-	-	-	-	-	-
		PORTSE L (0-7)	-	-	-	-	-	-	-	-	-	-	-
		PORTSE L (8-15)	-	-	-	-	-	-	-	-	-	-	-

Register (Offset)	Resource	RESSEL [3:0] /PORT SEL[3:0]	Source for Resource Input							
			0	1	2	3	4	5	6	7
			8	9	10	11	12	13	14	15
RIC_RE SIN256 (0x0200)	OCU8_CK 0	RESSEL (0-7)	FRT8	FRT9	FRT10	-	-	-	-	-
		RESSEL (8-15)	-	-	-	-	-	-	-	-
		PORTSE L (0-7)	-	-	-	-	-	-	-	-
		PORTSE L (8-15)	-	-	-	-	-	-	-	-
	OCU8_CK 1	RESSEL (0-7)	FRT8	FRT9	FRT10	-	-	-	-	-
		RESSEL (8-15)	-	-	-	-	-	-	-	-
		PORTSE L (0-7)	-	-	-	-	-	-	-	-
		PORTSE L (8-15)	-	-	-	-	-	-	-	-
	OCU8_D OWNB0	RESSEL (0-7)	FRT8_D OWNB	FRT9_D OWNB	FRT10_ DOWNB	-	-	-	-	-
		RESSEL (8-15)	-	-	-	-	-	-	-	-
		PORTSE L (0-7)	-	-	-	-	-	-	-	-
		PORTSE L (8-15)	-	-	-	-	-	-	-	-
	OCU8_D OWNB1	RESSEL (0-7)	FRT8_D OWNB	FRT9_D OWNB	FRT10_ DOWNB	-	-	-	-	-
		RESSEL (8-15)	-	-	-	-	-	-	-	-
		PORTSE L (0-7)	-	-	-	-	-	-	-	-
		PORTSE L (8-15)	-	-	-	-	-	-	-	-
	OCU8_FC MD0	RESSEL (0-7)	FRT8_F CMD	FRT9_F CMD	FRT10_ FCMD	-	-	-	-	-
		RESSEL (8-15)	-	-	-	-	-	-	-	-
		PORTSE L (0-7)	-	-	-	-	-	-	-	-
		PORTSE L (8-15)	-	-	-	-	-	-	-	-

Register (Offset)	Resource	RESSEL [3:0] /PORT SEL[3:0]	Source for Resource Input							
			0	1	2	3	4	5	6	7
			8	9	10	11	12	13	14	15
RIC_RE SIN256 (0x0200)	OCU8_FC MD1	RESSEL (0-7)	FRT8_F CMD	FRT9_F CMD	FRT10_ FCMD	-	-	-	-	-
		RESSEL (8-15)	-	-	-	-	-	-	-	-
		PORTSE L (0-7)	-	-	-	-	-	-	-	-
		PORTSE L (8-15)	-	-	-	-	-	-	-	-
	OCU8_MT SF0	RESSEL (0-7)	FRT8_M TSF	FRT9_M TSF	FRT10_ MTSF	-	-	-	-	-
		RESSEL (8-15)	-	-	-	-	-	-	-	-
		PORTSE L (0-7)	-	-	-	-	-	-	-	-
		PORTSE L (8-15)	-	-	-	-	-	-	-	-
	OCU8_MT SF1	RESSEL (0-7)	FRT8_M TSF	FRT9_M TSF	FRT10_ MTSF	-	-	-	-	-
		RESSEL (8-15)	-	-	-	-	-	-	-	-
		PORTSE L (0-7)	-	-	-	-	-	-	-	-
		PORTSE L (8-15)	-	-	-	-	-	-	-	-
	OCU8_T0[ 31:0]	RESSEL (0-7)	FRT8_T [31:0]	FRT9_T [31:0]	FRT10_ T[31:0]	-	-	-	-	-
		RESSEL (8-15)	-	-	-	-	-	-	-	-
		PORTSE L (0-7)	-	-	-	-	-	-	-	-
		PORTSE L (8-15)	-	-	-	-	-	-	-	-
	OCU8_T1[ 31:0]	RESSEL (0-7)	FRT8_T [31:0]	FRT9_T [31:0]	FRT10_ T[31:0]	-	-	-	-	-
		RESSEL (8-15)	-	-	-	-	-	-	-	-
		PORTSE L (0-7)	-	-	-	-	-	-	-	-
		PORTSE L (8-15)	-	-	-	-	-	-	-	-

Register (Offset)	Resource	RESSEL [3:0] /PORT SEL[3:0]	Source for Resource Input							
			0	1	2	3	4	5	6	7
			8	9	10	11	12	13	14	15
RIC_RE SIN256 (0x0200)	OCU8_ZT SF0	RESSEL (0-7)	FRT8_Z TSF	FRT9_Z TSF	FRT10_ ZTSF	-	-	-	-	-
		RESSEL (8-15)	-	-	-	-	-	-	-	-
		PORTSE L (0-7)	-	-	-	-	-	-	-	-
		PORTSE L (8-15)	-	-	-	-	-	-	-	-
	OCU8_ZT SF1	RESSEL (0-7)	FRT8_Z TSF	FRT9_Z TSF	FRT10_ ZTSF	-	-	-	-	-
		RESSEL (8-15)	-	-	-	-	-	-	-	-
		PORTSE L (0-7)	-	-	-	-	-	-	-	-
		PORTSE L (8-15)	-	-	-	-	-	-	-	-
RIC_RE SIN257 (0x0202)	OCU8_M OD0	RESSEL (0-7)	set 1	set 0	-	-	-	-	-	
		RESSEL (8-15)	-	-	-	-	-	-	-	
		PORTSE L (0-7)	-	-	-	-	-	-	-	
		PORTSE L (8-15)	-	-	-	-	-	-	-	

Register (Offset)	Resource	RESSEL [3:0] /PORT SEL[3:0]	Source for Resource Input							
			0	1	2	3	4	5	6	7
			8	9	10	11	12	13	14	15
RIC_RE SIN258 (0x0204)	OCU8_M OD1	RESSEL (0-7)	set 1	set 0	-	-	-	-	-	-
		RESSEL (8-15)	-	-	-	-	-	-	-	-
		PORTSE L (0-7)	-	-	-	-	-	-	-	-
		PORTSE L (8-15)	-	-	-	-	-	-	-	-
RIC_RE SIN259 (0x0206)	OCU9_CK 0	RESSEL (0-7)	FRT8	FRT9	FRT10	-	-	-	-	-
		RESSEL (8-15)	-	-	-	-	-	-	-	-
		PORTSE L (0-7)	-	-	-	-	-	-	-	-
		PORTSE L (8-15)	-	-	-	-	-	-	-	-
	OCU9_CK 1	RESSEL (0-7)	FRT8	FRT9	FRT10	-	-	-	-	-
		RESSEL (8-15)	-	-	-	-	-	-	-	-
		PORTSE L (0-7)	-	-	-	-	-	-	-	-
		PORTSE L (8-15)	-	-	-	-	-	-	-	-

Register (Offset)	Resource	RESSEL [3:0] /PORT SEL[3:0]	Source for Resource Input							
			0	1	2	3	4	5	6	7
			8	9	10	11	12	13	14	15
RIC_RE SIN259 (0x0206)	OCU9_D OWNB0	RESSEL (0-7)	FRT8_D OWNB	FRT9_D OWNB	FRT10_ DOWNB	-	-	-	-	-
		RESSEL (8-15)	-	-	-	-	-	-	-	-
		PORTSE L (0-7)	-	-	-	-	-	-	-	-
		PORTSE L (8-15)	-	-	-	-	-	-	-	-
	OCU9_D OWNB1	RESSEL (0-7)	FRT8_D OWNB	FRT9_D OWNB	FRT10_ DOWNB	-	-	-	-	-
		RESSEL (8-15)	-	-	-	-	-	-	-	-
		PORTSE L (0-7)	-	-	-	-	-	-	-	-
		PORTSE L (8-15)	-	-	-	-	-	-	-	-
	OCU9_FC MD0	RESSEL (0-7)	FRT8_F CMD	FRT9_F CMD	FRT10_ FCMD	-	-	-	-	-
		RESSEL (8-15)	-	-	-	-	-	-	-	-
		PORTSE L (0-7)	-	-	-	-	-	-	-	-
		PORTSE L (8-15)	-	-	-	-	-	-	-	-
	OCU9_FC MD1	RESSEL (0-7)	FRT8_F CMD	FRT9_F CMD	FRT10_ FCMD	-	-	-	-	-
		RESSEL (8-15)	-	-	-	-	-	-	-	-
		PORTSE L (0-7)	-	-	-	-	-	-	-	-
		PORTSE L (8-15)	-	-	-	-	-	-	-	-
	OCU9_MT SF0	RESSEL (0-7)	FRT8_M TSF	FRT9_M TSF	FRT10_ MTSF	-	-	-	-	-
		RESSEL (8-15)	-	-	-	-	-	-	-	-
		PORTSE L (0-7)	-	-	-	-	-	-	-	-
		PORTSE L (8-15)	-	-	-	-	-	-	-	-



Register (Offset)	Resource	RESSEL [3:0] /PORT SEL[3:0]	Source for Resource Input							
			0	1	2	3	4	5	6	7
			8	9	10	11	12	13	14	15
RIC_RE SIN259 (0x0206)	OCU9_MT SF1	RESSEL (0-7)	FRT8_M TSF	FRT9_M TSF	FRT10_ MTSF	-	-	-	-	-
		RESSEL (8-15)	-	-	-	-	-	-	-	-
		PORTSE L (0-7)	-	-	-	-	-	-	-	-
		PORTSE L (8-15)	-	-	-	-	-	-	-	-
	OCU9_T0[ 31:0]	RESSEL (0-7)	FRT8_T [31:0]	FRT9_T [31:0]	FRT10_ T[31:0]	-	-	-	-	-
		RESSEL (8-15)	-	-	-	-	-	-	-	-
		PORTSE L (0-7)	-	-	-	-	-	-	-	-
		PORTSE L (8-15)	-	-	-	-	-	-	-	-
	OCU9_T1[ 31:0]	RESSEL (0-7)	FRT8_T [31:0]	FRT9_T [31:0]	FRT10_ T[31:0]	-	-	-	-	-
		RESSEL (8-15)	-	-	-	-	-	-	-	-
		PORTSE L (0-7)	-	-	-	-	-	-	-	-
		PORTSE L (8-15)	-	-	-	-	-	-	-	-
	OCU9_ZT SF0	RESSEL (0-7)	FRT8_Z TSF	FRT9_Z TSF	FRT10_ ZTSF	-	-	-	-	-
		RESSEL (8-15)	-	-	-	-	-	-	-	-
		PORTSE L (0-7)	-	-	-	-	-	-	-	-
		PORTSE L (8-15)	-	-	-	-	-	-	-	-
	OCU9_ZT SF1	RESSEL (0-7)	FRT8_Z TSF	FRT9_Z TSF	FRT10_ ZTSF	-	-	-	-	-
		RESSEL (8-15)	-	-	-	-	-	-	-	-
		PORTSE L (0-7)	-	-	-	-	-	-	-	-
		PORTSE L (8-15)	-	-	-	-	-	-	-	-

Register (Offset)	Resource	RESSEL [3:0] /PORT SEL[3:0]	Source for Resource Input							
			0	1	2	3	4	5	6	7
			8	9	10	11	12	13	14	15
RIC_RE SIN260 (0x0208)	OCU9_M OD0	RESSEL (0-7)	set 1	set 0	-	-	-	-	-	-
		RESSEL (8-15)	-	-	-	-	-	-	-	-
		PORTSE L (0-7)	-	-	-	-	-	-	-	-
		PORTSE L (8-15)	-	-	-	-	-	-	-	-
RIC_RE SIN261 (0x020A)	OCU9_M OD1	RESSEL (0-7)	set 1	set 0	-	-	-	-	-	-
		RESSEL (8-15)	-	-	-	-	-	-	-	-
		PORTSE L (0-7)	-	-	-	-	-	-	-	-
		PORTSE L (8-15)	-	-	-	-	-	-	-	-

Register (Offset)	Resource	RESSEL [3:0] /PORT SEL[3:0]	Source for Resource Input							
			0	1	2	3	4	5	6	7
			8	9	10	11	12	13	14	15
RIC_RE SIN262 (0x020C)	OCU10_C K0	RESSEL (0-7)	FRT8	FRT9	FRT10	-	-	-	-	-
		RESSEL (8-15)	-	-	-	-	-	-	-	-
		PORTSE L (0-7)	-	-	-	-	-	-	-	-
		PORTSE L (8-15)	-	-	-	-	-	-	-	-
	OCU10_C K1	RESSEL (0-7)	FRT8	FRT9	FRT10	-	-	-	-	-
		RESSEL (8-15)	-	-	-	-	-	-	-	-
		PORTSE L (0-7)	-	-	-	-	-	-	-	-
		PORTSE L (8-15)	-	-	-	-	-	-	-	-
	OCU10_D OWNB0	RESSEL (0-7)	FRT8_D OWNB	FRT9_D OWNB	FRT10_ DOWNB	-	-	-	-	-
		RESSEL (8-15)	-	-	-	-	-	-	-	-
		PORTSE L (0-7)	-	-	-	-	-	-	-	-
		PORTSE L (8-15)	-	-	-	-	-	-	-	-
	OCU10_D OWNB1	RESSEL (0-7)	FRT8_D OWNB	FRT9_D OWNB	FRT10_ DOWNB	-	-	-	-	-
		RESSEL (8-15)	-	-	-	-	-	-	-	-
		PORTSE L (0-7)	-	-	-	-	-	-	-	-
		PORTSE L (8-15)	-	-	-	-	-	-	-	-
	OCU10_F CMD0	RESSEL (0-7)	FRT8_F CMD	FRT9_F CMD	FRT10_ FCMD	-	-	-	-	-
		RESSEL (8-15)	-	-	-	-	-	-	-	-
		PORTSE L (0-7)	-	-	-	-	-	-	-	-
		PORTSE L (8-15)	-	-	-	-	-	-	-	-

Register (Offset)	Resource	RESSEL [3:0] /PORT SEL[3:0]	Source for Resource Input							
			0	1	2	3	4	5	6	7
			8	9	10	11	12	13	14	15
RIC_RE SIN262 (0x020C)	OCU10_F CMD1	RESSEL (0-7)	FRT8_F CMD	FRT9_F CMD	FRT10_ FCMD	-	-	-	-	-
		RESSEL (8-15)	-	-	-	-	-	-	-	-
		PORTSE L (0-7)	-	-	-	-	-	-	-	-
		PORTSE L (8-15)	-	-	-	-	-	-	-	-
	OCU10_M TSF0	RESSEL (0-7)	FRT8_M TSF	FRT9_M TSF	FRT10_ MTSF	-	-	-	-	-
		RESSEL (8-15)	-	-	-	-	-	-	-	-
		PORTSE L (0-7)	-	-	-	-	-	-	-	-
		PORTSE L (8-15)	-	-	-	-	-	-	-	-
	OCU10_M TSF1	RESSEL (0-7)	FRT8_M TSF	FRT9_M TSF	FRT10_ MTSF	-	-	-	-	-
		RESSEL (8-15)	-	-	-	-	-	-	-	-
		PORTSE L (0-7)	-	-	-	-	-	-	-	-
		PORTSE L (8-15)	-	-	-	-	-	-	-	-
	OCU10_T 0[31:0]	RESSEL (0-7)	FRT8_T [31:0]	FRT9_T [31:0]	FRT10_ T[31:0]	-	-	-	-	-
		RESSEL (8-15)	-	-	-	-	-	-	-	-
		PORTSE L (0-7)	-	-	-	-	-	-	-	-
		PORTSE L (8-15)	-	-	-	-	-	-	-	-
	OCU10_T 1[31:0]	RESSEL (0-7)	FRT8_T [31:0]	FRT9_T [31:0]	FRT10_ T[31:0]	-	-	-	-	-
		RESSEL (8-15)	-	-	-	-	-	-	-	-
		PORTSE L (0-7)	-	-	-	-	-	-	-	-
		PORTSE L (8-15)	-	-	-	-	-	-	-	-

Register (Offset)	Resource	RESSEL [3:0] /PORT SEL[3:0]	Source for Resource Input							
			0	1	2	3	4	5	6	7
			8	9	10	11	12	13	14	15
RIC_RE SIN262 (0x020C)	OCU10_Z TSF0	RESSEL (0-7)	FRT8_Z TSF	FRT9_Z TSF	FRT10_ ZTSF	-	-	-	-	-
		RESSEL (8-15)	-	-	-	-	-	-	-	-
		PORTSE L (0-7)	-	-	-	-	-	-	-	-
		PORTSE L (8-15)	-	-	-	-	-	-	-	-
	OCU10_Z TSF1	RESSEL (0-7)	FRT8_Z TSF	FRT9_Z TSF	FRT10_ ZTSF	-	-	-	-	-
		RESSEL (8-15)	-	-	-	-	-	-	-	-
		PORTSE L (0-7)	-	-	-	-	-	-	-	-
		PORTSE L (8-15)	-	-	-	-	-	-	-	-
RIC_RE SIN263 (0x020E)	OCU10_M OD0	RESSEL (0-7)	set 1	set 0	-	-	-	-	-	
		RESSEL (8-15)	-	-	-	-	-	-	-	
		PORTSE L (0-7)	-	-	-	-	-	-	-	
		PORTSE L (8-15)	-	-	-	-	-	-	-	
RIC_RE SIN264 (0x0210)	OCU10_M OD1	RESSEL (0-7)	set 1	set 0	-	-	-	-	-	
		RESSEL (8-15)	-	-	-	-	-	-	-	
		PORTSE L (0-7)	-	-	-	-	-	-	-	
		PORTSE L (8-15)	-	-	-	-	-	-	-	
RIC_RE SIN280 (0x0230)	ICU0_IN0	RESSEL (0-7)	PORT_ PIN	MFS0_L SYN	-	-	-	-	-	
		RESSEL (8-15)	-	-	-	-	-	-	-	
		PORTSE L (0-7)	P1_03	P3_08	-	-	-	-	-	
		PORTSE L (8-15)	-	-	-	-	-	-	-	

Register (Offset)	Resource	RESSEL [3:0] /PORT SEL[3:0]	Source for Resource Input							
			0	1	2	3	4	5	6	7
			8	9	10	11	12	13	14	15
RIC_RE SIN281 (0x0232)	ICU0_IN1	RESSEL (0-7)	PORT_ PIN	MFS1_L SYN	-	-	-	-	-	-
		RESSEL (8-15)	-	-	-	-	-	-	-	-
		PORTSE L (0-7)	P1_04	P3_09	-	-	-	-	-	-
		PORTSE L (8-15)	-	-	-	-	-	-	-	-
RIC_RE SIN282 (0x0234)	ICU0_T0[ 31:0]	RESSEL (0-7)	FRT0_T [31:0]	FRT1_T [31:0]	FRT2_T [31:0]	FRT3_T [31:0]	FRT4_T [31:0]	-	-	-
		RESSEL (8-15)	-	-	-	-	-	-	-	-
		PORTSE L (0-7)	-	-	-	-	-	-	-	-
		PORTSE L (8-15)	-	-	-	-	-	-	-	-
	ICU0_T1[ 31:0]	RESSEL (0-7)	FRT0_T [31:0]	FRT1_T [31:0]	FRT2_T [31:0]	FRT3_T [31:0]	FRT4_T [31:0]	-	-	-
		RESSEL (8-15)	-	-	-	-	-	-	-	-
		PORTSE L (0-7)	-	-	-	-	-	-	-	-
		PORTSE L (8-15)	-	-	-	-	-	-	-	-
RIC_RE SIN283 (0x0236)	ICU1_IN0	RESSEL (0-7)	PORT_ PIN	MFS2_L SYN	-	-	-	-	-	
		RESSEL (8-15)	-	-	-	-	-	-	-	
		PORTSE L (0-7)	P1_05	P3_10	-	-	-	-	-	
		PORTSE L (8-15)	-	-	-	-	-	-	-	
RIC_RE SIN284 (0x0238)	ICU1_IN1	RESSEL (0-7)	PORT_ PIN	MFS3_L SYN	-	-	-	-	-	
		RESSEL (8-15)	-	-	-	-	-	-	-	
		PORTSE L (0-7)	P1_06	P3_11	-	-	-	-	-	
		PORTSE L (8-15)	-	-	-	-	-	-	-	

Register (Offset)	Resource	RESSEL [3:0] /PORT SEL[3:0]	Source for Resource Input							
			0	1	2	3	4	5	6	7
			8	9	10	11	12	13	14	15
RIC_RE SIN285 (0x023A)	ICU1_T0[31:0]	RESSEL (0-7)	FRT0_T [31:0]	FRT1_T [31:0]	FRT2_T [31:0]	FRT3_T [31:0]	FRT4_T [31:0]	-	-	-
		RESSEL (8-15)	-	-	-	-	-	-	-	-
		PORTSEL (0-7)	-	-	-	-	-	-	-	-
		PORTSEL (8-15)	-	-	-	-	-	-	-	-
	ICU1_T1[31:0]	RESSEL (0-7)	FRT0_T [31:0]	FRT1_T [31:0]	FRT2_T [31:0]	FRT3_T [31:0]	FRT4_T [31:0]	-	-	-
		RESSEL (8-15)	-	-	-	-	-	-	-	-
		PORTSEL (0-7)	-	-	-	-	-	-	-	-
		PORTSEL (8-15)	-	-	-	-	-	-	-	-
RIC_RE SIN286 (0x023C)	ICU2_IN0	RESSEL (0-7)	PORT_PIN	MFS4_L SYN	-	-	-	-	-	
		RESSEL (8-15)	-	-	-	-	-	-	-	
		PORTSEL (0-7)	P1_07	P3_12	-	-	-	-	-	
		PORTSEL (8-15)	-	-	-	-	-	-	-	
RIC_RE SIN287 (0x023E)	ICU2_IN1	RESSEL (0-7)	PORT_PIN	-	-	-	-	-	-	
		RESSEL (8-15)	-	-	-	-	-	-	-	
		PORTSEL (0-7)	P1_08	P3_13	-	-	-	-	-	
		PORTSEL (8-15)	-	-	-	-	-	-	-	

Register (Offset)	Resource	RESSEL [3:0] /PORT SEL[3:0]	Source for Resource Input							
			0	1	2	3	4	5	6	7
			8	9	10	11	12	13	14	15
RIC_RE SIN288 (0x0240)	ICU2_T0[ 31:0]	RESSEL (0-7)	FRT0_T [31:0]	FRT1_T [31:0]	FRT2_T [31:0]	FRT3_T [31:0]	FRT4_T [31:0]	-	-	-
		RESSEL (8-15)	-	-	-	-	-	-	-	-
		PORTSE L (0-7)	-	-	-	-	-	-	-	-
		PORTSE L (8-15)	-	-	-	-	-	-	-	-
	ICU2_T1[ 31:0]	RESSEL (0-7)	FRT0_T [31:0]	FRT1_T [31:0]	FRT2_T [31:0]	FRT3_T [31:0]	FRT4_T [31:0]	-	-	-
		RESSEL (8-15)	-	-	-	-	-	-	-	-
		PORTSE L (0-7)	-	-	-	-	-	-	-	-
		PORTSE L (8-15)	-	-	-	-	-	-	-	-
RIC_RE SIN304 (0x0260)	ICU8_IN0	RESSEL (0-7)	PORT_ PIN	MFS8_L SYN	-	-	-	-	-	
		RESSEL (8-15)	-	-	-	-	-	-	-	
		PORTSE L (0-7)	P1_09	P3_14	-	-	-	-	-	
		PORTSE L (8-15)	-	-	-	-	-	-	-	
RIC_RE SIN305 (0x0262)	ICU8_IN1	RESSEL (0-7)	PORT_ PIN	MFS9_L SYN	-	-	-	-	-	
		RESSEL (8-15)	-	-	-	-	-	-	-	
		PORTSE L (0-7)	P1_10	P3_15	-	-	-	-	-	
		PORTSE L (8-15)	-	-	-	-	-	-	-	



Register (Offset)	Resource	RESSEL [3:0] /PORT SEL[3:0]	Source for Resource Input							
			0	1	2	3	4	5	6	7
			8	9	10	11	12	13	14	15
RIC_RE SIN306 (0x0264)	ICU8_T0[ 31:0]	RESSEL (0-7)	FRT8_T [31:0]	FRT9_T [31:0]	FRT10_ T[31:0]	-	-	-	-	-
		RESSEL (8-15)	-	-	-	-	-	-	-	-
		PORTSE L (0-7)	-	-	-	-	-	-	-	-
		PORTSE L (8-15)	-	-	-	-	-	-	-	-
	ICU8_T1[ 31:0]	RESSEL (0-7)	FRT8_T [31:0]	FRT9_T [31:0]	FRT10_ T[31:0]	-	-	-	-	-
		RESSEL (8-15)	-	-	-	-	-	-	-	-
		PORTSE L (0-7)	-	-	-	-	-	-	-	-
		PORTSE L (8-15)	-	-	-	-	-	-	-	-
RIC_RE SIN307 (0x0266)	ICU9_IN0	RESSEL (0-7)	PORT_ PIN	MFS10_ LSYN	-	-	-	-	-	
		RESSEL (8-15)	-	-	-	-	-	-	-	
		PORTSE L (0-7)	P1_11	P3_16	-	-	-	-	-	
		PORTSE L (8-15)	-	-	-	-	-	-	-	
RIC_RE SIN308 (0x0268)	ICU9_IN1	RESSEL (0-7)	PORT_ PIN	MFS11_ LSYN	-	-	-	-	-	
		RESSEL (8-15)	-	-	-	-	-	-	-	
		PORTSE L (0-7)	P1_12	P3_17	-	-	-	-	-	
		PORTSE L (8-15)	-	-	-	-	-	-	-	

Register (Offset)	Resource	RESSEL [3:0] /PORT SEL[3:0]	Source for Resource Input							
			0	1	2	3	4	5	6	7
			8	9	10	11	12	13	14	15
RIC_RE SIN309 (0x026A)	ICU9_T0[31:0]	RESSEL (0-7)	FRT8_T [31:0]	FRT9_T [31:0]	FRT10_T [31:0]	-	-	-	-	-
		RESSEL (8-15)	-	-	-	-	-	-	-	-
		PORTSEL (0-7)	-	-	-	-	-	-	-	-
		PORTSEL (8-15)	-	-	-	-	-	-	-	-
	ICU9_T1[31:0]	RESSEL (0-7)	FRT8_T [31:0]	FRT9_T [31:0]	FRT10_T [31:0]	-	-	-	-	-
		RESSEL (8-15)	-	-	-	-	-	-	-	-
		PORTSEL (0-7)	-	-	-	-	-	-	-	-
		PORTSEL (8-15)	-	-	-	-	-	-	-	-
RIC_RE SIN310 (0x026C)	ICU10_IN 0	RESSEL (0-7)	PORT_PIN	MFS12_LSYN	-	-	-	-	-	
		RESSEL (8-15)	-	-	-	-	-	-	-	
		PORTSEL (0-7)	P1_14	P3_18	-	-	-	-	-	
		PORTSEL (8-15)	-	-	-	-	-	-	-	
RIC_RE SIN311 (0x026E)	ICU10_IN 1	RESSEL (0-7)	PORT_PIN	-	-	-	-	-	-	
		RESSEL (8-15)	-	-	-	-	-	-	-	
		PORTSEL (0-7)	P1_15	P3_19	-	-	-	-	-	
		PORTSEL (8-15)	-	-	-	-	-	-	-	

Register (Offset)	Resource	RESSEL [3:0] /PORT SEL[3:0]	Source for Resource Input							
			0	1	2	3	4	5	6	7
			8	9	10	11	12	13	14	15
RIC_RE SIN312 (0x0270)	ICU10_T0 [31:0]	RESSEL (0-7)	FRT8_T [31:0]	FRT9_T [31:0]	FRT10_T [31:0]	-	-	-	-	-
		RESSEL (8-15)	-	-	-	-	-	-	-	-
		PORTSE L (0-7)	-	-	-	-	-	-	-	-
		PORTSE L (8-15)	-	-	-	-	-	-	-	-
	ICU10_T1 [31:0]	RESSEL (0-7)	FRT8_T [31:0]	FRT9_T [31:0]	FRT10_T [31:0]	-	-	-	-	-
		RESSEL (8-15)	-	-	-	-	-	-	-	-
		PORTSE L (0-7)	-	-	-	-	-	-	-	-
		PORTSE L (8-15)	-	-	-	-	-	-	-	-
RIC_RE SIN352 (0x02C0)	AIN8	RESSEL (0-7)	PORT_ PIN	TOT0	-	-	-	-	-	
		RESSEL (8-15)	-	-	-	-	-	-	-	
		PORTSE L (0-7)	-	-	-	-	-	-	-	
		PORTSE L (8-15)	-	-	-	-	-	-	-	
RIC_RE SIN353 (0x02C2)	BIN8	RESSEL (0-7)	PORT_ PIN	TOT1	-	-	-	-	-	
		RESSEL (8-15)	-	-	-	-	-	-	-	
		PORTSE L (0-7)	-	-	-	-	-	-	-	
		PORTSE L (8-15)	-	-	-	-	-	-	-	
RIC_RE SIN354 (0x02C4)	ZIN8	RESSEL (0-7)	PORT_ PIN	TOT16	PPG6_T OUT0	PPG6_T OUT2	PPG7_T OUT0	-	-	
		RESSEL (8-15)	-	-	-	-	-	-	-	
		PORTSE L (0-7)	-	-	-	-	-	-	-	
		PORTSE L (8-15)	-	-	-	-	-	-	-	

Register (Offset)	Resource	RESSEL [3:0] /PORT SEL[3:0]	Source for Resource Input							
			0	1	2	3	4	5	6	7
			8	9	10	11	12	13	14	15
RIC_RE SIN355 (0x02C6)	AIN9	RESSEL (0-7)	PORT_PIN	TOT16	-	-	-	-	-	-
		RESSEL (8-15)	-	-	-	-	-	-	-	-
		PORTSEL (0-7)	-	-	-	-	-	-	-	-
		PORTSEL (8-15)	-	-	-	-	-	-	-	-
RIC_RE SIN356 (0x02C8)	BIN9	RESSEL (0-7)	PORT_PIN	TOT17	-	-	-	-	-	-
		RESSEL (8-15)	-	-	-	-	-	-	-	-
		PORTSEL (0-7)	-	-	-	-	-	-	-	-
		PORTSEL (8-15)	-	-	-	-	-	-	-	-
RIC_RE SIN357 (0x02CA)	ZIN9	RESSEL (0-7)	PORT_PIN	TOT0	PPG6_TOUT0	PPG6_TOUT2	PPG7_TOUT0	-	-	-
		RESSEL (8-15)	-	-	-	-	-	-	-	-
		PORTSEL (0-7)	-	-	-	-	-	-	-	-
		PORTSEL (8-15)	-	-	-	-	-	-	-	-
RIC_RE SIN376 (0x02F0)	PPG0_TIN1	RESSEL (0-7)	PORT_PIN	TOT0	RLT0_UFSET	TOT0	RLT0_UFSET	FRT0_MTSF	OCU0_OTD0	-
		RESSEL (8-15)	-	-	-	-	-	-	-	-
		PORTSEL (0-7)	P1_16	P3_04	-	-	-	-	-	-
		PORTSEL (8-15)	-	-	-	-	-	-	-	-
RIC_RE SIN377 (0x02F2)	PPG0_TIN2	RESSEL (0-7)	set 0	-	-	-	-	-	-	-
		RESSEL (8-15)	-	-	-	-	-	-	-	-
		PORTSEL (0-7)	-	-	-	-	-	-	-	-
		PORTSEL (8-15)	-	-	-	-	-	-	-	-

Register (Offset)	Resource	RESSEL [3:0] /PORT SEL[3:0]	Source for Resource Input							
			0	1	2	3	4	5	6	7
			8	9	10	11	12	13	14	15
RIC_RE SIN378 (0x02F4)	PPG0_TI N3	RESSEL (0-7)	set 0	-	-	-	-	-	-	-
		RESSEL (8-15)	-	-	-	-	-	-	-	-
		PORTSE L (0-7)	-	-	-	-	-	-	-	-
		PORTSE L (8-15)	-	-	-	-	-	-	-	-
RIC_RE SIN379 (0x02F6)	PPG1_TI N1	RESSEL (0-7)	PORT_ PIN	TOT0	RLT0_U FSET	TOT0	RLT0_U FSET	FRT0_M TSF	OCU0_ OTD0	-
		RESSEL (8-15)	-	-	-	-	-	-	-	-
		PORTSE L (0-7)	P1_16	P3_04	-	-	-	-	-	-
		PORTSE L (8-15)	-	-	-	-	-	-	-	-
RIC_RE SIN380 (0x02F8)	PPG1_TI N2	RESSEL (0-7)	set 0	-	-	-	-	-	-	-
		RESSEL (8-15)	-	-	-	-	-	-	-	-
		PORTSE L (0-7)	-	-	-	-	-	-	-	-
		PORTSE L (8-15)	-	-	-	-	-	-	-	-
RIC_RE SIN381 (0x02FA)	PPG1_TI N3	RESSEL (0-7)	set 0	-	-	-	-	-	-	-
		RESSEL (8-15)	-	-	-	-	-	-	-	-
		PORTSE L (0-7)	-	-	-	-	-	-	-	-
		PORTSE L (8-15)	-	-	-	-	-	-	-	-
RIC_RE SIN382 (0x02FC)	PPG2_TI N1	RESSEL (0-7)	PORT_ PIN	TOT0	RLT0_U FSET	TOT0	RLT0_U FSET	FRT0_M TSF	OCU0_ OTD0	-
		RESSEL (8-15)	-	-	-	-	-	-	-	-
		PORTSE L (0-7)	P1_16	P3_04	-	-	-	-	-	-
		PORTSE L (8-15)	-	-	-	-	-	-	-	-

Register (Offset)	Resource	RESSEL [3:0] /PORT SEL[3:0]	Source for Resource Input								
			0	1	2	3	4	5	6	7	
			8	9	10	11	12	13	14	15	
RIC_RE SIN383 (0x02FE)	PPG2_TI N2	RESSEL (0-7)	set 0	-	-	-	-	-	-	-	-
		RESSEL (8-15)	-	-	-	-	-	-	-	-	-
		PORTSE L (0-7)	-	-	-	-	-	-	-	-	-
		PORTSE L (8-15)	-	-	-	-	-	-	-	-	-
RIC_RE SIN384 (0x0300)	PPG2_TI N3	RESSEL (0-7)	set 0	-	-	-	-	-	-	-	-
		RESSEL (8-15)	-	-	-	-	-	-	-	-	-
		PORTSE L (0-7)	-	-	-	-	-	-	-	-	-
		PORTSE L (8-15)	-	-	-	-	-	-	-	-	-
RIC_RE SIN385 (0x0302)	PPG3_TI N1	RESSEL (0-7)	PORT_ PIN	TOT0	RLT0_U FSET	TOT1	RLT1_U FSET	FRT0_M TSF	OCU0_ OTD0	-	-
		RESSEL (8-15)	-	-	-	-	-	-	-	-	-
		PORTSE L (0-7)	P1_16	P3_04	-	-	-	-	-	-	-
		PORTSE L (8-15)	-	-	-	-	-	-	-	-	-
RIC_RE SIN386 (0x0304)	PPG3_TI N2	RESSEL (0-7)	set 0	-	-	-	-	-	-	-	-
		RESSEL (8-15)	-	-	-	-	-	-	-	-	-
		PORTSE L (0-7)	-	-	-	-	-	-	-	-	-
		PORTSE L (8-15)	-	-	-	-	-	-	-	-	-
RIC_RE SIN387 (0x0306)	PPG3_TI N3	RESSEL (0-7)	set 0	-	-	-	-	-	-	-	-
		RESSEL (8-15)	-	-	-	-	-	-	-	-	-
		PORTSE L (0-7)	-	-	-	-	-	-	-	-	-
		PORTSE L (8-15)	-	-	-	-	-	-	-	-	-

Register (Offset)	Resource	RESSEL [3:0] /PORT SEL[3:0]	Source for Resource Input							
			0	1	2	3	4	5	6	7
			8	9	10	11	12	13	14	15
RIC_RE SIN388 (0x0308)	PPG4_TI N1	RESSEL (0-7)	PORT_ PIN	TOT0	RLT0_U FSET	TOT1	RLT1_U FSET	FRT0_M TSF	OCU0_ OTD0	-
		RESSEL (8-15)	-	-	-	-	-	-	-	-
		PORTSE L (0-7)	P1_16	P3_04	-	-	-	-	-	-
		PORTSE L (8-15)	-	-	-	-	-	-	-	-
RIC_RE SIN389 (0x030A)	PPG4_TI N2	RESSEL (0-7)	set 0	-	-	-	-	-	-	-
		RESSEL (8-15)	-	-	-	-	-	-	-	-
		PORTSE L (0-7)	-	-	-	-	-	-	-	-
		PORTSE L (8-15)	-	-	-	-	-	-	-	-
RIC_RE SIN390 (0x030C)	PPG4_TI N3	RESSEL (0-7)	set 0	-	-	-	-	-	-	-
		RESSEL (8-15)	-	-	-	-	-	-	-	-
		PORTSE L (0-7)	-	-	-	-	-	-	-	-
		PORTSE L (8-15)	-	-	-	-	-	-	-	-
RIC_RE SIN391 (0x030E)	PPG5_TI N1	RESSEL (0-7)	PORT_ PIN	TOT0	RLT0_U FSET	TOT1	RLT1_U FSET	FRT0_M TSF	OCU0_ OTD0	-
		RESSEL (8-15)	-	-	-	-	-	-	-	-
		PORTSE L (0-7)	P1_16	P3_04	-	-	-	-	-	-
		PORTSE L (8-15)	-	-	-	-	-	-	-	-
RIC_RE SIN392 (0x0310)	PPG5_TI N2	RESSEL (0-7)	set 0	-	-	-	-	-	-	-
		RESSEL (8-15)	-	-	-	-	-	-	-	-
		PORTSE L (0-7)	-	-	-	-	-	-	-	-
		PORTSE L (8-15)	-	-	-	-	-	-	-	-

Register (Offset)	Resource	RESSEL [3:0] /PORT SEL[3:0]	Source for Resource Input							
			0	1	2	3	4	5	6	7
			8	9	10	11	12	13	14	15
RIC_RE SIN393 (0x0312)	PPG5_TI N3	RESSEL (0-7)	set 0	-	-	-	-	-	-	-
		RESSEL (8-15)	-	-	-	-	-	-	-	-
		PORTSE L (0-7)	-	-	-	-	-	-	-	-
		PORTSE L (8-15)	-	-	-	-	-	-	-	-
RIC_RE SIN394 (0x0314)	PPG6_TI N1	RESSEL (0-7)	PORT_ PIN	TOT0	RLT0_U FSET	TOT16	RLT16_ UFSET	FRT8_M TSF	OCU8_ OTD0	-
		RESSEL (8-15)	-	-	-	-	-	-	-	-
		PORTSE L (0-7)	P1_29	P3_20	-	-	-	-	-	-
		PORTSE L (8-15)	-	-	-	-	-	-	-	-
RIC_RE SIN395 (0x0316)	PPG6_TI N2	RESSEL (0-7)	set 0	-	-	-	-	-	-	-
		RESSEL (8-15)	-	-	-	-	-	-	-	-
		PORTSE L (0-7)	-	-	-	-	-	-	-	-
		PORTSE L (8-15)	-	-	-	-	-	-	-	-
RIC_RE SIN396 (0x0318)	PPG6_TI N3	RESSEL (0-7)	set 0	-	-	-	-	-	-	-
		RESSEL (8-15)	-	-	-	-	-	-	-	-
		PORTSE L (0-7)	-	-	-	-	-	-	-	-
		PORTSE L (8-15)	-	-	-	-	-	-	-	-
RIC_RE SIN397 (0x031A)	PPG7_TI N1	RESSEL (0-7)	PORT_ PIN	TOT0	RLT0_U FSET	TOT16	RLT16_ UFSET	FRT8_M TSF	OCU8_ OTD0	-
		RESSEL (8-15)	-	-	-	-	-	-	-	-
		PORTSE L (0-7)	P1_29	P3_20	-	-	-	-	-	-
		PORTSE L (8-15)	-	-	-	-	-	-	-	-



Register (Offset)	Resource	RESSEL [3:0] /PORT SEL[3:0]	Source for Resource Input								
			0	1	2	3	4	5	6	7	
			8	9	10	11	12	13	14	15	
RIC_RE SIN398 (0x031C)	PPG7_TI N2	RESSEL (0-7)	set 0	-	-	-	-	-	-	-	-
		RESSEL (8-15)	-	-	-	-	-	-	-	-	-
		PORTSE L (0-7)	-	-	-	-	-	-	-	-	-
		PORTSE L (8-15)	-	-	-	-	-	-	-	-	-
RIC_RE SIN399 (0x031E)	PPG7_TI N3	RESSEL (0-7)	set 0	-	-	-	-	-	-	-	-
		RESSEL (8-15)	-	-	-	-	-	-	-	-	-
		PORTSE L (0-7)	-	-	-	-	-	-	-	-	-
		PORTSE L (8-15)	-	-	-	-	-	-	-	-	-
RIC_RE SIN400 (0x0320)	PPG8_TI N1	RESSEL (0-7)	PORT_ PIN	TOT0	RLT0_U FSET	TOT16	RLT16_ UFSET	FRT8_M TSF	OCU8_ OTD0	-	-
		RESSEL (8-15)	-	-	-	-	-	-	-	-	-
		PORTSE L (0-7)	P1_29	P3_20	-	-	-	-	-	-	-
		PORTSE L (8-15)	-	-	-	-	-	-	-	-	-
RIC_RE SIN401 (0x0322)	PPG8_TI N2	RESSEL (0-7)	set 0	-	-	-	-	-	-	-	-
		RESSEL (8-15)	-	-	-	-	-	-	-	-	-
		PORTSE L (0-7)	-	-	-	-	-	-	-	-	-
		PORTSE L (8-15)	-	-	-	-	-	-	-	-	-
RIC_RE SIN402 (0x0324)	PPG8_TI N3	RESSEL (0-7)	set 0	-	-	-	-	-	-	-	-
		RESSEL (8-15)	-	-	-	-	-	-	-	-	-
		PORTSE L (0-7)	-	-	-	-	-	-	-	-	-
		PORTSE L (8-15)	-	-	-	-	-	-	-	-	-

Register (Offset)	Resource	RESSEL [3:0] /PORT SEL[3:0]	Source for Resource Input							
			0	1	2	3	4	5	6	7
			8	9	10	11	12	13	14	15
RIC_RE SIN403 (0x0326)	PPG9_TI N1	RESSEL (0-7)	PORT_ PIN	TOT0	RLT0_U FSET	TOT17	RLT17_ UFSET	FRT8_M TSF	OCU8_ OTD0	-
		RESSEL (8-15)	-	-	-	-	-	-	-	-
		PORTSE L (0-7)	P1_29	P3_20	-	-	-	-	-	-
		PORTSE L (8-15)	-	-	-	-	-	-	-	-
RIC_RE SIN404 (0x0328)	PPG9_TI N2	RESSEL (0-7)	set 0	-	-	-	-	-	-	-
		RESSEL (8-15)	-	-	-	-	-	-	-	-
		PORTSE L (0-7)	-	-	-	-	-	-	-	-
		PORTSE L (8-15)	-	-	-	-	-	-	-	-
RIC_RE SIN405 (0x032A)	PPG9_TI N3	RESSEL (0-7)	set 0	-	-	-	-	-	-	-
		RESSEL (8-15)	-	-	-	-	-	-	-	-
		PORTSE L (0-7)	-	-	-	-	-	-	-	-
		PORTSE L (8-15)	-	-	-	-	-	-	-	-
RIC_RE SIN406 (0x032C)	PPG10_TI N1	RESSEL (0-7)	PORT_ PIN	TOT0	RLT0_U FSET	TOT17	RLT17_ UFSET	FRT8_M TSF	OCU8_ OTD0	-
		RESSEL (8-15)	-	-	-	-	-	-	-	-
		PORTSE L (0-7)	P1_29	P3_20	-	-	-	-	-	-
		PORTSE L (8-15)	-	-	-	-	-	-	-	-
RIC_RE SIN407 (0x032E)	PPG10_TI N2	RESSEL (0-7)	set 0	-	-	-	-	-	-	-
		RESSEL (8-15)	-	-	-	-	-	-	-	-
		PORTSE L (0-7)	-	-	-	-	-	-	-	-
		PORTSE L (8-15)	-	-	-	-	-	-	-	-

Register (Offset)	Resource	RESSEL [3:0] /PORT SEL[3:0]	Source for Resource Input							
			0	1	2	3	4	5	6	7
			8	9	10	11	12	13	14	15
RIC_RE SIN408 (0x0330)	PPG10_TI N3	RESSEL (0-7)	set 0	-	-	-	-	-	-	-
		RESSEL (8-15)	-	-	-	-	-	-	-	-
		PORTSE L (0-7)	-	-	-	-	-	-	-	-
		PORTSE L (8-15)	-	-	-	-	-	-	-	-
RIC_RE SIN409 (0x0332)	PPG11_TI N1	RESSEL (0-7)	PORT_ PIN	TOT0	RLT0_U FSET	TOT17	RLT17_ UFSET	FRT8_M TSF	OCU8_ OTD0	-
		RESSEL (8-15)	-	-	-	-	-	-	-	-
		PORTSE L (0-7)	P1_29	P3_20	-	-	-	-	-	-
		PORTSE L (8-15)	-	-	-	-	-	-	-	-
RIC_RE SIN410 (0x0334)	PPG11_TI N2	RESSEL (0-7)	set 0	-	-	-	-	-	-	-
		RESSEL (8-15)	-	-	-	-	-	-	-	-
		PORTSE L (0-7)	-	-	-	-	-	-	-	-
		PORTSE L (8-15)	-	-	-	-	-	-	-	-
RIC_RE SIN411 (0x0336)	PPG11_TI N3	RESSEL (0-7)	set 0	-	-	-	-	-	-	-
		RESSEL (8-15)	-	-	-	-	-	-	-	-
		PORTSE L (0-7)	-	-	-	-	-	-	-	-
		PORTSE L (8-15)	-	-	-	-	-	-	-	-
RIC_RE SIN430 (0x035C)	PPG12_TI N1	RESSEL (0-7)	PORT_ PIN	TOT0	RLT0_U FSET	-	-	-	-	-
		RESSEL (8-15)	-	-	-	-	-	-	-	-
		PORTSE L (0-7)	P2_06	P3_31	-	-	-	-	-	-
		PORTSE L (8-15)	-	-	-	-	-	-	-	-

Register (Offset)	Resource	RESSEL [3:0] /PORT SEL[3:0]	Source for Resource Input										
			0	1	2	3	4	5	6	7			
			8	9	10	11	12	13	14	15			
RIC_RE SIN431 (0x035E)	PPG12_TI N2	RESSEL (0-7)	set 0	-	-	-	-	-	-	-	-	-	-
		RESSEL (8-15)	-	-	-	-	-	-	-	-	-	-	-
		PORTSE L (0-7)	-	-	-	-	-	-	-	-	-	-	-
		PORTSE L (8-15)	-	-	-	-	-	-	-	-	-	-	-
RIC_RE SIN432 (0x0360)	PPG12_TI N3	RESSEL (0-7)	set 0	-	-	-	-	-	-	-	-	-	-
		RESSEL (8-15)	-	-	-	-	-	-	-	-	-	-	-
		PORTSE L (0-7)	-	-	-	-	-	-	-	-	-	-	-
		PORTSE L (8-15)	-	-	-	-	-	-	-	-	-	-	-
RIC_RE SIN433 (0x0362)	PPG13_TI N1	RESSEL (0-7)	PORT_ PIN	TOT0	RLT0_U FSET	-	-	-	-	-	-	-	-
		RESSEL (8-15)	-	-	-	-	-	-	-	-	-	-	-
		PORTSE L (0-7)	P2_06	P3_31	-	-	-	-	-	-	-	-	-
		PORTSE L (8-15)	-	-	-	-	-	-	-	-	-	-	-
RIC_RE SIN434 (0x0364)	PPG13_TI N2	RESSEL (0-7)	set 0	-	-	-	-	-	-	-	-	-	-
		RESSEL (8-15)	-	-	-	-	-	-	-	-	-	-	-
		PORTSE L (0-7)	-	-	-	-	-	-	-	-	-	-	-
		PORTSE L (8-15)	-	-	-	-	-	-	-	-	-	-	-
RIC_RE SIN435 (0x0366)	PPG13_TI N3	RESSEL (0-7)	set 0	-	-	-	-	-	-	-	-	-	-
		RESSEL (8-15)	-	-	-	-	-	-	-	-	-	-	-
		PORTSE L (0-7)	-	-	-	-	-	-	-	-	-	-	-
		PORTSE L (8-15)	-	-	-	-	-	-	-	-	-	-	-

Register (Offset)	Resource	RESSEL [3:0] /PORT SEL[3:0]	Source for Resource Input							
			0	1	2	3	4	5	6	7
			8	9	10	11	12	13	14	15
RIC_RE SIN436 (0x0368)	PPG14_TI N1	RESSEL (0-7)	PORT_ PIN	TOT0	RLT0_U FSET	-	-	-	-	-
		RESSEL (8-15)	-	-	-	-	-	-	-	-
		PORTSE L (0-7)	P2_06	P3_31	-	-	-	-	-	-
		PORTSE L (8-15)	-	-	-	-	-	-	-	-
RIC_RE SIN437 (0x036A)	PPG14_TI N2	RESSEL (0-7)	set 0	-	-	-	-	-	-	-
		RESSEL (8-15)	-	-	-	-	-	-	-	-
		PORTSE L (0-7)	-	-	-	-	-	-	-	-
		PORTSE L (8-15)	-	-	-	-	-	-	-	-
RIC_RE SIN438 (0x036C)	PPG14_TI N3	RESSEL (0-7)	set 0	-	-	-	-	-	-	-
		RESSEL (8-15)	-	-	-	-	-	-	-	-
		PORTSE L (0-7)	-	-	-	-	-	-	-	-
		PORTSE L (8-15)	-	-	-	-	-	-	-	-
RIC_RE SIN439 (0x036E)	PPG15_TI N1	RESSEL (0-7)	PORT_ PIN	TOT0	RLT0_U FSET	-	-	-	-	-
		RESSEL (8-15)	-	-	-	-	-	-	-	-
		PORTSE L (0-7)	P2_06	P3_31	-	-	-	-	-	-
		PORTSE L (8-15)	-	-	-	-	-	-	-	-
RIC_RE SIN440 (0x0370)	PPG15_TI N2	RESSEL (0-7)	set 0	-	-	-	-	-	-	-
		RESSEL (8-15)	-	-	-	-	-	-	-	-
		PORTSE L (0-7)	-	-	-	-	-	-	-	-
		PORTSE L (8-15)	-	-	-	-	-	-	-	-

Register (Offset)	Resource	RESSEL [3:0] /PORT SEL[3:0]	Source for Resource Input							
			0	1	2	3	4	5	6	7
			8	9	10	11	12	13	14	15
RIC_RE SIN441 (0x0372)	PPG15_TI N3	RESSEL (0-7)	set 0	-	-	-	-	-	-	-
		RESSEL (8-15)	-	-	-	-	-	-	-	-
		PORTSE L (0-7)	-	-	-	-	-	-	-	-
		PORTSE L (8-15)	-	-	-	-	-	-	-	-
RIC_RE SIN490 (0x03D4)	ADC12B0 _HWTRG 0	RESSEL (0-7)	PORT_ PIN	RLT0_U FSET	RLT1_U FSET	OCU0_ OTD0	OCU1_ OTD0	PPG0_T OUT0	PPG1_T OUT2	PPG3_T OUT2
		RESSEL (8-15)	-	-	-	-	-	-	-	-
		PORTSE L (0-7)	-	-	-	-	-	-	-	-
		PORTSE L (8-15)	-	-	-	-	-	-	-	-
RIC_RE SIN491 (0x03D6)	ADC12B0 _HWTRG 1	RESSEL (0-7)	PORT_ PIN	RLT1_U FSET	RLT16_ UFSET	OCU1_ OTD0	OCU2_ OTD0	PPG0_T OUT2	PPG2_T OUT0	PPG4_T OUT0
		RESSEL (8-15)	-	-	-	-	-	-	-	-
		PORTSE L (0-7)	-	-	-	-	-	-	-	-
		PORTSE L (8-15)	-	-	-	-	-	-	-	-
RIC_RE SIN492 (0x03D8)	ADC12B0 _HWTRG 2	RESSEL (0-7)	PORT_ PIN	RLT16_ UFSET	RLT17_ UFSET	OCU2_ OTD0	OCU8_ OTD0	PPG1_T OUT0	PPG2_T OUT2	PPG4_T OUT2
		RESSEL (8-15)	-	-	-	-	-	-	-	-
		PORTSE L (0-7)	-	-	-	-	-	-	-	-
		PORTSE L (8-15)	-	-	-	-	-	-	-	-
RIC_RE SIN493 (0x03DA)	ADC12B0 _HWTRG 3	RESSEL (0-7)	PORT_ PIN	RLT17_ UFSET	RLT0_U FSET	OCU8_ OTD0	OCU9_ OTD0	PPG1_T OUT2	PPG3_T OUT0	PPG5_T OUT0
		RESSEL (8-15)	-	-	-	-	-	-	-	-
		PORTSE L (0-7)	-	-	-	-	-	-	-	-
		PORTSE L (8-15)	-	-	-	-	-	-	-	-

Register (Offset)	Resource	RESSEL [3:0] /PORT SEL[3:0]	Source for Resource Input							
			0	1	2	3	4	5	6	7
			8	9	10	11	12	13	14	15
RIC_RE SIN494 (0x03DC)	ADC12B0 _HWTRG 4	RESSEL (0-7)	PORT_ PIN	RLT0_U FSET	RLT16_ UFSET	OCU9_ OTD0	OCU10_ OTD0	PPG2_T OUT0	PPG3_T OUT2	PPG5_T OUT2
		RESSEL (8-15)	-	-	-	-	-	-	-	-
		PORTSE L (0-7)	-	-	-	-	-	-	-	-
		PORTSE L (8-15)	-	-	-	-	-	-	-	-
RIC_RE SIN495 (0x03DE)	ADC12B0 _HWTRG 5	RESSEL (0-7)	PORT_ PIN	RLT1_U FSET	RLT17_ UFSET	OCU10_ OTD0	OCU0_ OTD0	PPG2_T OUT2	PPG4_T OUT0	PPG6_T OUT0
		RESSEL (8-15)	-	-	-	-	-	-	-	-
		PORTSE L (0-7)	-	-	-	-	-	-	-	-
		PORTSE L (8-15)	-	-	-	-	-	-	-	-
RIC_RE SIN496 (0x03E0)	ADC12B0 _HWTRG 6	RESSEL (0-7)	PORT_ PIN	RLT16_ UFSET	RLT0_U FSET	OCU0_ OTD0	OCU2_ OTD0	PPG3_T OUT0	PPG4_T OUT2	PPG6_T OUT2
		RESSEL (8-15)	-	-	-	-	-	-	-	-
		PORTSE L (0-7)	-	-	-	-	-	-	-	-
		PORTSE L (8-15)	-	-	-	-	-	-	-	-
RIC_RE SIN497 (0x03E2)	ADC12B0 _HWTRG 7	RESSEL (0-7)	PORT_ PIN	RLT17_ UFSET	RLT1_U FSET	OCU1_ OTD0	OCU8_ OTD0	PPG3_T OUT2	PPG5_T OUT0	PPG7_T OUT0
		RESSEL (8-15)	-	-	-	-	-	-	-	-
		PORTSE L (0-7)	-	-	-	-	-	-	-	-
		PORTSE L (8-15)	-	-	-	-	-	-	-	-
RIC_RE SIN498 (0x03E4)	ADC12B0 _HWTRG 8	RESSEL (0-7)	PORT_ PIN	RLT0_U FSET	RLT17_ UFSET	OCU2_ OTD0	OCU9_ OTD0	PPG4_T OUT0	PPG5_T OUT2	PPG7_T OUT2
		RESSEL (8-15)	-	-	-	-	-	-	-	-
		PORTSE L (0-7)	-	-	-	-	-	-	-	-
		PORTSE L (8-15)	-	-	-	-	-	-	-	-

Register (Offset)	Resource	RESSEL [3:0] /PORT SEL[3:0]	Source for Resource Input							
			0	1	2	3	4	5	6	7
			8	9	10	11	12	13	14	15
RIC_RE SIN499 (0x03E6)	ADC12B0 _HWTRG 9	RESSEL (0-7)	PORT_ PIN	RLT1_U FSET	RLT0_U FSET	OCU8_ OTD0	OCU10_ OTD0	PPG4_T OUT2	PPG6_T OUT0	PPG8_T OUT0
		RESSEL (8-15)	-	-	-	-	-	-	-	-
		PORTSE L (0-7)	-	-	-	-	-	-	-	-
		PORTSE L (8-15)	-	-	-	-	-	-	-	-
RIC_RE SIN500 (0x03E8)	ADC12B0 _HWTRG 10	RESSEL (0-7)	PORT_ PIN	RLT16_ UFSET	RLT1_U FSET	OCU9_ OTD0	OCU0_ OTD0	PPG5_T OUT0	PPG6_T OUT2	PPG8_T OUT2
		RESSEL (8-15)	-	-	-	-	-	-	-	-
		PORTSE L (0-7)	-	-	-	-	-	-	-	-
		PORTSE L (8-15)	-	-	-	-	-	-	-	-
RIC_RE SIN501 (0x03EA)	ADC12B0 _HWTRG 11	RESSEL (0-7)	PORT_ PIN	RLT17_ UFSET	RLT16_ UFSET	OCU10_ OTD0	OCU1_ OTD0	PPG5_T OUT2	PPG7_T OUT0	PPG9_T OUT0
		RESSEL (8-15)	-	-	-	-	-	-	-	-
		PORTSE L (0-7)	-	-	-	-	-	-	-	-
		PORTSE L (8-15)	-	-	-	-	-	-	-	-
RIC_RE SIN502 (0x03EC)	ADC12B0 _HWTRG 12	RESSEL (0-7)	PORT_ PIN	RLT0_U FSET	RLT1_U FSET	OCU0_ OTD0	OCU8_ OTD0	PPG6_T OUT0	PPG7_T OUT2	PPG9_T OUT2
		RESSEL (8-15)	-	-	-	-	-	-	-	-
		PORTSE L (0-7)	-	-	-	-	-	-	-	-
		PORTSE L (8-15)	-	-	-	-	-	-	-	-
RIC_RE SIN503 (0x03EE)	ADC12B0 _HWTRG 13	RESSEL (0-7)	PORT_ PIN	RLT1_U FSET	RLT16_ UFSET	OCU1_ OTD0	OCU9_ OTD0	PPG6_T OUT2	PPG8_T OUT0	PPG10_ TOUT0
		RESSEL (8-15)	-	-	-	-	-	-	-	-
		PORTSE L (0-7)	-	-	-	-	-	-	-	-
		PORTSE L (8-15)	-	-	-	-	-	-	-	-



Register (Offset)	Resource	RESSEL [3:0] /PORT SEL[3:0]	Source for Resource Input							
			0	1	2	3	4	5	6	7
			8	9	10	11	12	13	14	15
RIC_RE SIN504 (0x03F0)	ADC12B0 _HWTRG 14	RESSEL (0-7)	PORT_ PIN	RLT16_ UFSET	RLT17_ UFSET	OCU2_ OTD0	OCU10_ OTD0	PPG7_T OUT0	PPG8_T OUT2	PPG10_ TOUT2
		RESSEL (8-15)	-	-	-	-	-	-	-	-
		PORTSE L (0-7)	-	-	-	-	-	-	-	-
		PORTSE L (8-15)	-	-	-	-	-	-	-	-
RIC_RE SIN505 (0x03F2)	ADC12B0 _HWTRG 15	RESSEL (0-7)	PORT_ PIN	RLT17_ UFSET	RLT0_ FSET	OCU8_ OTD0	OCU0_ OTD0	PPG7_T OUT2	PPG9_T OUT0	PPG11_ TOUT0
		RESSEL (8-15)	-	-	-	-	-	-	-	-
		PORTSE L (0-7)	-	-	-	-	-	-	-	-
		PORTSE L (8-15)	-	-	-	-	-	-	-	-
RIC_RE SIN506 (0x03F4)	ADC12B0 _HWTRG 16	RESSEL (0-7)	PORT_ PIN	RLT0_ FSET	RLT16_ UFSET	OCU9_ OTD0	OCU1_ OTD0	PPG8_T OUT0	PPG9_T OUT2	PPG11_ TOUT2
		RESSEL (8-15)	-	-	-	-	-	-	-	-
		PORTSE L (0-7)	-	-	-	-	-	-	-	-
		PORTSE L (8-15)	-	-	-	-	-	-	-	-
RIC_RE SIN507 (0x03F6)	ADC12B0 _HWTRG 17	RESSEL (0-7)	PORT_ PIN	RLT1_ FSET	RLT17_ UFSET	OCU10_ OTD0	OCU2_ OTD0	PPG8_T OUT2	PPG10_ TOUT0	PPG12_ TOUT0
		RESSEL (8-15)	-	-	-	-	-	-	-	-
		PORTSE L (0-7)	-	-	-	-	-	-	-	-
		PORTSE L (8-15)	-	-	-	-	-	-	-	-
RIC_RE SIN508 (0x03F8)	ADC12B0 _HWTRG 18	RESSEL (0-7)	PORT_ PIN	RLT16_ UFSET	RLT0_ FSET	OCU0_ OTD0	OCU9_ OTD0	PPG9_T OUT0	PPG10_ TOUT2	PPG12_ TOUT2
		RESSEL (8-15)	-	-	-	-	-	-	-	-
		PORTSE L (0-7)	-	-	-	-	-	-	-	-
		PORTSE L (8-15)	-	-	-	-	-	-	-	-

Register (Offset)	Resource	RESSEL [3:0] /PORT SEL[3:0]	Source for Resource Input							
			0	1	2	3	4	5	6	7
			8	9	10	11	12	13	14	15
RIC_RE SIN509 (0x03FA)	ADC12B0_HWTRG 19	RESSEL (0-7)	PORT_ PIN	RLT17_ UFSET	RLT1_ U FSET	OCU1_ OTD0	OCU10_ OTD0	PPG9_ T OUT2	PPG11_ TOUT0	PPG13_ TOUT0
		RESSEL (8-15)	-	-	-	-	-	-	-	-
		PORTSE L (0-7)	-	-	-	-	-	-	-	-
		PORTSE L (8-15)	-	-	-	-	-	-	-	-
RIC_RE SIN510 (0x03FC)	ADC12B0_HWTRG 20	RESSEL (0-7)	PORT_ PIN	RLT0_ U FSET	RLT17_ UFSET	OCU2_ OTD0	OCU0_ OTD0	PPG10_ TOUT0	PPG11_ TOUT2	PPG13_ TOUT2
		RESSEL (8-15)	-	-	-	-	-	-	-	-
		PORTSE L (0-7)	-	-	-	-	-	-	-	-
		PORTSE L (8-15)	-	-	-	-	-	-	-	-
RIC_RE SIN511 (0x03FE)	ADC12B0_HWTRG 21	RESSEL (0-7)	PORT_ PIN	RLT1_ U FSET	RLT0_ U FSET	OCU8_ OTD0	OCU1_ OTD0	PPG10_ TOUT2	PPG12_ TOUT0	PPG14_ TOUT0
		RESSEL (8-15)	-	-	-	-	-	-	-	-
		PORTSE L (0-7)	-	-	-	-	-	-	-	-
		PORTSE L (8-15)	-	-	-	-	-	-	-	-
RIC_RE SIN512 (0x0400)	ADC12B0_HWTRG 22	RESSEL (0-7)	PORT_ PIN	RLT16_ UFSET	RLT1_ U FSET	OCU9_ OTD0	OCU2_ OTD0	PPG11_ TOUT0	PPG12_ TOUT2	PPG14_ TOUT2
		RESSEL (8-15)	-	-	-	-	-	-	-	-
		PORTSE L (0-7)	-	-	-	-	-	-	-	-
		PORTSE L (8-15)	-	-	-	-	-	-	-	-
RIC_RE SIN513 (0x0402)	ADC12B0_HWTRG 23	RESSEL (0-7)	PORT_ PIN	RLT17_ UFSET	RLT16_ UFSET	OCU10_ OTD0	OCU8_ OTD0	PPG11_ TOUT2	PPG13_ TOUT0	PPG15_ TOUT0
		RESSEL (8-15)	-	-	-	-	-	-	-	-
		PORTSE L (0-7)	-	-	-	-	-	-	-	-
		PORTSE L (8-15)	-	-	-	-	-	-	-	-

Register (Offset)	Resource	RESSEL [3:0] /PORT SEL[3:0]	Source for Resource Input							
			0	1	2	3	4	5	6	7
			8	9	10	11	12	13	14	15
RIC_RE SIN514 (0x0404)	ADC12B0 _HWTRG 24	RESSEL (0-7)	PORT_ PIN	RLT0_U FSET	RLT1_U FSET	OCU0_ OTD0	OCU10_ OTD0	PPG12_ TOUT0	PPG13_ TOUT2	PPG15_ TOUT2
		RESSEL (8-15)	-	-	-	-	-	-	-	-
		PORTSE L (0-7)	-	-	-	-	-	-	-	-
		PORTSE L (8-15)	-	-	-	-	-	-	-	-
RIC_RE SIN515 (0x0406)	ADC12B0 _HWTRG 25	RESSEL (0-7)	PORT_ PIN	RLT1_U FSET	RLT16_ UFSET	OCU1_ OTD0	OCU0_ OTD0	PPG12_ TOUT2	PPG14_ TOUT0	-
		RESSEL (8-15)	-	-	-	-	-	-	-	-
		PORTSE L (0-7)	-	-	-	-	-	-	-	-
		PORTSE L (8-15)	-	-	-	-	-	-	-	-
RIC_RE SIN516 (0x0408)	ADC12B0 _HWTRG 26	RESSEL (0-7)	PORT_ PIN	RLT16_ UFSET	RLT17_ UFSET	OCU2_ OTD0	OCU1_ OTD0	PPG13_ TOUT0	PPG14_ TOUT2	-
		RESSEL (8-15)	-	-	-	-	-	-	-	-
		PORTSE L (0-7)	-	-	-	-	-	-	-	-
		PORTSE L (8-15)	-	-	-	-	-	-	-	-
RIC_RE SIN517 (0x040A)	ADC12B0 _HWTRG 27	RESSEL (0-7)	PORT_ PIN	RLT17_ UFSET	RLT0_U FSET	OCU8_ OTD0	OCU2_ OTD0	PPG13_ TOUT2	PPG15_ TOUT0	-
		RESSEL (8-15)	-	-	-	-	-	-	-	-
		PORTSE L (0-7)	-	-	-	-	-	-	-	-
		PORTSE L (8-15)	-	-	-	-	-	-	-	-
RIC_RE SIN518 (0x040C)	ADC12B0 _HWTRG 28	RESSEL (0-7)	PORT_ PIN	RLT0_U FSET	RLT16_ UFSET	OCU9_ OTD0	OCU8_ OTD0	PPG14_ TOUT0	PPG15_ TOUT2	-
		RESSEL (8-15)	-	-	-	-	-	-	-	-
		PORTSE L (0-7)	-	-	-	-	-	-	-	-
		PORTSE L (8-15)	-	-	-	-	-	-	-	-

Register (Offset)	Resource	RESSEL [3:0] /PORT SEL[3:0]	Source for Resource Input							
			0	1	2	3	4	5	6	7
			8	9	10	11	12	13	14	15
RIC_RE SIN519 (0x040E)	ADC12B0 _HWTRG 29	RESSEL (0-7)	PORT_ PIN	RLT1_U FSET	RLT17_ UFSET	OCU10_ OTD0	OCU9_ OTD0	PPG14_ TOUT2	-	-
		RESSEL (8-15)	-	-	-	-	-	-	-	-
		PORTSE L (0-7)	-	-	-	-	-	-	-	-
		PORTSE L (8-15)	-	-	-	-	-	-	-	-
RIC_RE SIN520 (0x0410)	ADC12B0 _HWTRG 30	RESSEL (0-7)	PORT_ PIN	RLT16_ UFSET	RLT0_U FSET	OCU0_ OTD0	OCU1_ OTD0	PPG15_ TOUT0	-	-
		RESSEL (8-15)	-	-	-	-	-	-	-	-
		PORTSE L (0-7)	-	-	-	-	-	-	-	-
		PORTSE L (8-15)	-	-	-	-	-	-	-	-
RIC_RE SIN521 (0x0412)	ADC12B0 _HWTRG 31	RESSEL (0-7)	PORT_ PIN	RLT17_ UFSET	RLT1_U FSET	OCU1_ OTD0	OCU2_ OTD0	PPG15_ TOUT2	-	-
		RESSEL (8-15)	-	-	-	-	-	-	-	-
		PORTSE L (0-7)	-	-	-	-	-	-	-	-
		PORTSE L (8-15)	-	-	-	-	-	-	-	-
RIC_RE SIN522 (0x0414)	ADC12B0 _HWTRG 32	RESSEL (0-7)	PORT_ PIN	RLT0_U FSET	RLT17_ UFSET	OCU2_ OTD0	OCU8_ OTD0	-	-	-
		RESSEL (8-15)	-	-	-	-	-	-	-	-
		PORTSE L (0-7)	-	-	-	-	-	-	-	-
		PORTSE L (8-15)	-	-	-	-	-	-	-	-
RIC_RE SIN523 (0x0416)	ADC12B0 _HWTRG 33	RESSEL (0-7)	PORT_ PIN	RLT1_U FSET	RLT0_U FSET	OCU8_ OTD0	OCU9_ OTD0	-	-	-
		RESSEL (8-15)	-	-	-	-	-	-	-	-
		PORTSE L (0-7)	-	-	-	-	-	-	-	-
		PORTSE L (8-15)	-	-	-	-	-	-	-	-

Register (Offset)	Resource	RESSEL [3:0] /PORT SEL[3:0]	Source for Resource Input							
			0	1	2	3	4	5	6	7
			8	9	10	11	12	13	14	15
RIC_RE SIN524 (0x0418)	ADC12B0 _HWTRG 34	RESSEL (0-7)	PORT_ PIN	RLT16_ UFSET	RLT1_U FSET	OCU9_ OTD0	OCU10_ OTD0	-	-	-
		RESSEL (8-15)	-	-	-	-	-	-	-	-
		PORTSE L (0-7)	-	-	-	-	-	-	-	-
		PORTSE L (8-15)	-	-	-	-	-	-	-	-
RIC_RE SIN525 (0x041A)	ADC12B0 _HWTRG 35	RESSEL (0-7)	PORT_ PIN	RLT17_ UFSET	RLT16_ UFSET	OCU10_ OTD0	OCU0_ OTD0	-	-	-
		RESSEL (8-15)	-	-	-	-	-	-	-	-
		PORTSE L (0-7)	-	-	-	-	-	-	-	-
		PORTSE L (8-15)	-	-	-	-	-	-	-	-
RIC_RE SIN526 (0x041C)	ADC12B0 _HWTRG 36	RESSEL (0-7)	PORT_ PIN	RLT0_U FSET	RLT1_U FSET	OCU0_ OTD0	OCU2_ OTD0	-	-	-
		RESSEL (8-15)	-	-	-	-	-	-	-	-
		PORTSE L (0-7)	-	-	-	-	-	-	-	-
		PORTSE L (8-15)	-	-	-	-	-	-	-	-
RIC_RE SIN527 (0x041E)	ADC12B0 _HWTRG 37	RESSEL (0-7)	PORT_ PIN	RLT1_U FSET	RLT16_ UFSET	OCU1_ OTD0	OCU8_ OTD0	-	-	-
		RESSEL (8-15)	-	-	-	-	-	-	-	-
		PORTSE L (0-7)	-	-	-	-	-	-	-	-
		PORTSE L (8-15)	-	-	-	-	-	-	-	-
RIC_RE SIN528 (0x0420)	ADC12B0 _HWTRG 38	RESSEL (0-7)	PORT_ PIN	RLT16_ UFSET	RLT17_ UFSET	OCU2_ OTD0	OCU9_ OTD0	-	-	-
		RESSEL (8-15)	-	-	-	-	-	-	-	-
		PORTSE L (0-7)	-	-	-	-	-	-	-	-
		PORTSE L (8-15)	-	-	-	-	-	-	-	-

Register (Offset)	Resource	RESSEL [3:0] /PORT SEL[3:0]	Source for Resource Input							
			0	1	2	3	4	5	6	7
			8	9	10	11	12	13	14	15
RIC_RE SIN529 (0x0422)	ADC12B0 _HWTRG 39	RESSEL (0-7)	PORT_ PIN	RLT17_ UFSET	RLT0_ FSET	OCU8_ OTD0	OCU10_ OTD0	-	-	-
		RESSEL (8-15)	-	-	-	-	-	-	-	-
		PORTSE L (0-7)	-	-	-	-	-	-	-	-
		PORTSE L (8-15)	-	-	-	-	-	-	-	-
RIC_RE SIN530 (0x0424)	ADC12B0 _HWTRG 40	RESSEL (0-7)	PORT_ PIN	RLT0_ FSET	RLT16_ UFSET	OCU9_ OTD0	OCU0_ OTD0	-	-	-
		RESSEL (8-15)	-	-	-	-	-	-	-	-
		PORTSE L (0-7)	-	-	-	-	-	-	-	-
		PORTSE L (8-15)	-	-	-	-	-	-	-	-
RIC_RE SIN531 (0x0426)	ADC12B0 _HWTRG 41	RESSEL (0-7)	PORT_ PIN	RLT1_ FSET	RLT17_ UFSET	OCU10_ OTD0	OCU1_ OTD0	-	-	-
		RESSEL (8-15)	-	-	-	-	-	-	-	-
		PORTSE L (0-7)	-	-	-	-	-	-	-	-
		PORTSE L (8-15)	-	-	-	-	-	-	-	-
RIC_RE SIN532 (0x0428)	ADC12B0 _HWTRG 42	RESSEL (0-7)	PORT_ PIN	RLT16_ UFSET	RLT0_ FSET	OCU0_ OTD0	OCU8_ OTD0	-	-	-
		RESSEL (8-15)	-	-	-	-	-	-	-	-
		PORTSE L (0-7)	-	-	-	-	-	-	-	-
		PORTSE L (8-15)	-	-	-	-	-	-	-	-
RIC_RE SIN533 (0x042A)	ADC12B0 _HWTRG 43	RESSEL (0-7)	PORT_ PIN	RLT17_ UFSET	RLT1_ FSET	OCU1_ OTD0	OCU9_ OTD0	-	-	-
		RESSEL (8-15)	-	-	-	-	-	-	-	-
		PORTSE L (0-7)	-	-	-	-	-	-	-	-
		PORTSE L (8-15)	-	-	-	-	-	-	-	-

Register (Offset)	Resource	RESSEL [3:0] /PORT SEL[3:0]	Source for Resource Input							
			0	1	2	3	4	5	6	7
			8	9	10	11	12	13	14	15
RIC_RE SIN534 (0x042C)	ADC12B0 _HWTRG 44	RESSEL (0-7)	PORT_ PIN	RLT0_U FSET	RLT17_ UFSET	OCU2_ OTD0	OCU10_ OTD0	-	-	-
		RESSEL (8-15)	-	-	-	-	-	-	-	-
		PORTSE L (0-7)	-	-	-	-	-	-	-	-
		PORTSE L (8-15)	-	-	-	-	-	-	-	-
RIC_RE SIN535 (0x042E)	ADC12B0 _HWTRG 45	RESSEL (0-7)	PORT_ PIN	RLT1_U FSET	RLT0_U FSET	OCU8_ OTD0	OCU0_ OTD0	-	-	-
		RESSEL (8-15)	-	-	-	-	-	-	-	-
		PORTSE L (0-7)	-	-	-	-	-	-	-	-
		PORTSE L (8-15)	-	-	-	-	-	-	-	-
RIC_RE SIN536 (0x0430)	ADC12B0 _HWTRG 46	RESSEL (0-7)	PORT_ PIN	RLT16_ UFSET	RLT1_U FSET	OCU9_ OTD0	OCU1_ OTD0	-	-	-
		RESSEL (8-15)	-	-	-	-	-	-	-	-
		PORTSE L (0-7)	-	-	-	-	-	-	-	-
		PORTSE L (8-15)	-	-	-	-	-	-	-	-
RIC_RE SIN537 (0x0432)	ADC12B0 _HWTRG 47	RESSEL (0-7)	PORT_ PIN	RLT17_ UFSET	RLT16_ UFSET	OCU10_ OTD0	OCU2_ OTD0	-	-	-
		RESSEL (8-15)	-	-	-	-	-	-	-	-
		PORTSE L (0-7)	-	-	-	-	-	-	-	-
		PORTSE L (8-15)	-	-	-	-	-	-	-	-
RIC_RE SIN538 (0x0434)	ADC12B0 _HWTRG 48	RESSEL (0-7)	PORT_ PIN	RLT0_U FSET	RLT1_U FSET	OCU0_ OTD0	OCU9_ OTD0	-	-	-
		RESSEL (8-15)	-	-	-	-	-	-	-	-
		PORTSE L (0-7)	-	-	-	-	-	-	-	-
		PORTSE L (8-15)	-	-	-	-	-	-	-	-

Register (Offset)	Resource	RESSEL [3:0] /PORT SEL[3:0]	Source for Resource Input							
			0	1	2	3	4	5	6	7
			8	9	10	11	12	13	14	15
RIC_RE SIN539 (0x0436)	ADC12B0 _HWTRG 49	RESSEL (0-7)	PORT_ PIN	RLT1_U FSET	RLT16_ UFSET	OCU1_ OTD0	OCU10_ OTD0	-	-	-
		RESSEL (8-15)	-	-	-	-	-	-	-	-
		PORTSE L (0-7)	-	-	-	-	-	-	-	-
		PORTSE L (8-15)	-	-	-	-	-	-	-	-
RIC_RE SIN540 (0x0438)	ADC12B0 _HWTRG 50	RESSEL (0-7)	PORT_ PIN	RLT16_ UFSET	RLT17_ UFSET	OCU2_ OTD0	OCU0_ OTD0	-	-	-
		RESSEL (8-15)	-	-	-	-	-	-	-	-
		PORTSE L (0-7)	-	-	-	-	-	-	-	-
		PORTSE L (8-15)	-	-	-	-	-	-	-	-
RIC_RE SIN541 (0x043A)	ADC12B0 _HWTRG 51	RESSEL (0-7)	PORT_ PIN	RLT17_ UFSET	RLT0_U FSET	OCU8_ OTD0	OCU1_ OTD0	-	-	-
		RESSEL (8-15)	-	-	-	-	-	-	-	-
		PORTSE L (0-7)	-	-	-	-	-	-	-	-
		PORTSE L (8-15)	-	-	-	-	-	-	-	-
RIC_RE SIN542 (0x043C)	ADC12B0 _HWTRG 52	RESSEL (0-7)	PORT_ PIN	RLT0_U FSET	RLT16_ UFSET	OCU9_ OTD0	OCU2_ OTD0	-	-	-
		RESSEL (8-15)	-	-	-	-	-	-	-	-
		PORTSE L (0-7)	-	-	-	-	-	-	-	-
		PORTSE L (8-15)	-	-	-	-	-	-	-	-
RIC_RE SIN543 (0x043E)	ADC12B0 _HWTRG 53	RESSEL (0-7)	PORT_ PIN	RLT1_U FSET	RLT17_ UFSET	OCU10_ OTD0	OCU8_ OTD0	-	-	-
		RESSEL (8-15)	-	-	-	-	-	-	-	-
		PORTSE L (0-7)	-	-	-	-	-	-	-	-
		PORTSE L (8-15)	-	-	-	-	-	-	-	-



Register (Offset)	Resource	RESSEL [3:0] /PORT SEL[3:0]	Source for Resource Input									
			0	1	2	3	4	5	6	7		
			8	9	10	11	12	13	14	15		
RIC_RE SIN544 (0x0440)	ADC12B0 _HWTRG 54	RESSEL (0-7)	PORT_ PIN	RLT16_ UFSET	RLT0_ FSET	OCU0_ OTD0	OCU10_ OTD0	-	-	-	-	
		RESSEL (8-15)	-	-	-	-	-	-	-	-	-	
		PORTSE L (0-7)	-	-	-	-	-	-	-	-	-	
		PORTSE L (8-15)	-	-	-	-	-	-	-	-	-	
RIC_RE SIN545 (0x0442)	ADC12B0 _HWTRG 55	RESSEL (0-7)	PORT_ PIN	RLT17_ UFSET	RLT1_ FSET	OCU1_ OTD0	OCU0_ OTD0	-	-	-	-	
		RESSEL (8-15)	-	-	-	-	-	-	-	-	-	
		PORTSE L (0-7)	-	-	-	-	-	-	-	-	-	
		PORTSE L (8-15)	-	-	-	-	-	-	-	-	-	
RIC_RE SIN546 (0x0444)	ADC12B0 _HWTRG 56	RESSEL (0-7)	PORT_ PIN	RLT0_ FSET	RLT17_ UFSET	OCU2_ OTD0	OCU1_ OTD0	-	-	-	-	
		RESSEL (8-15)	-	-	-	-	-	-	-	-	-	
		PORTSE L (0-7)	-	-	-	-	-	-	-	-	-	
		PORTSE L (8-15)	-	-	-	-	-	-	-	-	-	
RIC_RE SIN547 (0x0446)	ADC12B0 _HWTRG 57	RESSEL (0-7)	PORT_ PIN	RLT1_ FSET	RLT0_ FSET	OCU8_ OTD0	OCU2_ OTD0	-	-	-	PPG0_T OUT0	
		RESSEL (8-15)	-	-	-	-	-	-	-	-	-	
		PORTSE L (0-7)	-	-	-	-	-	-	-	-	-	
		PORTSE L (8-15)	-	-	-	-	-	-	-	-	-	
RIC_RE SIN548 (0x0448)	ADC12B0 _HWTRG 58	RESSEL (0-7)	PORT_ PIN	RLT16_ UFSET	RLT1_ FSET	OCU9_ OTD0	OCU8_ OTD0	-	-	-	PPG0_T OUT2	
		RESSEL (8-15)	-	-	-	-	-	-	-	-	-	
		PORTSE L (0-7)	-	-	-	-	-	-	-	-	-	
		PORTSE L (8-15)	-	-	-	-	-	-	-	-	-	

Register (Offset)	Resource	RESSEL [3:0] /PORT SEL[3:0]	Source for Resource Input									
			0	1	2	3	4	5	6	7		
			8	9	10	11	12	13	14	15		
RIC_RE SIN549 (0x044A)	ADC12B0 _HWTRG 59	RESSEL (0-7)	PORT_ PIN	RLT17_ UFSET	RLT16_ UFSET	OCU10_ OTD0	OCU9_ OTD0	-	-	PPG1_T OUT0		
		RESSEL (8-15)	-	-	-	-	-	-	-	-		
		PORTSE L (0-7)	-	-	-	-	-	-	-	-		
		PORTSE L (8-15)	-	-	-	-	-	-	-	-		
RIC_RE SIN550 (0x044C)	ADC12B0 _HWTRG 60	RESSEL (0-7)	PORT_ PIN	RLT0_ FSET	RLT1_ FSET	OCU0_ OTD0	OCU1_ OTD0	-	-	PPG1_T OUT2		
		RESSEL (8-15)	-	-	-	-	-	-	-	-		
		PORTSE L (0-7)	-	-	-	-	-	-	-	-		
		PORTSE L (8-15)	-	-	-	-	-	-	-	-		
RIC_RE SIN551 (0x044E)	ADC12B0 _HWTRG 61	RESSEL (0-7)	PORT_ PIN	RLT1_ FSET	RLT16_ UFSET	OCU1_ OTD0	OCU2_ OTD0	-	PPG0_T OUT0	PPG2_T OUT0		
		RESSEL (8-15)	-	-	-	-	-	-	-	-		
		PORTSE L (0-7)	-	-	-	-	-	-	-	-		
		PORTSE L (8-15)	-	-	-	-	-	-	-	-		
RIC_RE SIN552 (0x0450)	ADC12B0 _HWTRG 62	RESSEL (0-7)	PORT_ PIN	RLT16_ UFSET	RLT17_ UFSET	OCU2_ OTD0	OCU8_ OTD0	-	PPG0_T OUT2	PPG2_T OUT2		
		RESSEL (8-15)	-	-	-	-	-	-	-	-		
		PORTSE L (0-7)	-	-	-	-	-	-	-	-		
		PORTSE L (8-15)	-	-	-	-	-	-	-	-		
RIC_RE SIN553 (0x0452)	ADC12B0 _HWTRG 63	RESSEL (0-7)	PORT_ PIN	RLT17_ UFSET	RLT0_ FSET	OCU8_ OTD0	OCU9_ OTD0	-	PPG1_T OUT0	PPG3_ OUT0		
		RESSEL (8-15)	-	-	-	-	-	-	-	-		
		PORTSE L (0-7)	-	-	-	-	-	-	-	-		
		PORTSE L (8-15)	-	-	-	-	-	-	-	-		

Register (Offset)	Resource	RESSEL [3:0] /PORT SEL[3:0]	Source for Resource Input							
			0	1	2	3	4	5	6	7
			8	9	10	11	12	13	14	15
RIC_RE SIN554 (0x0454)	ADC12B1_HWTRG 0	RESSEL (0-7)	PORT_ PIN	RLT0_U FSET	RLT1_U FSET	OCU0_ OTD0	OCU1_ OTD0	PPG0_T OUT0	PPG1_T OUT2	PPG3_T OUT2
		RESSEL (8-15)	-	-	-	-	-	-	-	-
		PORTSE L (0-7)	-	-	-	-	-	-	-	-
		PORTSE L (8-15)	-	-	-	-	-	-	-	-
RIC_RE SIN555 (0x0456)	ADC12B1_HWTRG 1	RESSEL (0-7)	PORT_ PIN	RLT1_U FSET	RLT16_ UFSET	OCU1_ OTD0	OCU2_ OTD0	PPG0_T OUT2	PPG2_T OUT0	PPG4_T OUT0
		RESSEL (8-15)	-	-	-	-	-	-	-	-
		PORTSE L (0-7)	-	-	-	-	-	-	-	-
		PORTSE L (8-15)	-	-	-	-	-	-	-	-
RIC_RE SIN556 (0x0458)	ADC12B1_HWTRG 2	RESSEL (0-7)	PORT_ PIN	RLT16_ UFSET	RLT17_ UFSET	OCU2_ OTD0	OCU8_ OTD0	PPG1_T OUT0	PPG2_T OUT2	PPG4_T OUT2
		RESSEL (8-15)	-	-	-	-	-	-	-	-
		PORTSE L (0-7)	-	-	-	-	-	-	-	-
		PORTSE L (8-15)	-	-	-	-	-	-	-	-
RIC_RE SIN557 (0x045A)	ADC12B1_HWTRG 3	RESSEL (0-7)	PORT_ PIN	RLT17_ UFSET	RLT0_U FSET	OCU8_ OTD0	OCU9_ OTD0	PPG1_T OUT2	PPG3_T OUT0	PPG5_T OUT0
		RESSEL (8-15)	-	-	-	-	-	-	-	-
		PORTSE L (0-7)	-	-	-	-	-	-	-	-
		PORTSE L (8-15)	-	-	-	-	-	-	-	-
RIC_RE SIN558 (0x045C)	ADC12B1_HWTRG 4	RESSEL (0-7)	PORT_ PIN	RLT0_U FSET	RLT16_ UFSET	OCU9_ OTD0	OCU10_ OTD0	PPG2_T OUT0	PPG3_T OUT2	PPG5_T OUT2
		RESSEL (8-15)	-	-	-	-	-	-	-	-
		PORTSE L (0-7)	-	-	-	-	-	-	-	-
		PORTSE L (8-15)	-	-	-	-	-	-	-	-

Register (Offset)	Resource	RESSEL [3:0] /PORT SEL[3:0]	Source for Resource Input							
			0	1	2	3	4	5	6	7
			8	9	10	11	12	13	14	15
RIC_RE SIN559 (0x045E)	ADC12B1 _HWTRG 5	RESSEL (0-7)	PORT_ PIN	RLT1_U FSET	RLT17_ UFSET	OCU10_ OTD0	OCU0_ OTD0	PPG2_T OUT2	PPG4_T OUT0	PPG6_T OUT0
		RESSEL (8-15)	-	-	-	-	-	-	-	-
		PORTSE L (0-7)	-	-	-	-	-	-	-	-
		PORTSE L (8-15)	-	-	-	-	-	-	-	-
RIC_RE SIN560 (0x0460)	ADC12B1 _HWTRG 6	RESSEL (0-7)	PORT_ PIN	RLT16_ UFSET	RLT0_U FSET	OCU0_ OTD0	OCU2_ OTD0	PPG3_T OUT0	PPG4_T OUT2	PPG6_T OUT2
		RESSEL (8-15)	-	-	-	-	-	-	-	-
		PORTSE L (0-7)	-	-	-	-	-	-	-	-
		PORTSE L (8-15)	-	-	-	-	-	-	-	-
RIC_RE SIN561 (0x0462)	ADC12B1 _HWTRG 7	RESSEL (0-7)	PORT_ PIN	RLT17_ UFSET	RLT1_U FSET	OCU1_ OTD0	OCU8_ OTD0	PPG3_T OUT2	PPG5_T OUT0	PPG7_T OUT0
		RESSEL (8-15)	-	-	-	-	-	-	-	-
		PORTSE L (0-7)	-	-	-	-	-	-	-	-
		PORTSE L (8-15)	-	-	-	-	-	-	-	-
RIC_RE SIN562 (0x0464)	ADC12B1 _HWTRG 8	RESSEL (0-7)	PORT_ PIN	RLT0_U FSET	RLT17_ UFSET	OCU2_ OTD0	OCU9_ OTD0	PPG4_T OUT0	PPG5_T OUT2	PPG7_T OUT2
		RESSEL (8-15)	-	-	-	-	-	-	-	-
		PORTSE L (0-7)	-	-	-	-	-	-	-	-
		PORTSE L (8-15)	-	-	-	-	-	-	-	-
RIC_RE SIN563 (0x0466)	ADC12B1 _HWTRG 9	RESSEL (0-7)	PORT_ PIN	RLT1_U FSET	RLT0_U FSET	OCU8_ OTD0	OCU10_ OTD0	PPG4_T OUT2	PPG6_T OUT0	PPG8_T OUT0
		RESSEL (8-15)	-	-	-	-	-	-	-	-
		PORTSE L (0-7)	-	-	-	-	-	-	-	-
		PORTSE L (8-15)	-	-	-	-	-	-	-	-

Register (Offset)	Resource	RESSEL [3:0] /PORT SEL[3:0]	Source for Resource Input							
			0	1	2	3	4	5	6	7
			8	9	10	11	12	13	14	15
RIC_RE SIN564 (0x0468)	ADC12B1_HWTRG 10	RESSEL (0-7)	PORT_ PIN	RLT16_ UFSET	RLT1_ U FSET	OCU9_ OTD0	OCU0_ OTD0	PPG5_ T OUT0	PPG6_ T OUT2	PPG8_ T OUT2
		RESSEL (8-15)	-	-	-	-	-	-	-	-
		PORTSE L (0-7)	-	-	-	-	-	-	-	-
		PORTSE L (8-15)	-	-	-	-	-	-	-	-
RIC_RE SIN565 (0x046A)	ADC12B1_HWTRG 11	RESSEL (0-7)	PORT_ PIN	RLT17_ UFSET	RLT16_ UFSET	OCU10_ OTD0	OCU1_ OTD0	PPG5_ T OUT2	PPG7_ T OUT0	PPG9_ T OUT0
		RESSEL (8-15)	-	-	-	-	-	-	-	-
		PORTSE L (0-7)	-	-	-	-	-	-	-	-
		PORTSE L (8-15)	-	-	-	-	-	-	-	-
RIC_RE SIN566 (0x046C)	ADC12B1_HWTRG 12	RESSEL (0-7)	PORT_ PIN	RLT0_ U FSET	RLT1_ U FSET	OCU0_ OTD0	OCU8_ OTD0	PPG6_ T OUT0	PPG7_ T OUT2	PPG9_ T OUT2
		RESSEL (8-15)	-	-	-	-	-	-	-	-
		PORTSE L (0-7)	-	-	-	-	-	-	-	-
		PORTSE L (8-15)	-	-	-	-	-	-	-	-
RIC_RE SIN567 (0x046E)	ADC12B1_HWTRG 13	RESSEL (0-7)	PORT_ PIN	RLT1_ U FSET	RLT16_ UFSET	OCU1_ OTD0	OCU9_ OTD0	PPG6_ T OUT2	PPG8_ T OUT0	PPG10_ TOUT0
		RESSEL (8-15)	-	-	-	-	-	-	-	-
		PORTSE L (0-7)	-	-	-	-	-	-	-	-
		PORTSE L (8-15)	-	-	-	-	-	-	-	-
RIC_RE SIN568 (0x0470)	ADC12B1_HWTRG 14	RESSEL (0-7)	PORT_ PIN	RLT16_ UFSET	RLT17_ UFSET	OCU2_ OTD0	OCU10_ OTD0	PPG7_ T OUT0	PPG8_ T OUT2	PPG10_ TOUT2
		RESSEL (8-15)	-	-	-	-	-	-	-	-
		PORTSE L (0-7)	-	-	-	-	-	-	-	-
		PORTSE L (8-15)	-	-	-	-	-	-	-	-

Register (Offset)	Resource	RESSEL [3:0] /PORT SEL[3:0]	Source for Resource Input							
			0	1	2	3	4	5	6	7
			8	9	10	11	12	13	14	15
RIC_RE SIN569 (0x0472)	ADC12B1 _HWTRG 15	RESSEL (0-7)	PORT_ PIN	RLT17_ UFSET	RLT0_ FSET	OCU8_ OTD0	OCU0_ OTD0	PPG7_ T OUT2	PPG9_ T OUT0	PPG11_ T TOUT0
		RESSEL (8-15)	-	-	-	-	-	-	-	-
		PORTSE L (0-7)	-	-	-	-	-	-	-	-
		PORTSE L (8-15)	-	-	-	-	-	-	-	-
RIC_RE SIN570 (0x0474)	ADC12B1 _HWTRG 16	RESSEL (0-7)	PORT_ PIN	RLT0_ FSET	RLT16_ UFSET	OCU9_ OTD0	OCU1_ OTD0	PPG8_ T OUT0	PPG9_ T OUT2	PPG11_ T TOUT2
		RESSEL (8-15)	-	-	-	-	-	-	-	-
		PORTSE L (0-7)	-	-	-	-	-	-	-	-
		PORTSE L (8-15)	-	-	-	-	-	-	-	-
RIC_RE SIN571 (0x0476)	ADC12B1 _HWTRG 17	RESSEL (0-7)	PORT_ PIN	RLT1_ FSET	RLT17_ UFSET	OCU10_ OTD0	OCU2_ OTD0	PPG8_ T OUT2	PPG10_ T TOUT0	PPG12_ T TOUT0
		RESSEL (8-15)	-	-	-	-	-	-	-	-
		PORTSE L (0-7)	-	-	-	-	-	-	-	-
		PORTSE L (8-15)	-	-	-	-	-	-	-	-
RIC_RE SIN572 (0x0478)	ADC12B1 _HWTRG 18	RESSEL (0-7)	PORT_ PIN	RLT16_ UFSET	RLT0_ FSET	OCU0_ OTD0	OCU9_ OTD0	PPG9_ T OUT0	PPG10_ T TOUT2	PPG12_ T TOUT2
		RESSEL (8-15)	-	-	-	-	-	-	-	-
		PORTSE L (0-7)	-	-	-	-	-	-	-	-
		PORTSE L (8-15)	-	-	-	-	-	-	-	-
RIC_RE SIN573 (0x047A)	ADC12B1 _HWTRG 19	RESSEL (0-7)	PORT_ PIN	RLT17_ UFSET	RLT1_ FSET	OCU1_ OTD0	OCU10_ OTD0	PPG9_ T OUT2	PPG11_ T TOUT0	PPG13_ T TOUT0
		RESSEL (8-15)	-	-	-	-	-	-	-	-
		PORTSE L (0-7)	-	-	-	-	-	-	-	-
		PORTSE L (8-15)	-	-	-	-	-	-	-	-

Register (Offset)	Resource	RESSEL [3:0] /PORT SEL[3:0]	Source for Resource Input							
			0	1	2	3	4	5	6	7
			8	9	10	11	12	13	14	15
RIC_RE SIN574 (0x047C)	ADC12B1 _HWTRG 20	RESSEL (0-7)	PORT_ PIN	RLT0_U FSET	RLT17_ UFSET	OCU2_ OTD0	OCU0_ OTD0	PPG10_ TOUT0	PPG11_ TOUT2	PPG13_ TOUT2
		RESSEL (8-15)	-	-	-	-	-	-	-	-
		PORTSE L (0-7)	-	-	-	-	-	-	-	-
		PORTSE L (8-15)	-	-	-	-	-	-	-	-
RIC_RE SIN575 (0x047E)	ADC12B1 _HWTRG 21	RESSEL (0-7)	PORT_ PIN	RLT1_U FSET	RLT0_U FSET	OCU8_ OTD0	OCU1_ OTD0	PPG10_ TOUT2	PPG12_ TOUT0	PPG14_ TOUT0
		RESSEL (8-15)	-	-	-	-	-	-	-	-
		PORTSE L (0-7)	-	-	-	-	-	-	-	-
		PORTSE L (8-15)	-	-	-	-	-	-	-	-
RIC_RE SIN576 (0x0480)	ADC12B1 _HWTRG 22	RESSEL (0-7)	PORT_ PIN	RLT16_ UFSET	RLT1_U FSET	OCU9_ OTD0	OCU2_ OTD0	PPG11_ TOUT0	PPG12_ TOUT2	PPG14_ TOUT2
		RESSEL (8-15)	-	-	-	-	-	-	-	-
		PORTSE L (0-7)	-	-	-	-	-	-	-	-
		PORTSE L (8-15)	-	-	-	-	-	-	-	-
RIC_RE SIN577 (0x0482)	ADC12B1 _HWTRG 23	RESSEL (0-7)	PORT_ PIN	RLT17_ UFSET	RLT16_ UFSET	OCU10_ OTD0	OCU8_ OTD0	PPG11_ TOUT2	PPG13_ TOUT0	PPG15_ TOUT0
		RESSEL (8-15)	-	-	-	-	-	-	-	-
		PORTSE L (0-7)	-	-	-	-	-	-	-	-
		PORTSE L (8-15)	-	-	-	-	-	-	-	-
RIC_RE SIN578 (0x0484)	ADC12B1 _HWTRG 24	RESSEL (0-7)	PORT_ PIN	RLT0_U FSET	RLT1_U FSET	OCU0_ OTD0	OCU10_ OTD0	PPG12_ TOUT0	PPG13_ TOUT2	PPG15_ TOUT2
		RESSEL (8-15)	-	-	-	-	-	-	-	-
		PORTSE L (0-7)	-	-	-	-	-	-	-	-
		PORTSE L (8-15)	-	-	-	-	-	-	-	-

Register (Offset)	Resource	RESSEL [3:0] /PORT SEL[3:0]	Source for Resource Input							
			0	1	2	3	4	5	6	7
			8	9	10	11	12	13	14	15
RIC_RE SIN579 (0x0486)	ADC12B1 _HWTRG 25	RESSEL (0-7)	PORT_ PIN	RLT1_U FSET	RLT16_ UFSET	OCU1_ OTD0	OCU0_ OTD0	PPG12_ TOUT2	PPG14_ TOUT0	-
		RESSEL (8-15)	-	-	-	-	-	-	-	-
		PORTSE L (0-7)	-	-	-	-	-	-	-	-
		PORTSE L (8-15)	-	-	-	-	-	-	-	-
RIC_RE SIN580 (0x0488)	ADC12B1 _HWTRG 26	RESSEL (0-7)	PORT_ PIN	RLT16_ UFSET	RLT17_ UFSET	OCU2_ OTD0	OCU1_ OTD0	PPG13_ TOUT0	PPG14_ TOUT2	-
		RESSEL (8-15)	-	-	-	-	-	-	-	-
		PORTSE L (0-7)	-	-	-	-	-	-	-	-
		PORTSE L (8-15)	-	-	-	-	-	-	-	-
RIC_RE SIN581 (0x048A)	ADC12B1 _HWTRG 27	RESSEL (0-7)	PORT_ PIN	RLT17_ UFSET	RLT0_U FSET	OCU8_ OTD0	OCU2_ OTD0	PPG13_ TOUT2	PPG15_ TOUT0	-
		RESSEL (8-15)	-	-	-	-	-	-	-	-
		PORTSE L (0-7)	-	-	-	-	-	-	-	-
		PORTSE L (8-15)	-	-	-	-	-	-	-	-
RIC_RE SIN582 (0x048C)	ADC12B1 _HWTRG 28	RESSEL (0-7)	PORT_ PIN	RLT0_U FSET	RLT16_ UFSET	OCU9_ OTD0	OCU8_ OTD0	PPG14_ TOUT0	PPG15_ TOUT2	-
		RESSEL (8-15)	-	-	-	-	-	-	-	-
		PORTSE L (0-7)	-	-	-	-	-	-	-	-
		PORTSE L (8-15)	-	-	-	-	-	-	-	-
RIC_RE SIN583 (0x048E)	ADC12B1 _HWTRG 29	RESSEL (0-7)	PORT_ PIN	RLT1_U FSET	RLT17_ UFSET	OCU10_ OTD0	OCU9_ OTD0	PPG14_ TOUT2	-	-
		RESSEL (8-15)	-	-	-	-	-	-	-	-
		PORTSE L (0-7)	-	-	-	-	-	-	-	-
		PORTSE L (8-15)	-	-	-	-	-	-	-	-



Register (Offset)	Resource	RESSEL [3:0] /PORT SEL[3:0]	Source for Resource Input							
			0	1	2	3	4	5	6	7
			8	9	10	11	12	13	14	15
RIC_RE SIN584 (0x0490)	ADC12B1 _HWTRG 30	RESSEL (0-7)	PORT_ PIN	RLT16_ UFSET	RLT0_ FSET	OCU0_ OTD0	OCU1_ OTD0	PPG15_ TOUT0	-	-
		RESSEL (8-15)	-	-	-	-	-	-	-	-
		PORTSE L (0-7)	-	-	-	-	-	-	-	-
		PORTSE L (8-15)	-	-	-	-	-	-	-	-
RIC_RE SIN585 (0x0492)	ADC12B1 _HWTRG 31	RESSEL (0-7)	PORT_ PIN	RLT17_ UFSET	RLT1_ FSET	OCU1_ OTD0	OCU2_ OTD0	PPG15_ TOUT2	-	-
		RESSEL (8-15)	-	-	-	-	-	-	-	-
		PORTSE L (0-7)	-	-	-	-	-	-	-	-
		PORTSE L (8-15)	-	-	-	-	-	-	-	-
RIC_RE SIN586 (0x0494)	ADC12B1 _HWTRG 32	RESSEL (0-7)	PORT_ PIN	RLT0_ FSET	RLT17_ UFSET	OCU2_ OTD0	OCU8_ OTD0	-	-	-
		RESSEL (8-15)	-	-	-	-	-	-	-	-
		PORTSE L (0-7)	-	-	-	-	-	-	-	-
		PORTSE L (8-15)	-	-	-	-	-	-	-	-
RIC_RE SIN587 (0x0496)	ADC12B1 _HWTRG 33	RESSEL (0-7)	PORT_ PIN	RLT1_ FSET	RLT0_ FSET	OCU8_ OTD0	OCU9_ OTD0	-	-	-
		RESSEL (8-15)	-	-	-	-	-	-	-	-
		PORTSE L (0-7)	-	-	-	-	-	-	-	-
		PORTSE L (8-15)	-	-	-	-	-	-	-	-
RIC_RE SIN588 (0x0498)	ADC12B1 _HWTRG 34	RESSEL (0-7)	PORT_ PIN	RLT16_ UFSET	RLT1_ FSET	OCU9_ OTD0	OCU10_ OTD0	-	-	-
		RESSEL (8-15)	-	-	-	-	-	-	-	-
		PORTSE L (0-7)	-	-	-	-	-	-	-	-
		PORTSE L (8-15)	-	-	-	-	-	-	-	-

Register (Offset)	Resource	RESSEL [3:0] /PORT SEL[3:0]	Source for Resource Input							
			0	1	2	3	4	5	6	7
			8	9	10	11	12	13	14	15
RIC_RE SIN589 (0x049A)	ADC12B1_HWTRG 35	RESSEL (0-7)	PORT_ PIN	RLT17_ UFSET	RLT16_ UFSET	OCU10_ OTD0	OCU0_ OTD0	-	-	-
		RESSEL (8-15)	-	-	-	-	-	-	-	-
		PORTSE L (0-7)	-	-	-	-	-	-	-	-
		PORTSE L (8-15)	-	-	-	-	-	-	-	-
RIC_RE SIN590 (0x049C)	ADC12B1_HWTRG 36	RESSEL (0-7)	PORT_ PIN	RLT0_ U FSET	RLT1_ U FSET	OCU0_ OTD0	OCU2_ OTD0	-	-	-
		RESSEL (8-15)	-	-	-	-	-	-	-	-
		PORTSE L (0-7)	-	-	-	-	-	-	-	-
		PORTSE L (8-15)	-	-	-	-	-	-	-	-
RIC_RE SIN591 (0x049E)	ADC12B1_HWTRG 37	RESSEL (0-7)	PORT_ PIN	RLT1_ U FSET	RLT16_ UFSET	OCU1_ OTD0	OCU8_ OTD0	-	-	-
		RESSEL (8-15)	-	-	-	-	-	-	-	-
		PORTSE L (0-7)	-	-	-	-	-	-	-	-
		PORTSE L (8-15)	-	-	-	-	-	-	-	-
RIC_RE SIN592 (0x04A0)	ADC12B1_HWTRG 38	RESSEL (0-7)	PORT_ PIN	RLT16_ UFSET	RLT17_ UFSET	OCU2_ OTD0	OCU9_ OTD0	-	-	-
		RESSEL (8-15)	-	-	-	-	-	-	-	-
		PORTSE L (0-7)	-	-	-	-	-	-	-	-
		PORTSE L (8-15)	-	-	-	-	-	-	-	-
RIC_RE SIN593 (0x04A2)	ADC12B1_HWTRG 39	RESSEL (0-7)	PORT_ PIN	RLT17_ UFSET	RLT0_ U FSET	OCU8_ OTD0	OCU10_ OTD0	-	-	-
		RESSEL (8-15)	-	-	-	-	-	-	-	-
		PORTSE L (0-7)	-	-	-	-	-	-	-	-
		PORTSE L (8-15)	-	-	-	-	-	-	-	-

Register (Offset)	Resource	RESSEL [3:0] /PORT SEL[3:0]	Source for Resource Input							
			0	1	2	3	4	5	6	7
			8	9	10	11	12	13	14	15
RIC_RE SIN594 (0x04A4)	ADC12B1 _HWTRG 40	RESSEL (0-7)	PORT_ PIN	RLT0_U FSET	RLT16_ UFSET	OCU9_ OTD0	OCU0_ OTD0	-	-	-
		RESSEL (8-15)	-	-	-	-	-	-	-	-
		PORTSE L (0-7)	-	-	-	-	-	-	-	-
		PORTSE L (8-15)	-	-	-	-	-	-	-	-
RIC_RE SIN595 (0x04A6)	ADC12B1 _HWTRG 41	RESSEL (0-7)	PORT_ PIN	RLT1_U FSET	RLT17_ UFSET	OCU10_ OTD0	OCU1_ OTD0	-	-	-
		RESSEL (8-15)	-	-	-	-	-	-	-	-
		PORTSE L (0-7)	-	-	-	-	-	-	-	-
		PORTSE L (8-15)	-	-	-	-	-	-	-	-
RIC_RE SIN596 (0x04A8)	ADC12B1 _HWTRG 42	RESSEL (0-7)	PORT_ PIN	RLT16_ UFSET	RLT0_U FSET	OCU0_ OTD0	OCU8_ OTD0	-	-	-
		RESSEL (8-15)	-	-	-	-	-	-	-	-
		PORTSE L (0-7)	-	-	-	-	-	-	-	-
		PORTSE L (8-15)	-	-	-	-	-	-	-	-
RIC_RE SIN597 (0x04AA)	ADC12B1 _HWTRG 43	RESSEL (0-7)	PORT_ PIN	RLT17_ UFSET	RLT1_U FSET	OCU1_ OTD0	OCU9_ OTD0	-	-	-
		RESSEL (8-15)	-	-	-	-	-	-	-	-
		PORTSE L (0-7)	-	-	-	-	-	-	-	-
		PORTSE L (8-15)	-	-	-	-	-	-	-	-
RIC_RE SIN598 (0x04AC)	ADC12B1 _HWTRG 44	RESSEL (0-7)	PORT_ PIN	RLT0_U FSET	RLT17_ UFSET	OCU2_ OTD0	OCU10_ OTD0	-	-	-
		RESSEL (8-15)	-	-	-	-	-	-	-	-
		PORTSE L (0-7)	-	-	-	-	-	-	-	-
		PORTSE L (8-15)	-	-	-	-	-	-	-	-

Register (Offset)	Resource	RESSEL [3:0] /PORT SEL[3:0]	Source for Resource Input							
			0	1	2	3	4	5	6	7
			8	9	10	11	12	13	14	15
RIC_RE SIN599 (0x04AE)	ADC12B1_HWTRG 45	RESSEL (0-7)	PORT_ PIN	RLT1_U FSET	RLT0_U FSET	OCU8_ OTD0	OCU0_ OTD0	-	-	--
		RESSEL (8-15)	-	-	-	-	-	-	-	-
		PORTSE L (0-7)	-	-	-	-	-	-	-	-
		PORTSE L (8-15)	-	-	-	-	-	-	-	-
RIC_RE SIN600 (0x04B0)	ADC12B1_HWTRG 46	RESSEL (0-7)	PORT_ PIN	RLT16_ UFSET	RLT1_U FSET	OCU9_ OTD0	OCU1_ OTD0	-	-	-
		RESSEL (8-15)	-	-	-	-	-	-	-	-
		PORTSE L (0-7)	-	-	-	-	-	-	-	-
		PORTSE L (8-15)	-	-	-	-	-	-	-	-
RIC_RE SIN601 (0x04B2)	ADC12B1_HWTRG 47	RESSEL (0-7)	PORT_ PIN	RLT17_ UFSET	RLT16_ UFSET	OCU10_ OTD0	OCU2_ OTD0	-	-	-
		RESSEL (8-15)	-	-	-	-	-	-	-	-
		PORTSE L (0-7)	-	-	-	-	-	-	-	-
		PORTSE L (8-15)	-	-	-	-	-	-	-	-
RIC_RE SIN602 (0x04B4)	ADC12B1_HWTRG 48	RESSEL (0-7)	PORT_ PIN	RLT0_U FSET	RLT1_U FSET	OCU0_ OTD0	OCU9_ OTD0	-	-	-
		RESSEL (8-15)	-	-	-	-	-	-	-	-
		PORTSE L (0-7)	-	-	-	-	-	-	-	-
		PORTSE L (8-15)	-	-	-	-	-	-	-	-
RIC_RE SIN603 (0x04B6)	ADC12B1_HWTRG 49	RESSEL (0-7)	PORT_ PIN	RLT1_U FSET	RLT16_ UFSET	OCU1_ OTD0	OCU10_ OTD0	-	-	-
		RESSEL (8-15)	-	-	-	-	-	-	-	-
		PORTSE L (0-7)	-	-	-	-	-	-	-	-
		PORTSE L (8-15)	-	-	-	-	-	-	-	-

Register (Offset)	Resource	RESSEL [3:0] /PORT SEL[3:0]	Source for Resource Input							
			0	1	2	3	4	5	6	7
			8	9	10	11	12	13	14	15
RIC_RE SIN604 (0x04B8)	ADC12B1 _HWTRG 50	RESSEL (0-7)	PORT_ PIN	RLT16_ UFSET	RLT17_ UFSET	OCU2_ OTD0	OCU0_ OTD0	-	-	-
		RESSEL (8-15)	-	-	-	-	-	-	-	-
		PORTSE L (0-7)	-	-	-	-	-	-	-	-
		PORTSE L (8-15)	-	-	-	-	-	-	-	-
RIC_RE SIN605 (0x04BA)	ADC12B1 _HWTRG 51	RESSEL (0-7)	PORT_ PIN	RLT17_ UFSET	RLT0_ FSET	OCU8_ OTD0	OCU1_ OTD0	-	-	-
		RESSEL (8-15)	-	-	-	-	-	-	-	-
		PORTSE L (0-7)	-	-	-	-	-	-	-	-
		PORTSE L (8-15)	-	-	-	-	-	-	-	-
RIC_RE SIN606 (0x04BC)	ADC12B1 _HWTRG 52	RESSEL (0-7)	PORT_ PIN	RLT0_ FSET	RLT16_ UFSET	OCU9_ OTD0	OCU2_ OTD0	-	-	-
		RESSEL (8-15)	-	-	-	-	-	-	-	-
		PORTSE L (0-7)	-	-	-	-	-	-	-	-
		PORTSE L (8-15)	-	-	-	-	-	-	-	-
RIC_RE SIN607 (0x04BE)	ADC12B1 _HWTRG 53	RESSEL (0-7)	PORT_ PIN	RLT1_ FSET	RLT17_ UFSET	OCU10_ OTD0	OCU8_ OTD0	-	-	-
		RESSEL (8-15)	-	-	-	-	-	-	-	-
		PORTSE L (0-7)	-	-	-	-	-	-	-	-
		PORTSE L (8-15)	-	-	-	-	-	-	-	-
RIC_RE SIN608 (0x04C0)	ADC12B1 _HWTRG 54	RESSEL (0-7)	PORT_ PIN	RLT16_ UFSET	RLT0_ FSET	OCU0_ OTD0	OCU10_ OTD0	-	-	-
		RESSEL (8-15)	-	-	-	-	-	-	-	-
		PORTSE L (0-7)	-	-	-	-	-	-	-	-
		PORTSE L (8-15)	-	-	-	-	-	-	-	-

Register (Offset)	Resource	RESSEL [3:0] /PORT SEL[3:0]	Source for Resource Input							
			0	1	2	3	4	5	6	7
			8	9	10	11	12	13	14	15
RIC_RE SIN609 (0x04C2)	ADC12B1 _HWTRG 55	RESSEL (0-7)	PORT_ PIN	RLT17_ UFSET	RLT1_U FSET	OCU1_ OTD0	OCU0_ OTD0	-	-	-
		RESSEL (8-15)	-	-	-	-	-	-	-	-
		PORTSE L (0-7)	-	-	-	-	-	-	-	-
		PORTSE L (8-15)	-	-	-	-	-	-	-	-
RIC_RE SIN610 (0x04C4)	ADC12B1 _HWTRG 56	RESSEL (0-7)	PORT_ PIN	RLT0_U FSET	RLT17_ UFSET	OCU2_ OTD0	OCU1_ OTD0	-	-	-
		RESSEL (8-15)	-	-	-	-	-	-	-	-
		PORTSE L (0-7)	-	-	-	-	-	-	-	-
		PORTSE L (8-15)	-	-	-	-	-	-	-	-
RIC_RE SIN611 (0x04C6)	ADC12B1 _HWTRG 57	RESSEL (0-7)	PORT_ PIN	RLT1_U FSET	RLT0_U FSET	OCU8_ OTD0	OCU2_ OTD0	-	-	-
		RESSEL (8-15)	-	-	-	-	-	-	-	-
		PORTSE L (0-7)	-	-	-	-	-	-	-	-
		PORTSE L (8-15)	-	-	-	-	-	-	-	-
RIC_RE SIN612 (0x04C8)	ADC12B1 _HWTRG 58	RESSEL (0-7)	PORT_ PIN	RLT16_ UFSET	RLT1_U FSET	OCU9_ OTD0	OCU8_ OTD0	-	-	-
		RESSEL (8-15)	-	-	-	-	-	-	-	-
		PORTSE L (0-7)	-	-	-	-	-	-	-	-
		PORTSE L (8-15)	-	-	-	-	-	-	-	-
RIC_RE SIN613 (0x04CA)	ADC12B1 _HWTRG 59	RESSEL (0-7)	PORT_ PIN	RLT17_ UFSET	RLT16_ UFSET	OCU10_ OTD0	OCU9_ OTD0	-	-	-
		RESSEL (8-15)	-	-	-	-	-	-	-	-
		PORTSE L (0-7)	-	-	-	-	-	-	-	-
		PORTSE L (8-15)	-	-	-	-	-	-	-	-

Register (Offset)	Resource	RESSEL [3:0] /PORT SEL[3:0]	Source for Resource Input									
			0	1	2	3	4	5	6	7		
			8	9	10	11	12	13	14	15		
RIC_RE SIN614 (0x04CC)	ADC12B1 _HWTRG 60	RESSEL (0-7)	PORT_ PIN	RLT0_U FSET	RLT1_U FSET	OCU0_ OTD0	OCU1_ OTD0	-	-	PPG1_T OUT2		
		RESSEL (8-15)	-	-	-	-	-	-	-	-		
		PORTSE L (0-7)	-	-	-	-	-	-	-	-		
		PORTSE L (8-15)	-	-	-	-	-	-	-	-		
RIC_RE SIN615 (0x04CE)	ADC12B1 _HWTRG 61	RESSEL (0-7)	PORT_ PIN	RLT1_U FSET	RLT16_ UFSET	OCU1_ OTD0	OCU2_ OTD0	-	PPG0_T OUT0	PPG2_T OUT0		
		RESSEL (8-15)	-	-	-	-	-	-	-	-		
		PORTSE L (0-7)	-	-	-	-	-	-	-	-		
		PORTSE L (8-15)	-	-	-	-	-	-	-	-		
RIC_RE SIN616 (0x04D0)	ADC12B1 _HWTRG 62	RESSEL (0-7)	PORT_ PIN	RLT16_ UFSET	RLT17_ UFSET	OCU2_ OTD0	OCU8_ OTD0	-	PPG0_T OUT2	PPG2_T OUT2		
		RESSEL (8-15)	-	-	-	-	-	-	-	-		
		PORTSE L (0-7)	-	-	-	-	-	-	-	-		
		PORTSE L (8-15)	-	-	-	-	-	-	-	-		
RIC_RE SIN617 (0x04D2)	ADC12B1 _HWTRG 63	RESSEL (0-7)	PORT_ PIN	RLT17_ UFSET	RLT0_U FSET	OCU8_ OTD0	OCU9_ OTD0	-	PPG1_T OUT0	PPG3_T OUT0		
		RESSEL (8-15)	-	-	-	-	-	-	-	-		
		PORTSE L (0-7)	-	-	-	-	-	-	-	-		
		PORTSE L (8-15)	-	-	-	-	-	-	-	-		

Register (Offset)	Resource	RESSEL [3:0] /PORT SEL[3:0]	Source for Resource Input							
			0	1	2	3	4	5	6	7
			8	9	10	11	12	13	14	15
RIC_RE SIN626 (0x04E4)	DDRHSS PI_MSTA RT	RESSEL (0-7)	-	TOT0	TOT16	-	-	-	-	-
		RESSEL (8-15)	-	-	-	-	-	-	-	-
		PORTSE L (0-7)	-	-	-	-	-	-	-	-
		PORTSE L (8-15)	-	-	-	-	-	-	-	-
RIC_RE SIN629 (0x04EA)	MDIO	RESSEL (0-7)	-	-	-	-	-	-	-	-
		RESSEL (8-15)	-	-	-	-	-	-	-	-
		PORTSE L (0-7)	P0_31	P3_06	-	-	-	-	-	-
		PORTSE L (8-15)	-	-	-	-	-	-	-	-
RIC_RE SIN630 (0x04EC)	CRS	RESSEL (0-7)	-	-	-	-	-	-	-	-
		RESSEL (8-15)	-	-	-	-	-	-	-	-
		PORTSE L (0-7)	P1_02	P0_20	-	-	-	-	-	-
		PORTSE L (8-15)	-	-	-	-	-	-	-	-
RIC_RE SIN631 (0x04EE)	RXD0	RESSEL (0-7)	-	-	-	-	-	-	-	-
		RESSEL (8-15)	-	-	-	-	-	-	-	-
		PORTSE L (0-7)	P0_27	P3_04	-	-	-	-	-	-
		PORTSE L (8-15)	-	-	-	-	-	-	-	-
RIC_RE SIN632 (0x04F0)	RXD1	RESSEL (0-7)	-	-	-	-	-	-	-	-
		RESSEL (8-15)	-	-	-	-	-	-	-	-
		PORTSE L (0-7)	P0_28	P4_06	-	-	-	-	-	-
		PORTSE L (8-15)	-	-	-	-	-	-	-	-



Register (Offset)	Resource	RESSEL [3:0] /PORT SEL[3:0]	Source for Resource Input									
			0	1	2	3	4	5	6	7		
			8	9	10	11	12	13	14	15		
RIC_RE SIN633 (0x04F2)	RXD2	RESSEL (0-7)	-	-	-	-	-	-	-	-	-	
		RESSEL (8-15)	-	-	-	-	-	-	-	-	-	
		PORTSE L (0-7)	P0_29	P4_07	-	-	-	-	-	-	-	
		PORTSE L (8-15)	-	-	-	-	-	-	-	-	-	
RIC_RE SIN634 (0x04F4)	RXD3	RESSEL (0-7)	-	-	-	-	-	-	-	-	-	
		RESSEL (8-15)	-	-	-	-	-	-	-	-	-	
		PORTSE L (0-7)	P0_30	P3_05	-	-	-	-	-	-	-	
		PORTSE L (8-15)	-	-	-	-	-	-	-	-	-	
RIC_RE SIN635 (0x04F6)	COL	RESSEL (0-7)	-	-	-	-	-	-	-	-	-	
		RESSEL (8-15)	-	-	-	-	-	-	-	-	-	
		PORTSE L (0-7)	P1_01	P0_19	-	-	-	-	-	-	-	
		PORTSE L (8-15)	-	-	-	-	-	-	-	-	-	
RIC_RE SIN636 (0x04F8)	RXDV	RESSEL (0-7)	-	-	-	-	-	-	-	-	-	
		RESSEL (8-15)	-	-	-	-	-	-	-	-	-	
		PORTSE L (0-7)	P0_19	P4_02	-	-	-	-	-	-	-	
		PORTSE L (8-15)	-	-	-	-	-	-	-	-	-	
RIC_RE SIN637 (0x04FA)	RXER	RESSEL (0-7)	-	-	-	-	-	-	-	-	-	
		RESSEL (8-15)	-	-	-	-	-	-	-	-	-	
		PORTSE L (0-7)	P0_18	P4_01	-	-	-	-	-	-	-	
		PORTSE L (8-15)	-	-	-	-	-	-	-	-	-	

Register (Offset)	Resource	RESSEL [3:0] /PORT SEL[3:0]	Source for Resource Input							
			0	1	2	3	4	5	6	7
			8	9	10	11	12	13	14	15
RIC_RE SIN638 (0x04FC)	RXCLK	RESSEL (0-7)	-	-	-	-	-	-	-	-
		RESSEL (8-15)	-	-	-	-	-	-	-	-
		PORTSE L (0-7)	P0_17	P4_00	-	-	-	-	-	-
		PORTSE L (8-15)	-	-	-	-	-	-	-	-
RIC_RE SIN639 (0x04FE)	TXCLK	RESSEL (0-7)	-	-	-	-	-	-	-	-
		RESSEL (8-15)	-	-	-	-	-	-	-	-
		PORTSE L (0-7)	P0_20	P4_03	-	-	-	-	-	-
		PORTSE L (8-15)	-	-	-	-	-	-	-	-
RIC_RE SIN643 (0x0506)	I2S0_WS	RESSEL (0-7)	-	-	-	-	-	-	-	-
		RESSEL (8-15)	-	-	-	-	-	-	-	-
		PORTSE L (0-7)	P0_12	P3_26	-	-	-	-	-	-
		PORTSE L (8-15)	-	-	-	-	-	-	-	-
RIC_RE SIN644 (0x0508)	I2S0_SD	RESSEL (0-7)	-	-	-	-	-	-	-	-
		RESSEL (8-15)	-	-	-	-	-	-	-	-
		PORTSE L (0-7)	P0_11	P3_25	-	-	-	-	-	-
		PORTSE L (8-15)	-	-	-	-	-	-	-	-
RIC_RE SIN645 (0x050A)	I2S0_SCK	RESSEL (0-7)	-	-	-	-	-	-	-	-
		RESSEL (8-15)	-	-	-	-	-	-	-	-
		PORTSE L (0-7)	P0_13	P3_27	-	-	-	-	-	-
		PORTSE L (8-15)	-	-	-	-	-	-	-	-

Register (Offset)	Resource	RESSEL [3:0] /PORT SEL[3:0]	Source for Resource Input									
			0	1	2	3	4	5	6	7		
			8	9	10	11	12	13	14	15		
RIC_RE SIN646 (0x050C)	I2S0_ECLK	RESSEL (0-7)	PORT_ PIN	SYSC1_ CLK_ C D4	-	-	-	-	-	-	-	-
		RESSEL (8-15)	-	-	-	-	-	-	-	-	-	-
		PORTSE L (0-7)	P0_10	P3_24	-	-	-	-	-	-	-	-
		PORTSE L (8-15)	-	-	-	-	-	-	-	-	-	-
RIC_RE SIN650 (0x0514)	I2S1_ECLK	RESSEL (0-7)	PORT_ PIN	SYSC1_ CLK_ C D4	-	-	-	-	-	-	-	-
		RESSEL (8-15)	-	-	-	-	-	-	-	-	-	-
		PORTSE L (0-7)	-	-	-	-	-	-	-	-	-	-
		PORTSE L (8-15)	-	-	-	-	-	-	-	-	-	-
RIC_RE SIN685 (0x055A)	ADTRG0	RESSEL (0-7)	-	-	-	-	-	-	-	-	-	-
		RESSEL (8-15)	-	-	-	-	-	-	-	-	-	-
		PORTSE L (0-7)	P1_16	P2_10	-	-	-	-	-	-	-	-
		PORTSE L (8-15)	-	-	-	-	-	-	-	-	-	-
RIC_RE SIN686 (0x055C)	ADTRG1	RESSEL (0-7)	-	-	-	-	-	-	-	-	-	-
		RESSEL (8-15)	-	-	-	-	-	-	-	-	-	-
		PORTSE L (0-7)	P4_22	P1_08	P2_11	-	-	-	-	-	-	-
		PORTSE L (8-15)	-	-	-	-	-	-	-	-	-	-

**Notes:**

- When both GPIO\_PORTEN.GPORTEN and PPC\_PCFGR.PIE are configured as 0, the input signal is disconnected and external interrupt cannot be detected. During disconnecting, I/O internally outputs "low" to internal logic, and if ELVR is configured as low-level-detection, falling-edge-detection, or both-edge-detection it will be detected as external interrupt with EIRR = 1.
- "Set 0" (Set 1) means that "0" ("1") is inputted.
- OCUx\_MODn is described as MODn pin in Traveo™ Platform Hardware Manual.

## 7.2 Port Output Function Configuration

The port output function configuration (POF) is a function to select a function to output to a port.

A resource which supports a port output relocation has its PPC\_PCFGR.POF to configure resource output.

### 7.2.1 Standard Configuration (S6J3310)

Register (Offset)	Port	Resource Functional Outputs							
		POF = 0	POF = 1	POF = 2	POF = 3	POF = 4	POF = 5	POF = 6	POF = 7
PPC_PCF GR000 (0x0000)	P0_00	GPIO_PO DR0:POD 00	-	LCDD5	-	-	DSP0_R7_0	-	MAD1
PPC_PCF GR001 (0x0002)	P0_01	GPIO_PO DR0:POD 01	-	LCDD6	ARH0_AI C1_DNCLK	-	DSP0_G0_0	-	MAD2
PPC_PCF GR002 (0x0004)	P0_02	GPIO_PO DR0:POD 02	SCK1_0	LCDD7	ARH0_AI C1_TDA1	ARH0_AI C1_DND ATA1	DSP0_G1_0	SCL1	MAD3
PPC_PCF GR003 (0x0006)	P0_03	GPIO_PO DR0:POD 03	SOT1_0	LCDD8	ARH0_AI C1_dbg_out_1	-	DSP0_G2_0	SDA1	MAD4
PPC_PCF GR004 (0x0008)	P0_04	GPIO_PO DR0:POD 04	SCS10_0	LCDD9	ARH0_AI C1_dbg_out_0	-	DSP0_G3_0	-	MAD5
PPC_PCF GR005 (0x000A)	P0_05	GPIO_PO DR0:POD 05	SCS11_0	LCDD10	ARH0_AI C1_TDA0	ARH0_AI C1_DND ATA0	DSP0_G4_0	SOT0_1	MAD6
PPC_PCF GR006 (0x000C)	P0_06	GPIO_PO DR0:POD 06	SCS12_0	LCDD11	SCK0_1	-	DSP0_G5_0	PPG0_TO UT0_1	MAD7
PPC_PCF GR007 (0x000E)	P0_07	GPIO_PO DR0:POD 07	SCS13_0	LCDD12	SCS00_1	I2S1_SD_0	DSP0_G6_0	PPG0_TO UT2_1	MAD8
PPC_PCF GR008 (0x0010)	P0_08	GPIO_PO DR0:POD 08	-	LCDD13	-	I2S1_WS_0	DSP0_G7_0	PPG1_TO UT0_1	MAD9
PPC_PCF GR009 (0x0012)	P0_09	GPIO_PO DR0:POD 09	-	LCDD14	ARH0_AI C0_DNCLK	I2S1_SC K_0	DSP0_B0_0	PPG1_TO UT2_1	MAD10
PPC_PCF GR010 (0x0014)	P0_10	GPIO_PO DR0:POD 10	SCS171_1	LCDD15	ARH0_AI C0_TDA1	ARH0_AI C0_DND ATA1	DSP0_B1_0	PPG2_TO UT0_1	MAD11
PPC_PCF GR011 (0x0016)	P0_11	GPIO_PO DR0:POD 11	-	LCDD16	ARH0_AI C0_dbg_out_1	I2S0_SD_0	DSP0_B2_0	PPG2_TO UT2_1	MAD12
PPC_PCF GR012 (0x0018)	P0_12	GPIO_PO DR0:POD 12	-	LCDD17	ARH0_AI C0_dbg_out_0	I2S0_WS_0	DSP0_B3_0	PPG3_TO UT0_1	MAD13
PPC_PCF GR013 (0x001A)	P0_13	GPIO_PO DR0:POD 13	-	CS#	-	I2S0_SC K_0	DSP0_B4_0	PPG3_TO UT2_1	MAD14

Register (Offset)	Port	Resource Functional Outputs							
		POF = 0	POF = 1	POF = 2	POF = 3	POF = 4	POF = 5	POF = 6	POF = 7
PPC_PCF GR014 (0x001C)	P0_14	GPIO_PO DR0:POD 14	-	WR#	-	-	DSP0_B5_0	SCK4_1	MOEX
PPC_PCF GR015 (0x001E)	P0_15	GPIO_PO DR0:POD 15	-	RD#	-	-	DSP0_B6_0	SCS40_1	MWEX
PPC_PCF GR016 (0x0020)	P0_16	GPIO_PO DR0:POD 16	DSP0_B7_1	-	ARH0_AI CO_TDA0	ARH0_AI CO_DND ATA0	-	SCS41_1	MCLK
PPC_PCF GR017 (0x0022)	P0_17	GPIO_PO DR0:POD 17	-	-	-	-	DSP0_B7_0	SCS43_1	MDQM0
PPC_PCF GR018 (0x0024)	P0_18	GPIO_PO DR0:POD 18	-	RS	-	MDC_1	-	-	MCSX2
PPC_PCF GR019 (0x0026)	P0_19	GPIO_PO DR0:POD 19	-	RES#	-	-	-	-	MCSX3
PPC_PCF GR020 (0x0028)	P0_20	GPIO_PO DR0:POD 20	-	-	-	-	-	-	-
PPC_PCF GR021 (0x002A)	P0_21	GPIO_PO DR0:POD 21	-	M_SDATA 0_0	TXEN_0	M_DQ3	-	-	-
PPC_PCF GR022 (0x002C)	P0_22	GPIO_PO DR0:POD 22	SCK2_0	M_SDATA 0_2	TXD0_0	M_DQ2	SOT9_2	-	-
PPC_PCF GR023 (0x002E)	P0_23	GPIO_PO DR0:POD 23	SOT2_0	M_SDATA 0_1	TXD1_0	M_DQ1	SCK9_2	-	-
PPC_PCF GR024 (0x0030)	P0_24	GPIO_PO DR0:POD 24	SCS20_0	M_SSEL0	TXD2_0	M_DQ0	SCS90_2	-	-
PPC_PCF GR025 (0x0032)	P0_25	GPIO_PO DR0:POD 25	SCS21_0	M_SDATA 0_3	TXD3_0	M_CS#_1	SCS91_2	-	-
PPC_PCF GR026 (0x0034)	P0_26	GPIO_PO DR0:POD 26	SCS22_0	M_SCLK0	TXER_0	M_CK	-	-	-
PPC_PCF GR027 (0x0036)	P0_27	GPIO_PO DR0:POD 27	SCS23_0	M_SDATA 1_0	-	M_RWDS	-	-	-
PPC_PCF GR028 (0x0038)	P0_28	GPIO_PO DR0:POD 28	-	M_SDATA 1_2	-	M_DQ4	SCK8_2	-	-

Register (Offset)	Port	Resource Functional Outputs							
		POF = 0	POF = 1	POF = 2	POF = 3	POF = 4	POF = 5	POF = 6	POF = 7
PPC_PCF GR029 (0x003A)	P0_29	GPIO_PO DR0:POD 29	SCK3_0	M_SDATA 1_1	-	M_DQ5	SOT8_2	-	-
PPC_PCF GR030 (0x003C)	P0_30	GPIO_PO DR0:POD 30	SOT3_0	M_SSEL1	-	M_DQ6	SCS80_2	-	-
PPC_PCF GR031 (0x003E)	P0_31	GPIO_PO DR0:POD 31	SCS30_0	M_SDATA 1_3	MDIO_0	M_DQ7	-	-	-
PPC_PCF GR100 (0x0040)	P1_00	GPIO_PO DR1:POD 00	SCS31_0	-	MDC_0	M_CS#_2	-	-	-
PPC_PCF GR101 (0x0042)	P1_01	GPIO_PO DR1:POD 01	SCS32_0	-	-	-	-	-	MLBSIG
PPC_PCF GR102 (0x0044)	P1_02	GPIO_PO DR1:POD 02	SCS33_0	-	-	-	-	-	MLBDAT
PPC_PCF GR103 (0x0046)	P1_03	GPIO_PO DR1:POD 03	-	-	-	OCU0_O TD0_0	-	PPG0_TO UT0_0	BN0(BL0)
PPC_PCF GR104 (0x0048)	P1_04	GPIO_PO DR1:POD 04	SCK0_0	-	SCL0	OCU0_O TD1_0	TOT0_0	PPG0_TO UT2_0	BP0(BH0)
PPC_PCF GR105 (0x004A)	P1_05	GPIO_PO DR1:POD 05	SOT0_0	SGA0_0	SDA0	TRACE0_0	-	PPG1_TO UT0_0	AN0(AL0)
PPC_PCF GR106 (0x004C)	P1_06	GPIO_PO DR1:POD 06	SCS00_0	SGO0_0	TX0_0	TRACE1_0	TOT1_0	PPG1_TO UT2_0	AP0(AH0)
PPC_PCF GR107 (0x004E)	P1_07	GPIO_PO DR1:POD 07	-	SGA1_0	TRACE2_0	OCU1_O TD0_0	-	PPG2_TO UT0_0	BN1(BL1)
PPC_PCF GR108 (0x0050)	P1_08	GPIO_PO DR1:POD 08	TRACE3_0	SGO1_0	TX1_0	OCU1_O TD1_0	TOT16_0	PPG2_TO UT2_0	BP1(BH1)
PPC_PCF GR109 (0x0052)	P1_09	GPIO_PO DR1:POD 09	SCK16_0	SGA2_0	SCL16	OCU2_O TD0_0	TRACE_CTL_0	PPG3_TO UT0_0	AN1(AL1)
PPC_PCF GR110 (0x0054)	P1_10	GPIO_PO DR1:POD 10	SOT16_0	SGO2_0	SDA16	OCU2_O TD1_0	TRACE_CLK_0	PPG3_TO UT2_0	AP1(AH1)
PPC_PCF GR111 (0x0056)	P1_11	GPIO_PO DR1:POD 11	SCS160_0	INDICAT OR0_0	-	OCU8_O TD0_0	-	PPG4_TO UT0_0	-

Register (Offset)	Port	Resource Functional Outputs							
		POF = 0	POF = 1	POF = 2	POF = 3	POF = 4	POF = 5	POF = 6	POF = 7
PPC_PCF GR112 (0x0058)	P1_12	GPIO_PO DR1:POD 12	SCS161_0	-	-	OCU8_O TD1_0	TOT17_0	PPG4_TO UT2_0	TX2_0
PPC_PCF GR113 (0x005A)	P1_13	GPIO_PO DR1:POD 13	-	SGA3_0	-	OCU9_O TD0_0	-	-	-
PPC_PCF GR114 (0x005C)	P1_14	GPIO_PO DR1:POD 14	SYSC0_C LK_1	SGO3_0	-	OCU9_O TD1_0	TOT48_0	PPG5_TO UT0_0	TX3_0
PPC_PCF GR115 (0x005E)	P1_15	GPIO_PO DR1:POD 15	SCK17_0	SGA4_0	SCL17	OCU10_ OTD0_0	SCK12_1	PPG5_TO UT2_0	INDICAT OR0_1
PPC_PCF GR116 (0x0060)	P1_16	GPIO_PO DR1:POD 16	SOT17_0	SGO4_0	SDA17	OCU10_ OTD1_0	TOT49_0	SYSC0_C LK_0	WOT
PPC_PCF GR117 (0x0062)	P1_17	GPIO_PO DR1:POD 17	SCS170_0	-	-	-	PWM1P0	PPG6_TO UT0_0	-
PPC_PCF GR118 (0x0064)	P1_18	GPIO_PO DR1:POD 18	SCS171_0	-	-	-	PWM1M0	PPG6_TO UT2_0	TX5_0
PPC_PCF GR119 (0x0066)	P1_19	GPIO_PO DR1:POD 19	-	-	-	-	PWM2P0	PPG7_TO UT0_0	-
PPC_PCF GR120 (0x0068)	P1_20	GPIO_PO DR1:POD 20	SCK8_0	-	SCL8	-	PWM2M0	PPG7_TO UT2_0	-
PPC_PCF GR121 (0x006A)	P1_21	GPIO_PO DR1:POD 21	SOT8_0	-	SDA8	-	PWM1P1	PPG8_TO UT0_0	-
PPC_PCF GR122 (0x006C)	P1_22	GPIO_PO DR1:POD 22	SCS80_0	-	-	-	PWM1M1	PPG8_TO UT2_0	TX6_0
PPC_PCF GR123 (0x006E)	P1_23	GPIO_PO DR1:POD 23	-	-	-	-	PWM2P1	PPG9_TO UT0_0	-
PPC_PCF GR124 (0x0070)	P1_24	GPIO_PO DR1:POD 24	SCK9_0	-	SCL9	-	PWM2M1	PPG9_TO UT2_0	-
PPC_PCF GR125 (0x0072)	P1_25	GPIO_PO DR1:POD 25	SOT9_0	-	SDA9	-	PWM1P2	PPG10_T OUT0_0	-
PPC_PCF GR126 (0x0074)	P1_26	GPIO_PO DR1:POD 26	SCS90_0	-	-	-	PWM1M2	PPG10_T OUT2_0	-

Register (Offset)	Port	Resource Functional Outputs							
		POF = 0	POF = 1	POF = 2	POF = 3	POF = 4	POF = 5	POF = 6	POF = 7
PPC_PCF GR127 (0x0076)	P1_27	GPIO_PO DR1:POD 27	SCS91_0	-	-	-	PWM2P2	PPG11_T OUT0_0	-
PPC_PCF GR128 (0x0078)	P1_28	GPIO_PO DR1:POD 28	-	-	-	-	PWM2M2	PPG11_T OUT2_0	-
PPC_PCF GR129 (0x007A)	P1_29	GPIO_PO DR1:POD 29	SCK10_0	-	SCL10	-	PWM1P3	-	-
PPC_PCF GR130 (0x007C)	P1_30	GPIO_PO DR1:POD 30	SOT10_0	-	SDA10	-	PWM1M3	PPG12_T OUT0_0	-
PPC_PCF GR131 (0x007E)	P1_31	GPIO_PO DR1:POD 31	SCS100_0	-	-	-	PWM2P3	PPG12_T OUT2_0	-
PPC_PCF GR200 (0x0080)	P2_00	GPIO_PO DR2:POD 00	-	-	-	-	PWM2M3	PPG13_T OUT0_0	-
PPC_PCF GR201 (0x0082)	P2_01	GPIO_PO DR2:POD 01	SCK11_0	-	SCL11	-	PWM1P4	PPG13_T OUT2_0	-
PPC_PCF GR202 (0x0084)	P2_02	GPIO_PO DR2:POD 02	SOT11_0	-	SDA11	-	PWM1M4	PPG14_T OUT0_0	-
PPC_PCF GR203 (0x0086)	P2_03	GPIO_PO DR2:POD 03	SCS110_0	-	-	-	PWM2P4	PPG14_T OUT2_0	-
PPC_PCF GR204 (0x0088)	P2_04	GPIO_PO DR2:POD 04	SCS111_0	-	-	-	PWM2M4	PPG15_T OUT0_0	-
PPC_PCF GR205 (0x008A)	P2_05	GPIO_PO DR2:POD 05	-	-	-	-	PWM1P5	PPG15_T OUT2_0	-
PPC_PCF GR206 (0x008C)	P2_06	GPIO_PO DR2:POD 06	SCK12_0	-	SCL12	-	PWM1M5	-	-
PPC_PCF GR207 (0x008E)	P2_07	GPIO_PO DR2:POD 07	SOT12_0	-	SDA12	-	PWM2P5	-	-
PPC_PCF GR208 (0x0090)	P2_08	GPIO_PO DR2:POD 08	SCS120_0	-	-	-	PWM2M5	-	-
PPC_PCF GR209 (0x0092)	P2_09	GPIO_PO DR2:POD 09	SCS23_1	-	-	-	DSP0_EN_0	PPG14_T OUT0_1	MCSX0



Register (Offset)	Port	Resource Functional Outputs							
		POF = 0	POF = 1	POF = 2	POF = 3	POF = 4	POF = 5	POF = 6	POF = 7
PPC_PCF GR210 (0x0094)	P2_10	GPIO_PO DR2:POD 10	SCS31_1	-	-	-	DSP0_HS YNC_0	-	MCSX1
PPC_PCF GR211 (0x0096)	P2_11	GPIO_PO DR2:POD 11	SCS32_1	-	-	-	DSP0_VS YNC_0	-	MDATA0
PPC_PCF GR212 (0x0098)	P2_12	GPIO_PO DR2:POD 12	SCS33_1	-	-	-	DSP0_CL K_0	-	MDATA1
PPC_PCF GR213 (0x009A)	P2_13	GPIO_PO DR2:POD 13	-	-	-	-	DSP0_R0 _0	-	MDATA2
PPC_PCF GR214 (0x009C)	P2_14	GPIO_PO DR2:POD 14	SCK4_0	-	SCL4	-	DSP0_R1 _0	-	MDATA3
PPC_PCF GR215 (0x009E)	P2_15	GPIO_PO DR2:POD 15	SOT4_0	LCDD0	SDA4	-	DSP0_R2 _0	-	MDATA4
PPC_PCF GR216 (0x00A0)	P2_16	GPIO_PO DR2:POD 16	SCS40_0	LCDD1	-	-	DSP0_R3 _0	-	MDATA5
PPC_PCF GR217 (0x00A2)	P2_17	GPIO_PO DR2:POD 17	SCS41_0	LCDD2	-	-	DSP0_R4 _0	-	MDATA6
PPC_PCF GR218 (0x00A4)	P2_18	GPIO_PO DR2:POD 18	SCS42_0	LCDD3	-	-	DSP0_R5 _0	-	MDATA7
PPC_PCF GR219 (0x00A6)	P2_19	GPIO_PO DR2:POD 19	SCS43_0	LCDD4	-	-	DSP0_R6 _0	-	MAD0
PPC_PCF GR300 (0x00C0)	P3_00	GPIO_PO DR3:POD 00	-	TXD1_1	-	-	-	PPG4_TO UT0_1	MAD15
PPC_PCF GR301 (0x00C2)	P3_01	GPIO_PO DR3:POD 01	SCK1_1	TXD2_1	-	-	-	PPG4_TO UT2_1	MAD16
PPC_PCF GR302 (0x00C4)	P3_02	GPIO_PO DR3:POD 02	SOT1_1	TXD3_1	-	-	-	PPG5_TO UT0_1	MAD17
PPC_PCF GR303 (0x00C6)	P3_03	GPIO_PO DR3:POD 03	SCS10_1	TXER_1	-	-	-	PPG5_TO UT2_1	MAD18
PPC_PCF GR304 (0x00C8)	P3_04	GPIO_PO DR3:POD 04	SCS11_1	-	-	-	-	-	MAD19

Register (Offset)	Port	Resource Functional Outputs							
		POF = 0	POF = 1	POF = 2	POF = 3	POF = 4	POF = 5	POF = 6	POF = 7
PPC_PCF GR305 (0x00CA)	P3_05	GPIO_PO DR3:POD 05	SCS12_1	-	-	-	-	-	MAD20
PPC_PCF GR306 (0x00CC)	P3_06	GPIO_PO DR3:POD 06	SCS13_1	MDIO_1	-	-	-	SOT4_1	MAD21
PPC_PCF GR307 (0x00CE)	P3_07	GPIO_PO DR3:POD 07	-	-	-	-	-	SCS42_1	MDQM1
PPC_PCF GR308 (0x00D0)	P3_08	GPIO_PO DR3:POD 08	-	SGA0_1	PPG6_TO UT0_1	OCU0_O TD0_1	-	-	-
PPC_PCF GR309 (0x00D2)	P3_09	GPIO_PO DR3:POD 09	SCK8_1	SGO0_1	PPG6_TO UT2_1	OCU0_O TD1_1	TOT0_1	-	-
PPC_PCF GR310 (0x00D4)	P3_10	GPIO_PO DR3:POD 10	SOT8_1	SGA1_1	PPG7_TO UT0_1	OCU1_O TD0_1	TRACE0_1	-	TX0_1
PPC_PCF GR311 (0x00D6)	P3_11	GPIO_PO DR3:POD 11	SCS80_1	SGO1_1	PPG7_TO UT2_1	OCU1_O TD1_1	TOT1_1	TRACE1_1	-
PPC_PCF GR312 (0x00D8)	P3_12	GPIO_PO DR3:POD 12	-	SGA2_1	PPG8_TO UT0_1	OCU2_O TD0_1	-	TRACE2_1	TX1_1
PPC_PCF GR313 (0x00DA)	P3_13	GPIO_PO DR3:POD 13	SCK10_1	SGO2_1	PPG8_TO UT2_1	OCU2_O TD1_1	TOT16_1	TRACE3_1	-
PPC_PCF GR314 (0x00DC)	P3_14	GPIO_PO DR3:POD 14	SOT10_1	SGA3_1	PPG9_TO UT0_1	OCU8_O TD0_1	-	TRACE_CTL_1	-
PPC_PCF GR315 (0x00DE)	P3_15	GPIO_PO DR3:POD 15	SCS100_1	SGO3_1	PPG9_TO UT2_1	OCU8_O TD1_1	TOT17_1	TRACE_CLK_1	TX2_1
PPC_PCF GR316 (0x00E0)	P3_16	GPIO_PO DR3:POD 16	-	SGA4_1	PPG10_T OUT0_1	OCU9_O TD0_1	-	-	-
PPC_PCF GR317 (0x00E2)	P3_17	GPIO_PO DR3:POD 17	-	SGO4_1	PPG10_T OUT2_1	OCU9_O TD1_1	TOT48_1	-	TX3_1
PPC_PCF GR318 (0x00E4)	P3_18	GPIO_PO DR3:POD 18	-	-	PPG11_T OUT0_1	OCU10_OTD0_1	-	-	-
PPC_PCF GR319 (0x00E6)	P3_19	GPIO_PO DR3:POD 19	SCK9_1	-	PPG11_T OUT2_1	OCU10_OTD1_1	-	-	-

Register (Offset)	Port	Resource Functional Outputs							
		POF = 0	POF = 1	POF = 2	POF = 3	POF = 4	POF = 5	POF = 6	POF = 7
PPC_PCF GR320 (0x00E8)	P3_20	GPIO_PO DR3:POD 20	SOT9_1	-	-	-	-	-	TX5_1
PPC_PCF GR321 (0x00EA)	P3_21	GPIO_PO DR3:POD 21	SCS90_1	-	-	-	TOT49_1	-	-
PPC_PCF GR322 (0x00EC)	P3_22	GPIO_PO DR3:POD 22	SCS91_1	-	-	-	-	-	-
PPC_PCF GR323 (0x00EE)	P3_23	GPIO_PO DR3:POD 23	-	-	-	-	SCS120_1	-	TX6_1
PPC_PCF GR324 (0x00F0)	P3_24	GPIO_PO DR3:POD 24	SOT2_1	-	-	-	-	PPG12_T OUT0_1	MDATA8
PPC_PCF GR325 (0x00F2)	P3_25	GPIO_PO DR3:POD 25	SCS20_1	-	-	-	I2S0_SD_1	PPG12_T OUT2_1	MDATA9
PPC_PCF GR326 (0x00F4)	P3_26	GPIO_PO DR3:POD 26	SCS21_1	-	-	-	I2S0_WS_1	PPG13_T OUT0_1	MDATA10
PPC_PCF GR327 (0x00F6)	P3_27	GPIO_PO DR3:POD 27	SCS22_1	-	-	-	I2S0_SC K_1	PPG13_T OUT2_1	MDATA11
PPC_PCF GR328 (0x00F8)	P3_28	GPIO_PO DR3:POD 28	-	-	-	-	-	PPG14_T OUT2_1	MDATA12
PPC_PCF GR329 (0x00FA)	P3_29	GPIO_PO DR3:POD 29	SCK3_1	-	-	-	-	PPG15_T OUT0_1	MDATA13
PPC_PCF GR330 (0x00FC)	P3_30	GPIO_PO DR3:POD 30	SOT3_1	-	-	-	-	PPG15_T OUT2_1	MDATA14
PPC_PCF GR331 (0x00FE)	P3_31	GPIO_PO DR3:POD 31	SCS30_1	-	-	-	-	-	MDATA15
PPC_PCF GR400 (0x0100)	P4_00	GPIO_PO DR4:POD 00	-	-	-	-	-	-	-
PPC_PCF GR401 (0x0102)	P4_01	GPIO_PO DR4:POD 01	-	-	-	-	TX0_2	-	-
PPC_PCF GR402 (0x0104)	P4_02	GPIO_PO DR4:POD 02	-	-	-	-	-	-	-

Register (Offset)	Port	Resource Functional Outputs							
		POF = 0	POF = 1	POF = 2	POF = 3	POF = 4	POF = 5	POF = 6	POF = 7
PPC_PCF GR403 (0x0106)	P4_03	GPIO_PO DR4:POD 03	-	-	SCS170_1	-	-	-	-
PPC_PCF GR404 (0x0108)	P4_04	GPIO_PO DR4:POD 04	-	TXEN_1	SCK17_1	-	TX3_2	-	-
PPC_PCF GR405 (0x010A)	P4_05	GPIO_PO DR4:POD 05	-	TXD0_1	SOT17_1	-	-	-	-
PPC_PCF GR406 (0x010C)	P4_06	GPIO_PO DR4:POD 06	-	-	-	-	-	-	-
PPC_PCF GR407 (0x010E)	P4_07	GPIO_PO DR4:POD 07	-	-	-	-	-	-	-
PPC_PCF GR408 (0x0110)	P4_08	GPIO_PO DR4:POD 08	-	-	-	-	-	-	-
PPC_PCF GR409 (0x0112)	P4_09	GPIO_PO DR4:POD 09	-	-	-	-	-	-	-
PPC_PCF GR410 (0x0114)	P4_10	GPIO_PO DR4:POD 10	-	-	-	-	-	-	-
PPC_PCF GR411 (0x0116)	P4_11	GPIO_PO DR4:POD 11	-	-	-	-	-	-	-
PPC_PCF GR412 (0x0118)	P4_12	GPIO_PO DR4:POD 12	-	-	-	-	-	-	-
PPC_PCF GR413 (0x011A)	P4_13	GPIO_PO DR4:POD 13	-	-	-	-	-	-	-
PPC_PCF GR414 (0x011C)	P4_14	GPIO_PO DR4:POD 14	-	-	-	-	-	-	-
PPC_PCF GR415 (0x011E)	P4_15	GPIO_PO DR4:POD 15	-	-	-	-	-	-	-
PPC_PCF GR416 (0x0120)	P4_16	GPIO_PO DR4:POD 16	-	-	-	-	-	-	-
PPC_PCF GR417 (0x0122)	P4_17	GPIO_PO DR4:POD 17	-	-	-	-	SOT12_1	-	-

Register (Offset)	Port	Resource Functional Outputs							
		POF = 0	POF = 1	POF = 2	POF = 3	POF = 4	POF = 5	POF = 6	POF = 7
PPC_PCF GR418 (0x0124)	P4_18	GPIO_PO DR4:POD 18	-	-	-	-	-	-	-
PPC_PCF GR419 (0x0126)	P4_19	GPIO_PO DR4:POD 19	-	-	-	-	-	-	-
PPC_PCF GR420 (0x0128)	P4_20	GPIO_PO DR4:POD 20	-	-	-	-	SOT16_1	-	-
PPC_PCF GR421 (0x012A)	P4_21	GPIO_PO DR4:POD 21	-	-	-	-	SCK16_1	-	-
PPC_PCF GR422 (0x012C)	P4_22	GPIO_PO DR4:POD 22	-	-	-	-	SCS161_1	-	-
PPC_PCF GR423 (0x012E)	P4_23	GPIO_PO DR4:POD 23	-	-	-	-	SCS160_1	-	-
PPC_PCF GR424 (0x0130)	P4_24	GPIO_PO DR4:POD 24	-	-	-	-	-	-	-
PPC_PCF GR425 (0x0132)	P4_25	GPIO_PO DR4:POD 25	-	-	-	-	-	-	-
PPC_PCF GR426 (0x0134)	P4_26	GPIO_PO DR4:POD 26	-	-	-	-	-	-	-
PPC_PCF GR427 (0x0136)	P4_27	GPIO_PO DR4:POD 27	-	-	-	-	-	-	-
PPC_PCF GR428 (0x0138)	P4_28	GPIO_PO DR4:POD 28	-	-	-	-	-	-	-
PPC_PCF GR429 (0x013A)	P4_29	GPIO_PO DR4:POD 29	-	-	-	-	-	-	-
PPC_PCF GR430 (0x013C)	P4_30	GPIO_PO DR4:POD 30	-	-	-	-	-	-	-
PPC_PCF GR431 (0x013E)	P4_31	GPIO_PO DR4:POD 31	SCK2_1	-	-	-	-	-	-

**Notes:**

- The hyphen indicates that setting is prohibited. If setting the port will be operated as input independent on the register value of the GPIO\_DDR.
- The register for P0\_20 for POF exists though the port only supports input not supports output. The configuration of POF = 0 for the port does not affect anything.

## 8. Precautions and Handling Devices

### 8.1 Handling Precautions

Any semiconductor devices have inherently a certain rate of failure. The possibility of failure is greatly affected by the conditions in which they are used (circuit conditions, environmental conditions, etc.). This page describes precautions that must be observed to minimize the chance of failure and to obtain higher reliability from your Cypress semiconductor devices.

#### 8.1.1 Precautions for Product Design

This section describes precautions when designing electronic equipment using semiconductor devices.

#### Absolute Maximum Ratings

Semiconductor devices can be permanently damaged by application of stress (voltage, current, temperature, and so on.) in excess of certain established limits, called absolute maximum ratings. Do not exceed these ratings.

#### Recommended Operating Conditions

Recommended operating conditions are normal operating ranges for the semiconductor device. All the device's electrical characteristics are warranted when operated within these ranges.

Always use semiconductor devices within the recommended operating conditions. Operation outside these ranges may adversely affect reliability and could result in device failure.

No warranty is made with respect to uses, operating conditions, or combinations not represented on the data sheet. Users considering application outside the listed conditions are advised to contact their sales representative beforehand.

#### Processing and Protection of Pins

These precautions must be followed when handling the pins which connect semiconductor devices to power supply and input/output functions.

##### (1) Preventing Over-Voltage and Over-Current Conditions

Exposure to voltage or current levels in excess of maximum ratings at any pin is likely to cause deterioration within the device and in extreme cases leads to permanent damage of the device. Try to prevent such overvoltage or over-current conditions at the design stage.

##### (2) Protection of Output Pins

Shorting of output pins to supply pins or other output pins, or connection to large capacitance can cause large current flows. Such conditions if present for extended periods of time can damage the device.

Therefore, avoid this type of connection.

##### (3) Handling of Unused Input Pins

Unconnected input pins with very high impedance levels can adversely affect stability of operation. Such pins should be connected through an appropriate resistance to a power supply pin or ground pin.

### 8.1.2 Precautions for Package Mounting

Package mounting may be either lead insertion type or surface mount type. In either case, for heat resistance during soldering, you should only mount under Cypress's recommended conditions. For detailed information about mount conditions, contact your sales representative.

#### Lead Insertion Type

Mounting of lead insertion type packages onto printed circuit boards may be done by two methods: direct soldering on the board, or mounting by using a socket.

Direct mounting onto boards normally involves processes for inserting leads into through-holes on the board and using the flow soldering (wave soldering) method of applying liquid solder. In this case, the soldering process usually causes leads to be subjected to thermal stress in excess of the absolute ratings for storage temperature. Mounting processes should conform to Cypress recommended mounting conditions.

If socket mounting is used, differences in surface treatment of the socket contacts and IC lead surfaces can lead to contact deterioration after long periods. For this reason it is recommended that the surface treatment of socket contacts and IC leads be verified before mounting.

#### Surface Mount Type

Surface mount packaging has longer and thinner leads than lead-insertion packaging, and therefore leads are more easily deformed or bent. The use of packages with higher pin counts and narrower pin pitch results in increased susceptibility to open connections caused by deformed pins, or shorting due to solder bridges.

You must use appropriate mounting techniques. Cypress recommends the solder reflow method, and has established a ranking of mounting conditions for each product. Users are advised to mount packages in accordance with Cypress ranking of recommended conditions.

#### Lead-Free Packaging

**CAUTION:** When ball grid array (BGA) packages with Sn-Ag-Cu balls are mounted using Sn-Pb eutectic soldering, junction strength may be reduced under some conditions of use.

#### Storage of Semiconductor Devices

Because plastic chip packages are formed from plastic resins, exposure to natural environmental conditions will cause absorption of moisture. During mounting, the application of heat to a package that has absorbed moisture can cause surfaces to peel, reducing moisture resistance and causing packages to crack. To prevent, do the following:

- (1) Avoid exposure to rapid temperature changes, which cause moisture to condense inside the product. Store products in locations where temperature changes are slight.
- (2) Use dry boxes for product storage. Products should be stored below 70 % relative humidity, and at temperatures between 5 °C and 30 °C. When you open Dry Package that recommends humidity 40 % to 70 % relative humidity.
- (3) When necessary, Cypress packages semiconductor devices in highly moisture-resistant aluminum laminate bags, with a silica gel desiccant. Devices should be sealed in their aluminum laminate bags for storage.
- (4) Avoid storing packages where they are exposed to corrosive gases or high levels of dust.

#### Baking

Packages that have absorbed moisture may be de-moisturized by baking (heat drying). Follow the Cypress recommended conditions for baking.

Condition: 125 °C/24 h

#### Static Electricity

Because semiconductor devices are particularly susceptible to damage by static electricity, you must take the following precautions:

- (1) Maintain relative humidity in the working environment between 40 % and 70 %. Use of an apparatus for ion generation may be needed to remove electricity.
- (2) Electrically ground all conveyors, solder vessels, soldering irons and peripheral equipment.
- (3) Eliminate static body electricity by the use of rings or bracelets connected to ground through high resistance (on the level of 1 MΩ). Wearing of conductive clothing and shoes, use of conductive floor mats and other measures to minimize shock loads is recommended.
- (4) Ground all fixtures and instruments, or protect with anti-static measures.

(5) Avoid the use of styrofoam or other highly static-prone materials for storage of completed board assemblies.

### **8.1.3 Precautions for Use Environment**

Reliability of semiconductor devices depends on ambient temperature and other conditions as described above.

For reliable performance, do the following:

#### (1) Humidity

Prolonged use in high humidity can lead to leakage in devices as well as printed circuit boards. If high humidity levels are anticipated, consider anti-humidity processing.

#### (2) Discharge of Static Electricity

When high-voltage charges exist close to semiconductor devices, discharges can cause abnormal operation. In such cases, use anti-static measures or processing to prevent discharges.

#### (3) Corrosive Gases, Dust, or Oil

Exposure to corrosive gases or contact with dust or oil may lead to chemical reactions that will adversely affect the device. If you use devices in such conditions, consider ways to prevent such exposure or to protect the devices.

#### (4) Radiation, Including Cosmic Radiation

Most devices are not designed for environments involving exposure to radiation or cosmic radiation. Users should provide shielding as appropriate.

#### (5) Smoke, Flame

**CAUTION:** Plastic molded devices are flammable, and therefore should not be used near combustible substances. If devices begin to smoke or burn, there is danger of the release of toxic gases.

Customers considering the use of Cypress products in other special environmental conditions should consult with sales representatives.



## 8.2 Handling Devices

### For Latch-Up Prevention

The latch-up phenomenon may occur on a CMOS IC in the following cases: the voltage applied to an input or output pin is higher than VCC or lower than VSS; or the voltage applied between a VCC pin and a VSS pin exceeds the rating. A latch-up causes a rapid increase in the power supply current, possibly resulting in thermal damage to an element. When using the device, take sufficient care not to exceed the maximum rating.

Also be careful that analog power supplies (AVCC5,AVRH5) and analog inputs do not exceed the digital power supply (VCC) at the analog system power-on and power-off times.

The power-on sequence is as follows. Simultaneously turn on the digital supply voltage (VCC) and analog supply voltages (AVCC5,AVRH5), or turn on the digital supply voltage (VCC) and then the analog supply voltages (AVCC5,AVRH5).

### About Handling Unused Pins

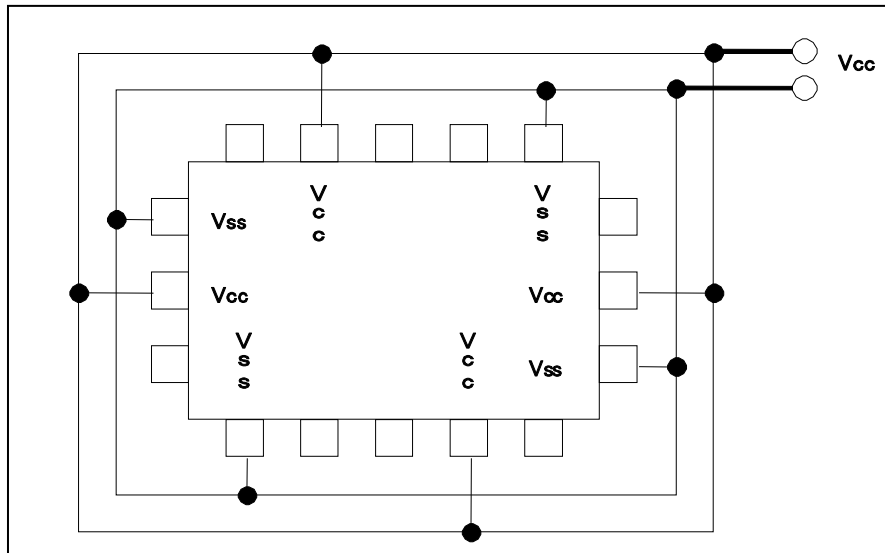
Leaving unused input pins open may cause permanent damage from a malfunction or latch-up. Take measures for unused pins, such as pulling up or pulling down the voltage with resistors of 2 kilo ohms or higher.

If there are any unused input/output pins, set them to the output state and then open them, or set them to the input state and handle them in the same way as input pins.

### About Power Supply Pins

If the device has multiple VCC and VSS pins, the device is designed in such a way that the pins that should be at the same potential are connected to each other inside the device to prevent malfunctions such as latch-up. However, to reduce unwanted emissions, prevent malfunctions of strobe signals caused by an increase of the ground level, and observe standards on total output current, be sure to connect all the VCC and VSS pins to the power source and ground externally. Also handle all the VSS power supply pins in this way as shown in the following diagram. If there are multiple VCC or VSS systems, the device does not operate normally even within the guaranteed operating range.

**Figure 8-1 Pin Assignment**



In addition, consider connecting with low impedance from the power supply source to the VCC and VSS of this device. We recommend connecting a ceramic capacitor as a bypass capacitor between VCC and VSS, near this device.

### About the Crystal Oscillation Circuit

Noise entering the X0 or X1 pin may cause a malfunction. Design the printed circuit board in such a way that the X0 and X1 pins, the crystal oscillator (or ceramic resonator), and a bypass capacitor to ground are located very close to the device.

We recommend that the printed circuit board artwork have the X0 and X1 pins enclosed by ground.

### About the Mode Pin (MODE)

Use mode pin MODE by directly connecting it to a VCC or VSS pin. To prevent noise from causing the device to accidentally enter test mode, reduce the pattern length between each mode pin and a VCC or VSS pin on the printed circuit board, and connect them with low impedance.

### About the Power-on Time

To prevent the internal built-in voltage step-down circuit from malfunctioning, secure a voltage rising time of 50  $\mu$ s (between 0.2 V and 2.7 V) or longer at the power-on time.

### Point to Note during PLL Clock Operation

While a PLL clock is selected, if the oscillator breaks off or input stops, the PLL clock may continue operating with the free running frequency of the internal self-oscillator circuit. This operation is outside of the guaranteed range.

### Power Supply Pin Processing of an A/D Converter

Even when no A/D converter is used, establish a connection such that AVCC5 = AVRH5 = VCC5 and AVSS/AVRL5 = VSS.

### Points to Note About Using External Clocks

External clocks are not supported.

External direct clock input cannot be used.

### Power-on Sequence of the Power Supply Analog Inputs of an A/D Converter

Be sure to turn on the digital power supply (VCC) before the application of the power supplies (AVCC, AVRH, and AVRL) and analog inputs (AN0 to AN63) of an A/D converter.

At the power-off time, turn off the power supplies and analog inputs of the A/D converter, and then turn off the digital power supply (VCC). Perform these power-on and power-off operations without AVRH exceeding AVCC. Even when using a pin shared with an analog input as an input port, do not allow the input voltage to exceed AVCC. (Turning on or off the analog supply voltage and digital supply voltage simultaneously is not a problem.)

### Method to Switch Off VCC12 during Power-Off Sequence

During power-off sequence, it is necessary to switch off VCC12 by driving PSC1 pin low by entering PSS mode (power domain 2 off). If VCC12 needs to be switched off by other means, RSTX needs to be asserted before switching off VCC12 to inactivate the operation of VCC12 supplied domain below the operation assurance range.

### About C Pin Processing

This device has a built-in voltage step-down circuit. Be sure to connect a capacitor to the C pin for internal stabilization of the device. For the standard values, see "Recommended operating conditions" in the latest data sheet.

### Precautions on Designing a Mounting Substrate

Measures against heat generation from the package must be taken for the mounting substrate to observe the absolute maximum rating (operating temperature). Design a mounting substrate with 4 or more layers. Connect the back of the package stage and the substrate pad with solder paste. Arrange thermal via holes on the substrate pad.

### Notes on Writing to a Register Containing a Status Flag

In writing to a register containing a status flag (particularly an interrupt request flag, etc.) to control a function, it is important to take care not to accidentally clear the status flag.

Therefore, before the write operation, configure the status bit such that the flag is not cleared, and then set the control bit to the desired value.

Especially for control bits configured as a set of multiple bits, bit instructions cannot be used (bit instructions have only 1-bit access). In such cases, byte, half-word, or word access is used to write to the control bits and a status flag simultaneously. However, at this time, be careful not to accidentally clear bits other than the intended ones (the status flag bit in this case).

Note: Bit instructions take this point into account for registers that support bit-band units, so it does not need to be a concern. You need to take care when using bit instructions for registers that do not support bit-band units.

## 9. Electric Characteristics

### 9.1 Electrical Characteristics

This chapter contains target values and information.

Target values and information are subjects to change without notice.

#### 9.1.1 Absolute Maximum Rating

Parameter	Symbol	Rating		Unit	Remarks
		Min	Max		
Power supply voltage <sup>*1, *2</sup>	V <sub>CC5</sub>	V <sub>SS</sub> -0.3	V <sub>SS</sub> +6.0	V	
	V <sub>CC53</sub>	V <sub>SS</sub> -0.3	V <sub>SS</sub> +6.0	V	V <sub>CC53</sub> ≤ V <sub>CC5</sub>
	V <sub>CC3</sub>	V <sub>SS</sub> -0.3	V <sub>SS</sub> +4.0	V	V <sub>CC3</sub> ≤ V <sub>CC5</sub>
	DV <sub>CC</sub>	V <sub>SS</sub> -0.3	V <sub>SS</sub> +6.0	V	
	V <sub>CC12</sub>	V <sub>SS</sub> -0.3	V <sub>SS</sub> +1.8	V	V <sub>CC12</sub> ≤ AV <sub>CC5</sub>
Analog supply voltage <sup>*1, *2</sup>	AV <sub>CC5</sub>	V <sub>SS</sub> -0.3	V <sub>SS</sub> +6.0	V	AV <sub>CC5</sub> ≤ V <sub>CC5</sub>
	AV <sub>CC3_DAC</sub>	V <sub>SS</sub> -0.3	V <sub>SS</sub> +4.0	V	for DAC
Analog reference voltage <sup>*1</sup>	AVRH	V <sub>SS</sub> -0.3	V <sub>SS</sub> +6.0	V	AVRH ≤ AV <sub>CC5</sub>
Input voltage <sup>*1</sup>	V <sub>I1</sub>	V <sub>SS</sub> -0.3	V <sub>CC5</sub> +0.3	V	5 V pins not shared SMC
	V <sub>I2</sub>	V <sub>SS</sub> -0.3	DV <sub>CC</sub> +0.3	V	5 V pins shared SMC
	V <sub>I3</sub>	V <sub>SS</sub> -0.3	V <sub>CC3</sub> +0.3	V	3 V pins
	V <sub>IE</sub>	V <sub>SS</sub> -0.3	V <sub>CC53</sub> +0.3	V	5 V/3 V pins
Analog pin input voltage <sup>*1</sup>	V <sub>IA</sub>	V <sub>SS</sub> -0.3	V <sub>CC5</sub> +0.3	V	
Output voltage <sup>*1</sup>	V <sub>O1</sub>	V <sub>SS</sub> -0.3	V <sub>CC5</sub> +0.3	V	5 V pins not shared SMC
	V <sub>O2</sub>	V <sub>SS</sub> -0.3	DV <sub>CC</sub> +0.3	V	5 V pins shared SMC
	V <sub>O3</sub>	V <sub>SS</sub> -0.3	V <sub>CC3</sub> +0.3	V	3 V pins
	V <sub>O4</sub>	V <sub>SS</sub> -0.3	V <sub>CC53</sub> +0.3	V	5 V/3 V pins
Maximum clamp current	I <sub>CLAMP</sub>	-	4	mA	<sup>*13, *A</sup>
Total maximum clamp current	Σ I <sub>CLAMP</sub>	-	20	mA	<sup>*13, *A</sup>
Total maximum clamp current	Σ I <sub>CLAMP</sub>	-	90	mA	<sup>*B</sup>
Total maximum clamp current	Σ I <sub>CLAMP</sub>	-	65	mA	<sup>*C</sup>
"L"-level maximum output current <sup>*3</sup>	I <sub>OL1</sub>	-	3.5	mA	When setting is 1 mA <sup>*6, *7, *8</sup>
	I <sub>OL2</sub>	-	7	mA	When setting is 2 mA <sup>*6, *7, *8, *9</sup>
	I <sub>OL3</sub>	-	10	mA	When setting is 5 mA <sup>*9</sup>
	I <sub>OL4</sub>	-	16	mA	When setting is 10 mA <sup>*9</sup>
	I <sub>OL6</sub>	-	40	mA	When setting is 30 mA <sup>*7</sup>
	I <sub>OL7</sub>	-	8	mA	When setting is 3 mA <sup>*10</sup>
	I <sub>OL8</sub>	-	11	mA	When setting is 6 mA <sup>*11</sup>
	I <sub>OL9</sub>	-	21	mA	When setting is 15 mA <sup>*12</sup>
"L"-level average output current <sup>*4</sup>	I <sub>OLAV1</sub>	-	1	mA	When setting is 1 mA <sup>*6, *7, *8</sup>
	I <sub>OLAV2</sub>	-	2	mA	When setting is 2 mA <sup>*6, *7, *8, *9</sup>
	I <sub>OLAV3</sub>	-	5	mA	When setting is 5 mA <sup>*9</sup>
	I <sub>OLAV4</sub>	-	10	mA	When setting is 10 mA <sup>*9</sup>
	I <sub>OLAV6</sub>	-	30	mA	When setting is 30 mA <sup>*7</sup>
	I <sub>OLAV7</sub>	-	3	mA	When setting is 3 mA <sup>*10</sup>
	I <sub>OLAV8</sub>	-	6	mA	When setting is 6 mA <sup>*11</sup>
	I <sub>OLAV9</sub>	-	15	mA	When setting is 15 mA <sup>*12</sup>
"L"-level total output current <sup>*5</sup>	ΣI <sub>OL1</sub>	-	50	mA	<sup>*6, *10</sup>
	ΣI <sub>OL2</sub>	-	250	mA	<sup>*7</sup>

Parameter	Symbol	Rating		Unit	Remarks
		Min	Max		
"L"-level total output current <sup>*5</sup>	$\Sigma I_{OL3}$	-	50	mA	<sup>*8</sup>
	$\Sigma I_{OL4}$	-	50	mA	<sup>*9, *11</sup>
"H"-level maximum output current <sup>*3</sup>	$I_{OH1}$	-	-3.5	mA	When setting is 1 mA <sup>*6, *7, *8</sup>
	$I_{OH2}$	-	-7	mA	When setting is 2 mA <sup>*6, *7, *8, *9</sup>
	$I_{OH3}$	-	-10	mA	When setting is 5 mA <sup>*9</sup>
	$I_{OH4}$	-	-16	mA	When setting is 10 mA <sup>*9</sup>
	$I_{OH6}$	-	-40	mA	When setting is 30 mA <sup>*7</sup>
	$I_{OH8}$	-	-11	mA	When setting is 6 mA <sup>*11</sup>
	$I_{OH9}$	-	-21	mA	When setting is 15 mA <sup>*12</sup>
"H"-level average output current <sup>*4</sup>	$I_{OHAV1}$	-	-1	mA	When setting is 1 mA <sup>*6, *7, *8</sup>
	$I_{OHAV2}$	-	-2	mA	When setting is 2 mA <sup>*6, *7, *8, *9</sup>
	$I_{OHAV3}$	-	-5	mA	When setting is 5 mA <sup>*9</sup>
	$I_{OHAV4}$	-	-10	mA	When setting is 10 mA <sup>*9</sup>
	$I_{OHAV6}$	-	-30	mA	When setting is 30 mA <sup>*7</sup>
	$I_{OHAV8}$	-	-6	mA	When setting is 6 mA <sup>*11</sup>
	$I_{OHAV9}$	-	-15	mA	When setting is 15 mA <sup>*12</sup>
"H"-level total output current <sup>*5</sup>	$\Sigma I_{OH1}$	-	-50	mA	<sup>*6, *10</sup>
	$\Sigma I_{OH2}$	-	-250	mA	<sup>*7</sup>
	$\Sigma I_{OH3}$	-	-50	mA	<sup>*8</sup>
	$\Sigma I_{OH4}$	-	-50	mA	<sup>*9 *11</sup>
Power consumption	$P_D$	-	2000	mW	$-40\text{ }^\circ\text{C} \leq T_A \leq 105\text{ }^\circ\text{C}$
		-	1100	mW	$-40\text{ }^\circ\text{C} \leq T_A \leq 125\text{ }^\circ\text{C}$
Operating temperature	$T_A$	-40	+105	$^\circ\text{C}$	$P_D \leq 2000\text{ mW}$
		-40	+125	$^\circ\text{C}$	$P_D \leq 1100\text{ mW}$
System Thermal Resistance	Theta j-a1	-	17	$^\circ\text{C/W}$	TEQFP 208
	Theta j-a2	-	19	$^\circ\text{C/W}$	TEQFP 176
	Theta j-a3	-	20	$^\circ\text{C/W}$	TEQFP 144 (0.5 mm Pitch)
	Theta j-a4	-	22	$^\circ\text{C/W}$	TEQFP 144 (0.4 mm Pitch)
Package Thermal Resistance	Psi j-t1	-	0.6	$^\circ\text{C/W}$	TEQFP208
	Psi j-t2	-	1.0	$^\circ\text{C/W}$	TEQFP176
	Psi j-t3	-	2.0	$^\circ\text{C/W}$	TEQFP144 (0.5 mm Pitch)
	Psi j-t4	-	2.0	$^\circ\text{C/W}$	TEQFP144 (0.4 mm Pitch)
Storage temperature	$T_{stg}$	-55	+150	$^\circ\text{C}$	

\*1 These parameters are based on the condition that  $V_{SS} = AV_{SS} = DV_{SS} = 0.0\text{ V}$ .

\*2 Take care that  $DV_{CC}$ ,  $AV_{CC5}$  do not exceed  $V_{CC5}$  at, for example, the power-on time.

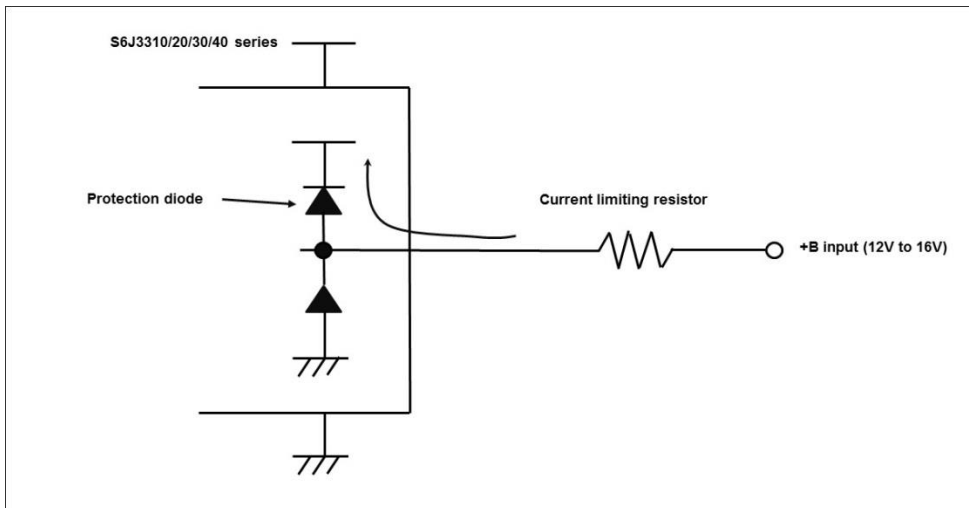
\*3 The maximum output current is defined as the value of the peak current flowing through any one of the corresponding pins.

\*4 The average output current is defined as the value of the average current flowing through any one of the corresponding pins for a 10 ms period. The average value is the operation current  $\times$  the operation ratio.

\*5 The total output current is defined as the maximum current value flowing through all of corresponding pins.

- \*6 Output of 5 V pins.
- \*7 Output of SMC pins.
- \*8 Output of 5 V/3 V pins.
- \*9 Output of 3 V pins.
- \*10 Output of I<sup>2</sup>C.
- \*11 Output of Media LB pins
- \*12 Output of DSP0\_CLK pins
- \*13 VI or VO should never exceed the specified ratings. However, if the maximum current to/from an input is limited by a suitable external resistor, the ICLAMP rating supersedes the VI rating.
- \*A Relevant pins: All general-purpose ports and analog input pins
  - Corresponding pins: all general-purpose ports
  - Use within recommended operating conditions.
  - Use at DC voltage (current).
  - The +B signal should always be applied by connecting a limiting resistor between the +B signal and the microcontroller.
  - The value of the limiting resistor should be set so that the current input to the microcontroller pin does not exceed rated values at any time regardless of instantaneously or constantly when the +B signal is input.
  - Note that when the microcontroller drive current is low, such as in the low power consumption modes, the + B input potential can increase the potential at the VCC pin via a protective diode, possibly affecting other devices.
  - Note that if the + B signal is input when the microcontroller is off (not fixed at 0 V), since the power is supplied through the pin, the microcontroller may operate incompletely.
  - Note that if the +B signal is input at power-on, since the power is supplied through the pin, the power-on reset may not function in the power supply voltage.
  - Do not leave + B input pins open.

Example of a recommended circuit



**WARNING:**

- Semiconductor devices may be permanently damaged by application of stress (including, without limitation, voltage, current or temperature) in excess of absolute maximum ratings. Do not exceed any of these ratings.

\*B Relevant pins: All general-purpose ports and analog input pins

- Corresponding pins: all general-purpose ports
  - Use within recommended operating conditions.
  - Use at DC voltage (current).
- MCU is operational, IO is driving LOW level (i.e. NMOS transistor active), there are negative biased pulses (-B signal) applied to active IO according to following specification (must not be exceeded).

Pulse condition specification:

U\_pulse = max -40 V  
 T\_pulse = max 1 ms  
 #\_pulse = max 5000

Current and Power Dissipation

U\_peak = -40 V  
 R\_serial = 22 k  
 => I\_pin = 1.8 mA

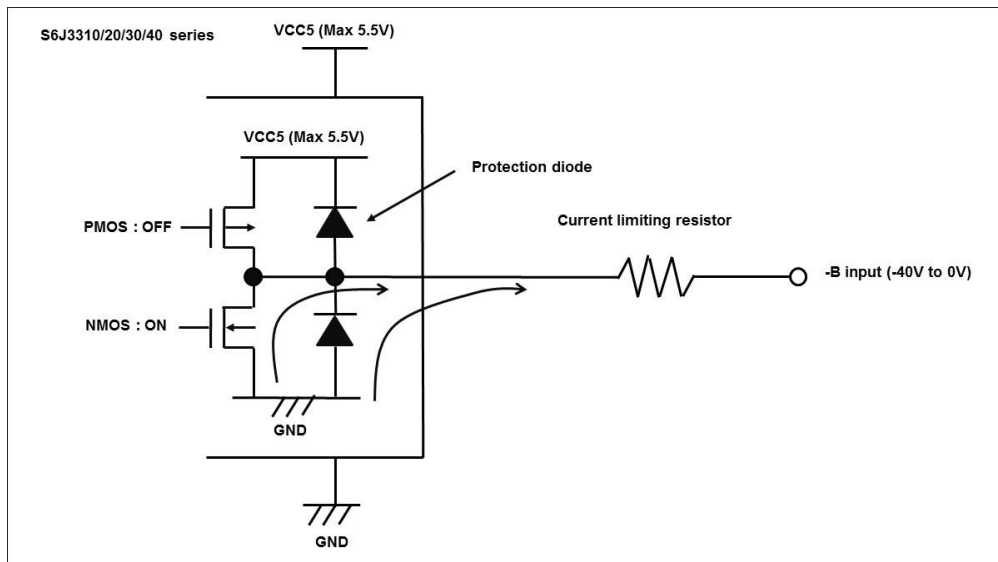
U\_out = -0.1 V (current drawn mainly over NMOS transistor)

=> I\_total = 50 pins x 1.8 mA = 90 mA  
 => P\_total = 50 pins x (1.8 mA x 0.1 V) = 9 mW

I\_total and P\_total are within allowed limits of extended specification.

- The - B signal should always be applied by connecting a limiting resistor between the - B signal and the microcontroller.
- The value of the limiting resistor should be set so that the current input to the microcontroller pin does not exceed rated values at any time regardless of instantaneously or constantly when the - B signal is input.
- Do not leave - B input pins open.

Example of a recommended circuit



**WARNING:**

- Semiconductor devices may be permanently damaged by application of stress (including, without limitation, voltage, current or temperature) in excess of absolute maximum ratings. Do not exceed any of these ratings.

\*C Relevant pins: All general-purpose ports and analog input pins

- Corresponding pins: all general-purpose ports
- Use within non operation conditions. The device is not supplied (VCC5: off, VCC12: off, VCC53: off).
- Use at DC voltage (current).

MCU is non-operational, PCB is in reverse polarity condition (supply of the MCU is off), negative biased voltage level (-B signal) is applied to inactive IO according to following specification (must not be exceeded).

Reverse polarity condition specification:

$$U\_reverse = \max -28 \text{ V}$$

$$T\_reverse = \max 4 \text{ h}$$

Current and Power Dissipation

$$U\_reverse = -28 \text{ V}$$

$$R\_serial = 22 \text{ k}$$

$$\Rightarrow I\_pin = 1.3 \text{ mA}$$

$$U\_out = -0.7 \text{ V (current drawn mainly over clamping diodes)}$$

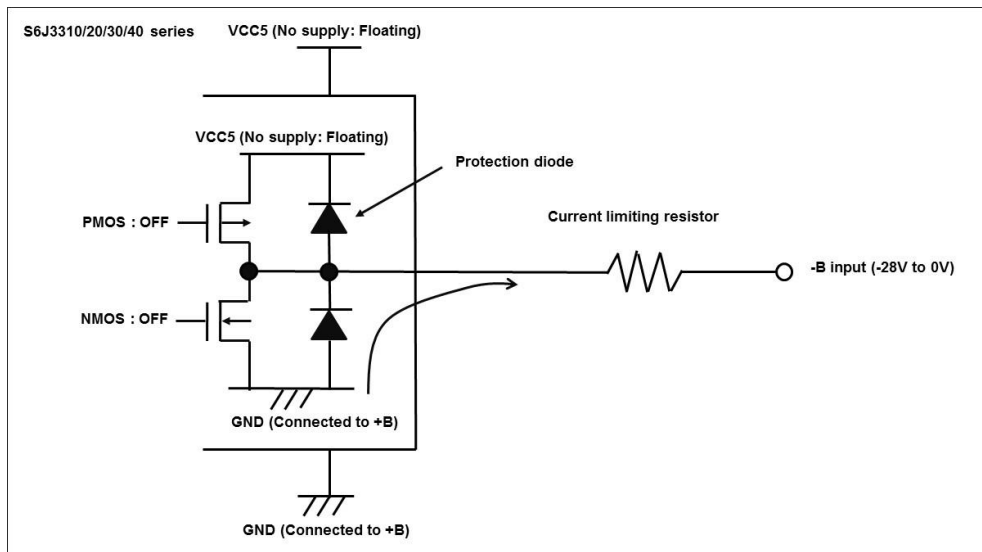
$$\Rightarrow I\_total = 50 \text{ pins} \times 1.3 \text{ mA} = 65 \text{ mA}$$

$$\Rightarrow P\_total = 50 \text{ pins} \times (1.3 \text{ mA} \times 0.7 \text{ V}) = 46 \text{ mW}$$

$I\_total$  and  $P\_total$  are within allowed limits of extended specification.

- The - B signal should always be applied by connecting a limiting resistor between the - B signal and the microcontroller.
- The value of the limiting resistor should be set so that the current input to the microcontroller pin does not exceed rated values at any time regardless of instantaneously or constantly when the - B signal is input.
- Do not leave - B input pins open.

Example of a recommended circuit



**WARNING:**

- Semiconductor devices may be permanently damaged by application of stress (including, without limitation, voltage, current or temperature) in excess of absolute maximum ratings. Do not exceed any of these ratings.

## 9.1.2 Recommended Operating Condition

Parameter	Symbol	Pin Name	Rating		Unit	Remarks
			Min	Max		
Supply voltage Recommended operation assurance range <sup>*4</sup>	V <sub>CC5</sub>	VCC5	4.5	5.5	V	*1
			3	3.6		*2 *3
	V <sub>CC53</sub>	VCC53	4.5	5.5	V	*1
			3	3.6		
	DV <sub>CC</sub>	DVCC	4.5	5.5	V	*1 *3
			3.0	3.6		*2
	AV <sub>CC5</sub>	AVCC5	4.5	5.5	V	*1
3			3.6	*2 *3		
V <sub>CC3</sub>	VCC3	3	3.6	V		
V <sub>CC12</sub>	VCC12	1.09	1.21	V		
AV <sub>CC3_DAC</sub>	AVCC3_DAC	3	3.6	V		
Supply voltage Operation assurance range	V <sub>CC5</sub>	VCC5	3.5	5.5	V	*1
			2.7	3.6		*2 *3
	V <sub>CC53</sub>	VCC53	2.7	5.5	V	*1
			2.7	3.6		
	DV <sub>CC</sub>	DVCC	3.5	5.5	V	*1 *3
			2.7	3.6		*2
	AV <sub>CC5</sub>	AVCC5	3.5	5.5	V	*1
2.7			3.6	*2 *3		
V <sub>CC3</sub>	VCC3	2.7	3.6	V		
V <sub>CC12</sub>	VCC12	1.09	1.21	V	*5	
AV <sub>CC3_DAC</sub>	AVCC3_DAC	2.7	3.6	V		
Smoothing capacitor*	C <sub>s</sub>	C	4.7		μF	Tolerance of up to ±40 %
Operating temperature	T <sub>A</sub>	-	-40	105	°C	P <sub>D</sub> ≤ 2000 mW
	T <sub>A</sub>	-	-40	125	°C	P <sub>D</sub> ≤ 1100 mW

\*1:For S6J33xxxSx or S6J33xxxUx or S6J33xxxTx or S6J33xxxVx option.

\*2:For S6J33xxxBx or S6J33xxxDx or S6J33xxxFx or S6J33xxxHx option.

\*3:For S6J33xxxAx or S6J33xxxCx or S6J33xxxEx or S6J33xxxGx option.

\*4:Corresponding functions for Low voltage monitoring of supply voltage are described in CHAPTER 13 Low Voltage Detection of *S6J3300 Series Hardware Manual*.

The detection/release threshold values of following LVD channels are potentially below supply range defined in 9.1.2 Recommended operating condition (refer to "9.1.4.11 Low Voltage Detection (External Voltage)" and "9.1.4.12 Low Voltage Detection (Internal Voltage)" for detection/release threshold values for these LVD channels):

LVDL0  
LVDL1  
LVDL2  
LVDH0  
LVDH1  
LVDH2

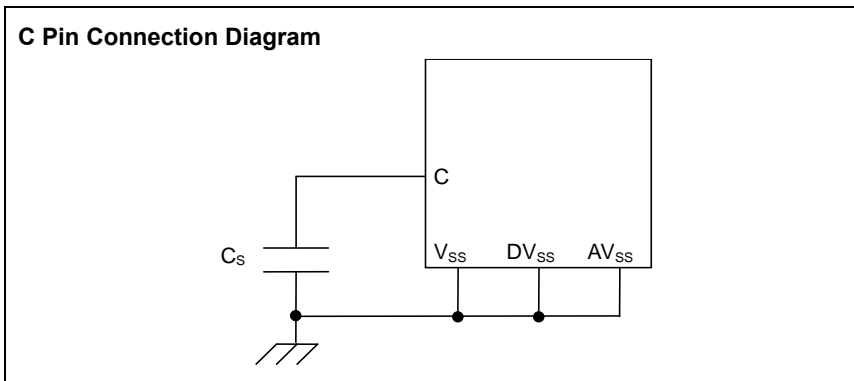


When it is used outside recommended range (this is the range of guaranteed operation), contact your sales representative. The initial detection voltage of the external low voltage detection is  $2.6\text{ V} \pm 3.5\%$ <sup>\*2 \*3</sup> (LVDH1/LVDH2) or  $0.8\text{ V} \pm 3.5\%$  (LVDL2). This LVD setting and internal LVD (LVDL0/LVDL1) cannot be used to reliably generate a reset before voltage dips below minimum guaranteed MCU operation voltage, as these detection levels are below the minimum guaranteed MCU operation voltage.

- Please use these LVD channels with your own risk
- Please monitor the external power supplies on the PCB if needed

\*5: When the voltage of Vcc12 is in the out of range against supply voltage operation assurance, the operation of circuit which Vcc12 used as the power source becomes unstable status. In that case, the value of each registers including RESCAUSEUR Register cannot be guaranteed, so these flags should don't care by software processing

\*: For the connections of smoothing capacitor Cs, see the following diagram.



**Notes:**

- The recommended operating conditions are required in order to ensure the normal operation of the semiconductor device. All of the electrical characteristics of the device are warranted when the device is operated within these ranges. Always use semiconductor devices within their recommended operating condition ranges. Operation outside these ranges may adversely affect reliability and could result in device failure. No warranty is made with respect to uses, operating conditions, or combinations not represented on the data sheet. Users considering application outside the listed conditions are advised to contact sales representatives beforehand.
- Required power supply sequence is the following:  
 {VCC5 -> AVCC5} -> [DVCC or VCC53 or VCC3 or AVCC3\_DAC or VCC12]  
 Note that power supplies inside "[ ]" can be turned on in arbitrary order and "{"}" can be turned on in shown sequence or simultaneously.

**Notes:**

- $T_A$ : Ambient temperature (JEDEC)
- $T_C$ : Case temperature (JEDEC), the maximum measured temperature of package case top.
- Both rating of  $T_A$  and  $T_C$  should simultaneously be satisfied as maximum operation temperature.
- The following condition should be satisfied in order to facilitate heat dissipation.
  1. Four or more layers PCB should be used.
  2. The area of PCB should be 114.3 mm x 76.2 mm or more, and the thickness should be 1.6 mm or more. (JEDEC standard)
  3. One layer of middle layers at least should be used for dedicated layer to radiate heat with residual copper rate 90 % or more. The layer can be used for system ground.
  4. 35 % or more of the die stage area which is exposed at back surface of package should be soldered to a part of 1<sup>st</sup> layer.
  5. The part of 1<sup>st</sup> layer should be connected to the dedicated heat radiation layer with more than 10 thermal via holes.

**Example thermal via holes on PCB**



- The above figure is a schematic diagram showing PCB in section.
- Thermal via holes should closely be placed and aligned with lands.
- It is recommended to connect the land pattern to the VSS-ground level (GND plan of inner layer bellow the MCU) as thermal heat sink.

**9.1.3 DC Characteristics**

(T<sub>A</sub>: Recommended operating conditions, V<sub>cc5</sub>, V<sub>cc53</sub> = 5.0 V ± 10 %, V<sub>cc3</sub> = 3.3 V ± 0.3 V, V<sub>SS</sub> = DV<sub>SS</sub> = AV<sub>SS</sub> = 0.0 V)

Parameter	Symbol	Pin Name	Conditions	Value			Unit	Remarks
				Min	Typ	Max		
"H" level Input voltage	V <sub>IH1</sub>	P0_00 to P0_20,	CMOS hysteresis input level is selected	0.7×V <sub>cc53</sub>	-	V <sub>cc53</sub> +0.3	V	
	V <sub>IH2</sub>	P2_09 to P2_19,	Automotive input level is selected	0.8×V <sub>cc53</sub>	-	V <sub>cc53</sub> +0.3	V	
	V <sub>IH3</sub>	P3_00 to P3_07, P3_24 to P3_31, P4_00 to P4_07	TTL input level is selected	2.0	-	V <sub>cc53</sub> +0.3	V	
	V <sub>IH4</sub>	P1_03 to P1_16, P3_08	CMOS hysteresis input level is selected	0.7×V <sub>cc5</sub>	-	V <sub>cc5</sub> +0.3	V	
	V <sub>IH5</sub>	to P3_23, P4_08 to P4_23	Automotive input level is selected	0.8×V <sub>cc5</sub>	-	V <sub>cc5</sub> +0.3	V	
	V <sub>IH6</sub>	P1_09, P1_10, P1_15, P1_16	TTL input level is selected	2.0	-	V <sub>cc5</sub> +0.3	V	
	V <sub>IH7</sub>	P1_17 to P1_31, P2_00	CMOS hysteresis input level is selected	0.7×DV <sub>cc</sub>	-	DV <sub>cc</sub> +0.3	V	
	V <sub>IH8</sub>	to P2_08, P4_24 to P4_31	Automotive input level is selected	0.8×DV <sub>cc</sub>	-	DV <sub>cc</sub> +0.3	V	
	V <sub>IH9</sub>	RSTX	-	0.7×V <sub>cc5</sub>	-	V <sub>cc5</sub> +0.3	V	
	V <sub>IH10</sub>	NMIX	-	0.7×V <sub>cc5</sub>	-	V <sub>cc5</sub> +0.3	V	
	V <sub>IH11</sub>	MD	-	0.7×V <sub>cc5</sub>	-	V <sub>cc5</sub> +0.3	V	
	V <sub>IH12</sub>	JTAG_NTRST JTAG_TCK JTAG_TDI JTAG_TMS	-	2.7	-	V <sub>cc5</sub> +0.3	V	
	V <sub>IH13</sub>	P0_21 to P0_31, P1_00 to P1_02	CMOS hysteresis input level is selected	0.7×V <sub>cc3</sub>	-	V <sub>cc3</sub> +0.3	V	
	V <sub>IH14</sub>	P0_21 to P0_31	TTL input level is selected	2.0	-	V <sub>cc3</sub> +0.3	V	
	P1_00 to P1_02	-	1.7	-	V <sub>cc3</sub> +0.3	V	MediaLB	

(TA: Recommended operating conditions,  $V_{cc5}, V_{cc53} = 5.0\text{ V} \pm 10\%$ ,  $V_{cc3} = 3.3\text{ V} \pm 0.3\text{ V}$ ,  $V_{ss} = DV_{ss} = AV_{ss} = 0.0\text{ V}$ )

Parameter	Symbol	Pin Name	Conditions	Value			Unit	Remarks
				Min	Typ	Max		
"L" level Input voltage	V <sub>IL1</sub>	P0_00 to P0_20, P2_09 to P2_19, P3_00 to P3_07, P3_24 to P3_31, P4_00 to P4_07	CMOS hysteresis input level is selected	V <sub>ss</sub> -0.3	-	$0.3 \times V_{cc5}$ 3	V	
	V <sub>IL2</sub>		Automotive input level is selected	V <sub>ss</sub> -0.3	-	$0.5 \times V_{cc5}$ 3	V	
	V <sub>IL3</sub>		TTL input level is selected	V <sub>ss</sub> -0.3	-	0.8	V	
	V <sub>IL4</sub>	P1_03 to P1_16, P3_08 to P3_23, P4_08 to P4_23	CMOS hysteresis input level is selected	V <sub>ss</sub> -0.3	-	$0.3 \times V_{cc5}$	V	
	V <sub>IL5</sub>		Automotive input level is selected	V <sub>ss</sub> -0.3	-	$0.5 \times V_{cc5}$	V	
	V <sub>IL6</sub>	P1_09, P1_10, P1_15, P1_16	TTL input level is selected	V <sub>ss</sub> -0.3	-	0.8	V	
	V <sub>IL7</sub>	P1_17 to P1_31, P2_00 to P2_08, P4_24 to P4_31	CMOS hysteresis input level is selected	V <sub>ss</sub> -0.3	-	$0.3 \times DV_{c}$ c	V	
	V <sub>IL8</sub>		Automotive input level is selected	V <sub>ss</sub> -0.3	-	$0.5 \times DV_{c}$ c	V	
	V <sub>IL9</sub>	RSTX NMIX	-	V <sub>ss</sub> -0.3	-	$0.3 \times V_{cc5}$	V	
	V <sub>IL10</sub>	MD	-	V <sub>ss</sub> -0.3	-	$0.3 \times V_{cc5}$	V	
	V <sub>IL11</sub>	JTAG_NTRST JTAG_TCK JTAG_TDI JTAG_TMS	-	V <sub>ss</sub> -0.3	-	0.8	V	
	V <sub>IL12</sub>	P0_21 to P0_31, P1_00 to P1_02	CMOS hysteresis input level is selected	V <sub>ss</sub> -0.3	-	$0.3 \times V_{cc3}$	V	
	V <sub>IL13</sub>	P0_21 to P0_31	TTL input level is selected	V <sub>ss</sub> -0.3	-	0.8	V	
	V <sub>IL14</sub>	P1_00 to P1_02	-	V <sub>ss</sub> -0.3	-	0.7	V	MediaLB

Parameter	Symbol	Pin Name	Conditions	Value			Unit	Remarks
				Min	Typ	Max		
Hysteresis voltage	V <sub>HYS1</sub>	P0_00 to P0_20, P2_09 to P2_19, P3_00 to P3_07, P3_24 to P3_31, P4_00 to P4_07	CMOS hysteresis input level is selected	-	0.05×V <sub>cc53</sub>	-	V	
	V <sub>HYS2</sub>		Automotive input level is selected	-	0.03×V <sub>cc53</sub>	-	V	
	V <sub>HYS3</sub>		TTL input level is selected	-	0.035	-	V	
	V <sub>HYS4</sub>	P1_03 to P1_16, P3_08 to P3_23, P4_08 to P4_23	CMOS hysteresis input level is selected	-	0.05×V <sub>cc5</sub>	-	V	
	V <sub>HYS5</sub>		Automotive input level is selected	-	0.03×V <sub>cc5</sub>	-	V	
	V <sub>HYS6</sub>	P1_09, P1_10, P1_15, P1_16	TTL input level is selected	-	0.035	-	V	
	V <sub>HYS7</sub>	P1_17 to P1_31, P2_00 to P2_08, P4_24 to P4_31	CMOS hysteresis input level is selected	-	0.05×D <sub>VCC</sub>	-	V	
	V <sub>HYS8</sub>		Automotive input level is selected	-	0.03×D <sub>VCC</sub>	-	V	
	V <sub>HYS9</sub>	RSTX NMIX	-	-	0.05×V <sub>cc5</sub>	-	V	
	V <sub>HYS10</sub>	MD	-	-	0.05×V <sub>cc5</sub>	-	V	
	V <sub>HYS11</sub>	JTAG_NTRST JTAG_TCK JTAG_TDI JTAG_TMS	-	-	0.035	-	V	
	V <sub>HYS12</sub>	P0_21 to P0_31, P1_00 to P1_02	CMOS hysteresis input level is selected	-	0.05×V <sub>cc3</sub>	-	V	
	V <sub>HYS13</sub>	P0_21 to P0_31	TTL input level is selected	-	0.035	-	V	
	V <sub>HYS14</sub>	P1_00 to P1_02	-	-	0.080	-	V	MediaLB

(TA: Recommended operating conditions, V<sub>CC5</sub>, V<sub>CC53</sub>, DV<sub>CC</sub> = 5.0 V ± 10 %, V<sub>CC3</sub> = 3.3 V ± 0.3 V, V<sub>SS</sub> = DV<sub>SS</sub> = AV<sub>SS</sub> = 0.0 V)

Parameter	Symbol	Pin Name	Conditions	Value			Unit	Remarks	
				Min	Typ	Max			
"H" level output voltage	V <sub>OH1</sub>	P0_00 to P0_19, P2_09 to P2_11, P2_13 to P2_19, P3_00 to P3_07, P3_24 to P3_31, P4_00 to P4_07	V <sub>CC53</sub> = 4.5 V I <sub>OH</sub> = -1.0 mA	V <sub>CC53</sub> - 0.5	-	V <sub>CC53</sub>	V	ODR[1:0]=2b00	
			V <sub>CC53</sub> = 3.0 V I <sub>OH</sub> = -0.5 mA						
	V <sub>OH2</sub>		V <sub>CC53</sub> = 4.5 V I <sub>OH</sub> = -2.0 mA	V <sub>CC53</sub> - 0.5	-	V <sub>CC53</sub>	V		ODR[1:0]=2b01
			V <sub>CC53</sub> = 3.0 V I <sub>OH</sub> = -1.0 mA						
	V <sub>OH3</sub>		V <sub>CC53</sub> = 4.5 V I <sub>OH</sub> = -5.0 mA	V <sub>CC53</sub> - 0.5	-	V <sub>CC53</sub>	V		ODR[1:0]=2b10
			V <sub>CC53</sub> = 3.0 V I <sub>OH</sub> = -2.0 mA						
	V <sub>OH4</sub>	P1_03 to P1_16, P3_08 to P3_23, P4_08 to P4_23	V <sub>CC5</sub> = 4.5 V I <sub>OH</sub> = -1.0 mA	V <sub>CC5</sub> - 0.5	-	V <sub>CC5</sub>	V		
	V <sub>OH5</sub>		V <sub>CC5</sub> = 4.5 V I <sub>OH</sub> = -2.0 mA	V <sub>CC5</sub> - 0.5	-	V <sub>CC5</sub>	V		
	V <sub>OH6</sub>		V <sub>CC5</sub> = 4.5 V I <sub>OH</sub> = -5.0 mA	V <sub>CC5</sub> - 0.5	-	V <sub>CC5</sub>	V		
	V <sub>OH7</sub>	PSC_1	V <sub>CC5</sub> = 4.5 V I <sub>OH</sub> = -2.0 mA	V <sub>CC5</sub> - 0.5	-	V <sub>CC5</sub>	V		
	V <sub>OH8</sub>	JTAG_TDO	V <sub>CC5</sub> = 4.5 V I <sub>OH</sub> = -5.0 mA	V <sub>CC5</sub> - 0.5	-	V <sub>CC5</sub>	V		
	V <sub>OH10</sub>	P1_17 to P1_31, P2_00 to P2_08, P4_24 to P4_31	DV <sub>CC</sub> = 4.5 V I <sub>OH</sub> = -1.0 mA	DV <sub>CC</sub> - 0.5	-	DV <sub>CC</sub>	V		
	V <sub>OH11</sub>		DV <sub>CC</sub> = 4.5 V I <sub>OH</sub> = -2.0 mA	DV <sub>CC</sub> - 0.5	-	DV <sub>CC</sub>	V		
	V <sub>OH12</sub>		DV <sub>CC</sub> = 4.5 V I <sub>OH</sub> = -5.0 mA	DV <sub>CC</sub> - 0.5	-	DV <sub>CC</sub>	V		
	V <sub>OH13</sub>		DV <sub>CC</sub> = 4.5 V I <sub>OH</sub> = -30.0 mA	DV <sub>CC</sub> - 0.5	-	DV <sub>CC</sub>	V	SMC	
	V <sub>OH14</sub>		DV <sub>CC</sub> = 4.5 V I <sub>OH</sub> = -40.0 mA	DV <sub>CC</sub> - 0.5	-	DV <sub>CC</sub>	V	SMC T <sub>j</sub> = -40 °C	
	V <sub>OH15</sub>		P0_21 to P0_31, P1_00 to P1_02	V <sub>CC3</sub> = 3.0 V I <sub>OH</sub> = -2.0 mA	V <sub>CC3</sub> - 0.5	-	V <sub>CC3</sub>	V	
	V <sub>OH16</sub>			V <sub>CC3</sub> = 3.0 V I <sub>OH</sub> = -5.0 mA	V <sub>CC3</sub> - 0.5	-	V <sub>CC3</sub>	V	
V <sub>OH17</sub>	V <sub>CC3</sub> = 3.0 V I <sub>OH</sub> = -6.0 mA			V <sub>CC3</sub> - 0.5	-	V <sub>CC3</sub>	V		
V <sub>OH18</sub>	V <sub>CC3</sub> = 3.0 V I <sub>OH</sub> = -15.0 mA	V <sub>CC3</sub> - 0.5		-	V <sub>CC3</sub>	V			

(T<sub>A</sub>: Recommended operating conditions, V<sub>CC5</sub>, V<sub>CC53</sub>, DV<sub>CC</sub> = 5.0 V ± 10%, V<sub>CC3</sub> = 3.3 V ± 0.3 V, V<sub>SS</sub> = DV<sub>SS</sub> = AV<sub>SS</sub> = 0.0 V)

Parameter	Symbol	Pin Name	Conditions	Value			Unit	Remarks
				Min	Typ	Max		
"H" level output voltage	V <sub>OH19</sub>	P2_12	V <sub>CC53</sub> = 4.5 V I <sub>OH</sub> = -1.0 mA	V <sub>CC53</sub> - 0.5	-	V <sub>CC53</sub>	V	ODR[1:0] = 2b00
	V <sub>OH20</sub>		V <sub>CC53</sub> = 3.0 V I <sub>OH</sub> = -0.5 mA					
	V <sub>OH21</sub>		V <sub>CC53</sub> = 4.5 V I <sub>OH</sub> = -2.0 mA	V <sub>CC53</sub> - 0.5	-	V <sub>CC53</sub>	V	ODR[1:0] = 2b01
	V <sub>OH22</sub>		V <sub>CC53</sub> = 3.0 V I <sub>OH</sub> = -1.0 mA					
	V <sub>OH23</sub>		V <sub>CC53</sub> = 4.5 V I <sub>OH</sub> = -5.0 mA	V <sub>CC53</sub> - 0.5	-	V <sub>CC53</sub>	V	ODR[1:0] = 2b10
	V <sub>OH24</sub>		V <sub>CC53</sub> = 3.0 V I <sub>OH</sub> = -2.0 mA					
	V <sub>OH26</sub>		V <sub>CC53</sub> = 3.0 V I <sub>OH</sub> = -15.0 mA	V <sub>CC53</sub> - 0.5	-	V <sub>CC53</sub>	V	ODR[1:0] = 2b11

(TA: Recommended operating conditions,  $V_{CC5}, V_{CC53}, DV_{CC} = 5.0 \text{ V} \pm 10 \%$ ,  $V_{CC3} = 3.3 \text{ V} \pm 0.3 \text{ V}$ ,  $V_{SS} = DV_{SS} = AV_{SS} = 0.0 \text{ V}$ )

Parameter	Symbol	Pin Name	Conditions	Value			Unit	Remarks	
				Min	Typ	Max			
"L" level output voltage	V <sub>OL1</sub>	P0_00 to P0_19, P2_09 to P2_11, P2_13 to P2_19, P3_00 to P3_07, P3_24 to P3_31, P4_00 to P4_07	V <sub>CC53</sub> = 4.5 V I <sub>OL</sub> = 1.0 mA	0	-	0.4	V	ODR[1:0] = 2b00	
			V <sub>CC53</sub> = 3.0 V I <sub>OL</sub> = 0.5 mA						
	V <sub>OL2</sub>		V <sub>CC53</sub> = 4.5 V I <sub>OL</sub> = 2.0 mA	0	-	0.4	V	ODR[1:0] = 2b01	
			V <sub>CC53</sub> = 3.0 V I <sub>OL</sub> = 1.0 mA						
	V <sub>OL3</sub>		V <sub>CC53</sub> = 4.5 V I <sub>OL</sub> = 5.0 mA	0	-	0.4	V	ODR[1:0] = 2b10	
			V <sub>CC53</sub> = 3.0 V I <sub>OL</sub> = 2.0 mA						
	V <sub>OL4</sub>		V <sub>CC5</sub> = 4.5 V I <sub>OL</sub> = 1.0 mA	0	-	0.4	V		
	V <sub>OL5</sub>		V <sub>CC5</sub> = 4.5 V I <sub>OL</sub> = 2.0 mA	0	-	0.4	V		
	V <sub>OL6</sub>		V <sub>CC5</sub> = 4.5 V I <sub>OL</sub> = 5.0 mA	0	-	0.4	V		
	V <sub>OL7</sub>		PSC_1	V <sub>CC5</sub> = 4.5 V I <sub>OL</sub> = 2.0 mA	0	-	0.4	V	
	V <sub>OL8</sub>		JTAG_TDO	V <sub>CC5</sub> = 4.5 V I <sub>OL</sub> = 5.0 mA	0	-	0.4	V	
	V <sub>OL9</sub>		P1_09, P1_10, P1_15, P1_16	V <sub>CC5</sub> = 4.5 V I <sub>OL</sub> = 3.0 mA	0	-	0.4	V	I <sup>2</sup> C
	V <sub>OL10</sub>		P1_17 to P1_31, P2_00 to P2_08, P4_24 to P4_31	DV <sub>CC</sub> = 4.5 V I <sub>OL</sub> = 1.0 mA	0	-	0.4	V	
	V <sub>OL11</sub>			DV <sub>CC</sub> = 4.5 V I <sub>OL</sub> = 2.0 mA	0	-	0.4	V	
	V <sub>OL12</sub>			DV <sub>CC</sub> = 4.5 V I <sub>OL</sub> = 5.0 mA	0	-	0.4	V	
	V <sub>OL13</sub>			DV <sub>CC</sub> = 4.5 V I <sub>OL</sub> = 30.0 mA	0	-	0.55	V	SMC
	V <sub>OL14</sub>			DV <sub>CC</sub> = 4.5 V I <sub>OL</sub> = 40.0 mA	0	-	0.55	V	SMC T <sub>j</sub> = -40 °C
	V <sub>OL15</sub>			V <sub>CC3</sub> = 3.0 V I <sub>OL</sub> = 2.0 mA	0	-	0.4	V	
V <sub>OL16</sub>	V <sub>CC3</sub> = 3.0 V I <sub>OL</sub> = 5.0 mA	0		-	0.4	V			
V <sub>OL17</sub>	V <sub>CC3</sub> = 3.0 V I <sub>OL</sub> = 6.0 mA	0		-	0.4	V			
V <sub>OL18</sub>	V <sub>CC3</sub> = 3.0 V I <sub>OL</sub> = 15.0 mA	0	-	0.4	V				



(TA: Recommended operating conditions,  $V_{CC5}, V_{CC53}, DV_{CC} = 5.0 \text{ V} \pm 10 \%$ ,  $V_{CC3} = 3.3 \text{ V} \pm 0.3 \text{ V}$ ,  $V_{SS} = DV_{SS} = AV_{SS} = 0.0 \text{ V}$ )

Parameter	Symbol	Pin Name	Conditions	Value			Unit	Remarks
				Min	Typ	Max		
"L" level output voltage	$V_{OL19}$	P2_12	$V_{CC53} = 4.5 \text{ V}$ $I_{OL} = 1.0 \text{ mA}$	0	-	0.4	V	ODR[1:0] = 2b00
	$V_{OL20}$		$V_{CC53} = 3.0 \text{ V}$ $I_{OL} = 0.5 \text{ mA}$					
	$V_{OL21}$		$V_{CC53} = 4.5 \text{ V}$ $I_{OL} = 2.0 \text{ mA}$	0	-	0.4	V	ODR[1:0] = 2b01
	$V_{OL22}$		$V_{CC53} = 3.0 \text{ V}$ $I_{OL} = 1.0 \text{ mA}$					
	$V_{OL23}$		$V_{CC53} = 4.5 \text{ V}$ $I_{OL} = 5.0 \text{ mA}$	0	-	0.4	V	ODR[1:0] = 2b10
	$V_{OL24}$		$V_{CC53} = 3.0 \text{ V}$ $I_{OL} = 2.0 \text{ mA}$					
	$V_{OL26}$		$V_{CC53} = 3.0 \text{ V}$ $I_{OL} = 15.0 \text{ mA}$	0	-	0.4	V	ODR[1:0] = 2b11

(TA: Recommended operating conditions,  $V_{CC5}, V_{CC53}, DV_{CC} = 5.0 \text{ V} \pm 10 \%$ ,  $V_{CC3} = 3.3 \text{ V} \pm 0.3 \text{ V}$ ,  $V_{SS} = DV_{SS} = AV_{SS} = 0.0 \text{ V}$ )

Parameter	Symbol	Pin Name	Conditions	Value			Unit	Remarks
				Min	Typ	Max		
Input leakage current	I <sub>IL</sub>	P0_00 to P0_20, P1_03 to P1_31, P2_00 to P2_19, P3_00 to P3_31, P4_00 to P4_31	$V_{CC5} = V_{CC53} =$ $DV_{CC} =$ $AV_{CC} = 5.5 \text{ V}$ $V_{SS} < V_I < V_{CC}$	-5	-	+5	μA	5 V pins 5 V/3 V pins
		P0_21 to P0_31, P1_00 to P1_02	$V_{CC3} = 3.6 \text{ V}$ $V_{SS} < V_I < V_{CC3}$	-10	-	+10	μA	3 V pins
Pull-up resistor	R <sub>UP1</sub>	RSTX, NMIX	-	25	50	100	kΩ	
	R <sub>UP2</sub>	P0_00 to P0_20, P1_03 to P1_31, P2_00 to P2_19, P3_00 to P3_31, P4_00 to P4_31	Pull-up resistor selected	25	50	100	kΩ	5 V pins 5 V/3 V pins
	R <sub>UP3</sub>	P0_21 to P0_31, P1_00 to P1_02	Pull-up resistor selected	17	50	66	kΩ	3 V pins
	R <sub>UP4</sub>	JTAG_TDI, JTAG_TMS, JTAG_TCK	-	25	50	100	kΩ	
Pull-down resistor	R <sub>down1</sub>	P0_00 to P0_20, P1_03 to P1_31, P2_00 to P2_19, P3_00 to P3_31, P4_00 to P4_31	Pull-down resistor selected	25	50	100	kΩ	5 V pins 5 V/3 V pins
	R <sub>down2</sub>	P0_21 to P0_31, P1_00 to P1_02	Pull-down resistor selected	17	50	66	kΩ	3 V pins
	R <sub>down3</sub>	JTAG_NTRST	-	25	50	100	kΩ	
Input capacitance	C <sub>IN1</sub>	P0_00 to P0_31, P1_00 to P1_16, P2_09 to P2_19, P3_00 to P3_31, P4_00 to P4_23	-	-	5	15	pF	
	C <sub>IN2</sub>	P1_17 to P1_31, P2_00 to P2_08, P4_24 to P4_31	-	-	15	45	pF	When using SMC

(T<sub>A</sub>: Recommended operating conditions, V<sub>CC5</sub>,V<sub>CC53</sub>,DV<sub>CC</sub> = 5.0 V ± 10 %, V<sub>CC3</sub> = 3.3 V ± 0.3 V, V<sub>CC12</sub> = 1.15 V ± 0.06 V, V<sub>SS</sub> = DV<sub>SS</sub> = AV<sub>SS</sub> = 0.0 V)

Parameter	Symbol	Pin Name	Conditions	Value			Unit	Remarks
				Min	Typ	Max		
Power supply current	I <sub>CC12</sub>	VCC12	Normal operation	-	315	775	mA	T <sub>A</sub> = -40 ~ 105 °C CPU:240MHz, HPM:120 MHz (CPU:200 MHz, HPM:200 MHz) GDC: 200 MHz
				-	-	395	mA	Example use case *1 T <sub>A</sub> = -40 ~ 105 °C CPU:60 MHz, HPM:60 MHz GDC: 60 MHz
			Flash write/erase	-	320	780	mA	T <sub>A</sub> = -40 ~ 105 °C CPU:240 MHz, HPM:120 MHz (CPU:200 MHz, HPM:200 MHz) GDC: 200 MHz
	I <sub>CH12</sub>		Timer/ Stop Mode	-	-	420	mA	
	I <sub>CC5</sub>	VCC5	Normal operation	-	25	45	mA	
			Flash write/erase	-	-	60	mA	

(T<sub>A</sub>: Recommended operating conditions, V<sub>CC5</sub>, V<sub>CC53</sub>, DV<sub>CC</sub> = 5.0 V ± 10 %, V<sub>CC3</sub> = 3.3 V ± 0.3 V, V<sub>CC12</sub> = 1.15 V ± 0.06 V, V<sub>SS</sub> = DV<sub>SS</sub> = AV<sub>SS</sub> = 0.0 V)

Parameter	Symbol	Pin Name	Conditions	Value			Unit	Remarks
				Min	Typ	Max		
Power supply current	I <sub>CC5</sub>	VCC5	Timer mode	-	370	810	μA	T <sub>A</sub> = 25 °C. 4 MHz crystal for main oscillator PD1 = ON, PD4_0 = ON, PD4_1 = ON
				-	360	780	μA	T <sub>A</sub> = 25 °C. 4 MHz crystal for main oscillator. PD1 = ON, PD4_0 = ON or PD4_1 = ON
				-	350	750	μA	T <sub>A</sub> = 25 °C. 4 MHz crystal for main oscillator. PD1 = ON
				-	450	890	μA	T <sub>A</sub> = 25 °C. 8 MHz crystal for main oscillator PD1 = ON, PD4_0 = ON, PD4_1 = ON
				-	440	860	μA	T <sub>A</sub> = 25 °C. 8 MHz crystal for main oscillator. PD1 = ON, PD4_0 = ON or PD4_1 = ON
				-	430	830	μA	T <sub>A</sub> = 25 °C. 8 MHz crystal for main oscillator. PD1 = ON
				-	110	430	μA	T <sub>A</sub> = 25 °C. 32 kHz crystal for sub oscillator PD1 = ON, PD4_0 = ON, PD4_1 = ON
				-	100	400	μA	T <sub>A</sub> = 25 °C. 32 kHz crystal for sub oscillator. PD1 = ON, PD4_0 = ON or PD4_1 = ON
	-		90	370	μA	T <sub>A</sub> = 25 °C. 32 kHz crystal for sub oscillator. PD1 = ON		
	I <sub>CC5</sub>		Stop mode	-	100	400	μA	T <sub>A</sub> = 25 °C. PD1 = ON, PD4_0 = ON, PD4_1 = ON
				-	90	370	μA	T <sub>A</sub> = 25 °C. PD1 = ON, PD4_0 = ON or PD4_1 = ON
-		80		340	μA	T <sub>A</sub> = 25 °C. PD1 = ON		

- \*1: Example use case at following condition  
 CPU:60MHz, HPM:60MHz, GDC: 60MHz  
 Peripherals:  
 - DMAC active (WorkFlash => SystemRAM)  
 - All timers active  
 - 6 SMCs, 1 CAN, 2LIN, 1SPI, PWMs, ADCs  
 Display controller:  
 - 2 (= all) layers active (60 MHz, noise RGBA, 32 bpp, 2048 x 5 pixels)  
 - Any other resources inactive  
 - IOs no toggle

(T<sub>A</sub>: Recommended operating conditions, V<sub>CC5</sub>, V<sub>CC53</sub>, DV<sub>CC</sub> = 5.0 V ± 10 %, V<sub>CC3</sub> = 3.3 V ± 0.3 V, V<sub>CC12</sub> = 1.15 V ± 0.06 V, V<sub>SS</sub> = DV<sub>SS</sub> = AV<sub>SS</sub> = 0.0 V)

Parameter	Symbol	Pin Name	Conditions	Value			Unit	Remarks
				Min	Typ	Max		
Power supply current *	I <sub>CC5</sub>	VCC5	Timer mode	-	345	630	μA	T <sub>A</sub> = 25 °C. 4 MHz crystal for main oscillator PD1 = ON, PD4_0 = ON, PD4_1 = ON
				-	340	625	μA	T <sub>A</sub> = 25 °C. 4 MHz crystal for main oscillator. PD1 = ON, PD4_0 = ON or PD4_1 = ON
				-	335	620	μA	T <sub>A</sub> = 25 °C. 4 MHz crystal for main oscillator. PD1 = ON
				-	420	705	μA	T <sub>A</sub> = 25 °C. 8 MHz crystal for main oscillator PD1 = ON, PD4_0 = ON, PD4_1 = ON
				-	415	700	μA	T <sub>A</sub> = 25 °C. 8 MHz crystal for main oscillator. PD1 = ON, PD4_0 = ON or PD4_1 = ON
				-	410	695	μA	T <sub>A</sub> = 25 °C. 8 MHz crystal for main oscillator. PD1 = ON
				-	80	135	μA	T <sub>A</sub> = 25 °C. 32 kHz crystal for sub oscillator PD1 = ON, PD4_0 = ON, PD4_1 = ON
				-	75	130	μA	T <sub>A</sub> = 25 °C. 32 kHz crystal for sub oscillator. PD1 = ON, PD4_0 = ON or PD4_1 = ON
				-	70	125	μA	T <sub>A</sub> = 25 °C. 32 kHz crystal for sub oscillator. PD1 = ON
	I <sub>CC5</sub>	VCC5	Stop mode	-	75	130	μA	T <sub>A</sub> = 25 °C. PD1 = ON, PD4_0 = ON, PD4_1 = ON
				-	70	125	μA	T <sub>A</sub> = 25 °C. PD1 = ON, PD4_0 = ON or PD4_1 = ON
				-	65	120	μA	T <sub>A</sub> = 25 °C. PD1 = ON

\* Electric Characteristics for S6J33xxxxE.

(TA: Recommended operating conditions,  $V_{CC5}, V_{CC53}, DV_{CC} = 5.0 \text{ V} \pm 10 \%$ ,  $V_{CC3} = 3.3 \text{ V} \pm 0.3 \text{ V}$ ,  $V_{CC12} = 1.15 \text{ V} \pm 0.06 \text{ V}$ ,  $V_{SS} = DV_{SS} = AV_{SS} = 0.0 \text{ V}$ )

Parameter	Symbol	Pin Name	Conditions	Value			Unit	Remarks
				Min	Typ	Max		
High current output drive capacity Phase-to-phase deviation1	Delta- $V_{OH13}$	PWM1Pn, PWM1Mn, PWM2Pn, PWM2Mn (n = 0 to 5)	$DV_{CC} = 4.5 \text{ V}$ $I_{OH} = -30.0 \text{ mA}$ Maximum deviation of $V_{OH13}$	-	-	90	mV	*
High current output drive capacity Phase-to-phase deviation2	Delta- $V_{OL13}$		$DV_{CC} = 4.5 \text{ V}$ $I_{OL} = 30.0 \text{ mA}$ Maximum deviation of $V_{OL13}$	-	-	90	mV	*
LCD divider resistor	$R_{LCD}$	V0 to V1, V1 to V2, V2 to V3	-	6.25	12.5	25	k $\Omega$	
COM0 to COM3 output impedance	$R_{VCOM}$	COMm (m = 0 to 3)	-	-	-	4.5	k $\Omega$	
SEG00 to SEG31 output impedance	$R_{VSEG}$	SEGN (n = 00 to 31)	-	-	-	17	k $\Omega$	
LCDC leak current	$I_{LCDC}$	V0 to V3, COMm (m = 0 to 3), SEGN (n = 00 to 31)	$T_A = 25 \text{ }^\circ\text{C}$	-0.5	-	+0.5	$\mu\text{A}$	

\*: If PWM1P0/PWM1M0/PWM2P0/PWM2M0 of ch.0 is turned on simultaneously, the maximum deviation of  $V_{OH13}$  /  $V_{OL13}$  for each pin is defined. Same for other channels.

## 9.1.4 AC Characteristics

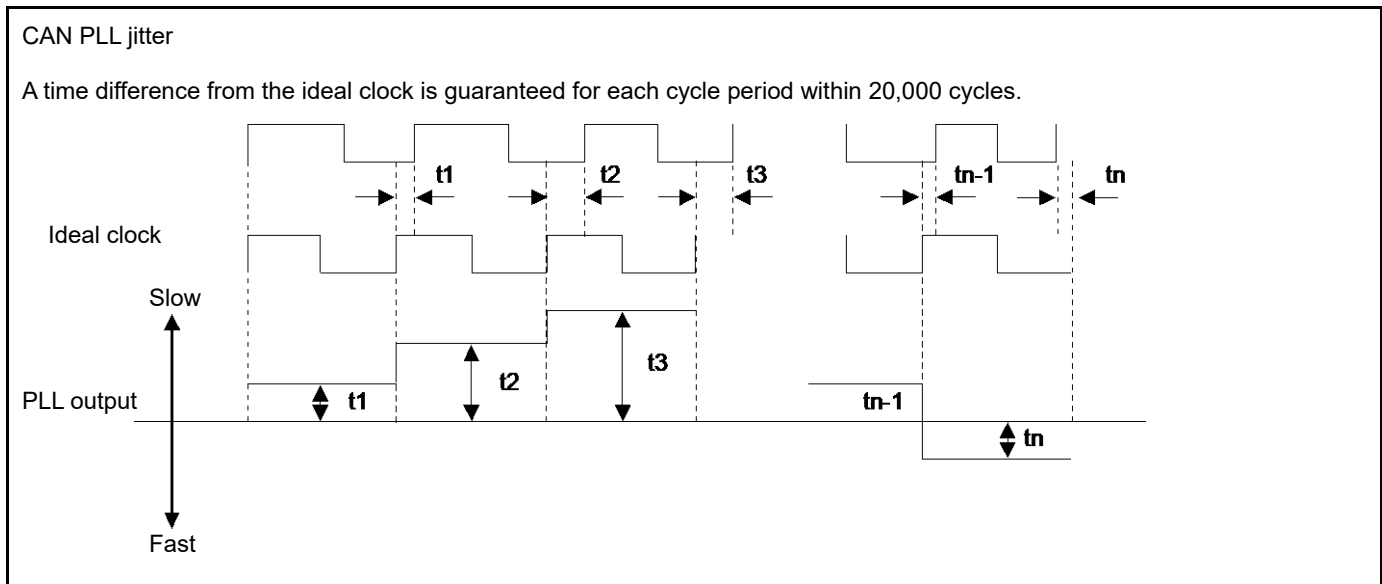
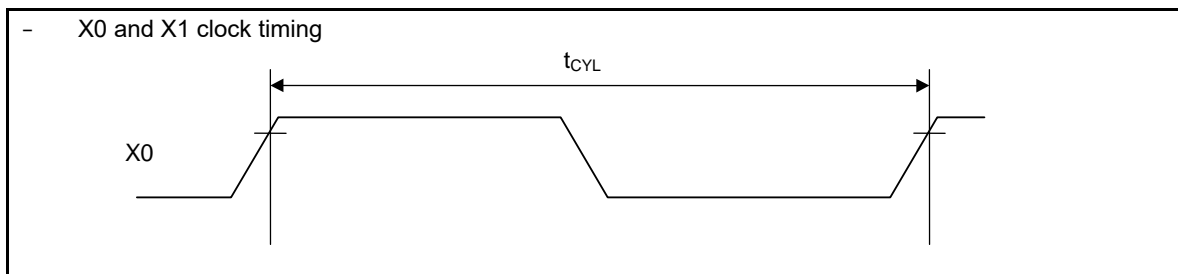
### 9.1.4.1 Source Clock Timing

(T<sub>A</sub>: Recommended operating conditions, V<sub>CC5</sub> = 5.0 V ±10 %, V<sub>SS</sub> = DV<sub>SS</sub> = AV<sub>SS</sub> = 0.0 V)

Parameter	Symbol	Pin Name	Conditions	Value			Unit	Remarks
				Min	Typ	Max		
Source oscillation clock frequency	F <sub>C</sub>	X0, X1	-	3.6	-	16.0	MHz	
Source oscillation clock cycle time	t <sub>CYL</sub>	X0, X1	-	62.5	-	277.8	ns	
CAN PLL jitter (when locked)	t <sub>PJ</sub>	-	-	-10	-	10	ns	
Internal Slow CR oscillation frequency	F <sub>CRS</sub>	-	-	50	100	150	kHz	
Internal Fast CR oscillation frequency	F <sub>CRF</sub>	-	-	2.40	4.00	5.61-	MHz	Before trim
				3.20	4.00	4.81	MHz	After trim

#### Notes:

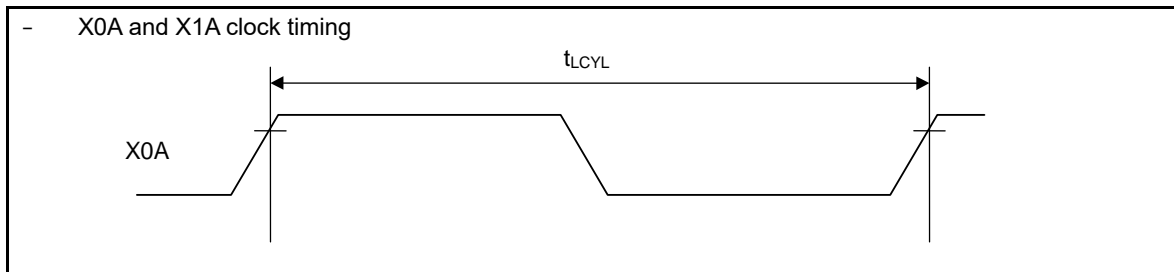
- The maximum/minimum values have been standardized with the main clock and PLL clock in use.
- Jitter of source oscillator must be smaller than 300 ppm.
- Enough evaluation and adjustment are recommended using oscillator on your system board.



## 9.1.4.2 Sub Clock Timing

 (T<sub>A</sub>: Recommended operating conditions, V<sub>CC5</sub> = 5.0 V ±10 %, V<sub>SS</sub> = DV<sub>SS</sub> = AV<sub>SS</sub> = 0.0 V)

Parameter	Symbol	Pin Name	Conditions	Value			Unit	Remarks
				Min	Typ	Max		
Source oscillation clock frequency	F <sub>CL</sub>	X0A, X1A	-	-	32.768	-	kHz	
Source oscillation clock cycle time	t <sub>LCYL</sub>	X0A, X1A	-	-	30.52	-	μs	





### 9.1.4.3 Internal Clock Timing (S6J3310)

- This chapter shows the TARGET characteristics for internal clock timing at the current stage.
- In the column symbol, same clock names as described in CHAPTER 5: CLOCK SYSTEM of *Traveo™ Platform Hardware Manual* are used.
- Corresponding functions for these clocks are described in CHAPTER 5: CLOCK CONFIGURATION of *S6J3300 Series Hardware Manual*.

(TA: Recommended operating conditions, V<sub>CC5</sub> = 5.0 V ±10 %, V<sub>CC12</sub> = 1.15 V ± 0.06 V, V<sub>SS</sub> = 0.0 V)

Parameter	Symbol	Value			Unit	Remarks
		Max *1	Max *2	Max *3		
Internal clock frequency	F <sub>SSCG0</sub>	480	400	360	MHz	SSCG0 output clock *4
	F <sub>SSCG1</sub>	400	400	400	MHz	SSCG1 output clock *4
	F <sub>SSCG2</sub>	320	320	320	MHz	SSCG2 output clock *4
	F <sub>SSCG3</sub>	400	400	400	MHz	SSCG3 output clock *4
	F <sub>PLL0</sub>	480	400	360	MHz	PLL0 output clock *4
	F <sub>PLL1</sub>	400	400	400	MHz	PLL1 output clock *4
	F <sub>PLL2</sub>	400	400	400	MHz	PLL2 output clock *4
	F <sub>PLL3</sub>	480	480	480	MHz	PLL3 output clock *4
	F <sub>CLK_CPU0</sub>	240	200	180	MHz	
	F <sub>CLK_SHE</sub>	240	200	180	MHz	
	F <sub>CLK_FCLK</sub>	80	66.7	90	MHz	
	F <sub>CLK_ATB</sub>	120	100	90	MHz	
	F <sub>CLK_DBG</sub>	120	100	90	MHz	
	F <sub>CLK_HPM</sub>	120	200	180	MHz	
	F <sub>CLK_HPM2</sub>	60	100	90	MHz	
	F <sub>CLK_DMA</sub>	120	200	180	MHz	
	F <sub>CLK_MEMC</sub>	120	200	180	MHz	
	F <sub>CLK_EXTBUS</sub>	40	40	30	MHz	
	F <sub>CLK_SYSC1</sub>	40	40	60	MHz	
	F <sub>CLK_HAPP0A0</sub>	40	40	30	MHz	Unused
	F <sub>CLK_HAPP0A1</sub>	40	40	30	MHz	Unused
	F <sub>CLK_HAPP1B0</sub>	80	50	60	MHz	
	F <sub>CLK_HAPP1B1</sub>	40	50	30	MHz	Unused
	F <sub>CLK_LLPBM</sub>	240	200	180	MHz	
	F <sub>CLK_LLPBM2</sub>	120	100	90	MHz	
	F <sub>CLK_LCP</sub>	80	50	60	MHz	
	F <sub>CLK_LCP0</sub>	40	40	30	MHz	
	F <sub>CLK_LCP0A</sub>	80	66.7	60	MHz	
	F <sub>CLK_LCP1</sub>	40	40	30	MHz	Unused
	F <sub>CLK_LCP1A</sub>	80	66.7	60	MHz	
	F <sub>CLK_LAPP0</sub>	40	40	30	MHz	Unused
	F <sub>CLK_LAPP0A</sub>	40	40	30	MHz	Unused
	F <sub>CLK_LAPP1</sub>	40	40	30	MHz	Unused
	F <sub>CLK_LAPP1A</sub>	40	40	30	MHz	Unused
	F <sub>CLK_TRC</sub>	100	100	100	MHz	
	F <sub>CLK_CD1</sub>	200	200	200	MHz	
	F <sub>CLK_CD1A0</sub>	100	100	100	MHz	Unused
	F <sub>CLK_CD1A1</sub>	100	100	100	MHz	Unused
	F <sub>CLK_CD1B0</sub>	100	100	100	MHz	Unused
	F <sub>CLK_CD1B1</sub>	100	100	100	MHz	Unused
	F <sub>CLK_CD2</sub>	200	200	200	MHz	Unused
	F <sub>CLK_CD2A0</sub>	200	200	200	MHz	
	F <sub>CLK_CD2A1</sub>	200	200	200	MHz	Unused
F <sub>CLK_CD2B0</sub>	200	200	200	MHz	Unused	
F <sub>CLK_CD2B1</sub>	200	200	200	MHz	Unused	
F <sub>CLK_CD3</sub>	80	80	80	MHz	Unused	
F <sub>CLK_CD3A0</sub>	80	80	80	MHz		
F <sub>CLK_CD3A1</sub>	80	80	80	MHz	Unused	

Parameter	Symbol	Value			Unit	Remarks
		Max *1	Max *2	Max *3		
Internal clock frequency	FCLK_CD3B0	80	80	80	MHz	Unused
	FCLK_CD3B1	80	80	80	MHz	Unused
	FCLK_CD4	200	200	200	MHz	
	FCLK_CD4A0	200	200	200	MHz	Unused
	FCLK_CD4A1	200	200	200	MHz	Unused
	FCLK_CD4B0	200	200	200	MHz	Unused
	FCLK_CD4B1	200	200	200	MHz	Unused
	FCLK_CD5	240	240	240	MHz	
	FCLK_CD5A0	120	120	120	MHz	
	FCLK_CD5A1	120	120	120	MHz	Unused
	FCLK_CD5B0	60	60	60	MHz	
	FCLK_CD5B1	60	60	60	MHz	Unused
	FCLK_HSSPI	200	200	200	MHz	
	FCLK_SYSC0H	80	66.7	60	MHz	
	FCLK_COMH	80	66.7	60	MHz	
	FCLK_RAM0H	80	66.7	60	MHz	
	FCLK_RAM1H	80	66.7	60	MHz	
	FCLK_SYSC0P	80	66.7	60	MHz	
FCLK_COMP	80	66.7	60	MHz		

\*1: Target maximum clock frequencies when CPU clock = 240MHz

\*2: Target maximum clock frequencies when CPU clock = 200MHz

\*3: Target maximum clock frequencies when CPU clock = 180MHz

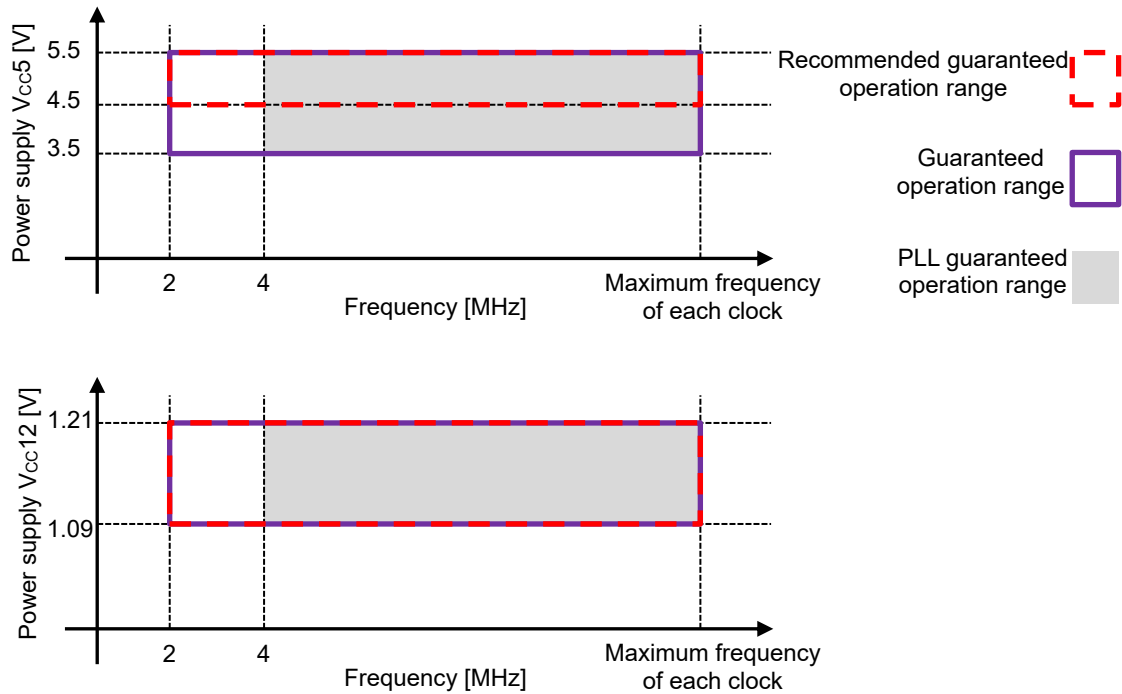
\*4: The PLLx/SSCGx cannot set under 200MHz.

- Note that Ta = 125 condition is not supported in this product type.

When using SSCG\_PLL output for these internal clock, the MAX value of frequency has the following restrictions.

- On the presumption that the modulation mode of SSCG\_PLL is used with down spread, the MAX value of the frequency is standardized.
- This means that MAX value of frequency is the maximum value when SSCG\_PLL was modulated.
- "Unused" means a clock source which doesn't have any supply destinations. Configure it as disable with performing at the lower clock frequency than the described maximum.

- Operation assurance range  
Relationship between the internal clock frequency and supply voltage

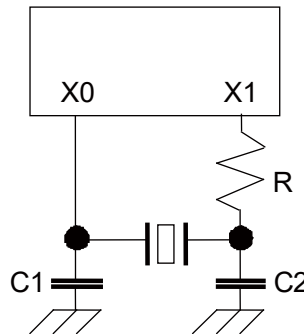


Note: CPU will be reset, when the power supply voltage is equal to or less than LVD setting voltage.

- Relationship between the oscillation clock frequency and internal clock frequency

		Internal Operation Clock Frequency							
		Main Clock	PLL Clock						
			Multiplied by 1	Multiplied by 2	...	Multiplied by 15	Multiplied by 30	Multiplied by 40	Multiplied by 60
Oscillation clock frequency [MHz]	4	2	4	8	...	60	120	160	240
	8	4	8	16	...	120	240		
	16	8	16	32	...	240			

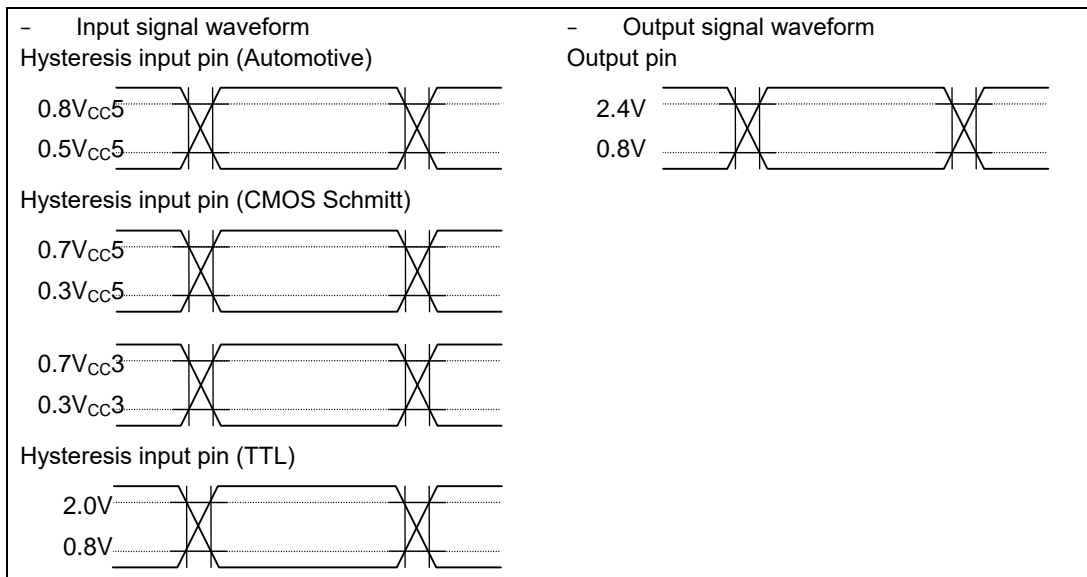
- Oscillation circuit example



Note:

For the configuration of an oscillation circuit, request the oscillator manufacturer to perform a circuit matching evaluation before starting design.

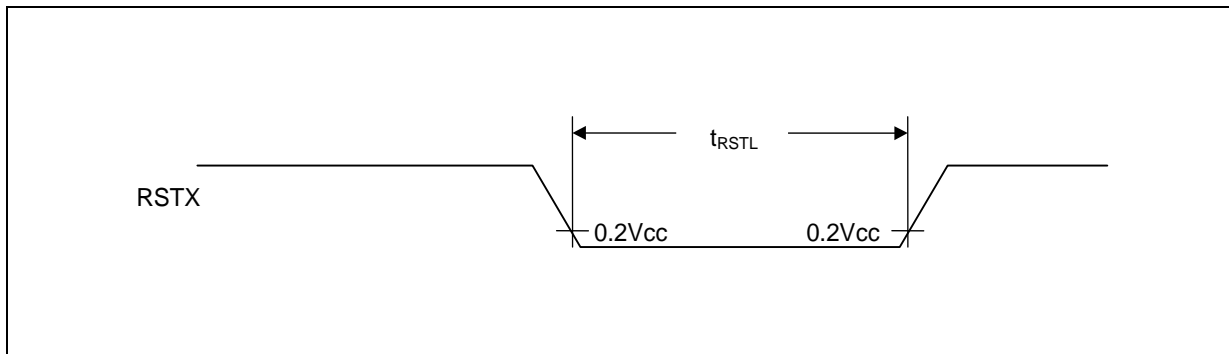
AC characteristics are specified by the following measurement reference voltage values.



## 9.1.4.4 Reset Input

 (T<sub>A</sub>: Recommended operating conditions, V<sub>CC5</sub> = 5.0 V ±10 %, V<sub>SS</sub> = 0.0 V)

Parameter	Symbol	Pin Name	Conditions	Value		Unit	Remarks
				Min	Max		
Reset input time	t <sub>RSTL</sub>	RSTX	-	10	-	μs	
Width for reset input removal				1	-	μs	



## 9.1.4.5 Power-on Conditions

(T<sub>A</sub>: Recommended operating conditions, V<sub>SS</sub> = 0.0 V)

Parameter	Symbol	Pin Name	Conditions	Value			Unit	Remarks
				Min	Typ	Max		
Level detection voltage	-	VCC5	-	2.2	2.4	2.6	V	
Level detection hysteresis width	-	VCC5	-	-	100	-	mV	
Level detection time	-	-	-	-	-	40	μs	*1
Power off time	t <sub>OFF</sub>	VCC5	-	100	-	-	μs	*2
Power ramp rate	dV/dt	VCC5	VCC5: 1.5 V to 2.6 V	-	-	1	V/μs	*3
Maximum ramp rate guaranteed to not generate power-on reset	dV/dt	VCC5	VCC5: Between 2.4 V and 4.5 V	-	-	50	mV/μs	*4

\*1: This specification is at 1 V/μs of power ramp rate.

\*2: VCC5 must be held below 1.5 V for a minimum period of t<sub>OFF</sub>.

\*3: Power ramp rate must be 1 V/us or less from 1.5 V to 2.6 V.

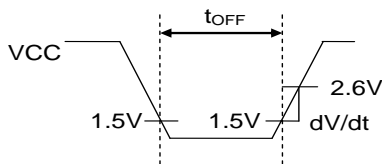
Power-on can detect by satisfying power ramp rate when power off time is satisfied.

\*4: This specification is specified the power supply fluctuation after power on detection. When VCC5 voltage is between 2.4 V and 4.5 V, the power supply fluctuation is below 50 mV/us, the detection of power-on is suppressed. The power-on does not detect in any power fluctuation between 4.5 V and 5.5 V.

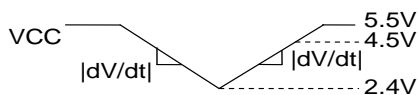
### Notes:

When using S6J3310/20/30/40, \*2 and \*3 must be satisfied. When neither \*2 nor \*3 can be satisfied, assert external reset (RSTX) at power up and any brownout event.

#### • Power off time, Power ramp rate



#### • Maximum ramp rate guaranteed to not generate power-on reset



### 9.1.4.6 Multi-Function Serial

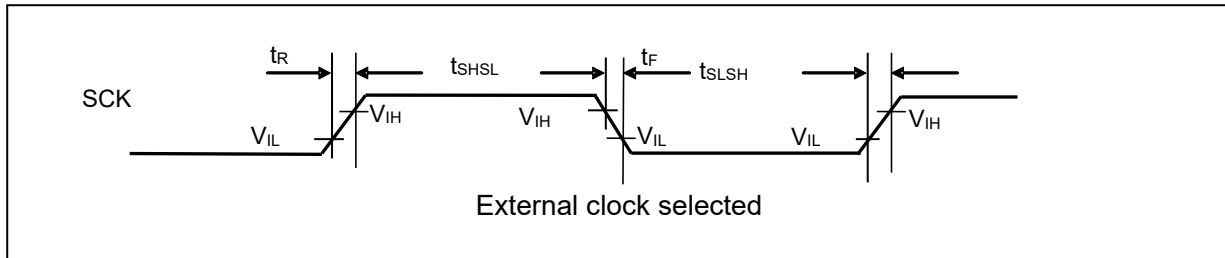
UART (asynchronous serial interface) timing (SMR:MD2-0 = 0b000, 0b001)

#### (1) External Clock Selected (BGR:EXT = 1)

(T<sub>A</sub>: Recommended operating conditions, V<sub>CC3</sub> = 3.3 V ± 0.3 V, V<sub>CC5</sub> = DV<sub>CC</sub> = 5.0 V ± 10 % / 3.3 V ± 0.3 V, V<sub>CC53</sub> = 5.0 V ± 10 % / 3.3 V ± 0.3 V, V<sub>SS</sub> = DV<sub>SS</sub> = 0.0 V, V<sub>CC12</sub> = 1.15 V ± 0.06 V)

Parameter	Symbol	Pin Name	Conditions	Value		Unit	Remarks
				Min	Max		
Serial clock "L" pulse width	t <sub>SLSH</sub>	SCK0 to SCK4, SCK8 to SCK12	-	t <sub>CLK_LCPnA</sub> *1 +10	-	ns	
		SCK16 to SCK17		t <sub>CLK_COMP</sub> +10	-	ns	
Serial clock "H" pulse width	t <sub>SHSL</sub>	SCK0 to SCK4, SCK8 to SCK12		t <sub>CLK_LCPnA</sub> *1 +10	-	ns	
		SCK16 to SCK17		t <sub>CLK_COMP</sub> +10	-	ns	
SCK falling time	t <sub>F</sub>	SCK0 to SCK4, SCK8 to SCK12,		-	5	ns	
SCK rising time	t <sub>R</sub>	SCK16 to SCK17		-	5	ns	

\*1: n = 0:ch.0 to ch.4, n = 1:ch.8 to ch.12



CSIO timing (SMR:MD2-0 = 0b010)

**(1) Normal Synchronous Transfer (SCR:SPI = 0) and Mark Level "H" of Serial Clock Output (SMR:SCINV = 0)**

(TA: Recommended operating conditions, Vcc3 = 3.3 V ± 0.3 V, Vcc5 = DVcc = 5.0 V ± 10 % / 3.3 V ± 0.3 V, Vcc53 = 5.0 V ± 10 % / 3.3 V ± 0.3 V, Vss = DVss = 0.0 V, Vcc12 = 1.15 V ± 0.06 V)

Parameter	Symbol	Pin Name	Conditions	Value		Unit	Remarks	
				Min	Max			
Serial clock cycle time	t <sub>SCYC</sub>	SCK0, SCK1, SCK2_1, SCK3_1, SCK4, SCK8 to SCK12	Master Mode (CL = 20 pF, I <sub>OL</sub> = -5 mA, I <sub>OH</sub> = 5 mA)	8t <sub>CLK_LCPnA</sub> *1	-	ns	-	
		SCK16 to SCK17		8t <sub>CLK_COMP</sub>	-	ns		
SCK ↓ → SOT delay time	t <sub>SLOVI</sub>	SCK0, SCK1, SCK2_1, SCK3_1, SCK4, SCK8 to SCK12, SCK16 to SCK17 SOT0, SOT1, SOT2_1, SOT3_1, SOT4, SOT8 to SOT12, SOT16 to SOT17		-30	+30	ns		
Valid SIN → SCK ↑ setup time	t <sub>IVSHI</sub>	SCK0, SCK1, SCK2_1, SCK3_1, SCK4, SCK8 to SCK12, SCK16 to SCK17		40	-	ns		
SCK ↑ → Valid SIN hold time	t <sub>SHIXI</sub>	SIN0, SIN1, SIN2_1, SIN3_1, SIN4, SIN8 to SIN12, SIN16 to SIN17		0	-	ns		
Serial clock cycle time	t <sub>SCYC</sub>	SCK2_0, SCK3_0		Master Mode (CL = 20 pF, I <sub>OL</sub> = -10 mA, I <sub>OH</sub> = 10 mA)	2t <sub>CLK_LCPnA</sub> *1	-	ns	-
SCK ↓ → SOT delay time	t <sub>SLOVI</sub>	SCK2_0, SCK3_0, SOT2_0, SOT3_0			-7.5	+7.5	ns	
Valid SIN → SCK ↑ setup time	t <sub>IVSHI</sub>	SCK2_0, SCK3_0, SIN2_0, SIN3_0			10	-	ns	
SCK ↑ → Valid SIN hold time	t <sub>SHIXI</sub>				0	-	ns	

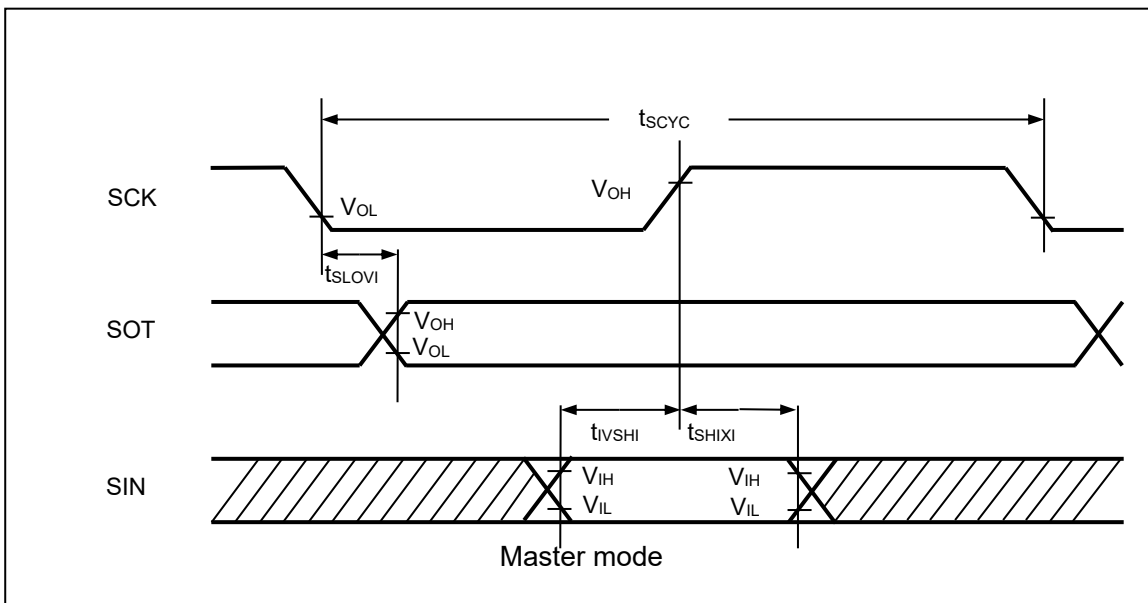


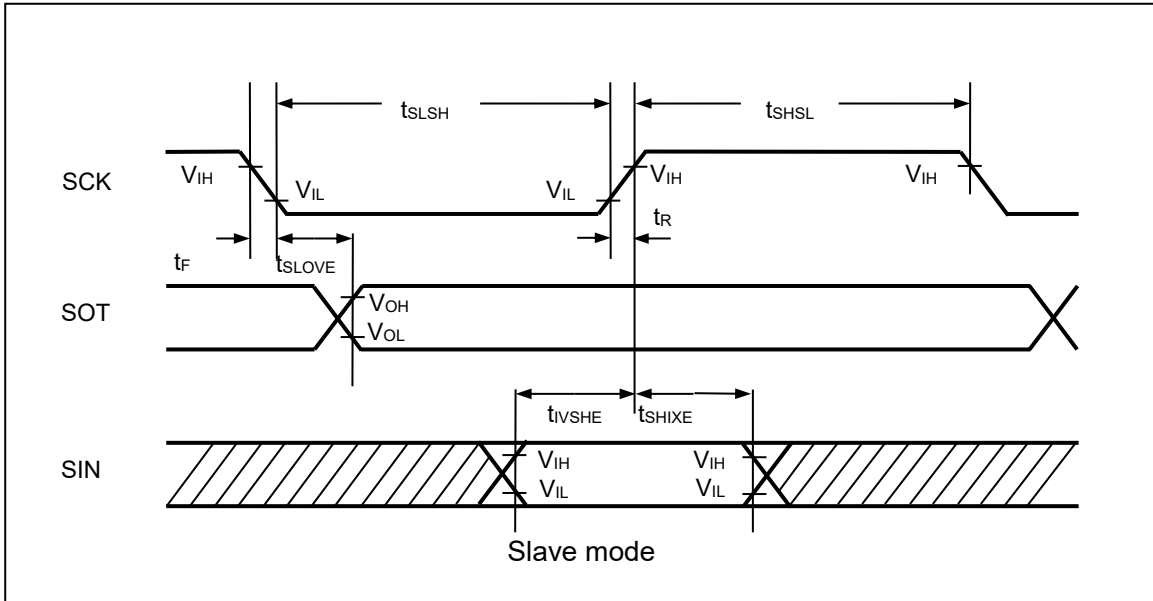
Parameter	Symbol	Pin Name	Conditions	Value		Unit	Remarks
				Min	Max		
Serial clock "H" pulse width	$t_{SHSL}$	SCK0 to SCK4, SCK8 to SCK12	Slave Mode (CL = 20 pF, I <sub>OL</sub> = -5 mA, I <sub>OH</sub> = 5 mA)	$4t_{CLK\_LCPnA}^{*1}$	-	ns	-
		SCK16 to SCK17		$4t_{CLK\_COMP}$	-	ns	
Serial clock "L" pulse width	$t_{SLSH}$	SCK0 to SCK4, SCK8 to SCK12		$4t_{CLK\_LCPnA}^{*1}$	-	ns	
		SCK16 to SCK17		$4t_{CLK\_COMP}$	-	ns	
SCK ↓ → SOT delay time	$t_{SLOVE}$	SCK0 to SCK4, SCK8 to SCK12, SCK16 to SCK17 SOT0 to SOT4, SOT8 to SOT12, SOT16 to SOT17		-	40	ns	
Valid SIN → SCK ↑ setup time	$t_{VSHSE}$	SCK0 to SCK4, SCK8 to SCK12, SCK16 to SCK17		10	-	ns	
SCK ↑ → Valid SIN hold time	$t_{SHIXE}$	SIN0 to SIN4, SIN8 to SIN12, SIN16 to SIN17		10	-	ns	
SCK falling time	$t_F$	SCK0 to SCK4, SCK8 to SCK12, SCK16 to SCK17		-	5	ns	
SCK rising time	$t_R$	SCK0 to SCK4, SCK8 to SCK12, SCK16 to SCK17	-	5	ns		

\*1: n = 0:ch.0 to ch.4, n = 1:ch.8 to ch.12

**Notes:**

- This table provides the alternate current standard for CLK synchronous mode.
- CL is the load capability value connected to the pin at the test time.
- The maximum baud rate is limited by the internal operating clock used and other parameters. For details, see the Traveo™ Platform Hardware Manual.





### (2) Normal Synchronous Transfer (SCR:SPI = 0) and Mark Level "L" of Serial Clock Output (SMR:SCINV = 1)

(TA: Recommended operating conditions, Vcc3 = 3.3 V ± 0.3 V, Vcc5 = DVcc = 5.0 V ± 10% / 3.3 V ± 0.3 V, Vcc53 = 5.0 V ± 10% / 3.3 V ± 0.3 V, Vss = DVss = 0.0 V, Vcc12 = 1.15 V ± 0.06 V)

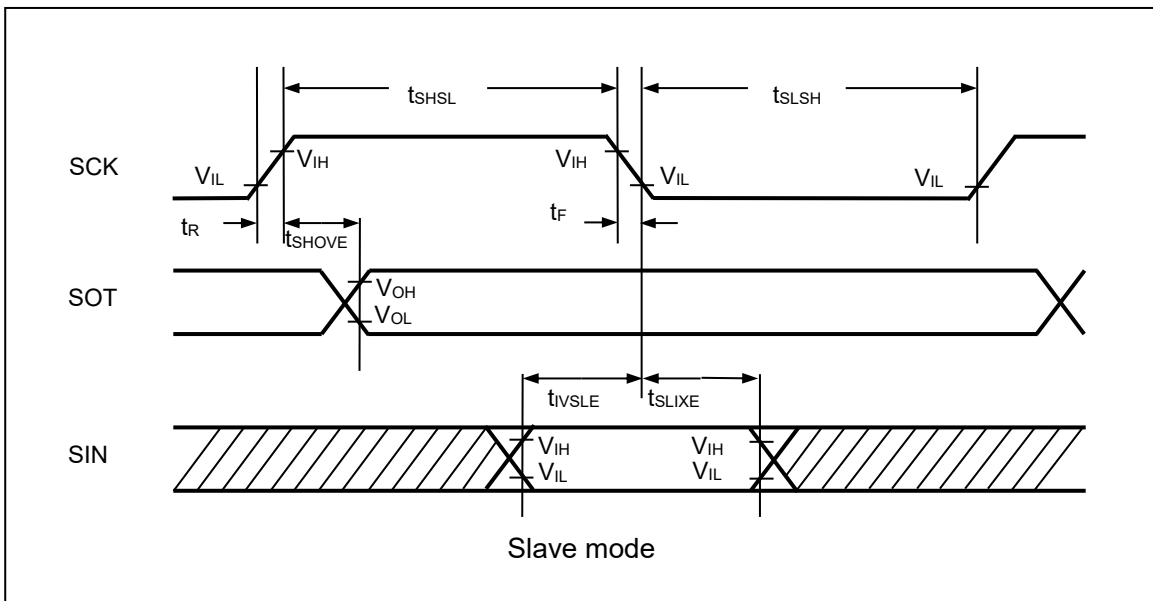
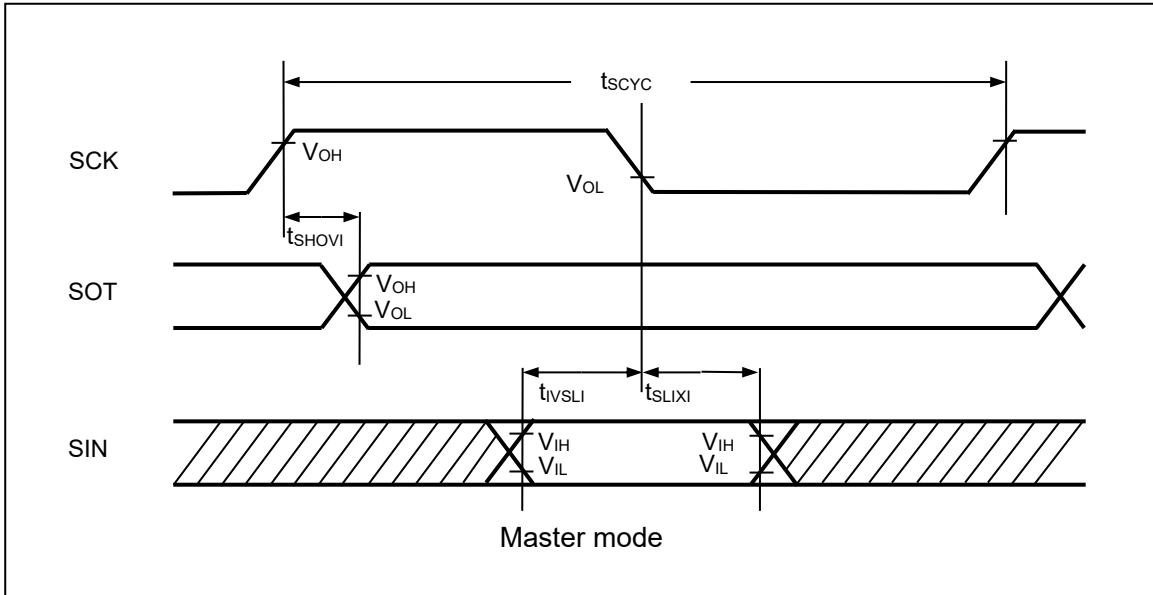
Parameter	Symbol	Pin Name	Conditions	Value		Unit	Remarks
				Min	Max		
Serial clock cycle time	t <sub>SCYC</sub>	SCK0, SCK1, SCK2_1, SCK3_1, SCK4, SCK8 to SCK12	Master Mode (CL = 20 pF, I <sub>OL</sub> = -5 mA, I <sub>OH</sub> = 5 mA)	8t <sub>CLK_LCPnA</sub> *1	-	ns	
		SCK16 to SCK17		8t <sub>CLK_COMP</sub>	-	ns	
SCK ↑ → SOT delay time	t <sub>SHOVI</sub>	SCK0, SCK1, SCK2_1, SCK3_1, SCK4, SCK8 to SCK12, SCK16 to SCK17 SOT0, SOT1, SOT2_1, SOT3_1, SOT4, SOT8 to SOT12, SOT16 to SOT17		-30	+30	ns	
Valid SIN → SCK ↓ setup time	t <sub>IVSLI</sub>	SCK0, SCK1, SCK2_1, SCK3_1, SCK4, SCK8 to SCK12, SCK16 to SCK17		40	-	ns	
SCK ↓ → Valid SIN hold time	t <sub>SLIXI</sub>	SIN0, SIN1, SIN2_1, SIN3_1, SIN4, SIN8 to SIN12, SIN16 to SIN17	0	-	ns		

Parameter	Symbol	Pin Name	Conditions	Value		Unit	Remarks
				Min	Max		
Serial clock cycle time	t <sub>SCYC</sub>	SCK2_0, SCK3_0	Master Mode (CL = 20 pF, I <sub>OL</sub> = -10 mA, I <sub>OH</sub> = 10 mA)	2t <sub>CLK_LCPnA</sub> *1	-	ns	
SCK ↓ → SOT delay time	t <sub>SHOVI</sub>	SCK2_0, SCK3_0, SOT2_0, SOT3_0		-7.5	+7.5	ns	
Valid SIN → SCK ↑ setup time	t <sub>IVSLI</sub>	SCK2_0, SCK3_0, SIN2_0, SIN3_0		10	-	ns	
SCK ↑ → Valid SIN hold time	t <sub>SLIXI</sub>			0	-	ns	
Serial clock "H" pulse width	t <sub>SHSL</sub>	SCK0 to SCK4, SCK8 to SCK12	Slave Mode (CL = 20 pF, I <sub>OL</sub> = -5 mA, I <sub>OH</sub> = 5 mA)	4t <sub>CLK_LCPnA</sub> *1	-	ns	
		SCK16 to SCK17		4t <sub>CLK_COMP</sub>	-	ns	
Serial clock "L" pulse width	t <sub>LSLH</sub>	SCK0 to SCK4, SCK8 to SCK12		4t <sub>CLK_LCPnA</sub> *1	-	ns	
		SCK16 to SCK17		4t <sub>CLK_COMP</sub>	-	ns	
SCK ↑ → SOT delay time	t <sub>SHOVE</sub>	SCK0 to SCK4, SCK8 to SCK12, SCK16 to SCK17 SOT0 to SOT4, SOT8 to SOT12, SOT16 to SOT17		-	40	ns	
Valid SIN → SCK ↓ setup time	t <sub>IVSLE</sub>	SCK0 to SCK4, SCK8 to SCK12, SCK16 to SCK17 SIN0 to SIN4, SIN8 to SIN12, SIN16 to SIN17		10	-	ns	
SCK ↓ → Valid SIN hold time	t <sub>SLIXE</sub>			10	-	ns	
SCK falling time	t <sub>F</sub>	SCK0 to SCK4, SCK8 to SCK12, SCK16 to SCK17		-	5	ns	
SCK rising time	t <sub>R</sub>	SCK0 to SCK4, SCK8 to SCK12, SCK16 to SCK17	-	5	ns		

\*1: n = 0:ch.0 to ch.4, n = 1:ch.8 to ch.12

**Notes:**

- This table provides the alternate current standard for CLK synchronous mode.
- CL is the load capability value connected to the pin at the test time.
- The maximum baud rate is limited by the internal operating clock used and other parameters. For details, see the Traveo™ Platform Hardware Manual.



**(3) SPI Supported (SCR:SPI = 1), and Mark Level "H" of Serial Clock Output (SMR:SCINV = 0)**

(TA: Recommended operating conditions, Vcc3 = 3.3 V ± 0.3 V, Vcc5 = DVcc = 5.0 V ± 10 % / 3.3 V ± 0.3 V, Vcc53 = 5.0 V ± 10 % / 3.3 V ± 0.3 V, Vss = DVss = 0.0 V, Vcc12 = 1.15 V ± 0.06 V)

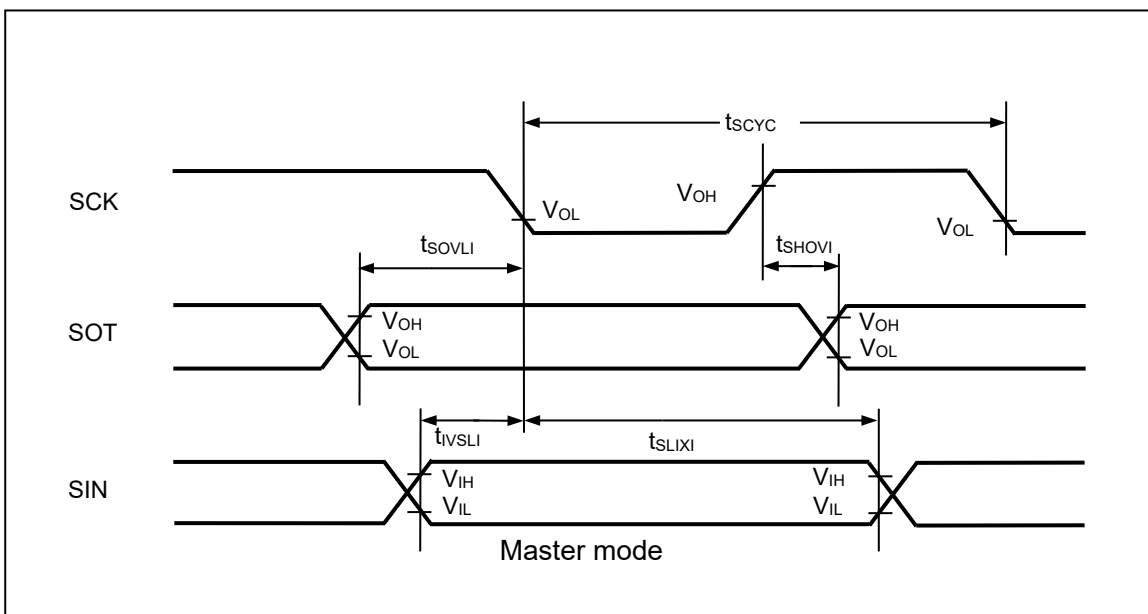
Parameter	Symbol	Pin Name	Conditions	Value		Unit	Remarks	
				Min	Max			
Serial clock cycle time	t <sub>SCYC</sub>	SCK0, SCK1, SCK2_1, SCK3_1, SCK4, SCK8 to SCK12	Master Mode (CL = 20 pF, I <sub>OL</sub> = -5 mA, I <sub>OH</sub> = 5 mA)	8t <sub>CLK_LCPnA</sub> *1	-	ns	-	
		SCK16 to SCK17		8t <sub>CLK_COMP</sub>	-	ns	-	
SCK ↑ → SOT delay time	t <sub>SHOVI</sub>	SCK0, SCK1, SCK2_1, SCK3_1, SCK4, SCK8 to SCK12, SCK16 to SCK17 SOT0, SOT1, SOT2_1, SOT3_1, SOT4, SOT8 to SOT12, SOT16 to SOT17		-30	+30	ns	-	
Valid SIN → SCK ↓ setup time	t <sub>IVSLI</sub>	SCK0, SCK1, SCK2_1, SCK3_1, SCK4, SCK8 to SCK12, SCK16 to SCK17		40	-	ns	-	
SCK ↓ → Valid SIN hold time	t <sub>SLIXI</sub>	SIN0, SIN1, SIN2_1, SIN3_1, SIN4, SIN8 to SIN12, SIN16 to SIN17		0	-	ns	-	
SOT → SCK ↓ delay time	t <sub>SOVLI</sub>	SCK0, SCK1, SCK2_1, SCK3_1, SCK4, SCK8 to SCK12, SCK16 to SCK17 SOT0, SOT1, SOT2_1, SOT3_1, SOT4, SOT8 to SOT12, SOT16 to SOT17		4t <sub>CLK_LCPnA</sub> *1 - 30	-	ns	-	
		SCK16 to SCK17 SOT16 to SOT17		4t <sub>CLK_COMP</sub> *1 - 30	-	ns	-	
Serial clock cycle time	t <sub>SCYC</sub>	SCK2_0, SCK3_0		Master Mode (CL = 20 pF, I <sub>OL</sub> = -10 mA, I <sub>OH</sub> = 10 mA)	2t <sub>CLK_LCPnA</sub> *1	-	ns	-
SCK ↑ → SOT delay time	t <sub>SHOVI</sub>	SCK2_0, SCK3_0, SOT2_0, SOT3_0			-7.5	+7.5	ns	-
Valid SIN → SCK ↑ setup time	t <sub>IVSHI</sub>	SCK2_0, SCK3_0, SIN2_0, SIN3_0			10	-	ns	-
SCK ↑ → Valid SIN hold time	t <sub>SHIXI</sub>		0		-	ns	-	
SOT → SCK ↓ delay time	t <sub>SOVLI</sub>	SCK2_0, SCK3_0, SOT2_0, SOT3_0	t <sub>CLK_LCPnA</sub> *1 - 7.5		-	ns	-	

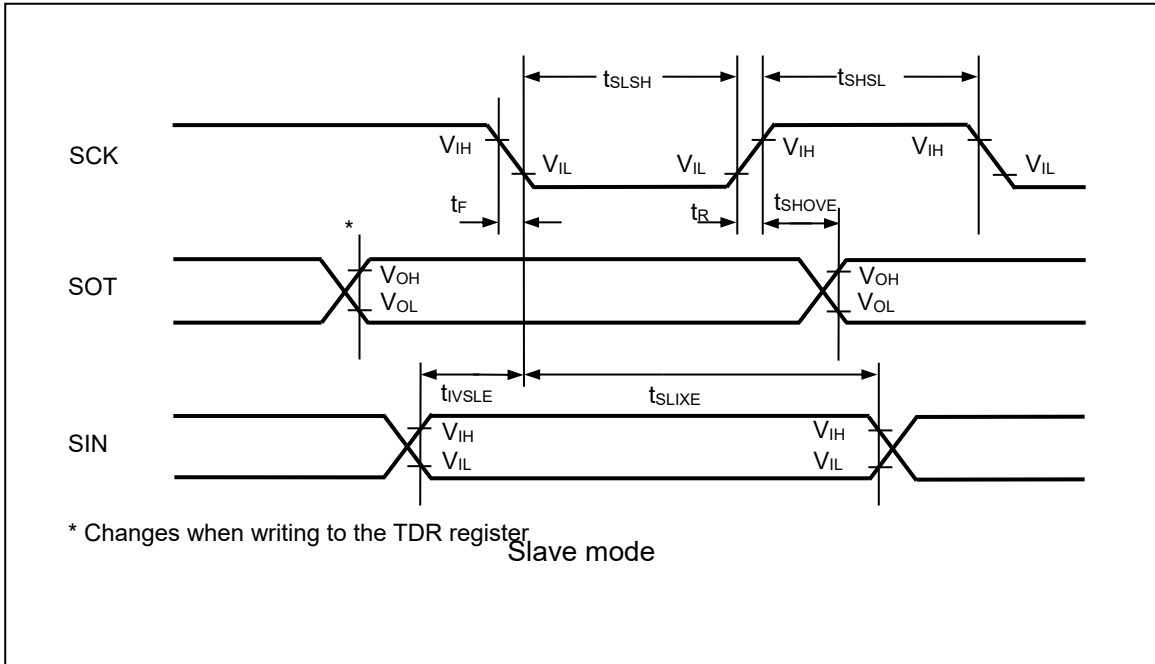
Parameter	Symbol	Pin Name	Conditions	Value		Unit	Remarks
				Min	Max		
Serial clock "H" pulse width	$t_{SHSL}$	SCK0 to SCK4, SCK8 to SCK12	Slave Mode (CL = 20 pF, $I_{OL} = -5$ mA, $I_{OH} = 5$ mA)	$4t_{CLK\_LCPnA}^{*1}$	-	ns	
		SCK16 to SCK17		$4t_{CLK\_COMP}$	-	ns	
Serial clock "L" pulse width	$t_{SLSH}$	SCK0 to SCK4, SCK8 to SCK12		$4t_{CLK\_LCPnA}^{*1}$	-	ns	
		SCK16 to SCK17		$4t_{CLK\_COMP}$	-	ns	
SCK $\uparrow \rightarrow$ SOT delay time	$t_{SHOVE}$	SCK0 to SCK4, SCK8 to SCK12, SOT0 to SOT4, SOT8 to SOT12, SOT16 to SOT17		-	40	ns	
Valid SIN $\rightarrow$ SCK $\downarrow$ setup time	$t_{IVSLE}$	SCK0 to SCK4, SCK8 to SCK12, SCK16 to SCK17		10	-	ns	
SCK $\downarrow \rightarrow$ Valid SIN hold time	$t_{SLIXE}$	SIN0 to SIN4, SIN8 to SIN12, SIN16 to SIN17		10	-	ns	
SCK falling time	$t_F$	SCK0 to SCK4, SCK8 to SCK12 SCK16 to SCK17	-	5	ns		
SCK rising time	$t_R$	SCK0 to SCK4, SCK8 to SCK12 SCK16 to SCK17	-	5	ns		

\*1: n = 0:ch.0 to ch.4, n = 1:ch.8 to ch.12

**Notes:**

- This table provides the alternate current standard for CLK synchronous mode.
- CL is the load capability value connected to the pin at the test time.
- The maximum baud rate is limited by the internal operating clock used and other parameters. For details, see the Traveo™ Platform Hardware Manual.







### (4) SPI Supported (SCR:SPI = 1), and Mark Level "L" of Serial Clock Output (SMR:SCINV = 1)

(TA: Recommended operating conditions, Vcc3 = 3.3 V ± 0.3 V, Vcc5 = DVcc = 5.0 V ± 10 % / 3.3 V ± 0.3 V, Vcc53 = 5.0 V ± 10 % / 3.3 V ± 0.3 V, Vss = DVss = 0.0 V, Vcc12 = 1.15 V ± 0.06 V)

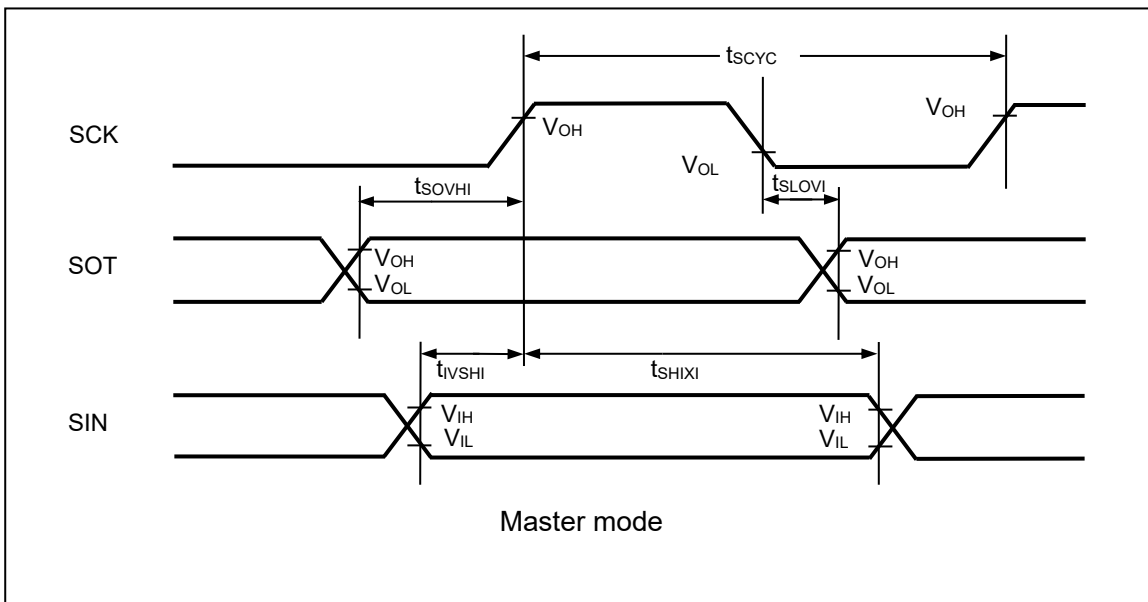
Parameter	Symbol	Pin Name	Conditions	Value		Unit	Remarks	
				Min	Max			
Serial clock cycle time	tscyc	SCK0, SCK1, SCK2_1, SCK3_1, SCK4, SCK8 to SCK12	Master Mode (CL = 20 pF, IOL = -5 mA, IOH = 5 mA)	8tCLK_LCPnA*1	-	ns	-	
		SCK16 to SCK17		8tCLK_COMP	-	ns		
SCK ↓ -> SOT delay time	tsLOVI	SCK0, SCK1, SCK2_1, SCK3_1, SCK4, SCK8 to SCK12, SCK16 to SCK17 SOT0, SOT1, SOT2_1, SOT3_1, SOT4, SOT8 to SOT12, SOT16 to SOT17		-30	+30	ns		
Valid SIN -> SCK ↑ setup time	tIVSHI	SCK0, SCK1, SCK2_1, SCK3_1, SCK4, SCK8 to SCK12, SCK16 to SCK17		40	-	ns		
SCK ↑ -> Valid SIN hold time	tSHIXI	SIN0, SIN1, SIN2_1, SIN3_1, SIN4, SIN8 to SIN12, SIN16 to SIN17		0	-	ns		
SOT -> SCK ↑ delay time	tSOVHI	SCK0, SCK1, SCK2_1, SCK3_1, SCK4, SCK8 to SCK12, SCK16 to SCK17 SOT0, SOT1, SOT2_1, SOT3_1, SOT4, SOT8 to SOT12, SOT16 to SOT17		4tCLK_LCPnA*1 - 30	-	ns		
		SCK16 to SCK17 SOT16 to SOT17		4tCLK_COMP - 30	-	ns		
Serial clock cycle time	tscyc	SCK2_0, SCK3_0		Master Mode (CL = 20 pF, IOL = -10 mA, IOH = 10 mA)	2tCLK_LCPnA*1	-	ns	-
SCK ↓ -> SOT delay time	tsLOVI	SCK2_0, SCK3_0, SOT2_0, SOT3_0			-7.5	+7.5	ns	
Valid SIN -> SCK ↑ setup time	tIVSHI	SCK2_0, SCK3_0, SIN2_0, SIN3_0			10	-	ns	
SCK ↑ -> Valid SIN hold time	tSHIXI		0		-	ns		
SOT -> SCK ↑ delay time	tSOVHI	SCK2_0, SCK3_0, SOT2_0, SOT3_0	tCLK_LCPnA*1 - 7.5		-	ns		

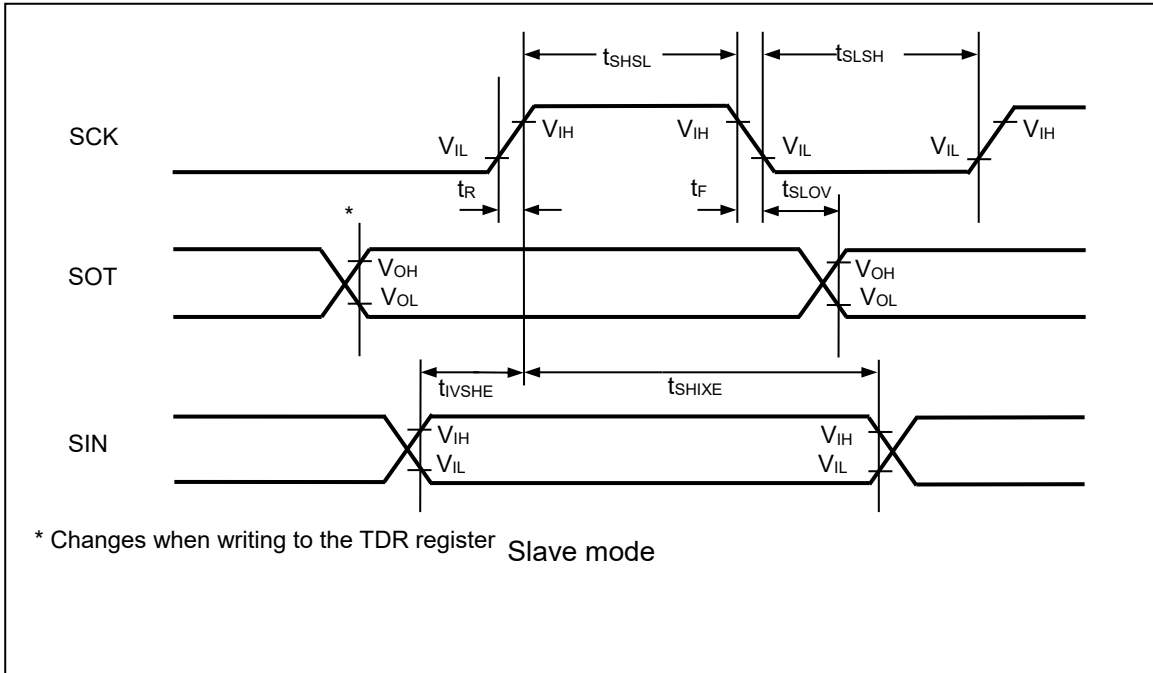
Parameter	Symbol	Pin Name	Conditions	Value		Unit	Remarks
				Min	Max		
Serial clock "H" pulse width	$t_{SHSL}$	SCK0 to SCK4, SCK8 to SCK12	Slave Mode (CL = 20 pF, $I_{OL} = -5$ mA, $I_{OH} = 5$ mA)	$4t_{CLK\_LCPnA}^{*1}$	-	ns	-
		SCK16 to SCK17		$4t_{CLK\_COMP}$	-	ns	
Serial clock "L" pulse width	$t_{SLSH}$	SCK0 to SCK4, SCK8 to SCK12		$4t_{CLK\_LCPnA}^{*1}$	-	ns	
		SCK16 to SCK17		$4t_{CLK\_COMP}$	-	ns	
SCK ↓ -> SOT delay time	$t_{SLOVE}$	SCK0 to SCK4, SCK8 to SCK12, SCK16 to SCK17 SOT0 to SOT4, SOT8 to SOT12, SOT16 to SOT17		-	40	ns	
Valid SIN -> SCK ↑ setup time	$t_{IVSHE}$	SCK0 to SCK4, SCK8 to SCK12, SCK16 to SCK17		10	-	ns	
SCK ↑ -> Valid SIN hold time	$t_{SHIXE}$	SIN0 to SIN4, SIN8 to SIN12, SIN16 to SIN17		10	-	ns	
SCK falling time	$t_F$	SCK0 to SCK4, SCK8 to SCK12 SCK16 to SCK17	-	5	ns		
SCK rising time	$t_R$	SCK0 to SCK4, SCK8 to SCK12 SCK16 to SCK17	-	5	ns		

\*1: n = 0:ch.0 to ch.4, n = 1:ch.8 to ch.12

**Notes:**

- This table provides the alternate current standard for CLK synchronous mode.
- CL is the load capability value connected to the pin at the test time.
- The maximum baud rate is limited by the internal operating clock used and other parameters. For details, see the Traveo™ Platform Hardware Manual.





## (5) Serial Chip Select Used (SCSCR:CSEN = 1)

■ Mark level "H" of serial clock output (SMR, SCSFR:SCINV = 0)

■ Inactive level "H" of serial chip select (SCSCR, SCSFR:CSLVL = 1)

(TA: Recommended operating conditions, Vcc3 = 3.3 V ± 0.3 V, Vcc5 = DVcc = 5.0 V ± 10% / 3.3 V ± 0.3 V, Vcc53 = 5.0 V ± 10% / 3.3 V ± 0.3 V, Vss = DVss = 0.0 V, Vcc12 = 1.15 V ± 0.06 V)

Parameter	Symbol	Pin Name	Conditions	Value		Unit	Remarks
				Min	Max		
SCS ↑ → SCK ↓ setup time	t <sub>CSSI</sub>	SCK0, SCK1, SCK2_1, SCK3_1, SCK4, SCK8 to SCK12, SCK16 to SCK17	Master Mode (CL = 20 pF, I <sub>OL</sub> = -5 mA, I <sub>OH</sub> = 5 mA)	t <sub>CSSU</sub> <sup>*1-15</sup>	-	ns	
SCK ↑ → SCS ↑ hold time	t <sub>CSHI</sub>	SCS0x, SCS1x, SCS2x_1, SCS3x_1, SCS4, SCS8x to SCS12x, SCS16x to SCS17x		t <sub>CSHD</sub> <sup>*2+0</sup>	-	ns	
SCS deselect time	t <sub>CSDI</sub>	SCS0x, SCS1x, SCS2x_1, SCS3x_1, SCS4, SCS8x to SCS12x		t <sub>CSDS</sub> <sup>*3-15</sup> +5t <sub>CLK_LCPnA</sub> <sup>*4</sup>	-	ns	
		SCS16x to SCS17x		t <sub>CSDS</sub> <sup>*3-15</sup> +5t <sub>CLK_COMP</sub>	-	ns	
SCS ↑ → SCK ↓ setup time	t <sub>CSSI</sub>	SCK2_0, SCK3_0, SCS2x_0, SCS3x_0	Master Mode (CL = 20 pF, I <sub>OL</sub> = -10 mA, I <sub>OH</sub> = 10 mA)	t <sub>CSSU</sub> <sup>*1-10</sup>	-	ns	
SCK ↑ → SCS ↑ hold time	t <sub>CSHI</sub>			t <sub>CSHD</sub> <sup>*2+0</sup>	-	ns	
SCS deselect time	t <sub>CSDI</sub>			t <sub>CSDS</sub> <sup>*3-10</sup> +5t <sub>CLK_LCPnA</sub> <sup>*4</sup>	-	ns	
SCS ↓ → SCK ↓ setup time	t <sub>CSSE</sub>	SCK0 to SCK4, SCK8 to SCK12 SCS0x to SCS4x, SCS8x to SCS12x	Slave Mode (CL = 20 pF, I <sub>OL</sub> = -5 mA, I <sub>OH</sub> = 5 mA)	4t <sub>CLK_LCPnA</sub> <sup>*4</sup> +15	-	ns	
		SCK16 to SCK17, SCS16x to SCS17x		4t <sub>CLK_COMP</sub> +15	-	ns	
SCK ↑ → SCS ↑ hold time	t <sub>CSHE</sub>	SCK0 to SCK4, SCK8 to SCK12, SCK16 to SCK17, SCS0x to SCS4x, SCS8x to SCS12x, SCS16x to SCS17x		0	-	ns	
SCS deselect time	t <sub>CSDE</sub>	SCS0x to SCS4x, SCS8x to SCS12x		4t <sub>CLK_LCPnA</sub> <sup>*4</sup> +15	-	ns	
		SCS16x to SCS17x		4t <sub>CLK_COMP</sub> +15	-	ns	
SCS ↓ → SOT delay time	t <sub>DSE</sub>	SCS0x to SCS4x, SCS8x to SCS12x, SCS16x to SCS17x,		-	40	ns	
SCS ↑ → SOT delay time	t <sub>DEE</sub>	SOT0 to SOT4, SOT8 to SOT12, SOT16 to SOT17		0	-	ns	

Parameter	Symbol	Pin Name	Conditions	Value		Unit	Remarks
				Min	Max		
SCK ↓ → SCS ↓ clock switching time	t <sub>SCC</sub>	SCK0, SCK1, SCK2_1, SCK3_1, SCK4, SCK8 to SCK12, SCS0x, SCS1x, SCS2x_1, SCS3x_1, SCS4, SCS8x to SCS12x	Master mode round operation (CL = 20 pF, I <sub>OL</sub> = -5 mA, I <sub>OH</sub> = 5 mA)	4t <sub>CLK_LCPnA</sub> <sup>*4</sup> +0	4t <sub>CLK_LCPnA</sub> <sup>*</sup> 4+15	ns	
		SCK16 to SCK17 SCS16x to SCS17x		4t <sub>CLK_COMP</sub> +0	4t <sub>CLK_COMP</sub> +15	ns	
		SCK2_0, SCK3_0, SCS2x_0, SCS3x_0	Master mode round operation (CL = 20 pF, I <sub>OL</sub> = -10 mA, I <sub>OH</sub> = 10 mA)	4t <sub>CLK_LCPnA</sub> <sup>*4</sup> +0	4t <sub>CLK_LCPnA</sub> <sup>*</sup> 4+10	ns	

\*1: t<sub>CSSU</sub> = SCSTR:CSSU[7:0] x serial chip select timing operating clock

\*2: t<sub>CSDH</sub> = SCSTR:CSDH[7:0] x serial chip select timing operating clock

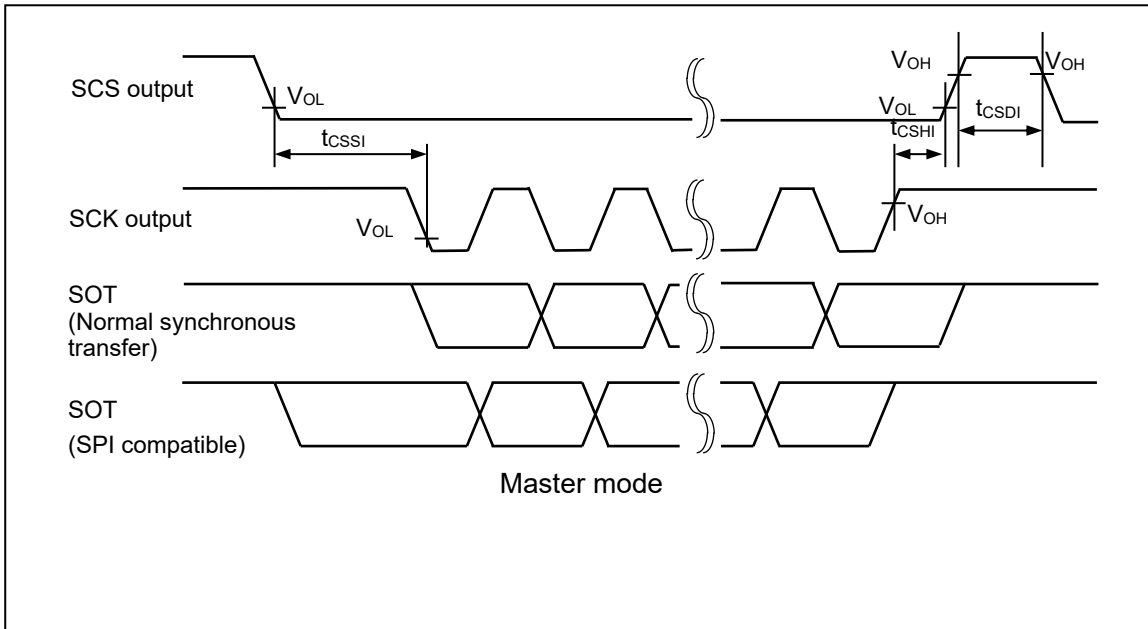
\*3: t<sub>CSDS</sub> = SCSTR:CSDS[15:0] x serial chip select timing operating clock

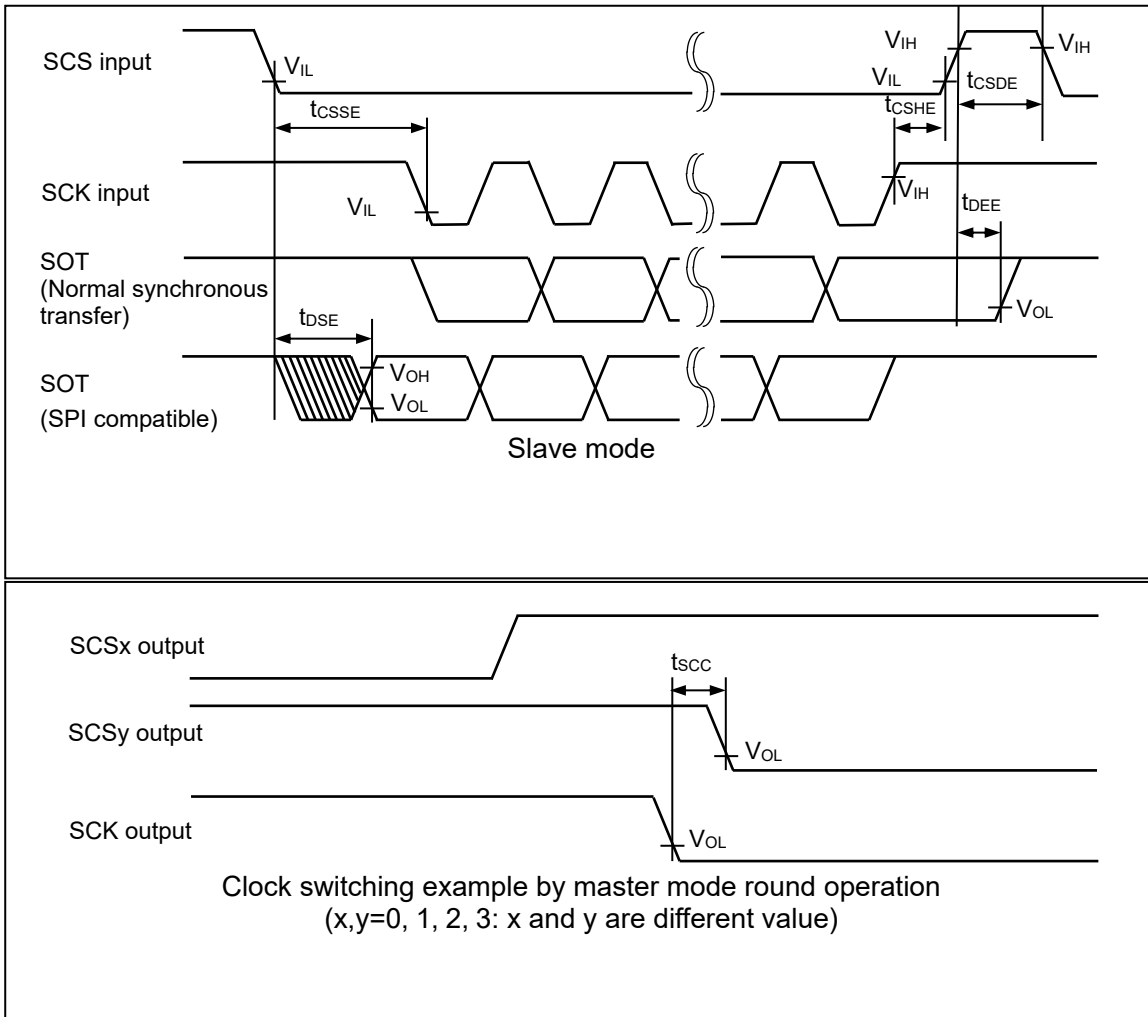
For details on \*1, \*2, and \*3 above, see the Traveo™ Platform Hardware Manual.

\*4 t<sub>CLK\_LCPnA</sub> n = 0:ch.0 to ch.4, n = 1:ch.8 to ch.12

**Notes:**

- This is the AC characteristic in CLK synchronized mode.
- CL is the load capacitance applied to pins during testing.
- The maximum baud rate is limited by the internal operating clock used and other parameters.  
For details, see the Traveo™ Platform Hardware Manual.





## (6) Serial Chip Select Used (SCSCR:CSEN = 1)

■ Serial clock output signal detect level "L" (SMR, SCSFR:SCINV = 1)

■ Serial chip select inactive level "H" (SCSCR, SCSFR:CSLVL = 1)

(TA: Recommended operating conditions, Vcc3 = 3.3 V ± 0.3 V, Vcc5 = DVcc = 5.0 V ± 10 % / 3.3 V ± 0.3 V, Vcc53 = 5.0 V ± 10 % / 3.3 V ± 0.3 V, Vss = DVss = 0.0 V, Vcc12 = 1.15 V ± 0.06 V)

Parameter	Symbol	Pin Name	Conditions	Value		Unit	Remarks
				Min	Max		
SCS ↓ → SCK ↑ setup time	t <sub>CSSI</sub>	SCK0, SCK1, SCK2_1, SCK3_1, SCK4, SCK8 to SCK12, SCK16 to SCK17	Master mode (CL = 20 pF, I <sub>OL</sub> = -5 mA, I <sub>OH</sub> = 5 mA)	t <sub>CSSU</sub> <sup>*1-15</sup>	-	ns	
SCK ↓ → SCS ↑ hold time	t <sub>CSHI</sub>	SCS0x, SCS1x, SCS2x_1, SCS3x_1, SCS4, SCS8x to SCS12x, SCS16x to SCS17x		t <sub>CSHD</sub> <sup>*2+0</sup>	-	ns	
SCS deselect time	t <sub>CSDI</sub>	SCS0x, SCS1x, SCS2x_1, SCS3x_1, SCS4, SCS8x to SCS12x		t <sub>CSDS</sub> <sup>*3-15</sup> +5t <sub>CLK_LCPnA</sub> <sup>*4</sup>	-	ns	
		SCS16x to SCS17x		t <sub>CSDS</sub> <sup>*3-15</sup> +5t <sub>CLK_COMP</sub>	-	ns	
SCS ↓ → SCK ↑ setup time	t <sub>CSSI</sub>	SCK2_0, SCK3_0, SCS2x_0, SCS3x_0	Master Mode (CL = 20 pF, I <sub>OL</sub> = -10 mA, I <sub>OH</sub> = 10 mA)	t <sub>CSSU</sub> <sup>*1-10</sup>	-	ns	
SCK ↓ → SCS ↑ hold time	t <sub>CSHI</sub>			t <sub>CSHD</sub> <sup>*2+0</sup>	-	ns	
SCS deselect time	t <sub>CSDI</sub>			SCS2x_0, SCS3x_0	t <sub>CSDS</sub> <sup>*3-10</sup> +5t <sub>CLK_LCPnA</sub> <sup>*4</sup>	-	ns
SCS ↓ → SCK ↑ setup time	t <sub>CSSE</sub>	SCK0 to SCK4, SCK8 to SCK12, SCS0x to SCS4x, SCS8x to SCS12x	Slave mode (CL = 20 pF, I <sub>OL</sub> = -5 mA, I <sub>OH</sub> = 5 mA)	4t <sub>CLK_LCPnA</sub> <sup>*4</sup> +15	-	ns	
		SCK16 to SCK17, SCS16x to SCS17x		4t <sub>CLK_COMP</sub> +15	-	ns	
SCK ↓ → SCS ↑ hold time	t <sub>CSHE</sub>	SCK0 to SCK4, SCK8 to SCK12, SCK16 to SCK17, SCS0x to SCS4x, SCS8x to SCS12x, SCS16x to SCS17x		0	-	ns	
SCS deselect time	t <sub>CSDE</sub>	SCS0x to SCS4x, SCS8x to SCS12x		4t <sub>CLK_LCPnA</sub> <sup>*4</sup> +15	-	ns	
		SCS16x to SCS17x		4t <sub>CLK_COMP</sub> +15	-	ns	
SCS ↓ → SOT delay time	t <sub>DSE</sub>	SCS0x to SCS4x, SCS8x to SCS12x, SCS16x to SCS17x,		-	40	ns	
SCS ↑ → SOT delay time	t <sub>DEE</sub>	SOT0 to SOT4, SOT8 to SOT12, SOT16 to SOT17		0	-	ns	

Parameter	Symbol	Pin Name	Conditions	Value		Unit	Remarks
				Min	Max		
SCK ↑ → SCS ↓ clock switching time	t <sub>SCC</sub>	SCK0, SCK1, SCK2_1, SCK3_1, SCK4, SCK8 to SCK12, SCS0x, SCS1x, SCS2x_1, SCS3x_1, SCS4, SCS8x to SCS12x	Master mode round operation (CL = 20 pF, I <sub>OL</sub> = -5 mA, I <sub>OH</sub> = 5 mA)	4t <sub>CLK_LCPnA</sub> <sup>*4</sup> +0	4t <sub>CLK_LCPnA</sub> <sup>*</sup> +15	ns	
		SCK16 to SCK17 SCS16x to SCS17x		4t <sub>CLK_COMP</sub> +0	4t <sub>CLK_COMP</sub> +15	ns	
		SCK2_0, SCK3_0, SCS2x_0, SCS3x_0	Master mode round operation (CL = 20 pF, I <sub>OL</sub> = -10 mA, I <sub>OH</sub> = 10 mA)	4t <sub>CLK_LCPnA</sub> <sup>*4</sup> +0	4t <sub>CLK_LCPnA</sub> <sup>*</sup> +10	ns	

\*1: t<sub>CSSU</sub> = SCSTR:CSSU[7:0] x serial chip select timing operating clock

\*2: t<sub>CSDH</sub> = SCSTR:CSDH[7:0] x serial chip select timing operating clock

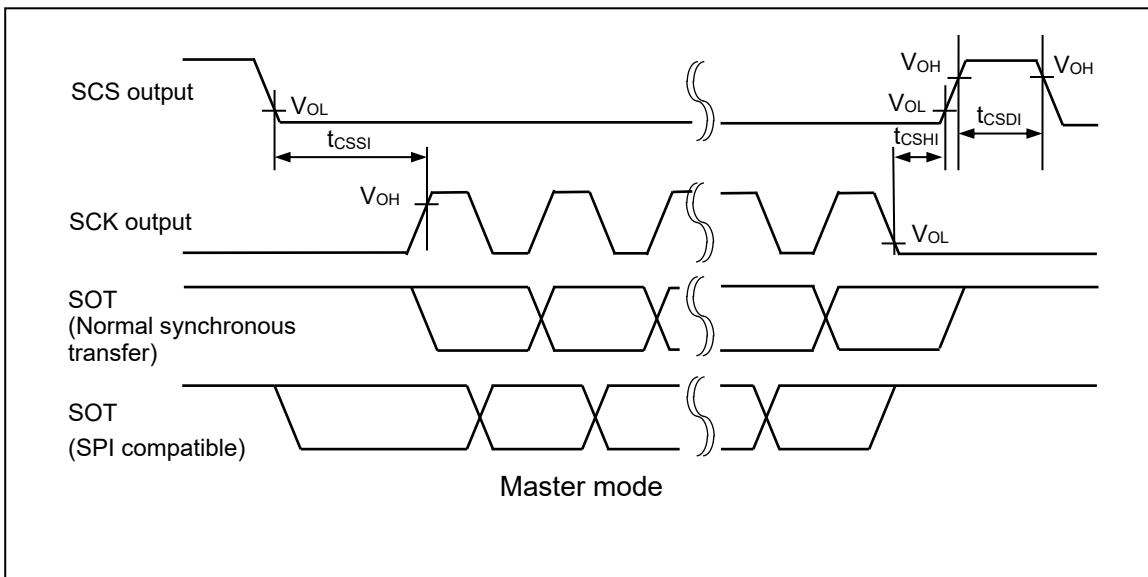
\*3: t<sub>CSDS</sub> = SCSTR:CSDS[15:0] x serial chip select timing operating clock

For details on \*1, \*2, and \*3 above, see the Traveo™ Platform Hardware Manual.

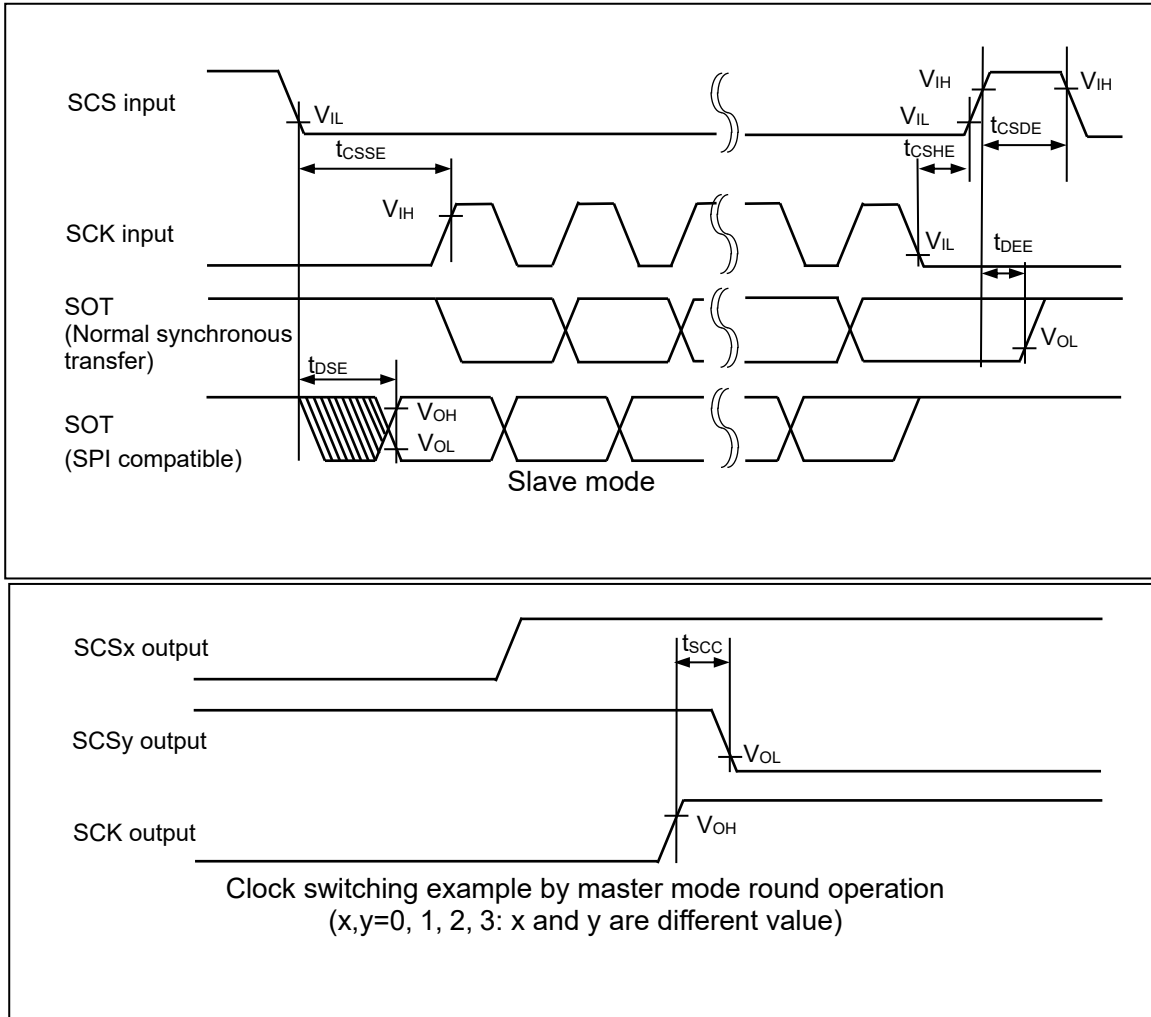
\*4 t<sub>CLK\_LCPnA</sub> n = 0:ch.0 to ch.4, n = 1:ch.8 to ch.12

**Notes:**

- This is the AC characteristic in CLK synchronized mode.
- CL is the load capacitance applied to pins during testing.
- The maximum baud rate is limited by the internal operating clock used and other parameters. For details, see the Traveo™ Platform Hardware Manual.







**(7) Serial Chip Select Used (SCSCR:CSEN = 1)**

■ Serial clock output signal detect level "H" (SMR, SCSFR:SCINV = 0)

■ Serial Chip select inactive level "L" (SCSCR, SCSFR:CSLVL = 0

(TA: Recommended operating conditions, Vcc3 = 3.3 V ± 0.3 V, Vcc5 = DVcc = 5.0 V ± 10 % / 3.3 V ± 0.3 V, Vcc53 = 5.0 V ± 10 % / 3.3 V ± 0.3 V, Vss = DVss = 0.0 V, Vcc12 = 1.15 V ± 0.06 V)

Parameter	Symbol	Pin Name	Conditions	Value		Unit	Remarks
				Min	Max		
SCS ↑ → SCK ↓ setup time	t <sub>CSSI</sub>	SCK0, SCK1, SCK2_1, SCK3_1, SCK4, SCK8 to SCK12, SCK16 to SCK17	Master mode (CL = 20 pF, I <sub>OL</sub> = -5 mA, I <sub>OH</sub> = 5 mA)	t <sub>CSSU</sub> <sup>*1-15</sup>	-	ns	
SCK ↑ → SCS ↓ hold time	t <sub>CSHI</sub>	SCS0x, SCS1x, SCS2x_1, SCS3x_1, SCS4, SCS8x to SCS12x, SCS16x to SCS17x		t <sub>CSHD</sub> <sup>*2+0</sup>	-	ns	
SCS deselect time	t <sub>CSDI</sub>	SCS0x, SCS1x, SCS2x_1, SCS3x_1, SCS4, SCS8x to SCS12x		t <sub>CSDS</sub> <sup>*3-15</sup> +5 t <sub>CLK_LCPnA</sub> <sup>*4</sup>	-	ns	
		SCS16x to SCS17x		t <sub>CSDS</sub> <sup>*3-15</sup> +5t <sub>CLK_COMP</sub>	-	ns	
SCS ↑ → SCK ↓ setup time	t <sub>CSSI</sub>	SCK2_0, SCK3_0, SCS2x_0, SCS3x_0	Master Mode (CL = 20 pF, I <sub>OL</sub> = -10 mA, I <sub>OH</sub> = 10 mA)	t <sub>CSSU</sub> <sup>*1-10</sup>	-	ns	
SCK ↑ → SCS ↓ hold time	t <sub>CSHI</sub>			t <sub>CSHD</sub> <sup>*2+0</sup>	-	ns	
SCS deselect time	t <sub>CSDI</sub>			SCS2x_0, SCS3x_0	t <sub>CSDS</sub> <sup>*3-10</sup> +5t <sub>CLK_LCPnA</sub> <sup>*4</sup>	-	ns
SCS ↑ → SCK ↓ setup time	t <sub>CSSE</sub>	SCK0 to SCK4, SCK8 to SCK12 SCS0x to SCS4x, SCS8x to SCS12x	Slave mode (CL = 20 pF, I <sub>OL</sub> = -5 mA, I <sub>OH</sub> = 5 mA)	4t <sub>CLK_LCPnA</sub> <sup>*4</sup> +15	-	ns	
		SCK16 to SCK17, SCS16x to SCS17x		4t <sub>CLK_COMP</sub> +15	-	ns	
SCK ↑ → SCS ↓ hold time	t <sub>CSHE</sub>	SCK0 to SCK4, SCK8 to SCK12, SCK16 to SCK17, SCS0x to SCS4x, SCS8x to SCS12x, SCS16x to SCS17x		0	-	ns	
SCS deselect time	t <sub>CSDE</sub>	SCS0x to SCS4x, SCS8x to SCS12x		4t <sub>CLK_LCPnA</sub> <sup>*4</sup> +15	-	ns	
		SCS16x to SCS17x		4t <sub>CLK_COMP</sub> +15	-	ns	
SCS ↑ → SOT delay time	t <sub>DSE</sub>	SCS0x to SCS4x, SCS8x to SCS12x, SCS16x to SCS17x,		-	40	ns	
SCS ↓ → SOT delay time	t <sub>DEE</sub>	SOT0 to SOT4, SOT8 to SOT12, SOT16 to SOT17		0	-	ns	

Parameter	Symbol	Pin Name	Conditions	Value		Unit	Remarks
				Min	Max		
SCK ↓ → SCS ↑ clock switching time	t <sub>SCC</sub>	SCK0, SCK1, SCK2_1, SCK3_1, SCK4, SCK8 to SCK12 SCS0x, SCS1x, SCS2x_1, SCS3x_1, SCS4, SCS8x to SCS12x	Master mode round operation (CL = 20 pF, I <sub>OL</sub> = -5 mA, I <sub>OH</sub> = 5 mA)	4t <sub>CLK_LCPnA</sub> * <sup>4</sup> +0	4t <sub>CLK_LCPnA</sub> * +15	ns	
		SCK16 to SCK17 SCS16x to SCS17x		4t <sub>CLK_COMP</sub> +0	4t <sub>CLK_COMP</sub> +15	ns	
		SCK2_0, SCK3_0, SCS2x_0, SCS3x_0	Master mode round operation (CL = 20 pF, I <sub>OL</sub> = -10 mA, I <sub>OH</sub> = 10 mA)	4t <sub>CLK_LCPnA</sub> * +0	4t <sub>CLK_LCPnA</sub> * +10	ns	

\*1: t<sub>CSSU</sub> = SCSTR:CSSU[7:0] x serial chip select timing operating clock

\*2: t<sub>CSDH</sub> = SCSTR:CSDH[7:0] x serial chip select timing operating clock

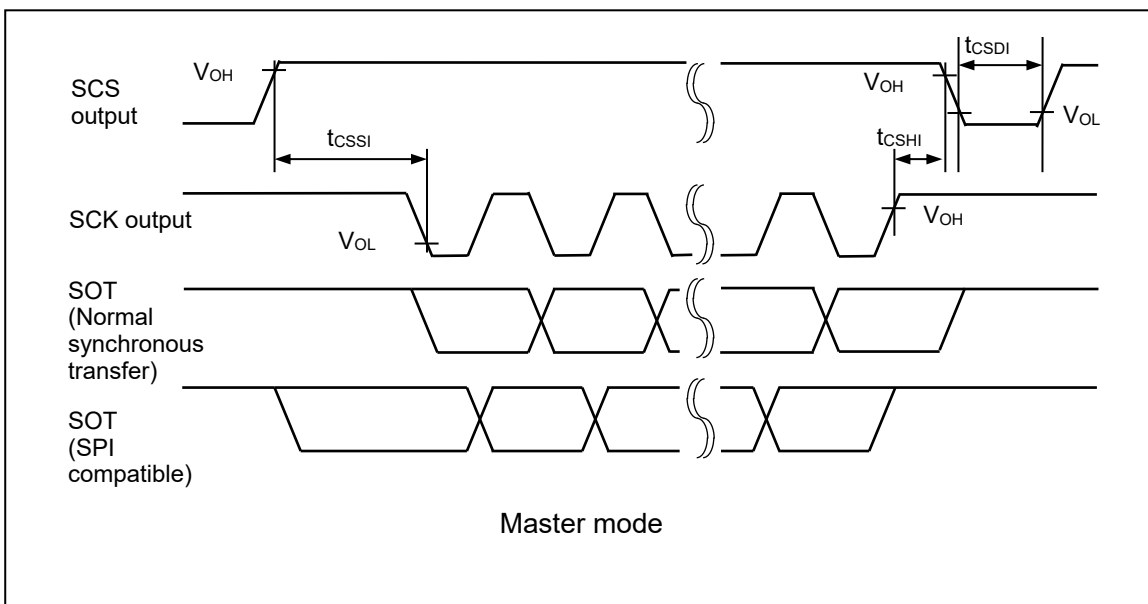
\*3: t<sub>CSDS</sub> = SCSTR:CSDS[15:0] x serial chip select timing operating clock

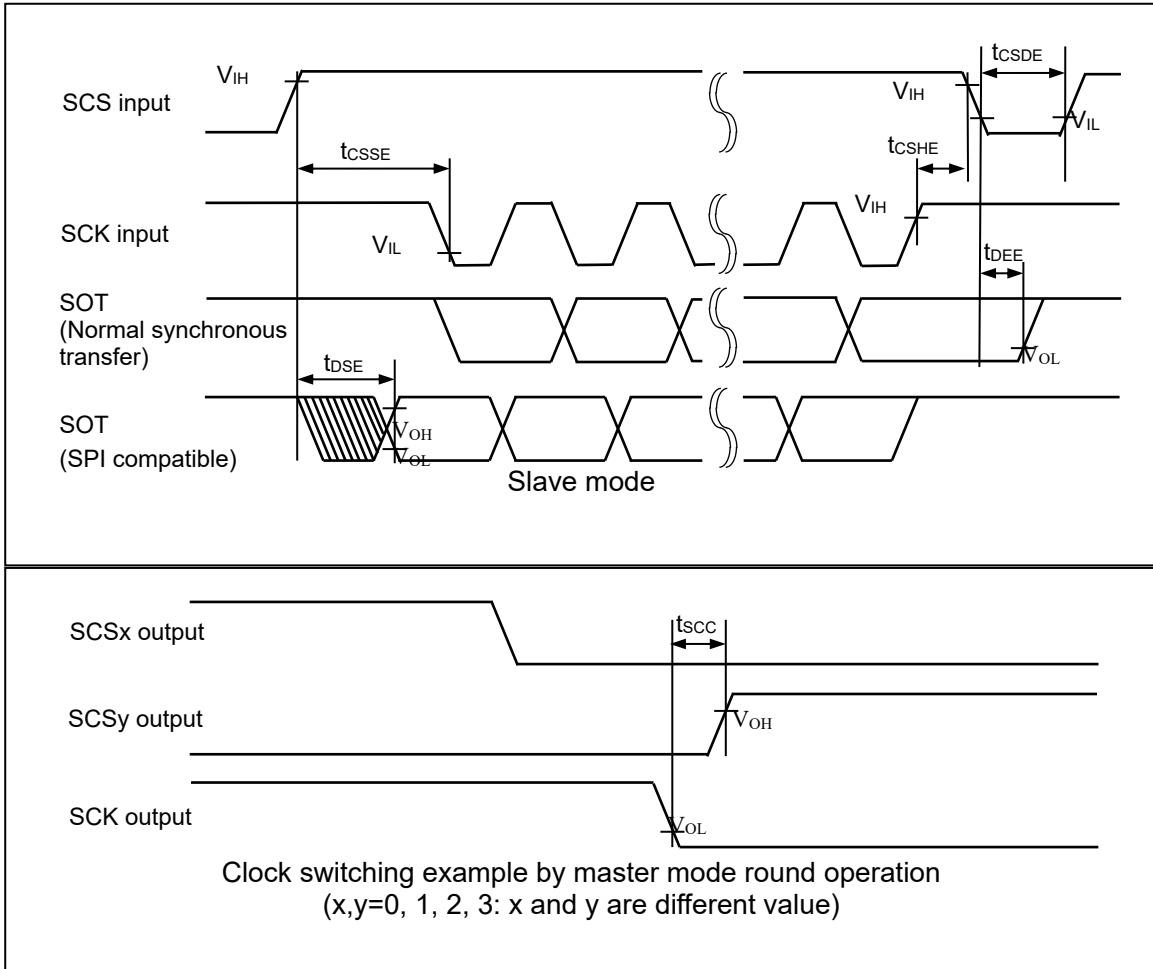
For details on \*1, \*2, and \*3 above, see the Traveo™ Platform Hardware Manual.

\*4 t<sub>CLK\_LCPnA</sub> n = 0:ch.0 to ch.4, n = 1:ch.8 to ch.12

**Notes:**

- This is the AC characteristic in CLK synchronized mode.
- CL is the load capacitance applied to pins during testing.
- The maximum baud rate is limited by the internal operating clock used and other parameters. For details, see the Traveo™ Platform Hardware Manual.





## (8) Serial Chip Select Used (SCSCR:CSEN = 1)

■ Serial clock output signal detect level "L" (SMR, SCSFR:SCINV = 1)

■ Serial Chip select inactive level "L" (SCSCR, SCSFR:CSLVL = 0)

(TA: Recommended operating conditions, Vcc3 = 3.3 V ± 0.3 V, Vcc5 = DVcc = 5.0 V ± 10 % / 3.3 V ± 0.3 V, Vcc53 = 5.0 V ± 10 % / 3.3 V ± 0.3 V, Vss = DVss = 0.0 V, Vcc12 = 1.15 V ± 0.06 V)

Parameter	Symbol	Pin Name	Conditions	Value		Unit	Remarks
				Min	Max		
SCS ↑ → SCK ↑ setup time	t <sub>CSSI</sub>	SCK0, SCK1, SCK2_1, SCK3_1, SCK4, SCK8 to SCK12, SCK16 to SCK17	Master mode (CL = 20 pF, I <sub>OL</sub> = -5 mA, I <sub>OH</sub> = 5 mA)	t <sub>CSSU</sub> <sup>*1-15</sup>	-	ns	
SCK ↓ → SCS ↓ hold time	t <sub>CSDI</sub>	SCS0x, SCS1x, SCS2x_1, SCS3x_1, SCS4, SCS8x to SCS12x, SCS16x to SCS17x		t <sub>CSDH</sub> <sup>*2+0</sup>	-	ns	
SCS deselect time	t <sub>CSDI</sub>	SCS0x, SCS1x, SCS2x_1, SCS3x_1, SCS4, SCS8x to SCS12x		t <sub>CSDS</sub> <sup>*3-15</sup> + 5t <sub>CLK_LCPnA</sub> <sup>*4</sup>	-	ns	
		SCS16x to SCS17x		t <sub>CSDS</sub> <sup>*3-15</sup> + 5t <sub>CLK_COMP</sub>	-	ns	
SCS ↑ → SCK ↑ setup time	t <sub>CSSI</sub>	SCK2_0, SCK3_0, SCS2x_0, SCS3x_0	Master Mode (CL = 20 pF, I <sub>OL</sub> = -10 mA, I <sub>OH</sub> = 10 mA)	t <sub>CSSU</sub> <sup>*1-10</sup>	-	ns	
SCK ↓ → SCS ↓ hold time	t <sub>CSDI</sub>			t <sub>CSDH</sub> <sup>*2+0</sup>	-	ns	
SCS deselect time	t <sub>CSDI</sub>			t <sub>CSDS</sub> <sup>*3-10</sup> + 5t <sub>CLK_LCPnA</sub> <sup>*4</sup>	-	ns	
SCS ↑ → SCK ↑ setup time	t <sub>CSSSE</sub>	SCK0 to SCK4, SCK8 to SCK12, SCS0x to SCS4x, SCS8x to SCS12x	Slave mode (CL = 20 pF, I <sub>OL</sub> = -5 mA, I <sub>OH</sub> = 5 mA)	4t <sub>CLK_LCPnA</sub> <sup>*4</sup> + 15	-	ns	
		SCK16 to SCK17, SCS16x to SCS17x		4t <sub>CLK_COMP</sub> + 15	-	ns	
SCK ↓ → SCS ↓ hold time	t <sub>CSDH</sub>	SCK0 to SCK4, SCK8 to SCK12, SCK16 to SCK17, SCS0x to SCS4x, SCS8x to SCS12x, SCS16x to SCS17x		0	-	ns	
SCS deselect time	t <sub>CSDSE</sub>	SCS0x to SCS4x, SCS8x to SCS12x		4t <sub>CLK_LCPnA</sub> <sup>*4</sup> + 15	-	ns	
		SCS16x to SCS17x		4t <sub>CLK_COMP</sub> + 15	-	ns	
SCS ↑ → SOT delay time	t <sub>DSE</sub>	SCS0x to SCS4x, SCS8x to SCS12x, SCS16x to SCS17x,		-	40	ns	
SOT0 to SOT4, SOT8 to SOT12, SOT16 to SOT17	t <sub>DEE</sub>	0		-	ns		

Parameter	Symbol	Pin Name	Conditions	Value		Unit	Remarks
				Min	Max		
SCK ↑ → SCS ↑ clock switching time	t <sub>SCC</sub>	SCK0, SCK1, SCK2_1, SCK3_1, SCK4, SCK8 to SCK12, SCS0x, SCS1x, SCS2x_1, SCS3x_1, SCS4, SCS8x to SCS12x	Master mode round operation (CL = 20 pF, I <sub>OL</sub> = -5 mA, I <sub>OH</sub> = 5 mA)	4t <sub>CLK_LCPnA</sub> <sup>*4+</sup> 0	4t <sub>CLK_LCPnA</sub> <sup>*</sup> 4 +15	ns	
		SCK16 to SCK17, SCS16x to SCS17x		4t <sub>CLK_COMP</sub> +0	4t <sub>CLK_COMP</sub> +15		
		SCK2_0, SCK3_0, SCS2x_0, SCS3x_0	Master mode round operation (CL = 20 pF, I <sub>OL</sub> = -10 mA, I <sub>OH</sub> = 10 mA)	4t <sub>CLK_LCPnA</sub> <sup>*4</sup> +0	4t <sub>CLK_LCPnA</sub> <sup>*</sup> 4 +10	ns	

\*1: t<sub>CSSU</sub> = SCSTR:CSSU[7:0] x serial chip select timing operating clock

\*2: t<sub>CSDH</sub> = SCSTR:CSDH[7:0] x serial chip select timing operating clock

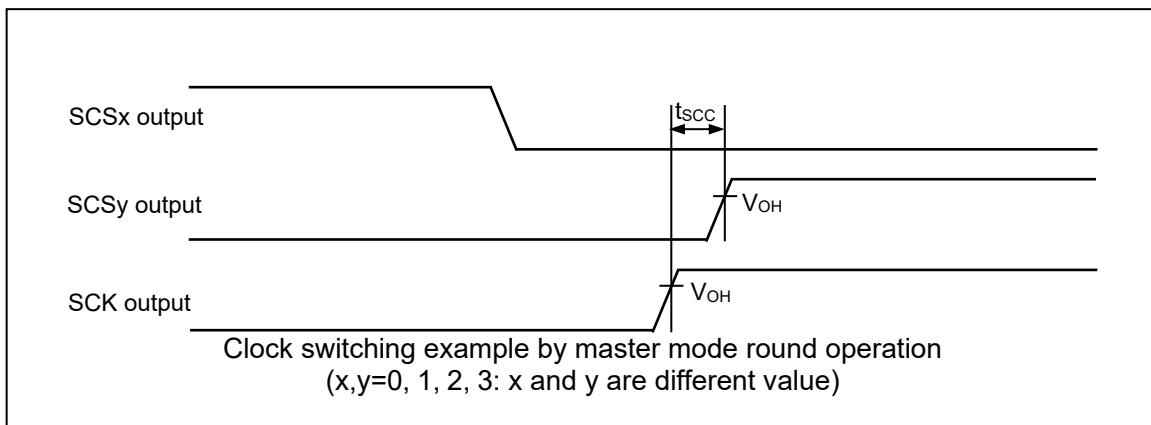
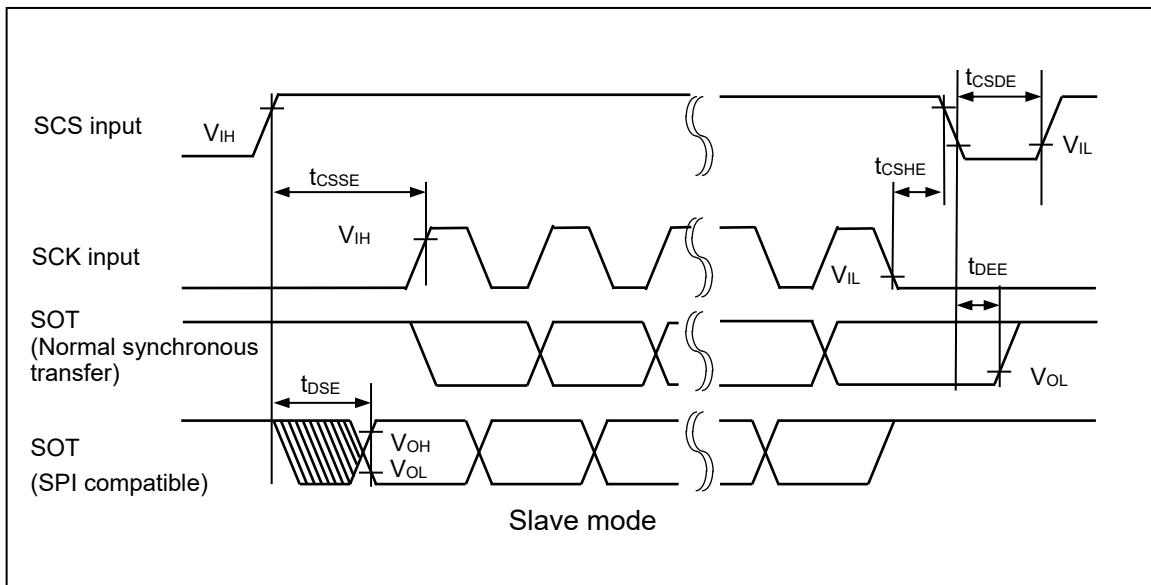
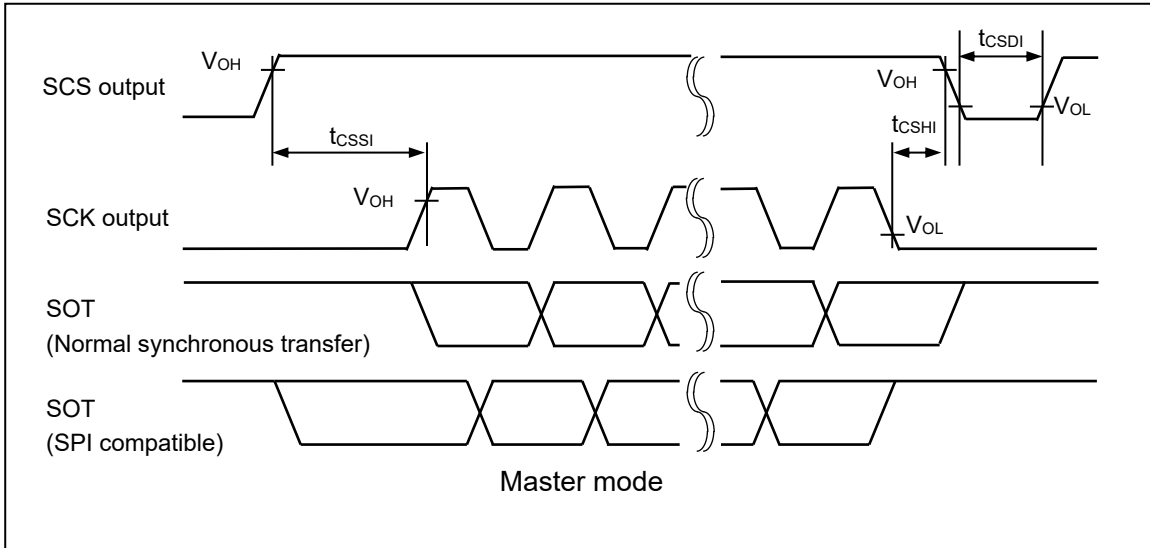
\*3: t<sub>CSDS</sub> = SCSTR:CSDS[15:0] x serial chip select timing operating clock

For details on \*1, \*2, and \*3 above, see the Traveo™ Platform Hardware Manual.

\*4 t<sub>CLK\_LCPnA</sub> n = 0:ch.0 to ch.4, n = 1:ch.8 to ch.12

**Notes:**

- This is the AC characteristic in CLK synchronized mode.
- CL is the load capacitance applied to pins during testing.
- The maximum baud rate is limited by the internal operating clock used and other parameters. For details, see the Traveo™ Platform Hardware Manual.



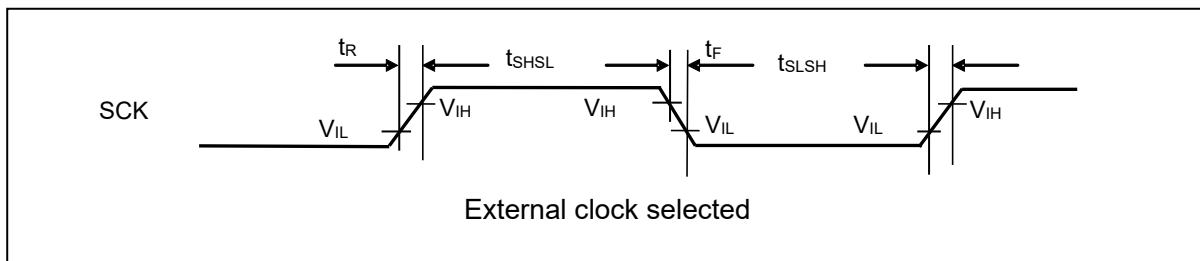
LIN interface (v2.1) (LIN communication control interface (v2.1)) timing (SMR:MD2-0 = 0b011)

### (1) External Clock Selected (BGR:EXT = 1)

(TA: Recommended operating conditions, Vcc3 = 3.3 V ± 0.3 V, Vcc5 = DVcc = 5.0 V ± 10 % / 3.3 V ± 0.3 V, Vcc53 = 5.0 V ± 10 % / 3.3 V ± 0.3 V, Vss = DVss = 0.0 V, Vcc12 = 1.15 V ± 0.06 V)

Parameter	Symbol	Pin Name	Conditions	Value		Unit	Remarks
				Min	Max		
Serial clock "L" pulse width	t <sub>SLSH</sub>	SCK0 to SCK4, SCK8 to SCK12	-	t <sub>CLK_LCPnA</sub> <sup>*1</sup> +10	-	ns	
		SCK16 to SCK17		t <sub>CLK_COMP</sub> +10	-	ns	
Serial clock "H" pulse width	t <sub>SHSL</sub>	SCK0 to SCK4, SCK8 to SCK12		t <sub>CLK_LCPnA</sub> <sup>*1</sup> +10	-	ns	
		SCK16 to SCK17		t <sub>CLK_COMP</sub> +10	-	ns	
SCK falling time	t <sub>F</sub>	SCK0 to SCK4, SCK8 to SCK12, SCK16 to SCK17	-	5	ns		
SCK rising time	t <sub>R</sub>		-	5	ns		

\*1: n = 0:ch.0 to ch.4, n = 1:ch.8 to ch.12





I<sup>2</sup>C timing (SMR:MD2-0 = 0b100)

(TA: Recommended operating conditions, V<sub>CC5</sub> = V<sub>CC53</sub> = 5.0 V ± 10 %, V<sub>CC12</sub> = 1.15 V ± 0.06 V, V<sub>SS</sub> = 0.0 V)

Parameter	Symbol	Pin Name	Conditions	Standard Mode		Fast Mode		Unit	Remarks
				Min	Max	Min	Max		
SCL clock frequency	f <sub>SCL</sub>	SCL0, SCL1, SCL4, SCL8 to SCL12, SCL16 to SCL17	C <sub>L</sub> = 50 pF, R = (V <sub>p</sub> /I <sub>OL</sub> ) <sup>*1</sup>	0	100	0	400	kHz	
Repeat "start" condition hold time SDA↓ → SCL↓	t <sub>HDSTA</sub>	SDA0, SDA1, SDA4 SDA8 to SDA12, SDA16 to SDA17, SCL0, SCL1, SCL4, SCL8 to SCL12, SCL16 to SCL17		4.0	-	0.6	-	μs	
Period of "L" for SCL clock	t <sub>LOW</sub>	SCL0, SCL1, SCL4, SCL8 to SCL12, SCL16 to SCL17		4.7	-	1.3	-	μs	
Period of "H" for SCL clock	t <sub>HIGH</sub>	SCL0, SCL1, SCL4, SCL8 to SCL12, SCL16 to SCL17		4.0	-	0.6	-	μs	
Repeat "start" condition setup time SCL↑ → SDA↓	t <sub>SUSTA</sub>	SDA0, SDA1, SDA4 SDA8 to SDA12, SDA16 to SDA17, SCL0, SCL1, SCL4, SCL8 to SCL12, SCL16 to SCL17		4.7	-	0.6	-	μs	
Data hold time SCL↓ → SDA↑	t <sub>HDDAT</sub>	SDA0, SDA1, SDA4 SDA8 to SDA12, SDA16 to SDA17, SCL0, SCL1, SCL4, SCL8 to SCL12, SCL16 to SCL17		0	3.45 <sup>*2</sup>	0	0.9 <sup>*3</sup>	μs	
Data setup time SDA↑ → SCL↑	t <sub>SUDAT</sub>	SDA0, SDA1, SDA4 SDA8 to SDA12, SDA16 to SDA17, SCL0, SCL1, SCL4, SCL8 to SCL12, SCL16 to SCL17		250	-	100	-	ns	
"Stop" condition setup time SCL↑ → SDA↑	t <sub>SUSTO</sub>	SDA0, SDA1, SDA4 SDA8 to SDA12, SDA16 to SDA17, SCL0, SCL1, SCL4, SCL8 to SCL12, SCL16 to SCL17		4.0	-	0.6	-	μs	
Bus-free time between "stop" condition and "start" condition	t <sub>BUF</sub>	-		4.7	-	1.3	-	μs	
Noise filter	t <sub>SP</sub>	-		t <sub>NFT</sub> <sup>*4</sup>	-	t <sub>NFT</sub> <sup>*4</sup>	-	ns	

Notes: Only ch.16 and ch.17 are standard mode/high-speed mode correspondence. In ch.0, ch.1, ch.4, and ch.8 to ch.12, only a standard mode is correspondence.

\*1: R and C<sub>L</sub> represent the pull-up resistance and load capacitance of the SCL and SDA output lines, respectively.

V<sub>p</sub> shows that the power-supply voltage of the pull-up resistor and I<sub>OL</sub> shows the V<sub>OL</sub> guarantee current.

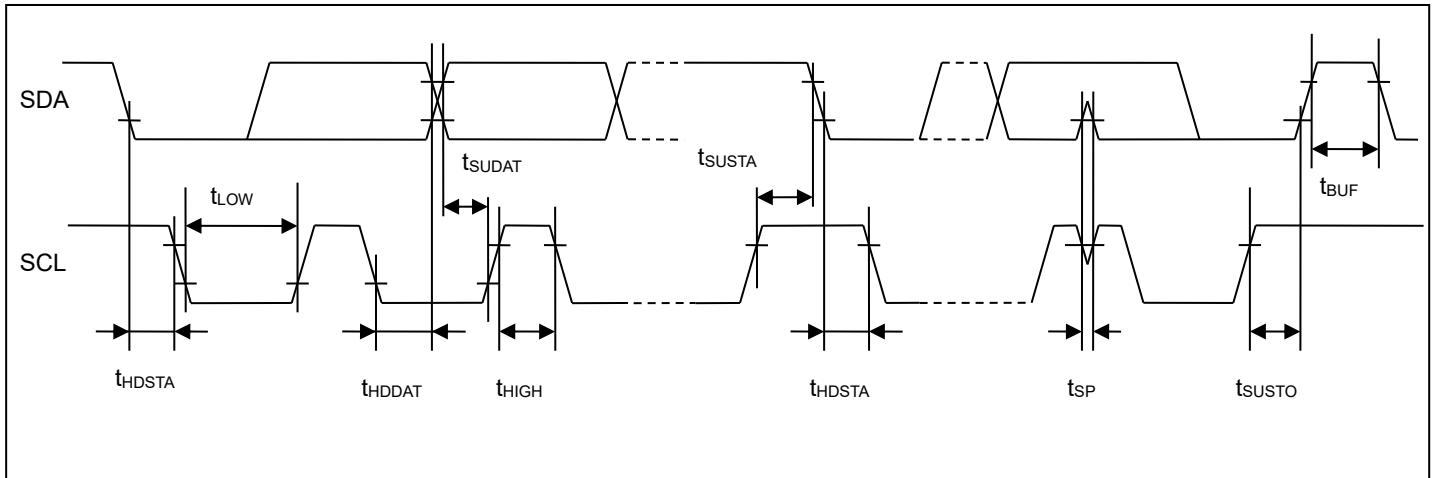
\*2: The maximum t<sub>HDDAT</sub> only has to be met if the device does not extend the "L" width (t<sub>LOW</sub>) of the SCL signal.

\*3: A fast mode I<sup>2</sup>C bus device can be used on a standard mode I<sup>2</sup>C bus system as long as the device satisfies the requirement of "t<sub>SUDAT</sub> ≥ 250 ns".

\*4: t<sub>NFT</sub> = (NFCR:NFT[4:0]+1) x 2 x t<sub>CLK\_LCP0A</sub> (ch.0, ch.1, ch4)

t<sub>NFT</sub> = (NFCR:NFT[4:0]+1) x 2 x t<sub>CLK\_LCP1A</sub> (ch.8 to ch.12)

t<sub>NFT</sub> = (NFCR:NFT[4:0]+1) x 2 x t<sub>CLK\_COMP</sub> (ch.16 to ch.17)



## 9.1.4.7 Timer Input

(T<sub>A</sub>: Recommended operating conditions, V<sub>cc3</sub> = 3.3 V ± 0.3 V, V<sub>cc5</sub> = DV<sub>cc</sub> = 5.0 V ± 10 %, V<sub>cc53</sub> = 5.0 V ± 10 % / 3.3 V ± 0.3 V, V<sub>ss</sub> = DV<sub>ss</sub> = 0.0 V, V<sub>cc12</sub> = 1.15 V ± 0.06 V)

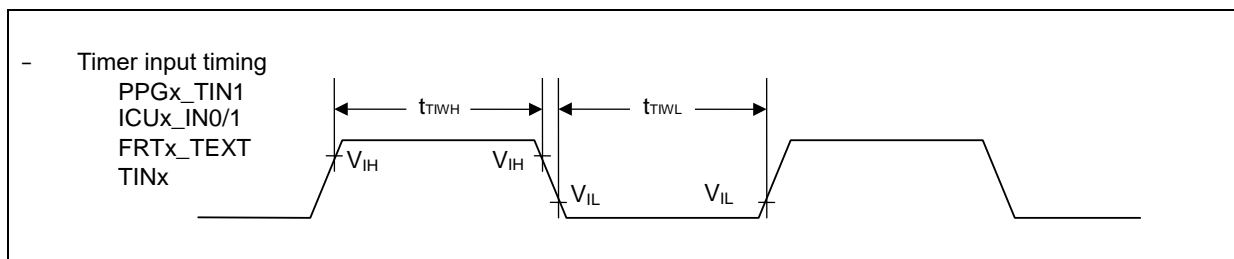
Parameter	Symbol	Pin Name	Conditions	Value		Unit	Remarks
				Min	Max		
Input pulse width	t <sub>TWH</sub> , t <sub>TWL</sub>	PPG0_TIN1 to PPG31_TIN1	-	4t <sub>CLK_LCPnA</sub> <sup>*1</sup>	-	ns	4t <sub>CLK_LCPnA</sub> <sup>*1</sup> ≥ 100 ns
				100			4t <sub>CLK_LCPnA</sub> <sup>*1</sup> < 100 ns
		ICU0_IN0 to ICU2_IN0, ICU8_IN0 to ICU10_IN0, ICU0_IN1 to ICU2_IN1, ICU8_IN1 to ICU10_IN1	-	4t <sub>CLK_LCPnA</sub> <sup>*2</sup>	-	ns	4t <sub>CLK_LCPnA</sub> <sup>*2</sup> ≥ 100 ns
				100			4t <sub>CLK_LCPnA</sub> <sup>*2</sup> < 100 ns
		FRT0_TEXT to FRT4_TEXT, FRT8_TEXT to FRT10_TEXT	-	4t <sub>CLK_LCPnA</sub> <sup>*3</sup>	-	ns	4t <sub>CLK_LCPnA</sub> <sup>*3</sup> ≥ 100 ns
				100			4t <sub>CLK_LCPnA</sub> <sup>*3</sup> < 100 ns
		TIN0 to TIN1, TIN16 to TIN17	-	4t <sub>CLK_LCPnA</sub> <sup>*4</sup>	-	ns	4t <sub>CLK_LCPnA</sub> <sup>*4</sup> ≥ 100 ns
				100			4t <sub>CLK_LCPnA</sub> <sup>*4</sup> < 100 ns
		TIN48 to TIN49	-	4t <sub>CLK_COMP</sub>	-	ns	4t <sub>CLK_COMP</sub> ≥ 100 ns
				100			4t <sub>CLK_COMP</sub> < 100 ns

\*1: n = 0: unit.0 to unit.5, unit.12 to unit.31, n = 1: unit.6 to unit.11

\*2: n = 0: unit.0 to unit.2, n = 1: unit.8 to unit.10

\*3: n = 0: ch.0 to ch.4, n = 1: ch.8 to ch.10

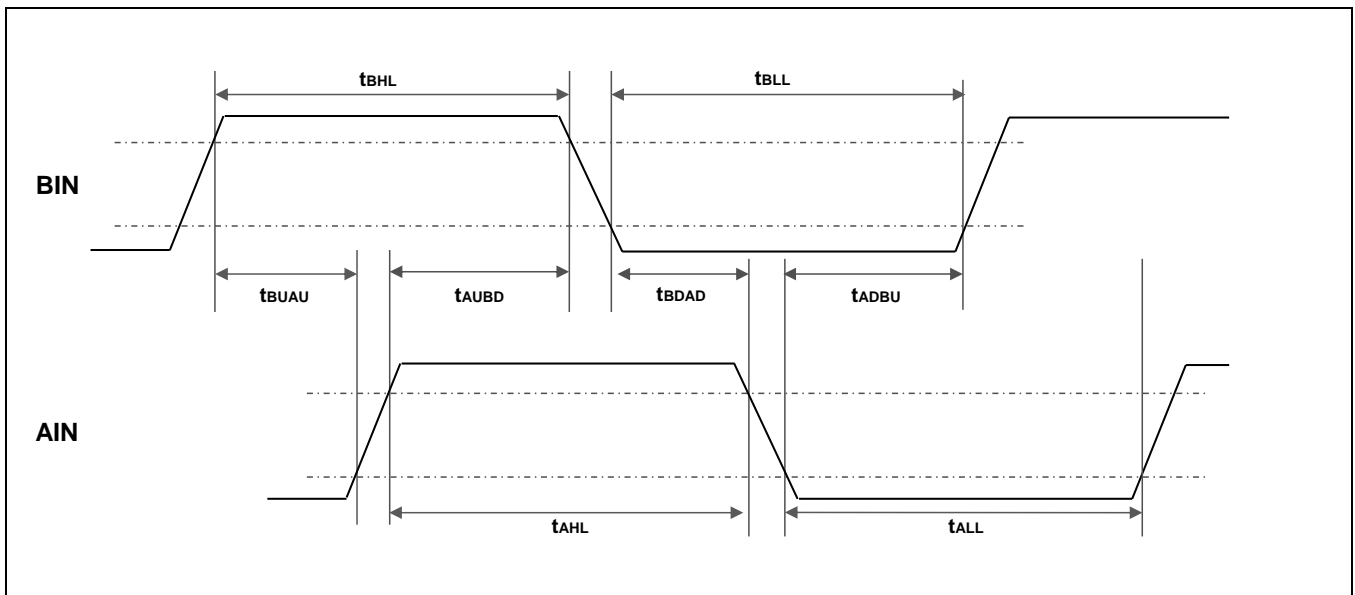
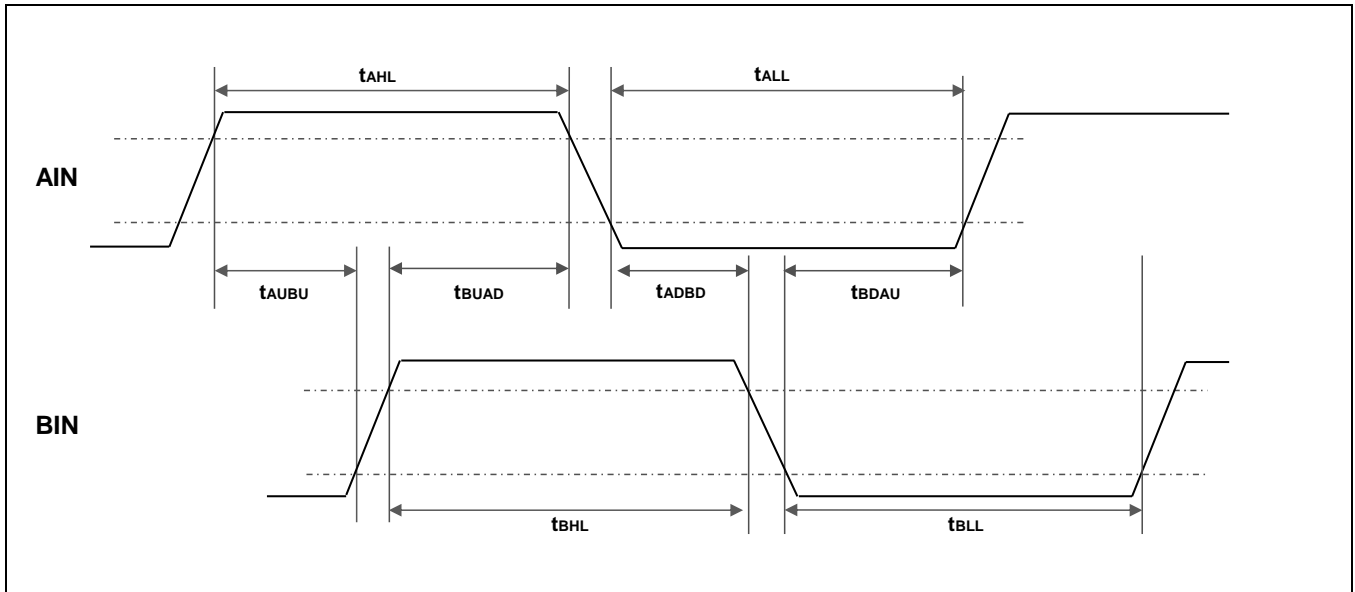
\*4: n = 0: ch.0 to ch.1, n = 1: ch.16 to ch.17

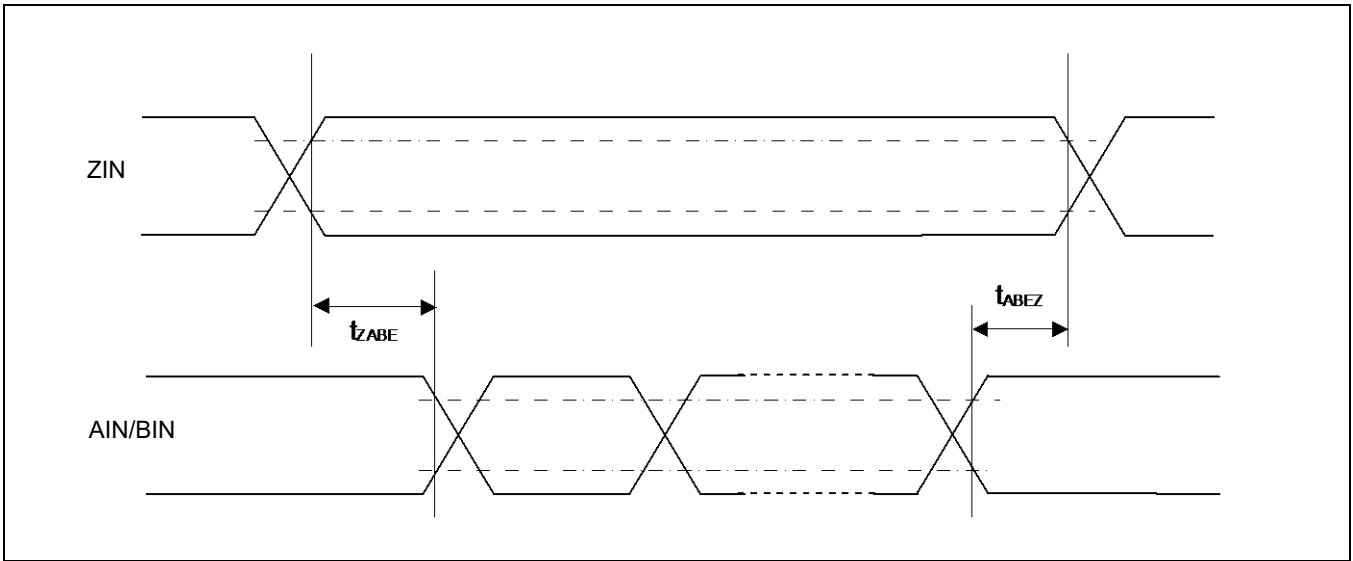
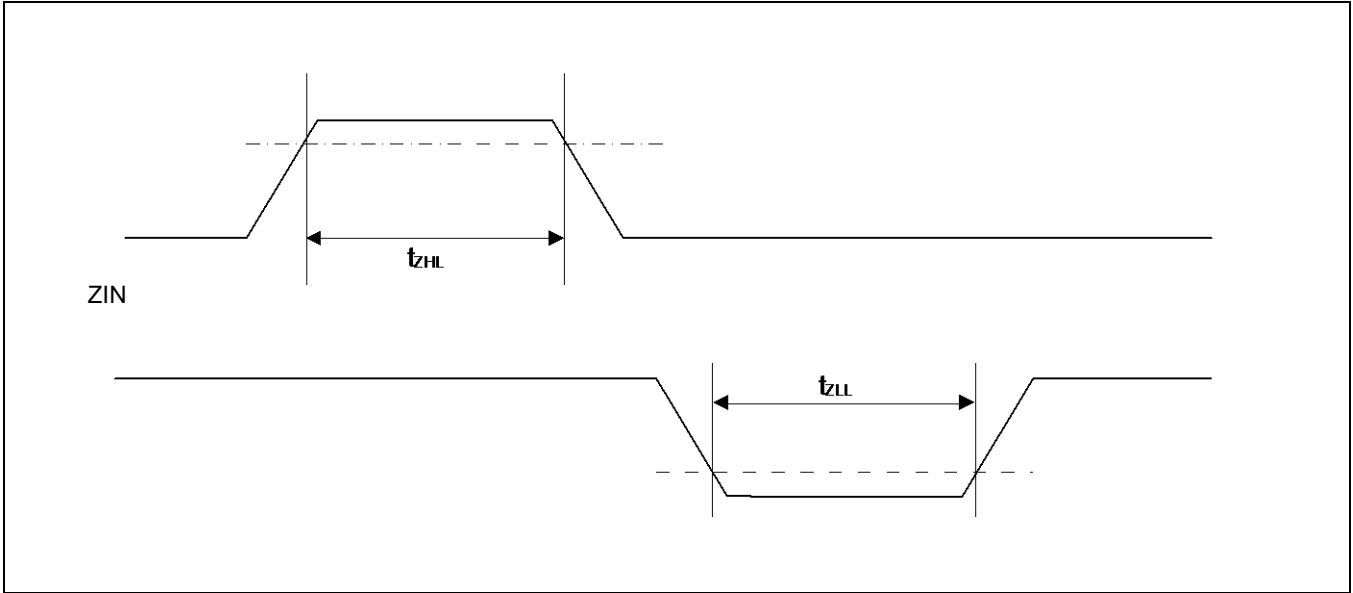


## 9.1.4.8 QPRC timing

(T<sub>A</sub>: Recommended operating conditions, V<sub>CC3</sub> = 3.3 V ± 0.3 V, V<sub>CC5</sub> = DV<sub>CC</sub> = 5.0 V ± 10 %, V<sub>CC53</sub> = 5.0 V ± 10 % / 3.3 V ± 0.3 V, V<sub>SS</sub> = DV<sub>SS</sub> = 0.0 V, V<sub>CC12</sub> = 1.15 V ± 0.06 V)

Parameter	Symbol	Pin Name	Conditions	Value		Unit	Remarks
				Min	Max		
AIN pin "H" width	t <sub>AHL</sub>	AIN8 to AIN9	-	4t <sub>CLK_LCP1A</sub>	-	ns	4t <sub>CLK_LCP1A</sub> ≥ 100 ns
AIN pin "L" width	t <sub>ALL</sub>	AIN8 to AIN9	-				
BIN pin "H" width	t <sub>BHL</sub>	BIN8 to BIN9	-				
BIN pin "L" width	t <sub>BLL</sub>	BIN8 to BIN9	-				
Time from AIN pin "H" level to BIN rise	t <sub>AUBU</sub>	AIN8 to AIN9, BIN8 to BIN9	PC_Mode2 or PC_Mode3				
Time from BIN pin "H" level to AIN fall	t <sub>BUAD</sub>	AIN8 to AIN9, BIN8 to BIN9	PC_Mode2 or PC_Mode3				
Time from AIN pin "L" level to BIN fall	t <sub>ADBD</sub>	AIN8 to AIN9, BIN8 to BIN9	PC_Mode2 or PC_Mode3				
Time from BIN pin "L" level to AIN rise	t <sub>BDAU</sub>	AIN8 to AIN9, BIN8 to BIN9	PC_Mode2 or PC_Mode3				
Time from BIN pin "H" level to AIN rise	t <sub>BUAU</sub>	AIN8 to AIN9, BIN8 to BIN9	PC_Mode2 or PC_Mode3				
Time from AIN pin "H" level to BIN fall	t <sub>AUBD</sub>	AIN8 to AIN9, BIN8 to BIN9	PC_Mode2 or PC_Mode3				
Time from BIN pin "L" level to AIN fall	t <sub>BDAD</sub>	AIN8 to AIN9, BIN8 to BIN9	PC_Mode2 or PC_Mode3				
Time from AIN pin "L" level to BIN rise	t <sub>ADBU</sub>	AIN8 to AIN9, BIN8 to BIN9	PC_Mode2 or PC_Mode3				
ZIN pin "H" width	t <sub>ZHL</sub>	ZIN8 to ZIN9	QCR:CGSC = "0"				
ZIN pin "L" width	t <sub>ZLL</sub>	ZIN8 to ZIN9	QCR:CGSC = "0"				
Time from determined ZIN level to AIN/BIN rise and fall	t <sub>ZABE</sub>	AIN8 to AIN9, BIN8 to BIN9, ZIN8 to ZIN9	QCR:CGSC = "1"				
Time from AIN/BIN rise and fall time to determined ZIN level	t <sub>ABEZ</sub>	AIN8 to AIN9, BIN8 to BIN9, ZIN8 to ZIN9	QCR:CGSC = "1"				

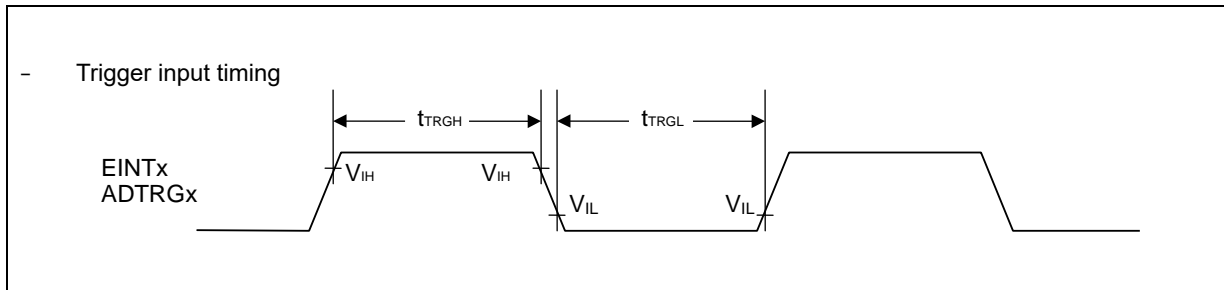




## 9.1.4.9 Trigger Input

(T<sub>A</sub>: Recommended operating conditions, V<sub>CC3</sub> = 3.3 V ± 0.3 V, V<sub>CC5</sub> = DV<sub>CC</sub> = 5.0 V ± 10 %, V<sub>CC53</sub> = 5.0 V ± 10 % / 3.3 V ± 0.3 V, V<sub>SS</sub> = DV<sub>SS</sub> = 0.0 V, V<sub>CC12</sub> = 1.15 V ± 0.06 V)

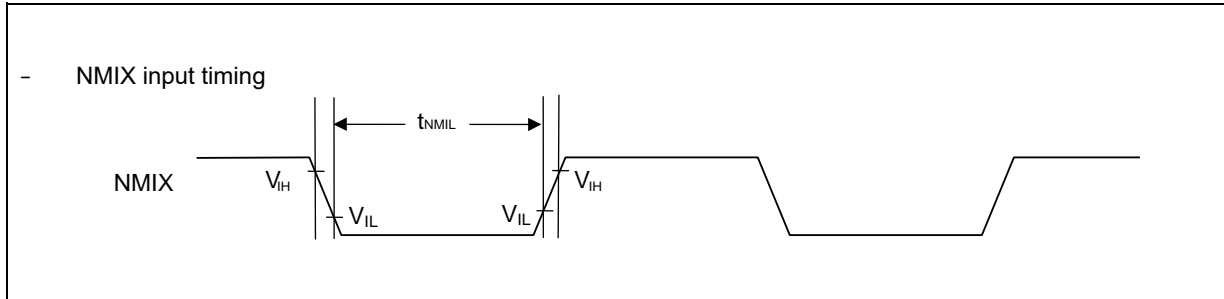
Parameter	Symbol	Pin Name	Conditions	Value		Unit	Remarks
				Min	Max		
Input pulse width	t <sub>TRGH</sub> , t <sub>TRGL</sub>	EINT0 to EINT23	-	100	-	ns	
		ADTRG0 to ADTRG1	-	5t <sub>CLK LCP1A</sub> 100	-	ns	5t <sub>CLK LCP1A</sub> ≥ 100 ns 5t <sub>CLK LCP1A</sub> < 100 ns
		EINT0 to EINT23	-	1	-	μs	Stop mode



## 9.1.4.10 NMI Input

(T<sub>A</sub>: Recommended operating conditions, V<sub>CC5</sub> = 5.0 V ± 10 %, V<sub>SS</sub> = 0.0 V)

Parameter	Symbol	Pin Name	Conditions	Value		Unit	Remarks
				Min	Max		
Input pulse width	t <sub>NMIL</sub>	NMIX	-	300	-	ns	





## 9.1.4.11 Low Voltage Detection (External Voltage)

Low-voltage detection (external low-voltage detection)

(T<sub>A</sub>: Recommended operating conditions, V<sub>SS</sub> = AV<sub>SS</sub> = 0.0 V)

Parameter	Symbol	Pin Name	Conditions	Value			Unit	Remarks	
				Min	Typ	Max			
Supply voltage range	V <sub>DP5</sub>	VCC5	-	3.5 <sup>*3</sup>	-	5.5 <sup>*3</sup>	V		
	V <sub>DP3</sub>	VCC3	-	2.7 <sup>*4</sup>	-	3.6 <sup>*4</sup>			
Detection voltage (before trimming)	V <sub>DLBT</sub>	VCC5	<sup>*1</sup>	3.6 <sup>*3</sup>	4.0 <sup>*3</sup>	4.4 <sup>*3</sup>	V	When power-supply voltage falls and detection level is set initially	
			<sup>*1 *5</sup>	2.3 <sup>*4</sup>	2.6 <sup>*4</sup>	2.9 <sup>*4</sup>			
Detection voltage (after trimming)	V <sub>DLAT</sub>	VCC3	<sup>*1 *5</sup>	2.3	2.6	2.9	V		
			<sup>*1</sup>	3.86 <sup>*3</sup>	4.0 <sup>*3</sup>	4.14 <sup>*3</sup>			
Detection voltage (after trimming)	V <sub>DLAT</sub>	VCC5	<sup>*1 *5</sup>	2.51 <sup>*4</sup>	2.6 <sup>*4</sup>	2.69 <sup>*4</sup>	V	When power-supply voltage falls and detection level is set initially Typ ±3.5 %	
			<sup>*1</sup>	2.51	2.6	2.69			
Hysteresis width	V <sub>HYS</sub>	VCC5	-	-	100	-	mV		When power-supply voltage rises
Low-voltage detection time	T <sub>d</sub>	-	-	-	-	40	μs		
Power supply voltage regulation	-	VCC5	-	-2	-	2	V/ms	<sup>*2</sup>	

\*1: If the fluctuation of the power supply is faster than the low-voltage detection time, there is a possibility to generate or release after the power supply voltage has exceeded the detection voltage range.

\*2: Please suppress the change of the power supply within the range of the power-supply voltage regulation to do a low-voltage detection by detecting voltage (VDL)

\*3: For S6J33xxxSx or S6J33xxxUx or S6J33xxxTx or S6J33xxxVx option.

\*4: For S6J33xxxAx or S6J33xxxBx or S6J33xxxCx or S6J33xxxDx or S6J33xxxEx or S6J33xxxFx or S6J33xxxGx or S6J33xxxHx option.

\*5: These LVD settings cannot be used to reliably generate a reset before voltage dips below minimum guaranteed MCU operation voltage, as these detection levels are below the minimum guaranteed MCU operation voltage (2.7 V).

### Notes:

- The detection/release threshold values of following LVD channels are potentially below supply range defined in 9.1.2 Recommended Operating Condition.

LVDH1 (VCC5)

LVDH2 (VCC3)

- Please use these LVD channels with your own risk.

- Please monitor the external power supplies on the PCB if needed.

- For S6J33xxxSC or S6J33xxxUC or S6J33xxxTC or S6J33xxxVC options:

Depending on the threshold setting, LVDH1 can always detect VCC5 low voltage before the supply drops below the level defined in 9.1.2 Recommended Operating Condition. Please refer to S6J3300 series Hardware Manual for available list of LVDH1 threshold settings.

Low-voltage detection (1.15 V power supply low-voltage detection)

(T<sub>A</sub>: Recommended operating conditions, V<sub>SS</sub> = AV<sub>SS</sub> = 0.0 V)

Parameter	Symbol	Pin Name	Conditions	Value			Unit	Remarks
				Min	Typ	Max		
Supply voltage range	V <sub>RDP12</sub>	VCC12	-	1.09	-	1.21	V	
Detection voltage (before trimming)*	V <sub>RDLBT</sub>	VCC12	*1 *2	0.7125	0.8125	0.9125	V	When power-supply voltage falls
Detection voltage (after trimming)	V <sub>RDLAT</sub>	VCC12	*1 *2	0.7841	0.8125	0.8410	V	When power-supply voltage falls Typ ±3.5 %
Hysteresis width	V <sub>RHYS</sub>	-	-	-	75	-	mV	When power-supply voltage rises
Low-voltage detection time	TRd	-	-	-	-	30	µs	

- \*1: If the power fluctuation time is less than the low-voltage detection time (TRd) and has passed the detection voltage range, the detection may occur or be canceled after the supply voltage has passed the detection voltage range.
- \*2: These LVD settings cannot be used to reliably generate a reset before voltage dips below minimum guaranteed MCU operation voltage, as these detection levels are below the minimum guaranteed MCU operation voltage (1.09 V).

**Notes:**

- The detection/release threshold values of LVDL2 channel is potentially below supply range defined in [9.1.2 Recommended Operating Condition](#).
- Please use this LVDL2 channel with your own risk.
- Please monitor the external power supplies on the PCB if needed.

## 9.1.4.12 Low Voltage Detection (Internal Voltage)

Low-voltage detection (internal low-voltage detection for LVDL0)

(T<sub>A</sub>: Recommended operating conditions, V<sub>SS</sub> = AV<sub>SS</sub> = 0.0 V)

Parameter	Symbol	Pin Name	Conditions	Value			Unit	Remarks
				Min	Typ	Max		
Supply voltage range	V <sub>RDP5</sub>	-	-	1.05	-	1.21	V	
Detection voltage	V <sub>RDL</sub>	-	*1 *2	0.75	0.85	0.95	V	When power-supply voltage falls
Hysteresis width	V <sub>RHYS</sub>	-	-	-	75	-	mV	When power-supply voltage rises
Low-voltage detection time	TR <sub>d</sub>	-	-	-	-	30	μs	*3

\*1: If the power fluctuation time is less than the low-voltage detection time (TR<sub>d</sub>) and has passed the detection voltage range, the detection may occur or be canceled after the supply voltage has passed the detection voltage range.

\*2: This LVD cannot be used to reliably generate a reset before voltage dips below minimum guaranteed MCU operation voltage, as these detection levels are below the minimum guaranteed MCU operation voltage (1.05 V).

\*3: After the brown-out event where the voltage level dips below the detection threshold for less than this time, the detection may occur or be canceled.

### Notes:

- The detection/release threshold values of LVDL0 channel is potentially below supply range defined in [9.1.2 Recommended Operating Condition](#).

Low-voltage detection (internal low-voltage detection for LVDL1)

(T<sub>A</sub>: Recommended operating conditions, V<sub>SS</sub> = AV<sub>SS</sub> = 0.0 V)

Parameter	Symbol	Pin Name	Conditions	Value			Unit	Remarks
				Min	Typ	Max		
Supply voltage range	V <sub>RDP5</sub>	-	-	1.05	-	1.21	V	
Detection voltage (before trimming)	V <sub>RDLBT</sub>	-	*1 *2	0.775	0.875	0.975	V	When power-supply voltage falls
Detection voltage (after trimming)	V <sub>RDLAT</sub>	-	*1 *2	0.844	0.875	0.906	V	When power-supply voltage falls Typ ±3.5 %
Hysteresis width	V <sub>RHYS</sub>	-	-	-	75	-	mV	When power-supply voltage rises
Low-voltage detection time	TR <sub>d</sub>	-	-	-	-	30	μs	*3

\*1: If the power fluctuation time is less than the low-voltage detection time (TR<sub>d</sub>) and has passed the detection voltage range, the detection may occur or be canceled after the supply voltage has passed the detection voltage range.

\*2: This LVD cannot be used to reliably generate a reset before voltage dips below minimum guaranteed MCU operation voltage, as these detection levels are below the minimum guaranteed MCU operation voltage (1.05 V).

\*3: After the brown-out event where the voltage level dips below the detection threshold for less than this time, the detection may occur or be canceled.

### Notes:

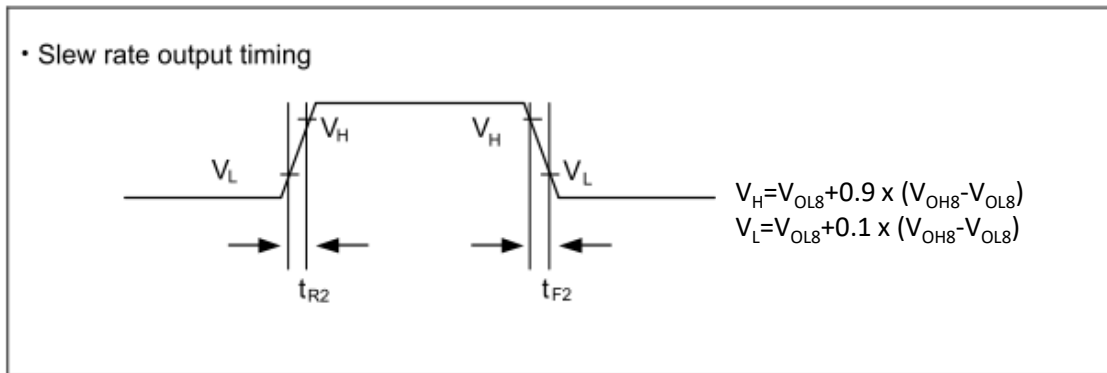
- The detection/release threshold values of LVDL1 channel is potentially below supply range defined in [9.1.2 Recommended Operating Condition](#).

## 9.1.4.13 High Current Output Slew Rate

 (T<sub>A</sub>: Recommended operating conditions,

 V<sub>CC5</sub>, V<sub>CC53</sub>, DV<sub>CC</sub> = 5.0 V ± 10 %, V<sub>CC3</sub> = 3.3 V ± 0.3 V, V<sub>CC12</sub> = 1.15 V ± 0.06 V, V<sub>SS</sub> = DV<sub>SS</sub> = AV<sub>SS</sub> = 0.0 V)

Parameter	Symbol	Pin Name	Conditions	Value			Unit	Remarks
				Min	Typ	Max		
Output rise / fall time	t <sub>R2</sub> , t <sub>F2</sub>	P1_17 to P1_31, P2_00 to P2_08	-	15	-	100	ns	Load capacitance 85 pF



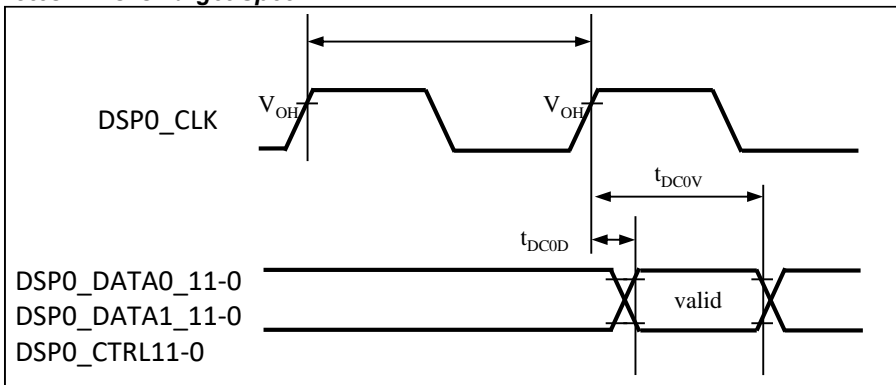
9.1.4.14 Display Controller

(1) Display Controller0 Timing (TTL Mode)

(TA: Recommended operating conditions, Vcc53 = 5.0 V ± 10 %, 3.3 V ± 0.3 V, Vss = DVss = AVss = 0.0 V)

Parameter	Symbol	Pin Name	Conditions	Value		Unit	Remarks
				Min	Max		
Clock Cycle	$t_{DC0CYC}$	DSP0_CLK	(CL = 20 pF, IOL = -15 mA, IOH = 15 mA),	25	-	ns	
Output delay from DSP0_CLK↑	$ t_{DC0D} $	DSP0_R7-0 DSP0_G7-0 DSP0_B7-0 DSP0_EN DSP0_HSYNC DSP0_VSYNC	(CL = 20 pF, IOL = -5 mA, IOH = 5 mA)	-	3.2	ns	
Output data valid time	$t_{DC0V}$	DSP0_R7-0 DSP0_G7-0 DSP0_B7-0 DSP0_EN DSP0_HSYNC DSP0_VSYNC		21.8	-	ns	$t_{DC0CYC} - 3.3 \text{ ns} + 0.1 \text{ ns}$

Notes: This is Target Spec.



## 9.1.4.15 External Bus Interface Timing

### Clock Output Timing

(T<sub>A</sub>: Recommended operating conditions, V<sub>CC53</sub> = 5.0 V ± 10 %, V<sub>SS</sub> = 0.0 V)  
 (External load capacitance 16 pF)

Parameter	Symbol	Pin Name	Conditions	Value		Unit	Remarks
				Min	Max		
Cycle time	t <sub>CYC</sub>	MCLK	2 mA is selected in ODR bit in PPC_PCFGR register.	62.5	-	ns	
Clock high width *1	t <sub>CHCL</sub>	MCLK		d <sub>H</sub> t <sub>CYC</sub> - 7	d <sub>H</sub> t <sub>CYC</sub> + 7	ns	
Clock low width *2	t <sub>CLCH</sub>	MCLK		d <sub>L</sub> t <sub>CYC</sub> - 7	d <sub>L</sub> t <sub>CYC</sub> + 7	ns	

\*1: If division-ratio is even value, d<sub>H</sub> is equivalent to 0.5.

Otherwise, d<sub>H</sub> is calculated as the following.

d<sub>H</sub> = The number rounding "division-ratio x 0.5" down to the nearest integer / division-ratio  
 division-ratio is multiplication value among SYSDIV bit, HPMDIV bit and EXTBUSDIV bit setting.

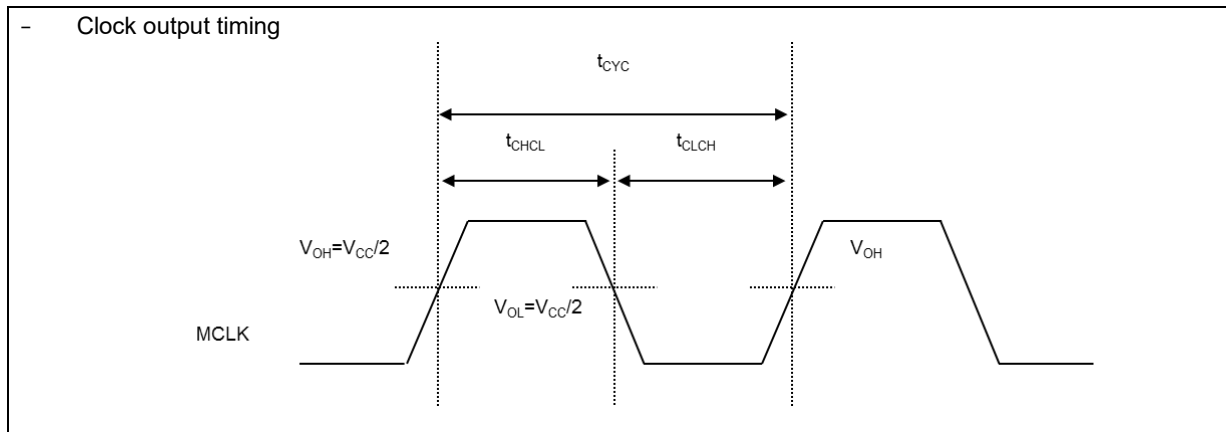
ex). Setting SYSDIV to 1-division, HPMDIV to 7-division, EXTBUSDIV to 1-division, d<sub>H</sub> is calculated as 0.429.

\*2: If division-ratio is even value, d<sub>L</sub> is equivalent to 0.5.

Otherwise, d<sub>L</sub> is calculated as the following.

d<sub>L</sub> = The number rounding "division-ratio x 0.5" up to the nearest integer / division-ratio  
 division-ratio is multiplication value among SYSDIV bit, HPMDIV bit and EXTBUSDIV bit setting.

ex). Setting SYSDIV to 1-division, HPMDIV to 7-division, EXTBUSDIV to 1-division, d<sub>L</sub> is calculated as 0.571.

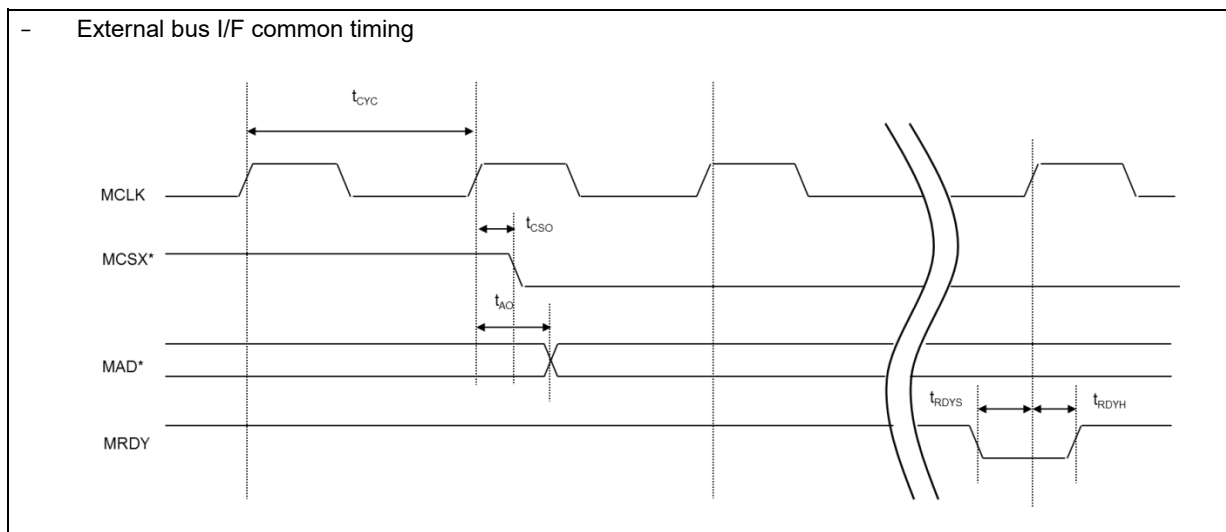


Common Timing between Read and Write

(TA: Recommended operating conditions, Vcc53 = 5.0 V ± 10 %, Vss = 0.0 V)  
 (External load capacitance 16 pF)

Parameter	Symbol	Pin Name	Conditions	Value		Unit	Remarks
				Min	Max		
Cycle time (without MRDY)	t <sub>CYC</sub>	MCLK	2 mA is selected in ODR bit in PPC_PCFGR register.	62.5	-	ns	
Cycle time (with MRDY)	t <sub>CYC</sub>	MCLK		62.5	-	ns	If using MRDY, set MCLK to 20 MHz or less.
CS delay time	t <sub>CSO</sub>	MCLK, MCSX0 to MCSX3		0.5	18	ns	
Address delay time	t <sub>AO</sub>	MCLK, MAD00 to MAD23		0.5	18	ns	
RDY setup time	t <sub>RDYS</sub>	MCLK, MRDY	"CMOS Schmitt input" and "Disable noise filter" are selected in PPC_PCFGR register.	21	-	ns	
RDY hold time	t <sub>RDYH</sub>	MCLK, MRDY	"CMOS Schmitt input" and "Disable noise filter" are selected in PPC_PCFGR register.	0	-	ns	

**Notes: This is Target Spec.**

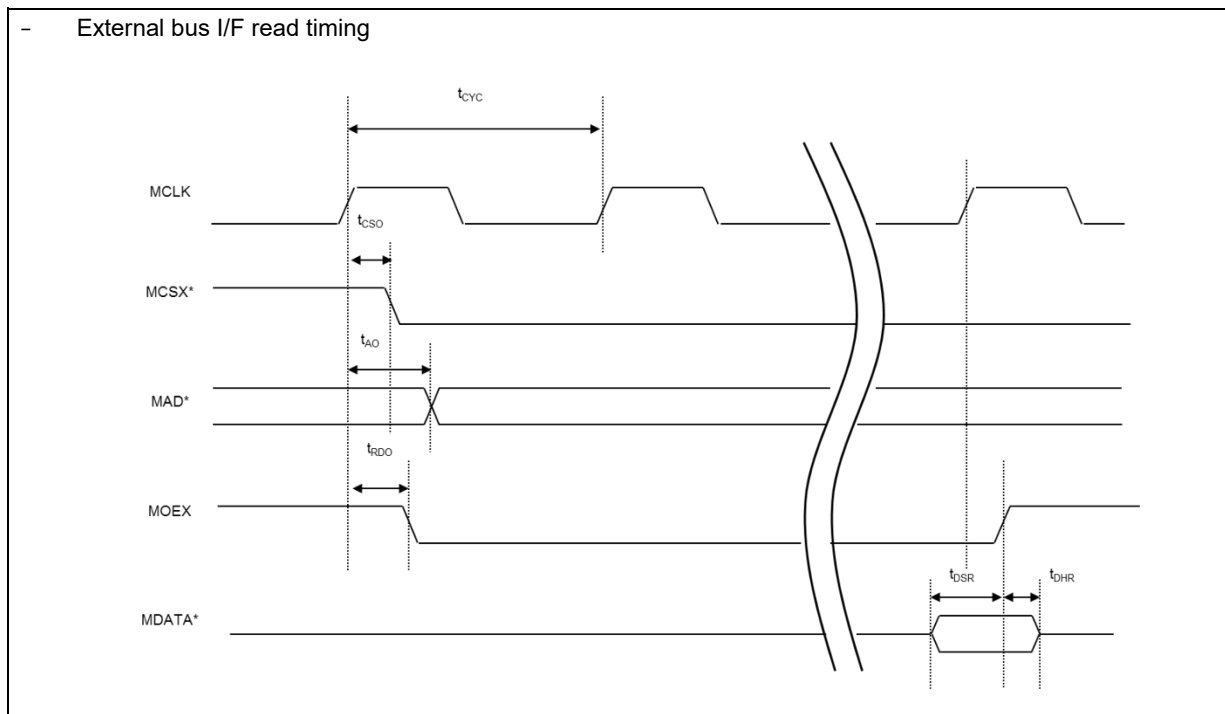


## Read Timing

(TA: Recommended operating conditions, Vcc53 = 5.0 V ± 10 %, Vss = 0.0 V)  
 (External load capacitance 16 pF)

Parameter	Symbol	Pin Name	Conditions	Value		Unit	Remarks
				Min	Max		
Data setup time	$t_{DSR}$	MOEX, MDATA00 to MDATA15	"CMOS Schmitt input" and "Disable noise filter" are selected in PPC_PCFG register.	$21+t_{cy}$ c	-	ns	
Data hold time	$t_{DHR}$	MOEX, MDATA00 to MDATA15		0	-	ns	
MOEX delay time	$t_{RDO}$	MCLK, MOEX	2 mA is selected in ODR bit in PPC_PCFG register.	0.5	18	ns	

**Notes: This is Target Spec.**



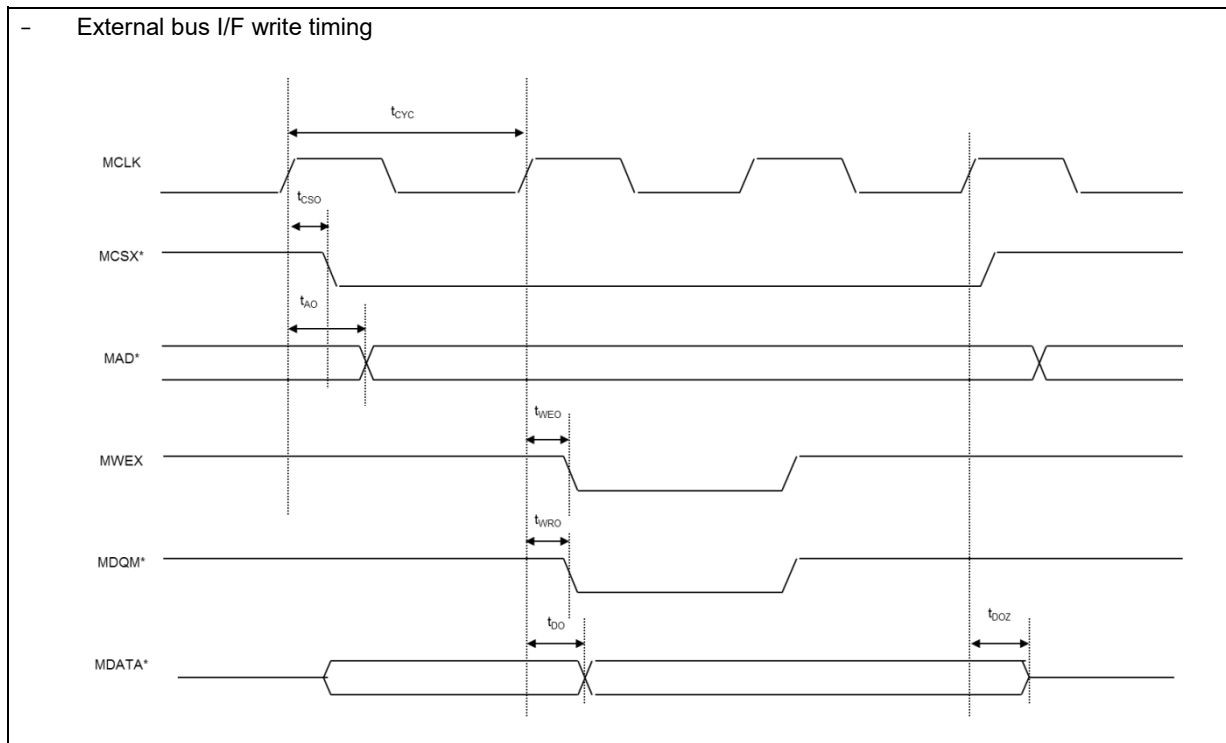


## Write Timing

(TA: Recommended operating conditions, Vcc53 = 5.0 V ± 10 %, Vss = 0.0 V)  
 (External load capacitance 16 pF)

Parameter	Symbol	Pin Name	Conditions	Value		Unit	Remarks
				Min	Max		
MWEX delay time	$t_{WEO}$	MCLK, MWEX	2 mA is selected in ODR bit in PPC_PCFGR register.	0.5	18	ns	
Byte mask delay time	$t_{WRO}$	MCLK, MDQM0 to MDQM1		0.5	18	ns	
Data delay time	$t_{DO}$	MCLK, MDATA00 to MDATA15		0.5	18	ns	
Data delay time (Hi-Z output)	$t_{DOZ}$	MCLK, MDATA00 to MDATA15		-	18	ns	

**Notes: This is Target Spec.**



## 9.1.4.16 DDR-HSSPI

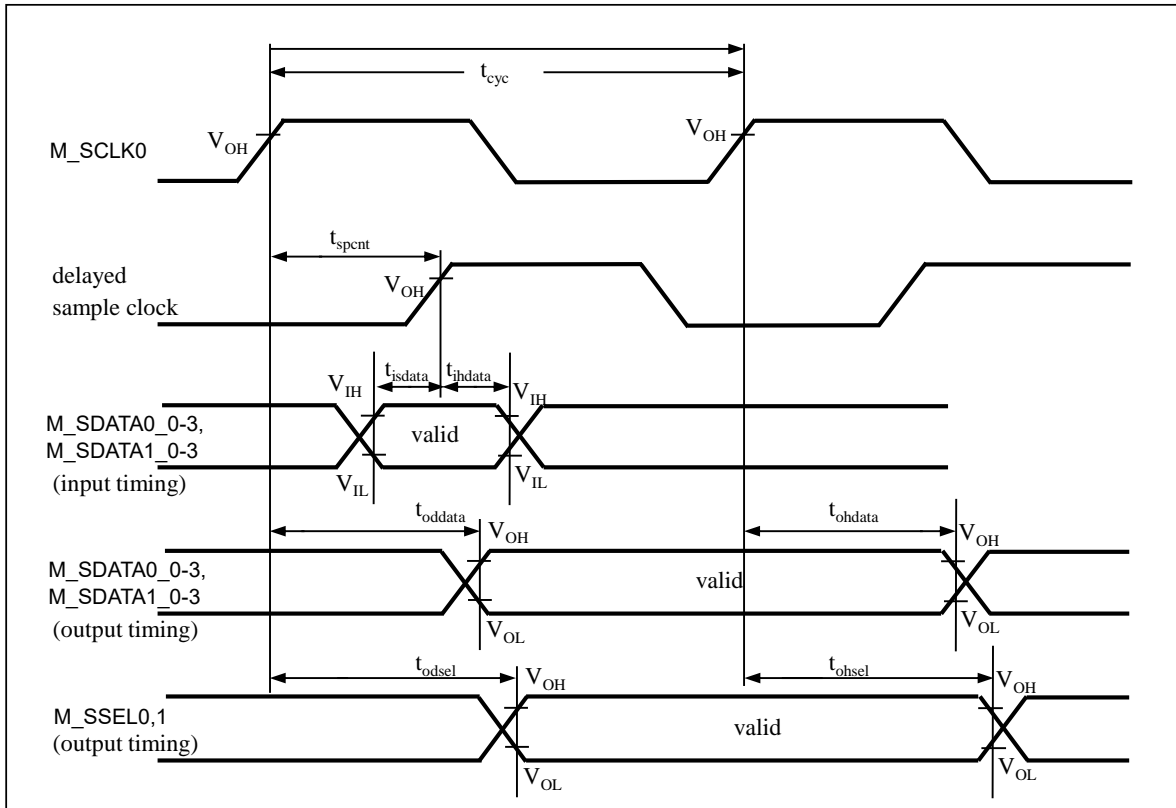
### (1) DDR-HSSPI Interface Timing (SDR Mode)

(TA: Recommended operating conditions, Vcc3 = 3.3 V ± 0.3 V, Vss = DVss = AVss = 0.0 V)

Parameter	Symbol	Pin Name	Conditions	Value		Unit	Remarks
				Min	Max		
HSSPI clock cycle	t <sub>cyc</sub>	M_SCLK0	(CL = 20 pF, I <sub>OL</sub> = -10 mA, I <sub>OH</sub> = 10 mA),	10	-	ns	
				20	-		when Quad Page Program
M_SCLK↑ -> delayed sample clock↑	t <sub>spcnt</sub>	-		0	31.5	ns	
M_SDATA -> M_SCLK↑ Input setup time	t <sub>isdata</sub>	M_SDATA0_0-3 M_SDATA1_0-3		*1	-	ns	
M_SCLK↑ -> M_SDATA Input hold time	t <sub>ihdata</sub>	M_SDATA0_0-3 M_SDATA1_0-3		*1	-	ns	
M_SCLK↑ -> M_SDATA Output delay time	t <sub>oddata</sub>	M_SDATA0_0-3 M_SDATA1_0-3		-	t <sub>cyc</sub> /2 + 2	ns	
M_SCLK↑ -> M_SDATA Output hold time	t <sub>ohdata</sub>	M_SDATA0_0-3 M_SDATA1_0-3		t <sub>cyc</sub> /2 - 3	-	ns	
M_SCLK↑ -> M_SSEL Output delay time	t <sub>odsel</sub>	M_SSEL0, 1		-	12.00+(SS 2CD+0.5)* t <sub>cyc</sub>	ns	
M_SCLK↑ -> M_SSEL Output hold time	t <sub>ohsel</sub>	M_SSEL0, 1		t <sub>cyc</sub> - 2	-	ns	

**Notes: This is Target Spec.**

- SS2CD [1:0] should be configured as 01, 10, or 11.
- For \*1, the delay of the delay sample clock can be configured (DLP function).



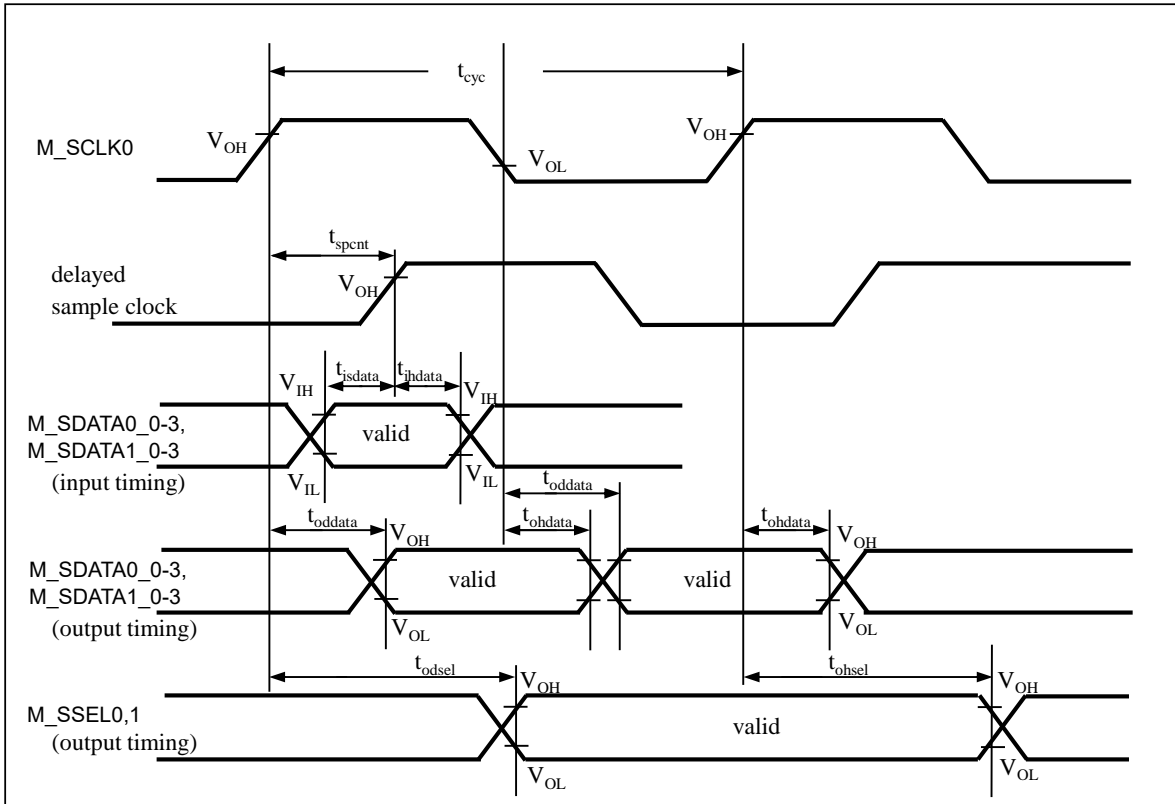
**(2) DDR-HSSPI Interface Timing (DDR Mode)**

(TA: Recommended operating conditions,  $V_{cc3} = 3.3\text{ V} \pm 0.3\text{ V}$ ,  $V_{ss} = DV_{ss} = AV_{ss} = 0.0\text{ V}$ )

Parameter	Symbol	Pin Name	Conditions	Value		Unit	Remarks
				Min	Max		
HSSPI clock cycle	$t_{cyc}$	M_SCLK0	(CL = 20 pF, $I_{OL} = -10\text{ mA}$ , $I_{OH} = 10\text{ mA}$ ),	12.5	-	ns	
M_SCLK $\uparrow$ -> delayed sample clock $\uparrow$	$t_{spcnt}$			0	31.5	ns	
M_SDAT0 -> M_SCLK $\uparrow$ Input setup time	$t_{isdata}$	M_SDAT0_0-3 M_SDAT1_0-3		*1	-	ns	
M_SCLK $\uparrow$ -> M_SDAT Input hold time	$t_{ihdata}$	M_SDAT0_0-3 M_SDAT1_0-3		*1	-	ns	
M_SCLK $\uparrow$ -> M_SDAT Output delay time	$t_{oddata}$	M_SDAT0_0-3 M_SDAT1_0-3		-	$t_{cyc}/4 + 1.5$	ns	
M_SCLK $\uparrow$ -> M_SDAT Output hold time	$t_{ohdata}$	M_SDAT0_0-3 M_SDAT1_0-3		$T_{cyc}/4 - 1.0$	-	ns	
M_SCLK $\uparrow$ -> M_SSEL Output delay time	$t_{odsel}$	M_SSEL0, 1		-	$15.75 + (SS2C D + 0.5) * t_{cyc}$	ns	
M_SCLK $\uparrow$ -> M_SSEL Output hold time	$t_{ohsel}$	M_SSEL0, 1		$0.75 * t_{cyc} - 2.0$	-	ns	

Notes: This is Target Spec.

- SS2CD [1:0] should be configured as 01, 10, or 11.
- For \*1, the delay of the delay sample clock can be configured (DLP function)



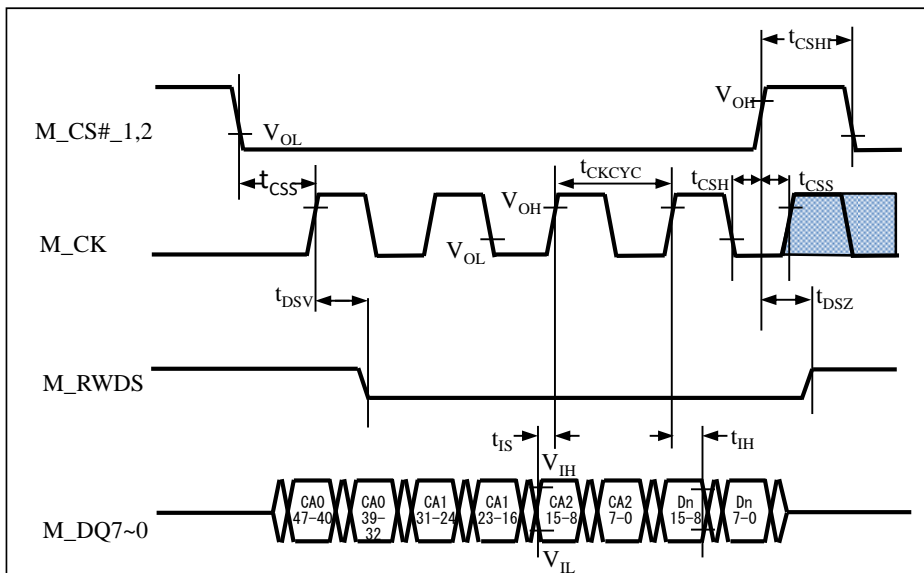
## 9.1.4.17 Hyper BUS

### (1) Hyper Bus Write Timing (HyperFlash)

(T<sub>A</sub>: Recommended operating conditions, V<sub>CC3</sub> = 3.3 V ± 0.3 V, V<sub>SS</sub> = DV<sub>SS</sub> = AV<sub>SS</sub> = 0.0 V)

Parameter	Symbol	Pin Name	Conditions	Value		Unit	Remarks
				Min	Max		
Hyper Bus clock cycle	t <sub>CKCYC</sub>	M_CK	(CL = 20 pF, I <sub>OL</sub> = -10 mA, I <sub>OH</sub> = 10 mA),	10.0	-	ns	
CS $\uparrow\downarrow$ -> CK $\uparrow$ Chip Select setup time	t <sub>CSS</sub>	M_CS#_1,2		t <sub>CKCYC</sub> - 2.0	-	ns	
DQ -> CK $\uparrow\downarrow$ Input setup time	t <sub>IS</sub>	M_DQ7-0		1.25	-	ns	
CK $\uparrow\downarrow$ -> DQ Input hold time	t <sub>IH</sub>	M_DQ7-0		1.25	-	ns	
CK $\downarrow$ -> CS $\uparrow$ Chip select hold time	t <sub>CSH</sub>	M_CS#_1,2		t <sub>CKCYC</sub> /2	-	ns	

**Notes: This is Target Spec**

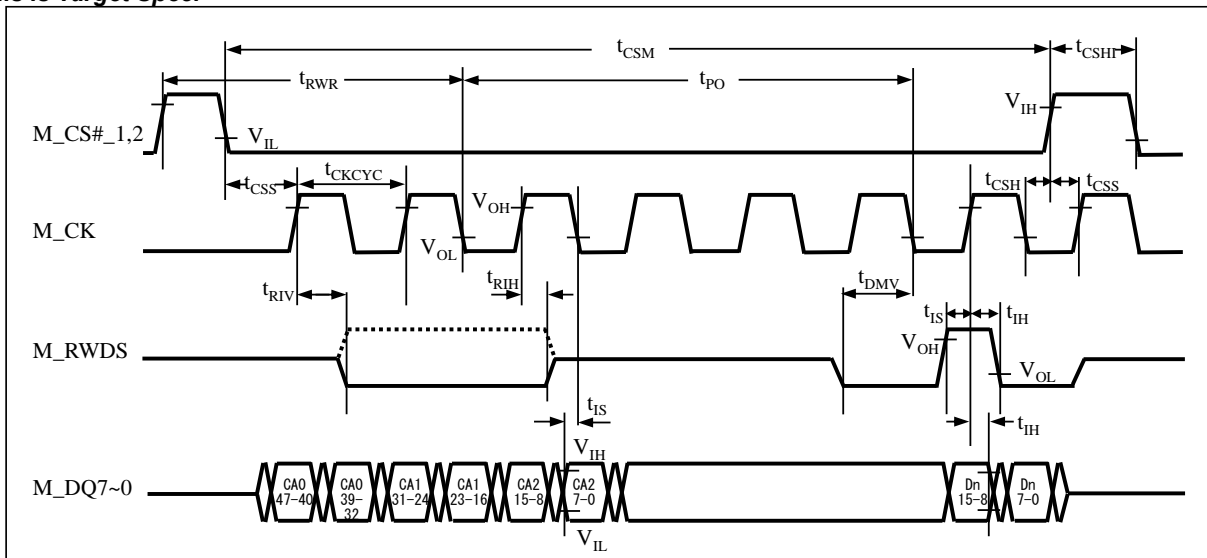


(2) Hyper Bus Write Timing (HyperRAM)

(TA: Recommended operating conditions, Vcc3 = 3.3 V ± 0.3 V, Vss = DVss = AVss = 0.0 V)

Parameter	Symbol	Pin Name	Conditions	Value		Unit	Remarks
				Min	Max		
Hyper Bus clock cycle	t <sub>CKCYC</sub>	M_CK	(CL = 20 pF, I <sub>OL</sub> = -10 mA, I <sub>OH</sub> = 10 mA),	10.0	-	ns	
CS↑↓ -> CK↑ Chip Select setup time	t <sub>CSS</sub>	M_CS#_1,2		t <sub>CKCYC</sub> - 2.0	-	ns	
DQ -> CK↑↓ Input setup time	t <sub>IS</sub>	M_DQ7-0		1.25	-	ns	
CK↑↓ -> DQ Input hold time	t <sub>IH</sub>	M_DQ7-0		1.25	-	ns	
CK↓ -> CS↑ Chip select hold time	t <sub>CSH</sub>	M_CS#_1,2		t <sub>CKCYC</sub> /2	-	ns	
RWDS↓-> CK↓ Data Mask Valid	t <sub>DMV</sub>	M_RWDS		1	-	ns	
CK↑ -> RWDS↑↓ Refresh Indicator Valid	t <sub>RIV</sub>	M_RWDS		-	6	ns	
CK↑ -> RWDS (Hi-z) Refresh Indicator Hold	t <sub>RIH</sub>	M_RWDS		0	-	ns	

Notes: This is Target Spec.

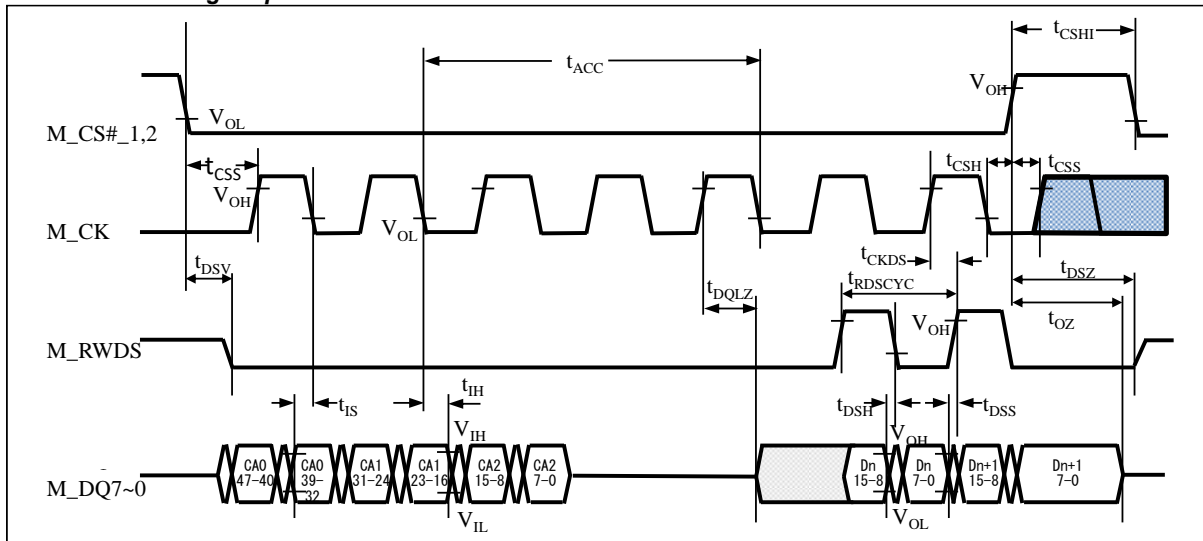


### (3) Hyper Bus Read Timing (HyperFlash)

(TA: Recommended operating conditions, Vcc3 = 3.3 V ± 3.3 V, Vss = DVss = AVss = 0.0 V)

Parameter	Symbol	Pin Name	Conditions	Value		Unit	Remarks
				Min	Max		
Hyper Bus clock cycle	$t_{RDSCYC}$	M_CK	(CL = 20 pF, IOL = -10 mA, IOH = 10 mA),	10.0	-	ns	
CS $\uparrow\downarrow$ -> CK $\uparrow$ Chip Select setup time	$t_{CSS}$	M_CS#_1,2		$t_{RDSCYC} - 2.0$	-	ns	
DQ -> CK $\uparrow\downarrow$ Setup time	$t_{IS}$	M_DQ7-0		1.25	-	ns	
CK $\uparrow\downarrow$ -> DQ Hold time	$t_{IH}$	M_DQ7-0		1.25	-	ns	
CK $\downarrow$ -> CS $\uparrow$ Chip select hold time	$t_{CSH}$	M_CS#_1,2		$t_{RDSCYC} / 2$	-	ns	
RDS $\uparrow\downarrow$ > DQ Setup time	$t_{DSS}$	M_DQ7-0		-0.8	-	ns	
RDS $\uparrow\downarrow$ > DQ Hold time	$t_{DSH}$	M_DQ7-0		-0.8	-	ns	

**Notes: This is Target Spec.**

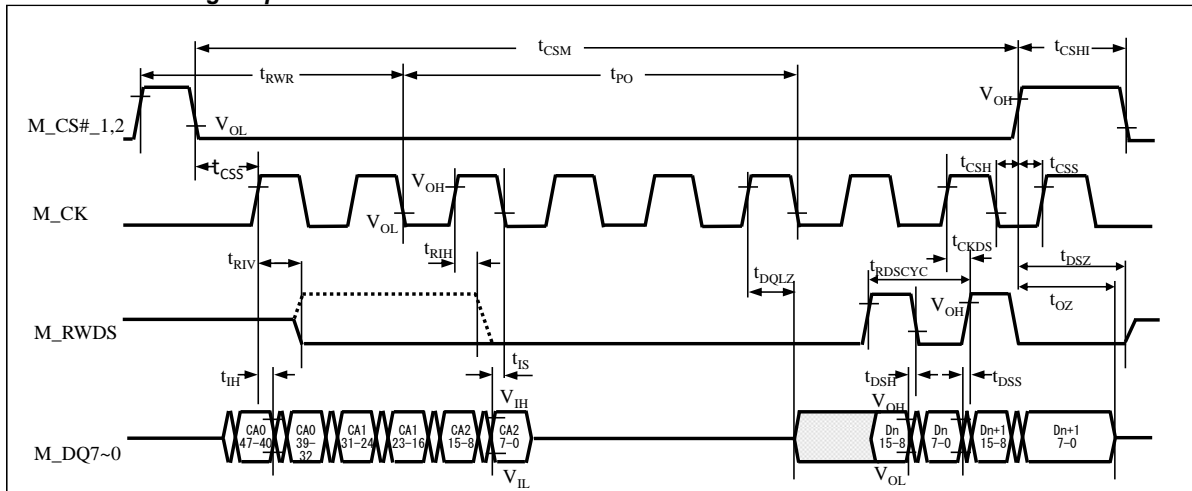


## (4) Hyper Bus Read Timing (HyperRAM)

(TA: Recommended operating conditions, Vcc3 = 3.3 V ± 0.3 V, Vss = DVss = AVss = 0.0 V)

Parameter	Symbol	Pin Name	Conditions	Value		Unit	Remarks
				Min	Max		
Hyper Bus clock cycle	$t_{RDSCYC}$	M_CK	(CL = 20 pF, IOL = -10 mA, IOH = 10 mA),	10.0	-	ns	
CS $\uparrow$ → CK $\uparrow$ Chip Select setup time	$t_{CSS}$	M_CS#_1,2		$t_{RDSCYC} - 2.0$	-	ns	
DQ → CK $\downarrow$ Setup time	$t_{IS}$	M_DQ7-0		1.25	-	ns	
CK $\downarrow$ → DQ Hold time	$t_{IH}$	M_DQ7-0		1.25	-	ns	
CK $\downarrow$ → CS $\uparrow$ Chip select hold time	$t_{CSH}$	M_CS#_1,2		$t_{RDSCYC} / 2$	-	ns	
RWDS $\uparrow$ → DQ (valid) Setup time	$t_{DSS}$	M_DQ7-0		-0.8	-	ns	
RWDS $\uparrow$ → DQ (invalid) Hold time	$t_{DSH}$	M_DQ7-0		-0.8	-	ns	
CK $\uparrow$ → RWDS $\uparrow$ Refresh Indicator Valid	$t_{RIV}$	M_RWDS		-	6	ns	
CK $\uparrow$ → RWDS (Hi-Z) Refresh Indicator Hold	$t_{RIH}$	M_RWDS		0	-	ns	

**Notes: This is Target Spec.**





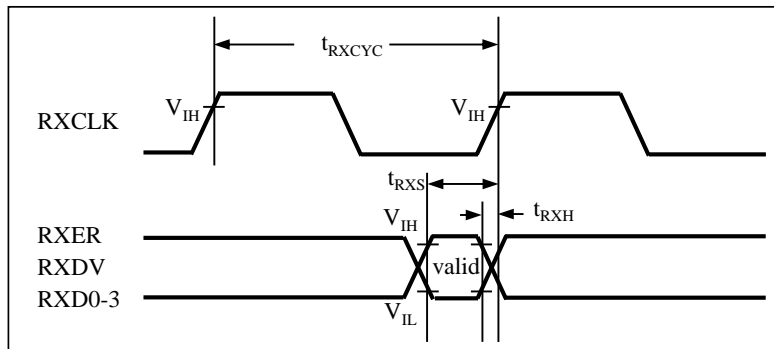
9.1.4.18 Ethernet AVB

(1) Ethernet Receive Timing

(T<sub>A</sub>: Recommended operating conditions, V<sub>cc53</sub> = V<sub>cc3</sub> = 3.3 V ± 0.3 V, V<sub>ss</sub> = DV<sub>ss</sub> = AV<sub>ss</sub> = 0.0 V)

Parameter	Symbol	Pin Name	Conditions	Value		Unit	Remarks
				Min	Max		
RXCLK cycle	t <sub>RXCYC</sub>	RXCLK	-	40.0	-	ns	-
RX setup time	t <sub>RXS</sub>	RXER RXDV RXD0-3		10.0	-	ns	t <sub>RXCYC</sub> -30 ns
RX hold time	t <sub>RXH</sub>	RXER RXDV RXD0-3		0	-	ns	-

Notes: This is Target Spec.

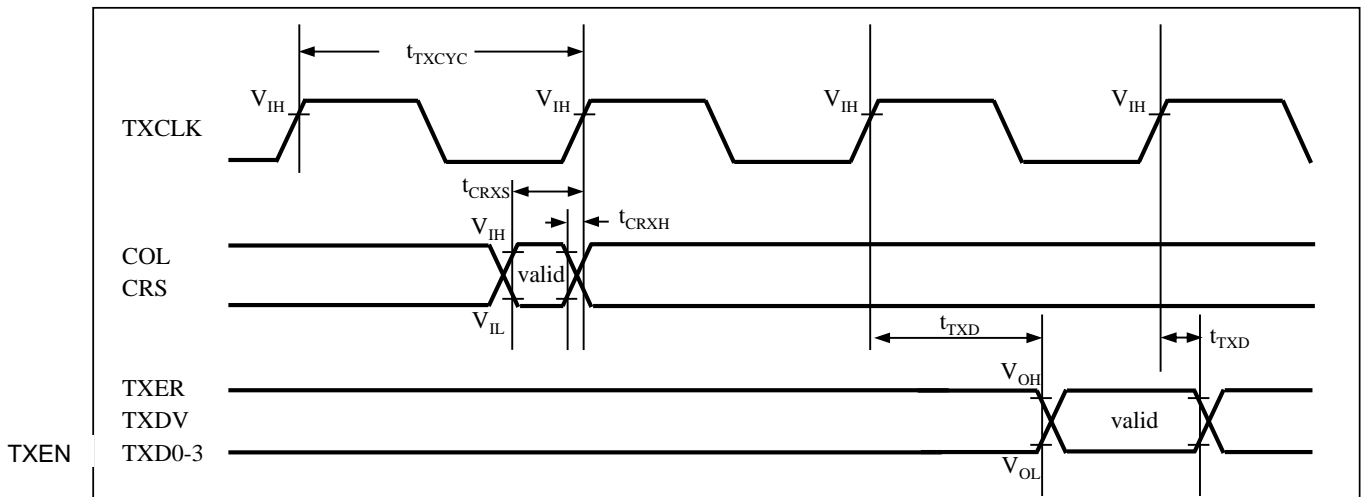


**(2) Ethernet Transmit Timing**

(T<sub>A</sub>: Recommended operating conditions, V<sub>cc3</sub> = V<sub>cc3</sub> = 3.3 V ± 0.3 V, V<sub>ss</sub> = DV<sub>ss</sub> = AV<sub>ss</sub> = 0.0 V)

Parameter	Symbol	Pin Name	Conditions	Value		Unit	Remarks
				Min	Max		
TXCLK cycle	t <sub>TXCYC</sub>	TXCLK	(CL = 20 pF, I <sub>OL</sub> = -5 mA, I <sub>OH</sub> = 5 mA),	40.0	-	ns	-
COL/CRS input setup time	t <sub>CRXS</sub>	COL CRS		12.0	-	ns	-
COL/CRS input hold time	t <sub>CRXH</sub>	COL CRS		0.5	-	ns	-
Tx delay time	t <sub>TXD</sub>	TXER TXEN TXD0-3		0.5	25	ns	-

**Notes: This is Target Spec.**

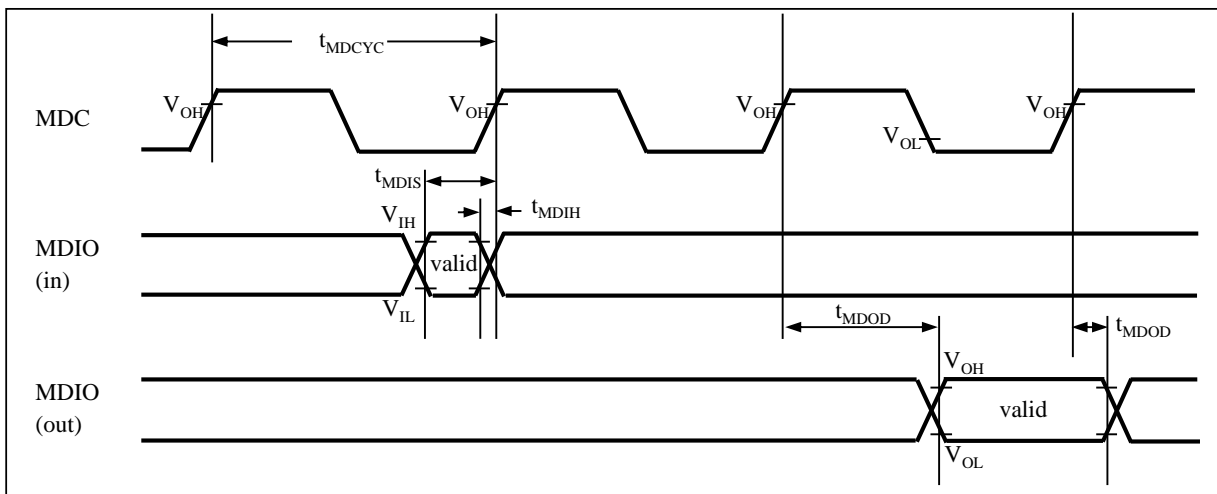


**(3) MDIO Timing**

(T<sub>A</sub>: Recommended operating conditions, V<sub>cc3</sub> = V<sub>cc3</sub> = 3.3 V ± 0.3 V, V<sub>ss</sub> = DV<sub>ss</sub> = AV<sub>ss</sub> = 0.0 V)

Parameter	Symbol	Pin Name	Conditions	Value		Unit	Remarks
				Min	Max		
MDC cycle	t <sub>MDCYC</sub>	MDC	(CL = 20 pF, I <sub>OL</sub> = -5 mA, I <sub>OH</sub> = 5 mA),	400.0	-	ns	-
MDIO input setup time	t <sub>MDIS</sub>	MDIO		100.0	-	ns	
MDIO input hold time	t <sub>MDIH</sub>	MDIO		0.0	-	ns	
MDIO output delay time	t <sub>MDOD</sub>	MDIO		10.0	190.0	ns	

**Notes: This is Target Spec.**



## 9.1.4.19 MediaLB

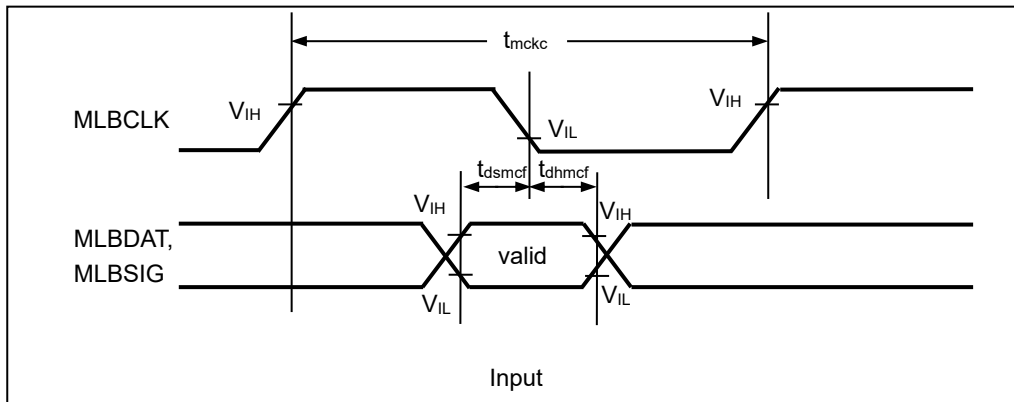
### (1) MediaLB Input Timing

(T<sub>A</sub>: Recommended operating conditions, V<sub>CC3</sub> = 3.3 V ± 0.3 V, V<sub>SS</sub> = DV<sub>SS</sub> = AV<sub>SS</sub> = 0.0 V)

Parameter	Symbol	Pin Name	Conditions	Value		Unit	Remarks
				Min	Max		
MLBCLK cycle	t <sub>mckc</sub>	MLBCLK		40.0	-	ns	
MLBSIG, MLBDAT Input setup	t <sub>dsacf</sub>	MLBSIG MLBDAT	-	1.0	-	ns	-
MLBSIG, MLBDAT Input hold	t <sub>dhacf</sub>	MLBSIG MLBDAT		4.0	-	ns	

**Notes: This is Target Spec.**

- CLK\_HAPP1B0 (internal) frequency > MLBCLK (external) frequency



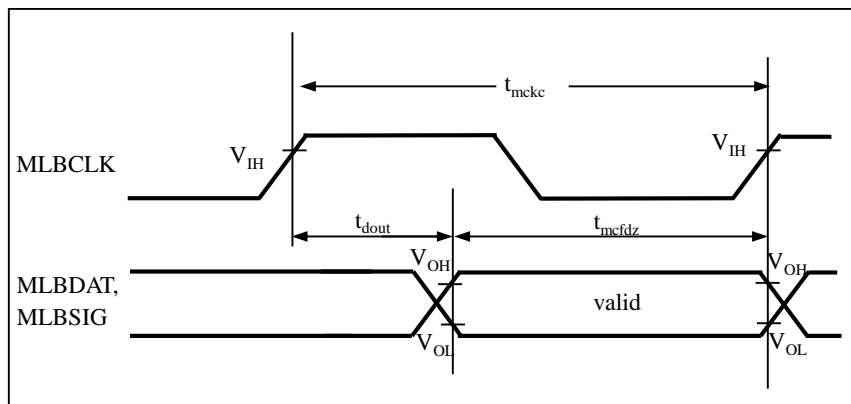
### (2) MediaLB Output Timing

(T<sub>A</sub>: Recommended operating conditions, V<sub>CC3</sub> = 3.3 V ± 0.3 V, V<sub>SS</sub> = DV<sub>SS</sub> = AV<sub>SS</sub> = 0.0 V)

Parameter	Symbol	Pin Name	Conditions	Value		Unit	Remarks
				Min	Max		
MLBCLK cycle	t <sub>mckc</sub>	MLBCLK		40.0	-	ns	-
MLBSIG, MLBDAT output stop	t <sub>mcfdz</sub>	MLBSIG MLBDAT	(CL = 20 pF, I <sub>OL</sub> = -6 mA, I <sub>OH</sub> = 6 mA),	26.5	-	ns	t <sub>mckc</sub> - t <sub>dout</sub>
MLBSIG, MLBDAT output delay	t <sub>dout</sub>	MLBSIG MLBDAT		0	13.5	ns	-

**Notes: This is Target Spec.**

- CLK\_HAPP1B0 (internal) frequency > MLBCLK (external) frequency



## 9.1.4.20 Port Noise Filter

 (T<sub>A</sub>: Recommended operating conditions, V<sub>CC5</sub>, V<sub>CC53</sub>, DV<sub>CC5</sub> = 5.0 V ± 10 %, V<sub>SS</sub> = DV<sub>SS</sub> = AV<sub>SS</sub> = 0.0 V)

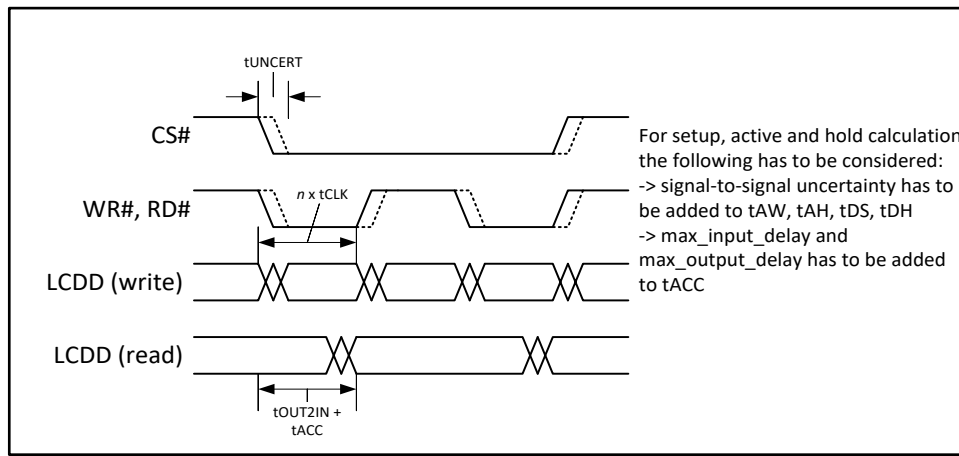
Parameter	Symbol	Pin Name	Conditions	Value		Unit	Remarks
				Min	Max		
Width for input removal	-	ALL GPIO	-	-	17	ns	-

\* Input pulse width less than at least 17 ns is removed when Port noise filter is enabled.

## 9.1.4.21 LCD Bus I/F

(T<sub>A</sub>: Recommended operating conditions, V<sub>CC53</sub> = 5.0 V ± 10 % / 3.3 V ± 0.3 V, V<sub>SS</sub> = 0.0 V, V<sub>CC12</sub> = 1.15 V ± 0.06 V)

Parameter	Symbol	Pin Name	Conditions	Value		Unit	Remarks
				Min	Max		
Clock cycle time	t <sub>CLK</sub>	WR#, RD#	(CL = 20 pF, I <sub>OL</sub> = -5 mA, I <sub>OH</sub> = 5 mA),	12.5	-	ns	-
Signal-to-Signal uncertainty	t <sub>UNCERT</sub>	CS#		-	5.0	ns	-
Output to input duration	t <sub>OUT2IN</sub>	LCDD0-17		-	25.0	ns	-



### Note:

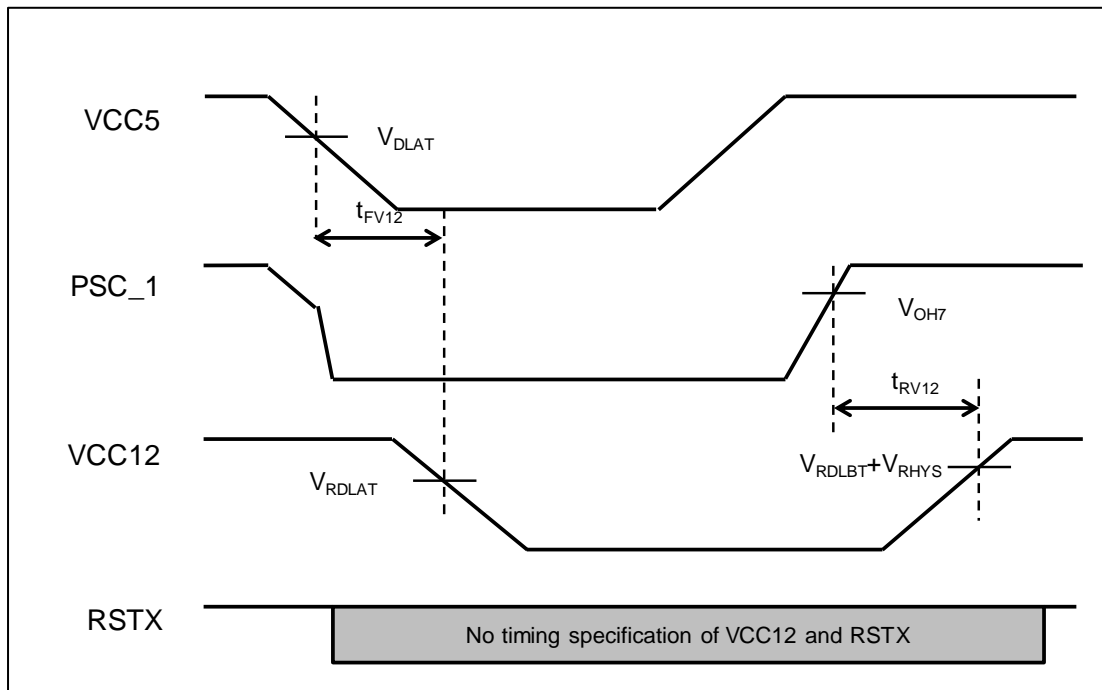
- In order to calculate interface timing, refer to the LCD controller specification of the external display for the required AC characteristics and S6J3300 Series Hardware Manual.

## 9.1.4.22 Power and Reset Sequence

VCC5 and VCC12 sequence

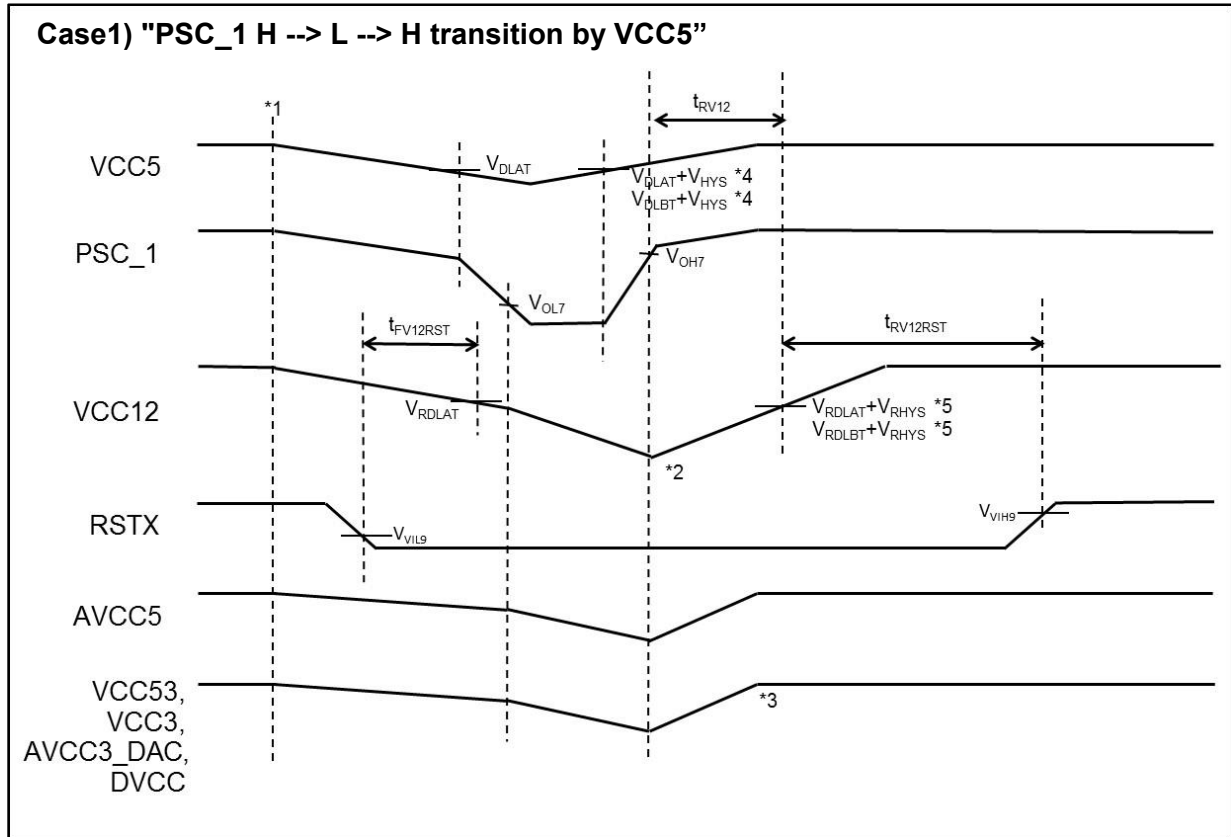
(T<sub>A</sub>: Recommended operating conditions, V<sub>SS</sub> = 0.0 V)

Parameter	Symbol	Pin Name	Conditions	Value		Unit	Remarks
				Min	Max		
Wait time from LVDH1 level detection to falling VCC12	t <sub>FV12</sub>	VCC12	-	0.6	-	ms	-
VCC12 stabilization time during power-on	t <sub>RV12</sub>	VCC12	-	-	14.2	ms	-



### Note:

- V<sub>DLAT</sub>, V<sub>RDLAT</sub>, V<sub>RDLBT</sub> and V<sub>RHYS</sub> are referred to "9.1.4.11 Low Voltage Detection (External Voltage)". V<sub>OH7</sub> is referred to "9.1.3 DC Characteristics".
- LVDH1 reset need to be "always enable". For details, see the Traveo™ Platform Hardware Manual.
- The above sequence needs not to be applied in the following cases the application enters PSS mode: "VCC12 is controlled by PSC\_1 at entry and exit from PSS mode" (Normal Sequence).


**Note:**

- RSTX controlled by VCC5.
- VCC12 and AVCC5 controlled by PSC\_1.
- VCC53, VCC3, AVCC3\_DAC and DVCC controlled by PSC\_1. Can be controlled by VCC5 GPIO also.
- VDLAT, VDLBT and VHYS are referred to "9.1.4.11 Low Voltage Detection (External Voltage)".  
VRDLAT, VRDLBT and VRHYS are referred to "9.1.4.12 Low Voltage Detection (Internal Voltage)".  
VOH7, VIL9 and VIH9 are referred to "9.1.3 DC Characteristics".  
 $t_{RV12}$ ,  $t_{FV12RST}$  and  $t_{RV12RST}$  are referred to "9.1.4.22 Power and Reset Sequence".

\*1: Battery Disconnect: All supplies fall together.

\*2: VCC12 can be fully depleted or not full depleted.

\*3: DVCC, VCC53 and VCC3 can start before or after VCC12.

\*4: VCC5 is higher than level detection voltage:  $V_{DLAT}+V_{HYS}$

VCC5 is lower than level detection voltage:  $V_{DLBT}+V_{HYS}$

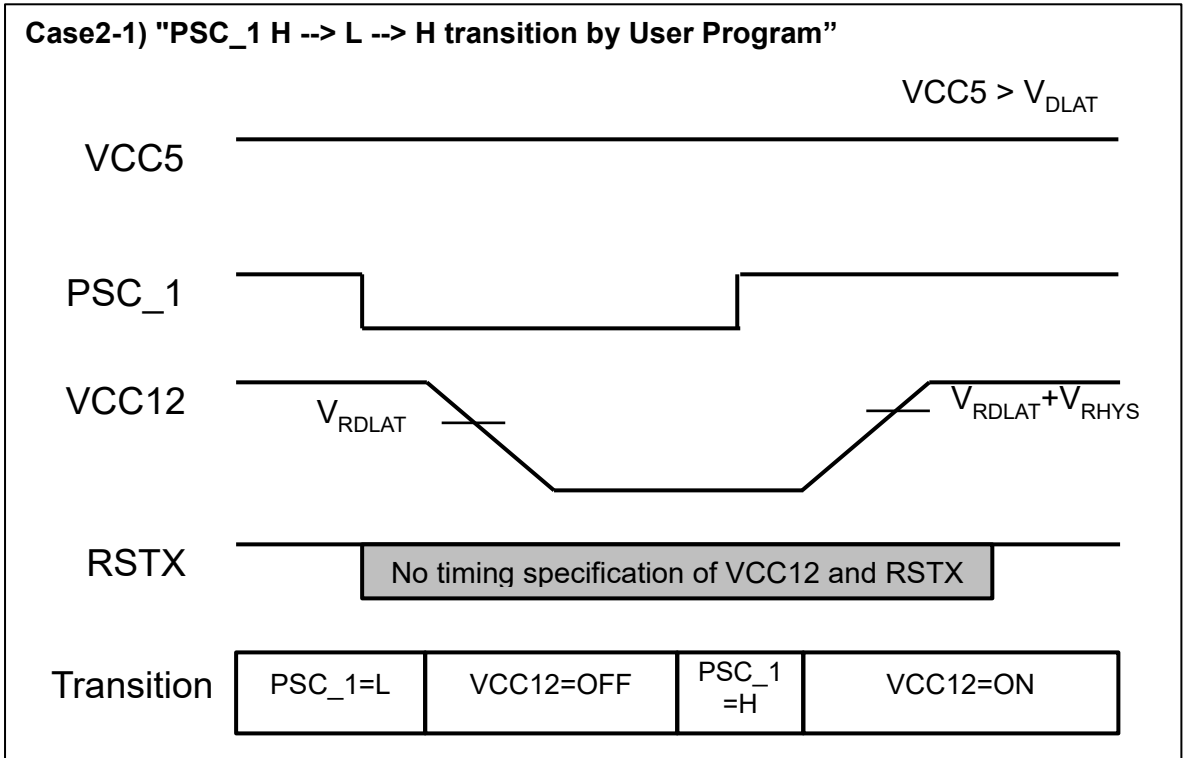
VDLAT, VDLBT and VHYS are referred to "9.1.4.11 Low Voltage Detection (External Voltage)".

\*5: VCC5 is higher than level detection voltage:  $V_{RDLAT}+V_{RHYS}$

VCC5 is lower than level detection voltage:  $V_{RDLBT}+V_{RHYS}$

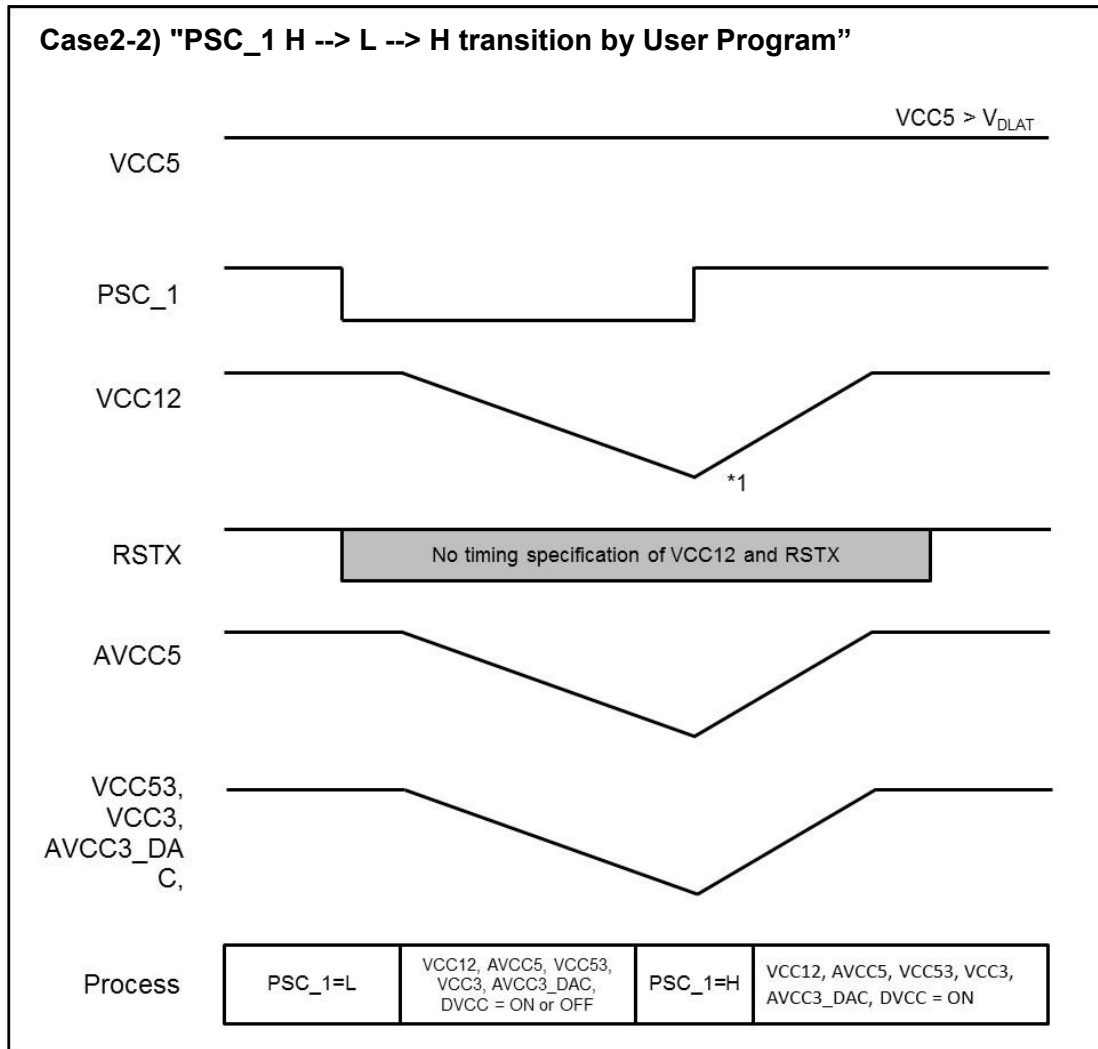
VRDLAT, VRDLBT and VRHYS are referred to "9.1.4.11 Low Voltage Detection (External Voltage)".





**Note:**

- VCC12 controlled by PSC\_1.
- VCC12 can be fully deplete



**Note:**

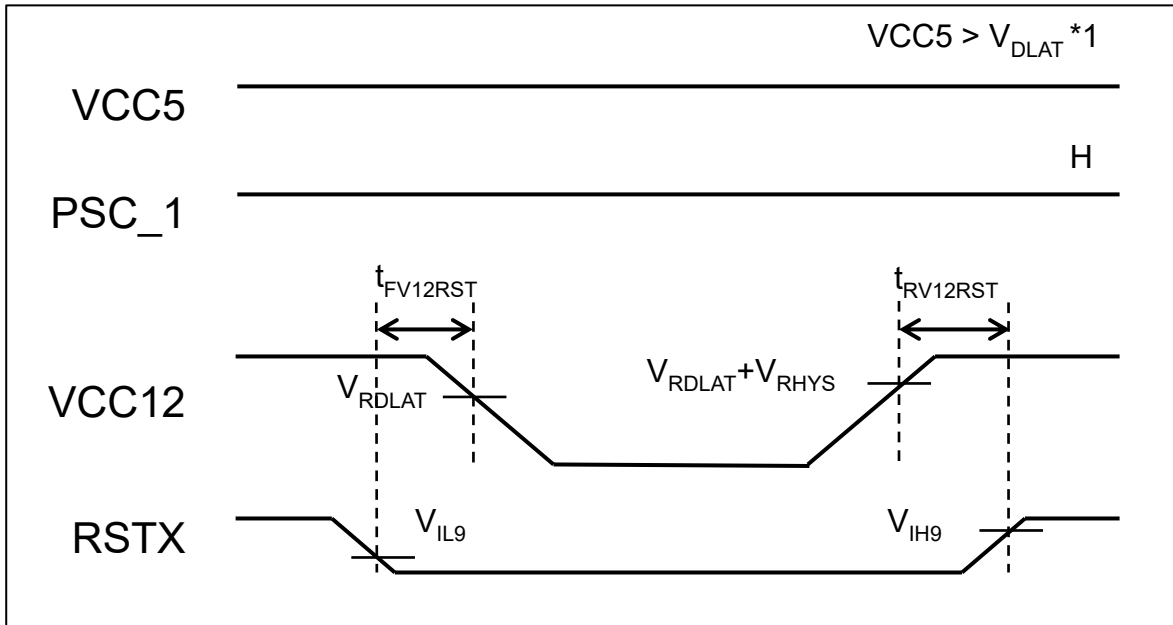
- VCC12 and AVCC5 controlled by PSC\_1.
- VCC53, VCC3, AVCC3\_DAC and DVCC controlled by PSC\_1. Can be controlled by VCC5 GPIO also.

\*1: VCC12 can be fully depleted or not full depleted.

## VCC12 and RSTX Sequence

(T<sub>A</sub>: Recommended operating conditions, V<sub>SS</sub> = 0.0 V)

Parameter	Symbol	Pin Name	Conditions	Value		Unit	Remarks
				Min	Max		
RSTX -> VCC12 fall interval time	t <sub>FV12RST</sub>	VCC12, RSTX	-	5	-	us	-
VCC12 -> RSTX rise interval time	t <sub>RV12RST</sub>	VCC12, RSTX		35	-	us	-



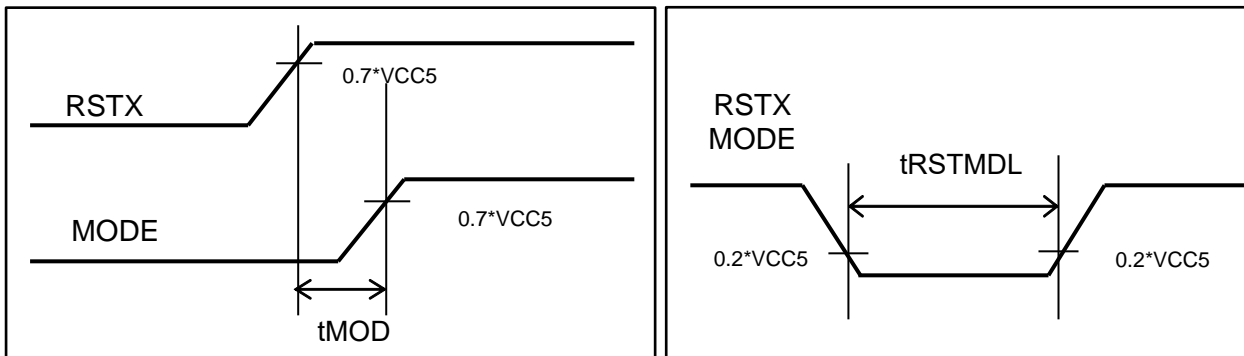
**Note:**

- If the sequence given in "VCC5 and VCC12 sequence" cannot be applied, this sequence can be applied.
- VDLAT, VRDLAT, VRDLAT and VRHYS are referred to "9.1.4.11 Low Voltage Detection (External Voltage)". VIL9 and VIH9 is referred to "9.1.3 DC Characteristics".
- This sequence is applied in case of VCC12 power on/off and assertion of RSTX is controlled by application.
- This sequence is applied under the condition VCC5 > VDLAT and PSC\_1 = H.

## RSTX and MODE Sequence

(T<sub>A</sub>: Recommended operating conditions, V<sub>CC5</sub> = 5.0 V ± 10 % / 3.3 V ± 0.3 V, V<sub>SS</sub> = 0.0 V)

Parameter	Symbol	Pin Name	Conditions	Value		Unit	Remarks
				Min	Max		
RSTX ↑ -> MODE ↑ delay time	tMOD	RSTX, MODE	-	-5	5	ns	-
Reset and mode input time	tRSTMDL	RSTX, MODE	-	10	-	us	-
Width for reset and mode input removal				1	-	us	-



### Note:

- If the sequence given in "[VCC5 and VCC12 sequence](#)" and "[VCC12 and RSTX Sequence](#)" cannot be applied, this sequence can be applied.
- Connect RSTX signal and MODE signal outside of the MCU and shorten the trace length between MCU and these two signal lines.
- The following assumptions are made with regard to the workaround described above.
  1. After the reset the MCU state is equivalent to the "cold start state" usually reached by power-on-reset.
  2. Debugger interface and PC writer interface are not enabled.
  3. The RAM retention cannot be guaranteed when applying this workaround
  4. Pin PSC\_1 will be driven low while RSTX is active (RSTX at low level)

## 9.1.5 A/D Converter

### 9.1.5.1 Electrical Characteristics

(T<sub>A</sub>: Recommended operating conditions, V<sub>CC5</sub> = 5.0 V ± 10 %, V<sub>CC12</sub> = 1.15 V ± 0.06 V, V<sub>SS</sub> = AV<sub>SS</sub> = 0.0 V)

Parameter	Symbol	Pin Name	Conditions			Unit	Remarks
			Min	Typ	Max		
Resolution	-	-	-	-	12	bit	-
Total Error	-	-	-	-	±12 <sup>*6</sup>	LSB	<sup>*3</sup>
			-	-	±15 <sup>*7</sup>	LSB	-
Integral Non linearity	-	-	-	-	±4.0	LSB	<sup>*4</sup>
Differential Non linearity	-	-	-	-	±1.9	LSB	<sup>*4</sup>
Zero transition voltage	V <sub>ZT</sub>	AN0 to AN63	AVRL -11.5LSB <sup>*6</sup>	-	AVRL +12.5LSB <sup>*6</sup>	V	<sup>*5</sup>
			AVRL -14.5LSB <sup>*7</sup>	-	AVRL +15.5LSB <sup>*7</sup>	V	
Full-scale transition voltage	V <sub>FST</sub>	AN0 to AN63	AVRH -13.5LSB <sup>*6</sup>	-	AVRH +10.5LSB <sup>*6</sup>	V	-
			AVRH -16.5LSB <sup>*7</sup>	-	AVRH +13.5LSB <sup>*7</sup>	V	-
Sampling time	t <sub>SMP</sub>	-	0.3	-	-	µs	<sup>*1</sup>
Compare time	t <sub>CMP</sub>	-	0.8	-	26	µs	<sup>*1</sup>
A/D conversion time	t <sub>CNV</sub>	-	1.1	-	-	µs	<sup>*1</sup>
Resumption Time	-	-	-	-	1	µs	-
Analog port input current	I <sub>AIN</sub>	AN0 to AN30, AN32 to AN38	-1.0	-	1.0	µA	AV <sub>SS</sub> ≤ V <sub>AIN</sub> ≤ AV <sub>CC5</sub>
		AN31, AN39 to AN63	-2.0	-	2.0	µA	
Analog input voltage	V <sub>AIN</sub>	AN0 to AN63	AVRL	-	AVRH	V	-
Reference voltage	AVRH	AVRH5	4.5 <sup>*6</sup>	-	5.5 <sup>*6</sup>	V	AV <sub>CC5</sub> ≥ AVRH
			3.0 <sup>*7</sup>	-	3.6 <sup>*7</sup>	V	
	AVRL	AVRL5/AVSS	-	0.0	-	V	-
Power supply current	I <sub>A</sub>	AVCC5	-	500	900 (Target)	µA	1 unit
	I <sub>AH</sub>		-	1.0	200 (Target)	µA	<sup>*2</sup>
	I <sub>R</sub>	AVRH5	-	1.0	3.5 (Target) <sup>*6</sup>	mA	1 unit
			-	1.0	2.5 (Target) <sup>*7</sup>	mA	1 unit
	I <sub>RH</sub>	-	-	-	9.0 (Target)	µA	<sup>*2</sup>
Variation between channels	-	AN0 to AN63	-	-	4.0	LSB	-

\*1: Time per channel

\*2: Definition of the power supply current (when V<sub>CC5</sub> = AV<sub>CC5</sub> = 5.0 V) while the A/D converter is not operating and in stop mode

\*3: Total Error is a comprehensive static error that includes the linearity after trimming by software. 1 LSB = (AVRH-AVRL)/4096

\*4: 1 LSB = (VFST-VZT)/4094

\*5: 1 LSB = (AVRH-AVRL)/4096

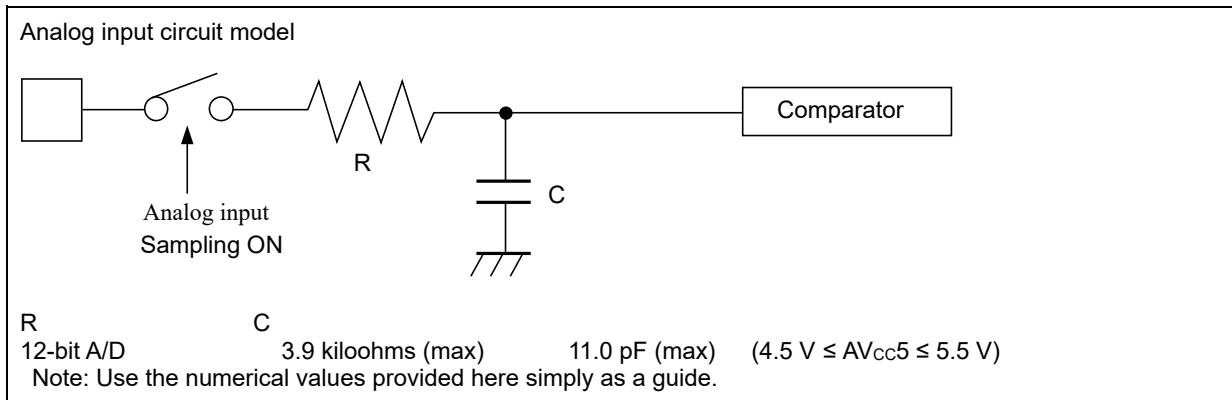
\*6: For S6J33xxxSx or S6J33xxxUx or S6J33xxxTx or S6J33xxxVx option.

\*7: For S6J33xxxAx or S6J33xxxBx or S6J33xxxCx or S6J33xxxDx or S6J33xxxEx or S6J33xxxFx or S6J33xxxGx or S6J33xxxHx option.

9.1.5.2 Notes on A/D Converters

**About the Output Impedance of an External Circuit for Analog Input**

When the external impedance is too high, the analog voltage sampling time may become insufficient. In this case, we recommend attaching a capacitor (about 0.1  $\mu\text{F}$ ) to an analog input pin.



9.1.5.3 Glossary

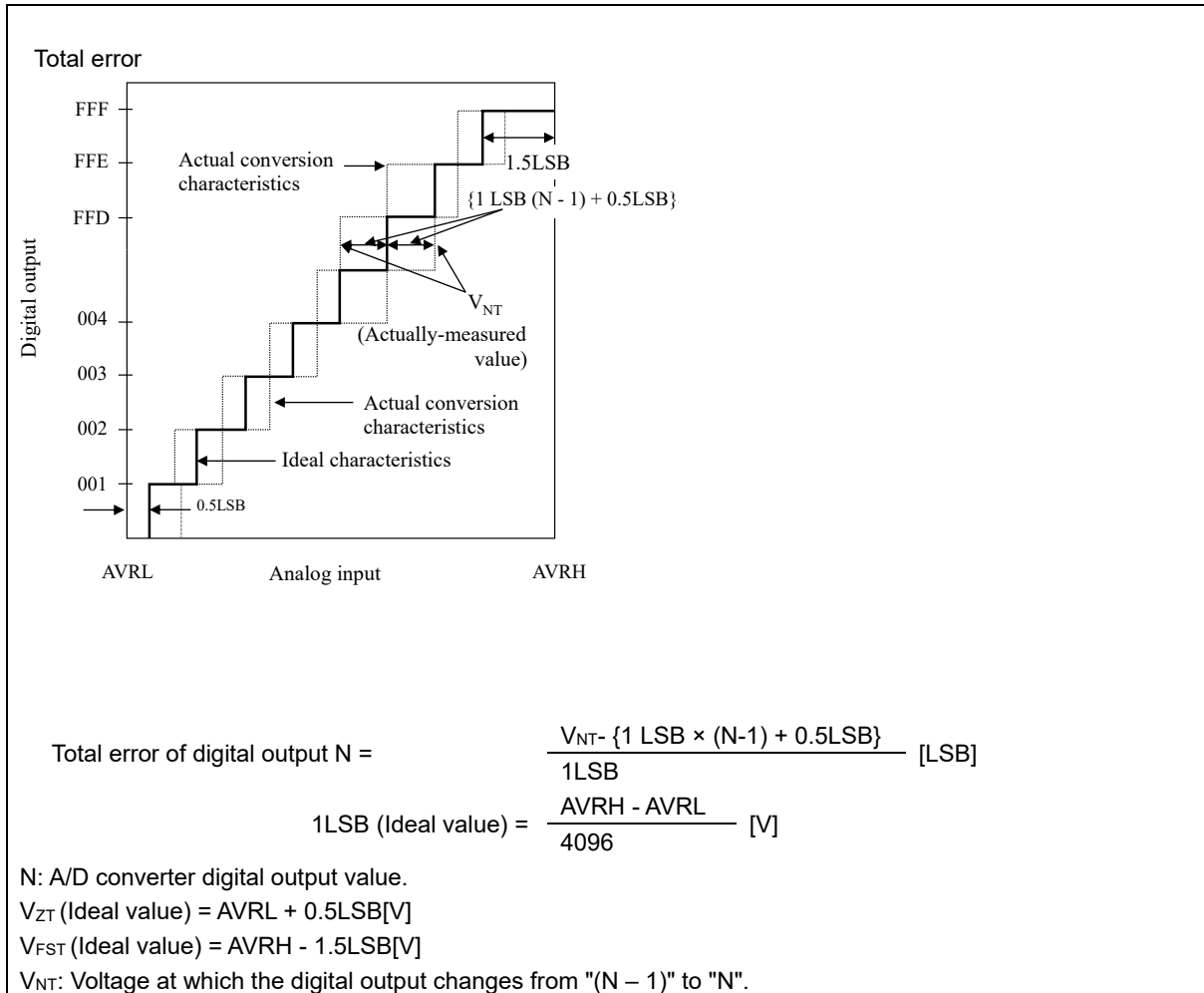
Resolution: Analog change that can be identified by an A/D converter

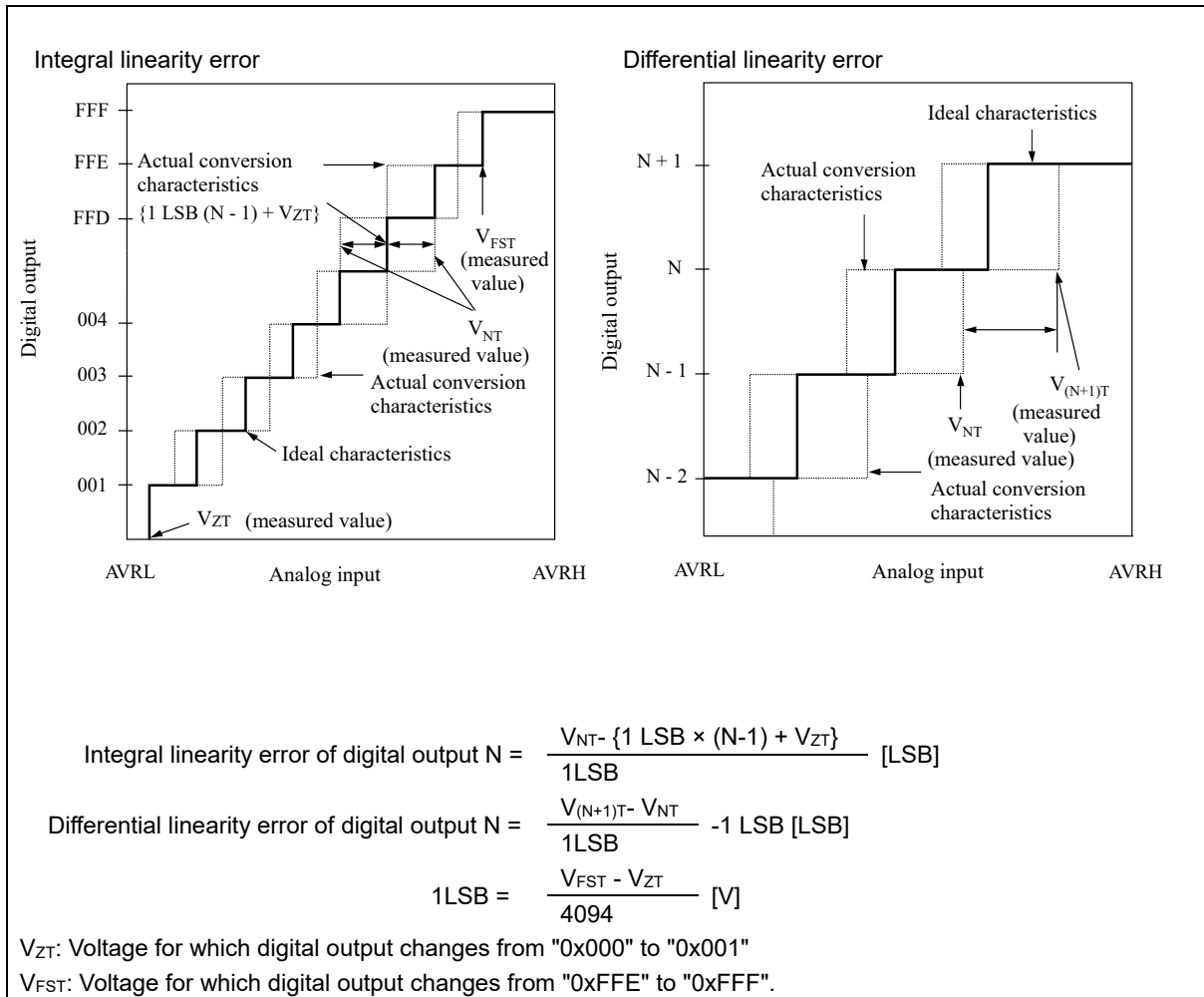
Integral linearity error: Deviation of the straight line connecting the zero transition point ("0000 0000 0000" <--> "0000 0000 0001") and full-scale transition point ("1111 1111 1110" <--> "1111 1111 1111") from actual conversion characteristics

includes zero transition error, full-scale transition error, and non linearity error.

Differential linearity error: Deviation from the ideal value of the input voltage required for changing the output code by 1 LSB

Total error: Difference between the actual value and the theoretical value. The total error







## 9.1.6 Audio DAC

### 9.1.6.1 Electrical Characteristics

(T<sub>A</sub>: Recommended operating conditions, AV<sub>CC3\_DAC</sub> = 3.3 V ± 0.3 V, V<sub>CC12</sub> = 1.15 V ± 0.06 V, V<sub>SS</sub> = AV<sub>SS</sub> = 0.0 V)

Parameter	Symbol	Pin Name	Conditions *1	Value			Unit	Remarks	
				Min	Typ	Max			
system clock frequency	F <sub>CLKDA0</sub>	-	-	2.048	-	18.432	MHz	-	
sampling clock	fs	-	-	8	-	48	kHz	-	
Analog output load resistance *2	R <sub>L</sub>	DAC_L DAC_R	-	20	-	-	kΩ	-	
Analog output load capacitance *2	C <sub>L</sub>	DAC_L DAC_R	-	-	-	100	pF	-	
capacitance	-	C <sub>L</sub> C <sub>R</sub>	-	1.1	2.2	10	μF	-	
Analog output single-end output range (±full scale)	-	DAC_L DAC_R	R <sub>L</sub> = 20 kΩ C <sub>L</sub> = 100 pF	-	0.673 AV <sub>CC3_DAC</sub>	-	V <sub>P-P</sub>	-	
Analog output voltage (zero)	-	-	-	-	0.5 AV <sub>CC3_DAC</sub>	-	V	-	
THD+N *3	-	-	signal frequency: 1 kHz LPF (fc: 20 kHz)	-	-82	-72	dB	-	
SNR *3	-	-	signal frequency: 1 kHz LPF (fc: 20 kHz)— — A-weighting filter	85	89	-	dB	-	
Dynamic range *3	-	-	20 kHz to 64 fs	83	86	-	dB	-	
Out-of-Band Energy	-	-	-	-	-	-33	dB	-	
Channel Separation	-	-	-	-	80	-	dB	-	
Output impedance	-	-	-	150	200	250	Ω	-	
PSRR	-	-	digital input: zero	noise 50 Hz	-	-35	-	dB	-
				noise 1 kHz	-	-50	-	dB	-
				noise 20 kHz	-	-40	-	dB	-
			digital input: full scale sine	-	-13	-	dB	-	
Supply current normal operation	-	AV <sub>CC3_DAC</sub>	-	-	2.2	3.2	mA	-	
Supply current power-down	-	AV <sub>CC3_DAC</sub>	-	-	-	100	μA	-	
Startup Time *4	-	-	DAE↑	-	650 *6	-	ms	-	

\*1: All parameters specified fs = 44.1 kHz, system clock 256 fs and 16-bit data, R<sub>L</sub>-20 kΩ, C<sub>L</sub> = 100 pF, unless otherwise noted.

\*2: Refer to notes \*5

\*3: These values do not include the noise caused by the analog power supply. (Refer to \*7. Use examples)

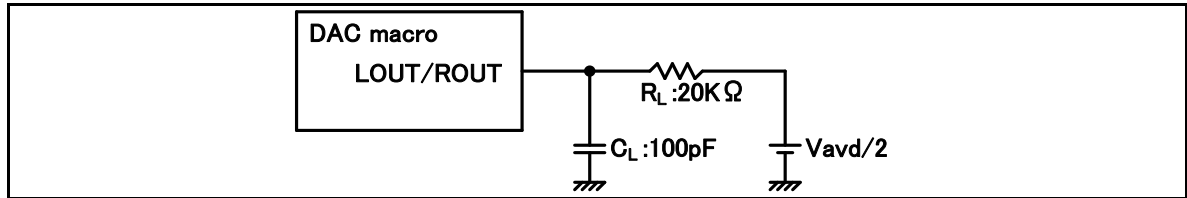
\*4: 2.2 μF is connected to C<sub>L</sub>, C<sub>R</sub>.

\*5: Load connection

R<sub>L</sub> is connected to AV<sub>CC3\_DAC</sub> /2 (Figure 9.1).

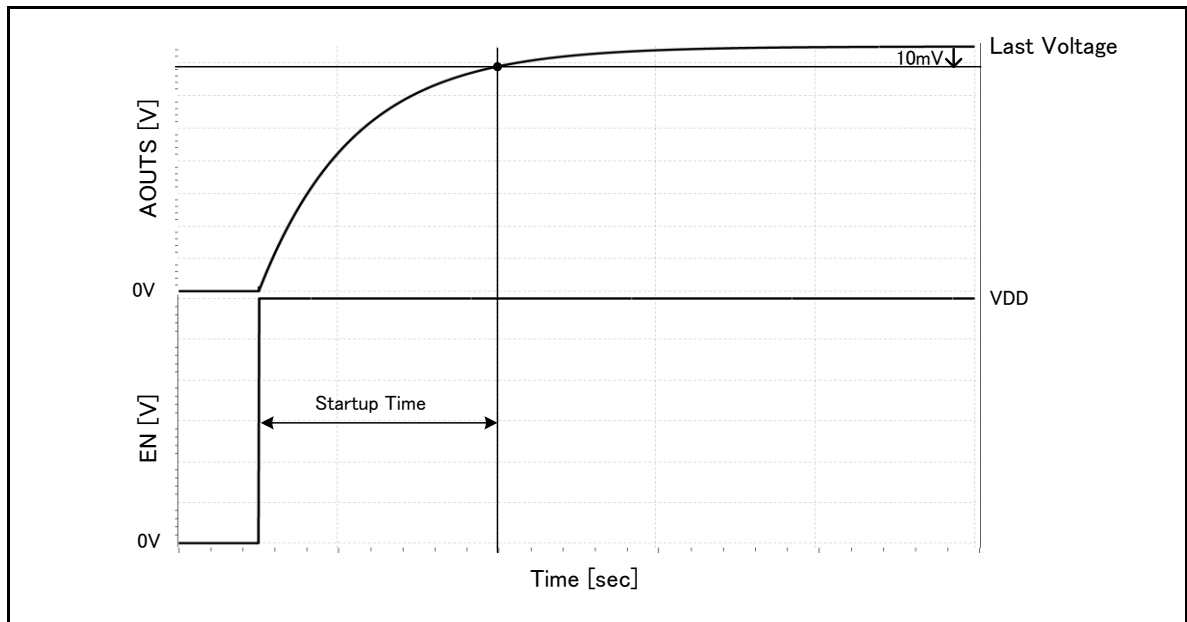
If R<sub>L</sub> is connected to ground, the coupling capacitance must be inserted as shown in (Figure 9.3)

Figure 9-1: Connection between R<sub>L</sub> and AVCC\_DAC/2 (Example)



\*6: Start up time

Figure 9-2: Startup Time



\*Start up time can be calculated as follows.

1. Start up time (TYP) = 650[ms] (\*4)

2. CCOM = 10 μF × (1 ± α/100)

CCOM is a capacitor connected to Terminal C\_L/C\_R including capacitance variance.

α = Capacitance variance[%]

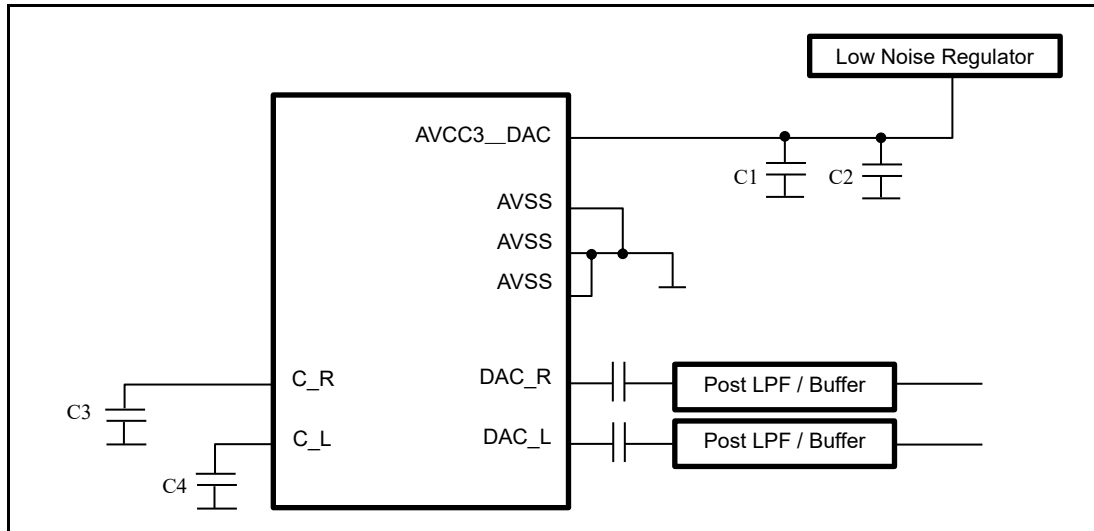
3. Start up time = Start up time (TYP) × (1±α) [ms]

For example, CCOM = 2.42 μF then α = (2.42 μF - 2.2 μF)/2.2 μF = 10[%]

So, Start up time = 650 ms × (1+10/100) = 715[ms]

\*7 Use examples

Figure 9-3: Coupling Capacitance (Example)



**Notes:**

- C1: more than 10  $\mu\text{F}$  low ESR capacitors
- C2: 0.1  $\mu\text{F}$  ceramic capacitors
- C3,C4: 2.2  $\mu\text{F}$  low ESR capacitors
- Impedance of each power line must be as low as possible.

**Notes:**

- When DAC is not used in your system, the related pins should be
- AVCC3\_DAC = GND and AVSS = GND
- C\_L = OPEN and C\_R = OPEN
- DAC\_L = OPEN and DAC\_R = OPEN

## 9.1.7 FLASH Memory

### 9.1.7.1 Electrical Characteristics

Parameter	Rating			Unit	Remarks
	Min	Typ	Max		
Sector erase time	-	120	180	ms	Large sector <sup>*1</sup> Internal preprogramming time included
	-	120	180	ms	8 kB sector <sup>*1</sup> Internal preprogramming time included
	-	120	180	ms	4 kB sector <sup>*2</sup> Internal preprogramming time included
16-bit write time (Program)	-	30	60	µs	System-level overhead time excluded <sup>*1</sup>
32-bit write time (Program)	-	30	60	µs	System-level overhead time excluded <sup>*1</sup>
64-bit write time (Program)	-	30	60	µs	System-level overhead time excluded <sup>*1</sup>
256-bit write time (Program)	-	40	70	µs	System-level overhead time excluded <sup>*1</sup>
Page mode write time (Program)	-	320	600	µs	System-level overhead time excluded <sup>*1</sup>
32-bit write time (Work)	-	30	60	µs	System-level overhead time excluded <sup>*2</sup>
Erase count / Data retention time (Program)	1,000/20 years	-	-	-	Temperature at write/erase time Average temperature T <sub>A</sub> = +85 degrees Celsius
Erase count / Data retention time (Work)	1,000/20 years 10,000/10 years 100,000/5 years	-	-	-	Temperature at write/erase time Average temperature T <sub>A</sub> = +85 degrees Celsius

\*1: Guaranteed value for up to 1,000 erases

\*2: Guaranteed value for up to 100,000 erases

#### 9.1.7.2 Notes

While the Flash memory is written or erased, shutdown of the external power (Vcc5) is prohibited.

In the application system where Vcc5 might be shut down while writing or erasing, be sure to turn the power off by using an external voltage detection function.

To put it concretely, after the external power supply voltage falls below the detection voltage (V<sub>DL</sub>), hold Vcc5 at 2.7 V or more within the duration calculated by the following expression:

$$T_d^{*1} [\mu s] + ( 1 / F_{CRF}^{*2} [MHz] ) \times 1029 + 25 [\mu s]$$

\*1: See "9.1.4.11 Low Voltage Detection (External Voltage)"

\*2: See "9.1.4.1 Source Clock Timing"

## 10. Acronyms

Acronym	Description
A/D converter	Analog digital converter
ADC	Analog digital converter
AHB	Advanced high performance bus
AMBATM	Advanced microcontroller bus architecture
APB	Advanced peripheral bus
ATCM	TCM-A port
AXI	Advanced extensible interface
B0TCM	TCM B0 port
B1TCM	TCM B1 port
BBU	Bit banding unit
BDR	Boot description record
BTL	Bridge-tied load
CAN	Control are network
CD	Clock domain
CPU	Central processing unit
CR	CR Oscillator
CRC	Cyclic redundancy check
CSV	Clock supervisor
DAC	Digital analog converter
DAP	Debug access port
DED	Dual error detection
DMA	Direct memory access
DMAC	DMA controller
EAM	Exclusive access memory
ECC	Error correction code
ETM	Embedded trace macro
EXT-IRC	External interrupt controller
FIQ	Fast interrupt request
FPU	Floating point unit
FRT	Free run timer
GPIO	General purpose I/O
HPM	High performance matrix
HW-WDT	Hardware watchdog timer
I/O	Input or output
I2S	Inter-IC sound
ICU	Input capture unit
IPCU	Inter-processor communication unit
IRC	Interrupt controller
IRQ	Interrupt request
ISR	Interrupt service routine
JTAG	Joint test action group

Acronym	Description
LLPP	Low latency peripheral port
LVD	Low voltage detector
MCU	Microcontroller unit
MFS	Multi-function serial interface
NF	Noise filter
NMI	Non maskable interrupt
OCU	Output compare unit
OSC	Oscillator
PCM	Pulse coded module
PLL	Phase locked loop
PONR	Power on reset
PPC	Port pin configuration
PSS	Power saving state
PWM	Pulse width modulation
RAM	Random access memory
RIC	Resource input configuration
ROM	Read only memory
RTC	Real time clock
RVD	Low voltage detection and reset for RAM retention
SCT	Source clock timer
SEC	Single error correction
SECEDED	Single error correction and dual error detection
SHE	Secure Hardware Extension
SMC	Stepper motor controller
SMIX	Sound mixer
SRAM	Static RAM
SWFG	Sound waveform generator
SW-WDT	Software watchdog timer
SYSC	System controller
TCFLASH	FLASH connected to TCM
TCM	Tightly coupled memory
TCRAM	RAM connected to TCM
TPU	Timing protection unit
UDC	Up-down counter
VIC	Vectored interrupt controller
VRAM	Video RAM
WDR	Watchdog description record
WDT	Watchdog timer
WFG	Waveform generator
WorkFLASH	Work FLASH memory

**11. Ordering Information**

Part Number	Package
S6J331EKSESE20000	208-pin plastic TEQFP (LEW208)
S6J332CKSDSE20000	208-pin plastic TEQFP (LEW208)
S6J334CKSESE20000	208-pin plastic TEQFP (LEW208)
S6J331EJSESE20000	176-pin plastic TEQFP (LEV176)
S6J332EJBDSE20000	176-pin plastic TEQFP (LEV176)
S6J332EJTDSE20000	176-pin plastic TEQFP (LEV176)
S6J332EJBESE20000	176-pin plastic TEQFP (LEV176)
S6J332EJTESE20000	176-pin plastic TEQFP (LEV176)
S6J332DJEESE20000	176-pin plastic TEQFP (LEV176)
S6J334BJDDSE20000	176-pin plastic TEQFP (LEV176)
S6J334EJBESE20000	176-pin plastic TEQFP (LEV176)
S6J334EJTESE20000	176-pin plastic TEQFP (LEV176)
S6J334EJEESE20000	176-pin plastic TEQFP (LEV176)
S6J334DJTESE20000	176-pin plastic TEQFP (LEV176)
S6J334DJEESE20000	176-pin plastic TEQFP (LEV176)
S6J334CJBESE20000	176-pin plastic TEQFP (LEV176)
S6J334CJEESE20000	176-pin plastic TEQFP (LEV176)
S6J334BJDESE20000	176-pin plastic TEQFP (LEV176)
S6J334EJTCSE2000A	176-pin plastic TEQFP (LEV176)
S6J334EJEDSE2000A	176-pin plastic TEQFP (LEV176)
S6J332EHBSESE20000	144-pin plastic TEQFP (LEX144, LEK144)
S6J334EHEESE20000	144-pin plastic TEQFP (LEX144, LEK144)
S6J334DHEESE20000	144-pin plastic TEQFP (LEX144, LEK144)
S6J334DHFSESE20000	144-pin plastic TEQFP (LEX144, LEK144)
S6J334CHEESE20000	144-pin plastic TEQFP (LEX144, LEK144)
S6J334CHFSESE20000	144-pin plastic TEQFP (LEX144, LEK144)

## 12. Errata

This section describes the errata for the S6J3310/3320/3330/3340 Series. Details include errata trigger conditions, scope of impact, available workarounds, and silicon revision applicability. Contact your local Cypress Sales Representative if you have questions.

### Part Numbers Affected

Part Number
S6J331xxxx
S6J332xxxx
S6J333xxxx
S6J334xxxx

### S6J331/2/3/4 Qualification Status

Product Status: Production

### Errata Summary

The following table defines the errata applicability to available S6J3310/3320/3330/3340 Series devices.

Items	Part Number	Fix Status
MCAN wrong message transmission	S6J331xxxx S6J332xxxx S6J333xxxx S6J334xxxx	Not be planned.

#### 1. MCAN wrong message transmission

##### ■ Problem Definition

There is a possibility a message with an ID (arbitration field) and a format and DLC (control field) is transmitted which was not configured by the application. The message itself is syntactically correct and can be received by other nodes.

The occurrence of the limitation requires a certain relationship in time between a transmission request for sending a message and the coincidence of noise in the 3rd bit of intermission field which is treated as the start of new message transmission (SoF).

##### ■ Trigger Condition

Under the following conditions a message with wrong ID, format and DLC is transmitted:

- M\_CAN is in state "Receiver" (PSR.ACT = "10"), no pending transmission.
- A new transmission is requested after sample point of 2nd bit of intermission but before the 3rd bit of Intermission is reached.
- The CAN bus is sampled dominant at the third bit of Intermission which is treated as SoF (see ISO11898-1:2015 Section 10.4.2.2).

##### ■ Scope of Impact

Under the conditions listed above it may happen, that:

- The shift register is not loaded with ID, format, and DLC of the requested message.
- The M\_CAN will start arbitration with wrong ID, format, and DLC.

- In case the ID won arbitration, a CAN message with valid CRC is transmitted.
- In case this message is acknowledged, the ID stored in the Tx Event FIFO is the ID of the requested Tx message and not the ID of the message transmitted on the CAN bus
- Neither an error is detected by the transmitting node nor at the receiving node.

#### ■ Workaround

##### Workaround 1:

This workaround avoids submitting a transmission request in the critical time window of about one bit time before the sample point of the 3<sup>rd</sup> bit of intermission field when on other pending transmission request exists:

- Request a new transmission if another transmission is already pending or when the M\_CAN / M\_TTCAN is not in state "Receiver" (when PSR.ACT ≠ "10").
- If no pending transmission request exists, the application software needs to evaluate the Rx Interrupt flags IR.DRX, IR.RF0N, IR.RF1N which are set at the last bit of EoF when a received and accepted message gets valid.
- A new transmission may be requested by writing to TXBAR once the Rx interrupt occurred and the application waited another 3 bit times before submitting its Tx request. Note the Rx interrupt is generated at the last bit of EoF which is followed by three bits of Intermission.
- The application has to take care that the transmission request for the CAN Protocol Controller is activated before the critical window of the following reception is reached.

A supplemental action can be applied in order to detect messages which contain wrong ID and control filed information:

- A checksum covering arbitration and control fields can be added to the data field of the message to be transmitted, to detect frames transmitted with wrong arbitration and control fields.

##### Workaround 2:

This workaround ensures that always at least one pending Tx request exists. If that is the case, the application may launch its Tx requests at any time without suffering from the limitation.

- Define a low priority message with DLC = 0 that can be sent without harm. E.g. loses arbitration against all other application messages, does not pass any acceptance filter of nodes in the same network. DLC = 0 shall reduce latency for other application messages.
- Configure sufficient Tx buffers – at least two - for this message type thus that there is always another one waiting to be sent. E.g. an application that cannot react quickly enough with the time a single message of this type is sent, more than 2 Tx buffer may become necessary.
- The application uses the standard interfaces of the CAN / CAN FD stack to feed these messages.
- Whenever Tx confirmation is indicated for the second but last message of this type with pending Tx request, the application needs to submit at least one new Tx request. Note Tx confirmation is a standard feature in the AUTOSAR SW architecture.
- Before initially leaving INIT state of the M\_CAN IP by clearing CCCR.INIT bit, make sure to activate a Tx request after having cleared CCCR.CCE. This will ensure that the conditions for the occurrence of the limitation when synchronizing to the CAN bus the first time after RESET are prevented.

#### ■ Fix Status

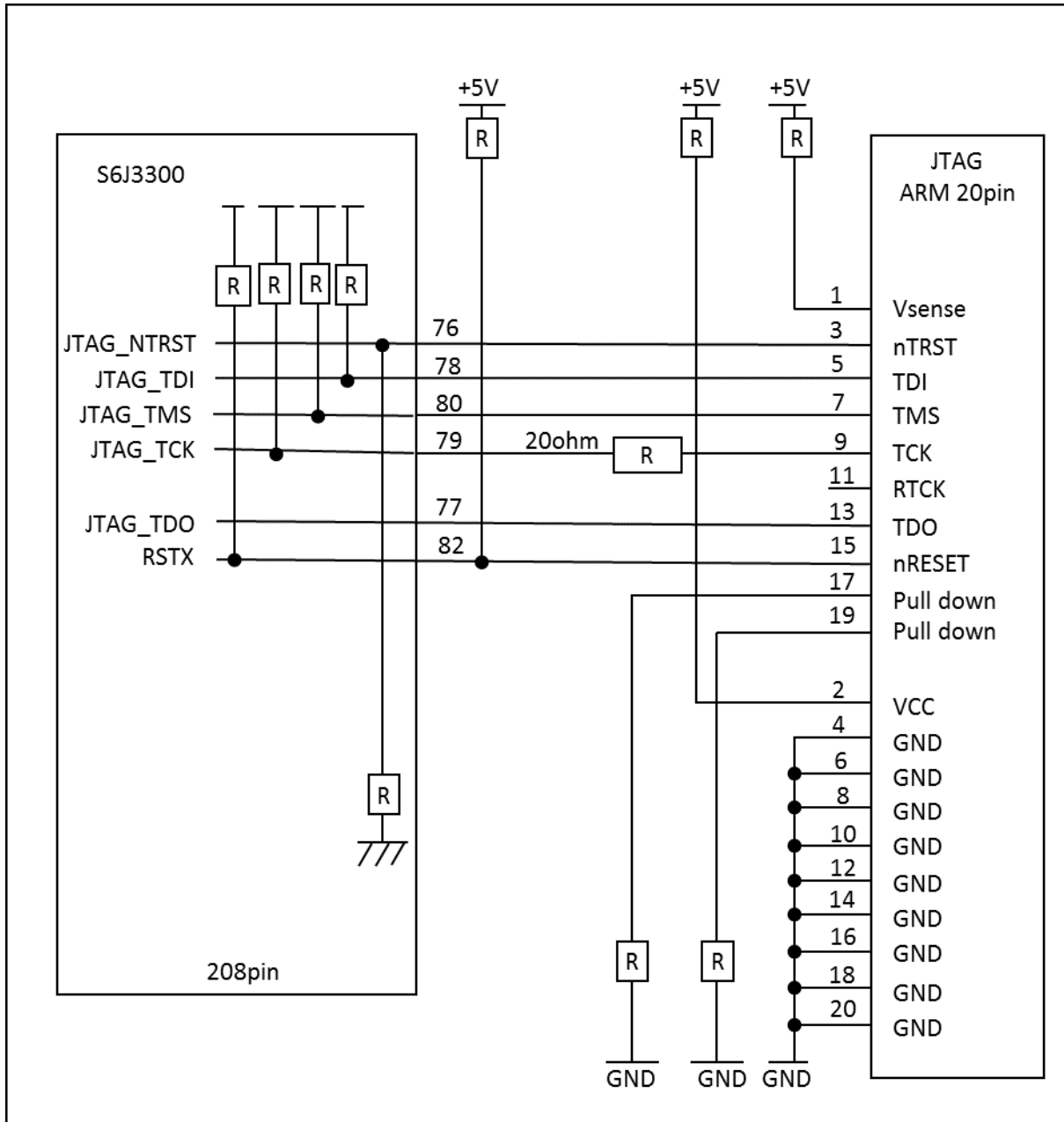
Not be planned.



### 13. Appendix

#### 13.1 Application 1: JTAG Tool Connection

This is an application example of JTAG tool connection. See the relevant application note 002-03898 in detail.



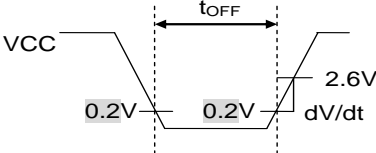
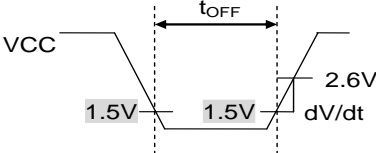
14. Major Changes

Page	Section	Change Results																								
Rev. *A																										
7	2.Function List 2.2Optional function	<p>Revised CHIP-ID and Revision as below: Error)</p> <table border="0"> <tr> <td>Function Digit</td> <td>Revision</td> <td>Chip ID</td> </tr> <tr> <td>S,U,T,V</td> <td><b>B</b></td> <td>0x10120000</td> </tr> <tr> <td>A,C,E,G</td> <td><b>B</b></td> <td>0x1012A000</td> </tr> <tr> <td>B,D,F,H</td> <td><b>B</b></td> <td>0x10122000</td> </tr> </table> <p>Correct)</p> <table border="0"> <tr> <td>Function Digit</td> <td>Revision</td> <td>Chip ID</td> </tr> <tr> <td>S,U,T,V</td> <td><b>C</b></td> <td>0x10122100</td> </tr> <tr> <td>A,C,E,G</td> <td><b>C</b></td> <td>0x10128100</td> </tr> <tr> <td>B,D,F,H</td> <td><b>C</b></td> <td>0x10120100</td> </tr> </table>	Function Digit	Revision	Chip ID	S,U,T,V	<b>B</b>	0x10120000	A,C,E,G	<b>B</b>	0x1012A000	B,D,F,H	<b>B</b>	0x10122000	Function Digit	Revision	Chip ID	S,U,T,V	<b>C</b>	0x10122100	A,C,E,G	<b>C</b>	0x10128100	B,D,F,H	<b>C</b>	0x10120100
Function Digit	Revision	Chip ID																								
S,U,T,V	<b>B</b>	0x10120000																								
A,C,E,G	<b>B</b>	0x1012A000																								
B,D,F,H	<b>B</b>	0x10122000																								
Function Digit	Revision	Chip ID																								
S,U,T,V	<b>C</b>	0x10122100																								
A,C,E,G	<b>C</b>	0x10128100																								
B,D,F,H	<b>C</b>	0x10120100																								
8	2.Function List 2.2Optional function	<p>Revised as below: Error)</p> <p>TEQFP144 Analog input port(12bit-ADC) AN4~7, AN10~11, AN14~15, AN19~20, AN22~23, AN25~30, AN33~38, AN48</p> <p>Correct)</p> <p>TEQFP144 Analog input port(12bit-ADC) AN4~7, AN10~11, AN14~15, AN25~26, AN28~30</p>																								
10	3.Product Description 3.2Product description	<p>Revised 4MHz to 16MHz as below: Error)</p> <p>-A wide range of 3.6 - 4MHz is available for main oscillator</p> <p>Correct)</p> <p>-A wide range of 3.6 - 16MHz is available for main oscillator</p>																								
13	3. Product Description 3.2Product description	<p>Added Note of a function as below: Multi-Functional Serial (MFS)</p> <p>Correct)</p> <p>CTS/RTS is not mounted (hardware flow control is not supported for this series.)</p>																								
14	3. Product Description 3.2Product description	<p>Revised Graphics Subsystem clock frequency as below: Error)</p> <p>200 MHz maximum clock frequency Video modes up to 50 MHz pixel clock</p> <p>Correct)</p> <p>80 MHz maximum clock frequency Video modes up to 25 MHz pixel clock</p>																								

Page	Section	Change Results
81	7. Port Configuration 7.1 Resource Input Configuration Module	<p>Revised as below: Error) RIC_RESIN235(0x01D6) OCU1_CK0, OCU1_CK1, OCU1_DOWNB0, OCU1_DOWNB1, OCU1_FCMD0, OCU1_FCMD1, OCU1_MTSF0, OCU1_MTSF1, OCU1_T0[31:0], OCU1_T1[31:0] RIC_RESIN236(0x01D8) OCU1_ZTSF0, OCU1_ZTSF1, OCU1_MOD0</p> <p>Correct) RIC_RESIN235(0x01D6) OCU1_CK0, OCU1_CK1, OCU1_DOWNB0, OCU1_DOWNB1, OCU1_FCMD0, OCU1_FCMD1, OCU1_MTSF0, OCU1_MTSF1, OCU1_T0[31:0], OCU1_T1[31:0], OCU1_ZTSF0, OCU1_ZTSF1 RIC_RESIN236(0x01D8) OCU1_MOD0</p>
155	8.Precautions and Handling Devices 8.1.1Precautions for Product Design	<p>Revised as below: Error) (1) Preventing Over-Voltage and Over-Current Conditions Exposure to voltage or current levels in excess of maximum ratings at any pin is likely to cause deterioration within the device, and in extreme cases leads to permanent damage of the device. Try to prevent such overvoltage or over-current conditions at the design stage.</p> <p>Correct) (1) Preventing Over-Voltage and Over-Current Conditions Exposure to voltage or current levels in excess of maximum ratings at any pin is likely to cause deterioration within the device and in extreme cases leads to permanent damage of the device. Try to prevent such overvoltage or over-current conditions at the design stage.</p>
156	8.Precautions and Handling Devices 8.1.2Precautions for Package Mounting	<p>Revised as below: Error) Surface Mount Type</p> <p>Correct) <b>Surface Mount Type</b></p>
159	9.Electric Characteristics 9.1.1 Absolute Maximum Rating	<p>Deleted Remarks comment as below: Error) Supply voltage Operation assurance range, DV<sub>CC</sub>, Remarks "DV<sub>CC</sub>≤V<sub>CC5</sub>"</p> <p>Correct) Power supply voltage, DV<sub>CC</sub>, Remarks ""</p>
159	8.2Handling Devices	<p>Added Note of a function as below: Method to Switch off VCC12 during Power-off Sequence During power-off sequence, it is necessary to switch off VCC12 by driving PSC1 pin low by entering PSS mode (power domain 2 off). If VCC12 needs to be switched off by other means, RSTX needs to be asserted before switching off VCC12 to inactivate the operation of VCC12 supplied domain below the operation assurance range.</p>

Page	Section	Change Results
159 160	9.Electric Characteristics 9.1.1 Absolute Maximum Rating	Added Note of a comment as below: Maximum clamp current, Total maximum clamp current  Correct) *13 VI or VO should never exceed the specified ratings. However, if the maximum current to/from an input is limited by a suitable external resistor, the ICLAMP rating supersedes the VI rating.
161	9.Electric Characteristics 9.1.1 Absolute Maximum Rating	Revised Warning of a comment as below: Error) Note: - Application of stress (e.g., voltage, current, temperature) exceeding the absolute maximum rating may cause damage to the semiconductor device. Therefore, make sure that nothing exceeds the rating.  Correct) WARNING: - Semiconductor devices may be permanently damaged by application of stress (including, without limitation, voltage, current or temperature) in excess of absolute maximum ratings. Do not exceed any of these ratings.
162	9.Electric Characteristics 9.1.2Recomme nded operating condition	Revised Rating Min Spec as below: Error) Power supply voltage, V <sub>CC5</sub> , Rating, Min, 2.6 Power supply voltage, V <sub>CC3</sub> , Rating, Min, 2.6  Correct) Power supply voltage, V <sub>CC5</sub> , Rating, Min, 2.7 Power supply voltage, V <sub>CC3</sub> , Rating, Min, 2.7
162 163	9.Electric Characteristics 9.1.2Recomme nded operating condition	Added comment as below: Supply voltage Operation assurance range,VCC12, VCC12  Correct) *5:When the voltage of Vcc12 is in the out of range against supply voltage operation assurance, the operation of circuit which Vcc12 used as the power source becomes unstable status. In that case, the value of each registers including RESCAUSEUR Register cannot be guaranteed, so these flags should don't care by software processing
162 163 215 236	9.Electric Characteristics 9.1.2Recomme nded operating condition 9.1.4.11Low Voltage Detection (External Voltage) 9.1.5 A/D converter	Revised device revision from B to C as below: Error) S6J33xxxSB , S6J33xxxUB, S6J33xxxTB, S6J33xxxVB, S6J33xxxBB, S6J33xxxDB, S6J33xxxFB, S6J33xxxHB, S6J33xxxAB, S6J33xxxCB, S6J33xxxEB, S6J33xxxGB  Correct) S6J33xxxSC, S6J33xxxUC, S6J33xxxTC, S6J33xxxVC, S6J33xxxBC, S6J33xxxDC, S6J33xxxFC, S6J33xxxHC, S6J33xxxAC, S6J33xxxCC, S6J33xxxEC, S6J33xxxGC

Page	Section	Change Results																																																																														
167	9.Electric Characteristics 9.1.3 DC characteristics	Deleted VOH25 Spec as below: Error) VOH25 Correct) Non																																																																														
169	9.Electric Characteristics 9.1.3 DC characteristics	Deleted VOL25 Spec as below: Error) VOL25 Correct) Non																																																																														
175	9.1 Electrical Characteristics 9.1.4 AC characteristics 9.1.4.3 Internal clock timing (S6J3310)	Revised as below: Error) Internal clock frequency, $F_{CLK\_HAPP1B0}$ , Value, Max *1, 60MHz Correct) Internal clock frequency, $F_{CLK\_HAPP1B0}$ , Value, Max *1, 80MHz																																																																														
180	9.Electric Characteristics 9.1.4.5 Power-on Conditions	Revised as below: Error) <table border="1"> <thead> <tr> <th rowspan="2">Parameter</th> <th rowspan="2">Symbol</th> <th rowspan="2">Pin Name</th> <th rowspan="2">Conditions</th> <th colspan="3">Value</th> <th rowspan="2">Unit</th> <th rowspan="2">Remarks</th> </tr> <tr> <th>Min</th> <th>Typ</th> <th>Max</th> </tr> </thead> <tbody> <tr> <td>Power off time</td> <td>-</td> <td>VCC5</td> <td>-</td> <td>50</td> <td>-</td> <td>-</td> <td>ms</td> <td>*2</td> </tr> <tr> <td>Power ramp rate</td> <td>dV/dt</td> <td>VCC5</td> <td>VCC5: 0.2V to 2.6V</td> <td>-</td> <td>-</td> <td>1</td> <td>V/μs</td> <td>*3</td> </tr> <tr> <td>Undetected power ramp rate</td> <td> dV/dt </td> <td>VCC5</td> <td>VCC5: Between 2.4V and 4.5V</td> <td>-</td> <td>-</td> <td>50</td> <td>mV/μs</td> <td>*4</td> </tr> </tbody> </table> Correct) <table border="1"> <thead> <tr> <th rowspan="2">Parameter</th> <th rowspan="2">Symbol</th> <th rowspan="2">Pin Name</th> <th rowspan="2">Conditions</th> <th colspan="3">Value</th> <th rowspan="2">Unit</th> <th rowspan="2">Remarks</th> </tr> <tr> <th>Min</th> <th>Typ</th> <th>Max</th> </tr> </thead> <tbody> <tr> <td>Power off time</td> <td>-</td> <td>VCC5</td> <td>-</td> <td>100</td> <td>-</td> <td>-</td> <td>μs</td> <td>*2</td> </tr> <tr> <td>Power ramp rate</td> <td>dV/dt</td> <td>VCC5</td> <td>VCC5: 1.5V to 2.6V</td> <td>-</td> <td>-</td> <td>1</td> <td>V/μs</td> <td>*3</td> </tr> <tr> <td>Maximum ramp rate guaranteed to not generate power-on reset</td> <td> dV/dt </td> <td>VCC5</td> <td>VCC5: Between 2.4V and 4.5V</td> <td>-</td> <td>-</td> <td>50</td> <td>mV/μs</td> <td>*4</td> </tr> </tbody> </table>	Parameter	Symbol	Pin Name	Conditions	Value			Unit	Remarks	Min	Typ	Max	Power off time	-	VCC5	-	50	-	-	ms	*2	Power ramp rate	dV/dt	VCC5	VCC5: 0.2V to 2.6V	-	-	1	V/μs	*3	Undetected power ramp rate	dV/dt	VCC5	VCC5: Between 2.4V and 4.5V	-	-	50	mV/μs	*4	Parameter	Symbol	Pin Name	Conditions	Value			Unit	Remarks	Min	Typ	Max	Power off time	-	VCC5	-	100	-	-	μs	*2	Power ramp rate	dV/dt	VCC5	VCC5: 1.5V to 2.6V	-	-	1	V/μs	*3	Maximum ramp rate guaranteed to not generate power-on reset	dV/dt	VCC5	VCC5: Between 2.4V and 4.5V	-	-	50	mV/μs	*4
Parameter	Symbol	Pin Name					Conditions	Value				Unit	Remarks																																																																			
			Min	Typ	Max																																																																											
Power off time	-	VCC5	-	50	-	-	ms	*2																																																																								
Power ramp rate	dV/dt	VCC5	VCC5: 0.2V to 2.6V	-	-	1	V/μs	*3																																																																								
Undetected power ramp rate	dV/dt	VCC5	VCC5: Between 2.4V and 4.5V	-	-	50	mV/μs	*4																																																																								
Parameter	Symbol	Pin Name	Conditions	Value			Unit	Remarks																																																																								
				Min	Typ	Max																																																																										
Power off time	-	VCC5	-	100	-	-	μs	*2																																																																								
Power ramp rate	dV/dt	VCC5	VCC5: 1.5V to 2.6V	-	-	1	V/μs	*3																																																																								
Maximum ramp rate guaranteed to not generate power-on reset	dV/dt	VCC5	VCC5: Between 2.4V and 4.5V	-	-	50	mV/μs	*4																																																																								

Page	Section	Change Results
180	9.Electric Characteristics 9.1.4.5 Power-on Conditions	<p>Revised device revision as below:            Error)</p> <p>*1: This specification is at 1V/<math>\mu</math>s of power ramp rate.            *2: VCC5 must be held below 0.2V for a minimum period of t<sub>OFF</sub>.            *3: Power ramp rate must be 1V/<math>\mu</math>s or less from 0.2V to 2.6V.            Power-on can detect by satisfying power ramp rate when power off time is satisfied.            *4: This specification is specified the power supply fluctuation after power on detection. When VCC5 voltage is between 2.4V and 4.5V, the power supply fluctuation is below 50mV/<math>\mu</math>s, the detection of power-on is suppressed. The power-on does not detect in any power fluctuation between 4.5V and 5.5V.</p> <p><b>Notes:</b>            When using S6J3310/20/30/40, *2 and *3 must be satisfied. When neither *2 nor *3 can be satisfied, assert external reset (RSTX) at power up and any brownout event.</p> <div data-bbox="415 741 1463 1041" style="border: 1px solid black; padding: 5px;"> <p>• Power off time, Power ramp rate</p>  </div> <p>Correct)</p> <p>*1: This specification is at 1V/<math>\mu</math>s of power ramp rate.            *2: VCC5 must be held below 1.5V for a minimum period of t<sub>OFF</sub>.            *3: Power ramp rate must be 1V/<math>\mu</math>s or less from 1.5V to 2.6V.            Power-on can detect by satisfying power ramp rate when power off time is satisfied.            *4: This specification is specified the power supply fluctuation after power on detection. When VCC5 voltage is between 2.4V and 4.5V, the power supply fluctuation is below 50mV/<math>\mu</math>s, the detection of power-on is suppressed. The power-on does not detect in any power fluctuation between 4.5V and 5.5V.</p> <p><b>Notes:</b>            When using S6J3310/20/30/40, *2 and *3 must be satisfied. When neither *2 nor *3 can be satisfied, assert external reset (RSTX) at power up and any brownout event.</p> <div data-bbox="415 1444 1463 1759" style="border: 1px solid black; padding: 5px;"> <p>• Power off time, Power ramp rate</p>  </div>

Page	Section	Change Results																																													
185 186	9.Electric Characteristics 9.1.4.6Multi-Function Serial	Deleted Remarks comment as below: (2) Normal synchronous transfer (SCR:SPI=0) and mark level "L" of serial clock output (SMR:SCINV=1) Error) Master Mode(CL=20pF, IOL=-5mA, IOH=5mA) Master Mode(CL=20pF, IOL=-10mA, IOH=10mA) @20MHz, @16MHz, 12.5MHz  Correct) Non																																													
215	9.Electric Characteristics 9.1.4.11 Low Voltage Detection (External Voltage)	Revised Max of Low-voltage detection time as below: Low-voltage detection (external low-voltage detection) Error) <table border="1"> <tr> <td>Low-voltage detection time</td> <td>Td</td> <td>-</td> <td>-</td> <td>-</td> <td>-</td> <td>30</td> <td>μs</td> <td></td> </tr> </table> Correct) <table border="1"> <tr> <td>Low-voltage detection time</td> <td>Td</td> <td>-</td> <td>-</td> <td>-</td> <td>-</td> <td>40</td> <td>μs</td> <td></td> </tr> </table>	Low-voltage detection time	Td	-	-	-	-	30	μs		Low-voltage detection time	Td	-	-	-	-	40	μs																												
Low-voltage detection time	Td	-	-	-	-	30	μs																																								
Low-voltage detection time	Td	-	-	-	-	40	μs																																								
216	9.Electric Characteristics 9.1.4.11 Low Voltage Detection (External Voltage)	Revised as below: Low-voltage detection (1.15 V power supply low-voltage detection) Error) <table border="1"> <thead> <tr> <th rowspan="2">Parameter</th> <th rowspan="2">Symbol</th> <th rowspan="2">Pin Name</th> <th rowspan="2">Conditions</th> <th colspan="3">Value</th> <th rowspan="2">Unit</th> <th rowspan="2">Remarks</th> </tr> <tr> <th>Min</th> <th>Typ</th> <th>Max</th> </tr> </thead> <tbody> <tr> <td rowspan="2">Detection voltage (after trimming)</td> <td rowspan="2">VRDLAT</td> <td rowspan="2">VCC12</td> <td rowspan="2">*1</td> <td>0.784</td> <td>0.8125</td> <td>0.841</td> <td rowspan="2">V</td> <td rowspan="2">When power-supply voltage falls Typ±3.5%</td> </tr> <tr> <td>0.888</td> <td>0.95</td> <td>0.984</td> </tr> </tbody> </table> Correct) <table border="1"> <thead> <tr> <th rowspan="2">Parameter</th> <th rowspan="2">Symbol</th> <th rowspan="2">Pin Name</th> <th rowspan="2">Conditions</th> <th colspan="3">Value</th> <th rowspan="2">Unit</th> <th rowspan="2">Remarks</th> </tr> <tr> <th>Min</th> <th>Typ</th> <th>Max</th> </tr> </thead> <tbody> <tr> <td>Detection voltage (after trimming)</td> <td>VRDLAT</td> <td>VCC12</td> <td>*1</td> <td>0.7841</td> <td>0.8125</td> <td>0.8410</td> <td>V</td> <td>When power-supply voltage falls Typ±3.5%</td> </tr> </tbody> </table>	Parameter	Symbol	Pin Name	Conditions	Value			Unit	Remarks	Min	Typ	Max	Detection voltage (after trimming)	VRDLAT	VCC12	*1	0.784	0.8125	0.841	V	When power-supply voltage falls Typ±3.5%	0.888	0.95	0.984	Parameter	Symbol	Pin Name	Conditions	Value			Unit	Remarks	Min	Typ	Max	Detection voltage (after trimming)	VRDLAT	VCC12	*1	0.7841	0.8125	0.8410	V	When power-supply voltage falls Typ±3.5%
Parameter	Symbol	Pin Name					Conditions	Value				Unit	Remarks																																		
			Min	Typ	Max																																										
Detection voltage (after trimming)	VRDLAT	VCC12	*1	0.784	0.8125	0.841	V	When power-supply voltage falls Typ±3.5%																																							
				0.888	0.95	0.984																																									
Parameter	Symbol	Pin Name	Conditions	Value			Unit	Remarks																																							
				Min	Typ	Max																																									
Detection voltage (after trimming)	VRDLAT	VCC12	*1	0.7841	0.8125	0.8410	V	When power-supply voltage falls Typ±3.5%																																							
217	9.Electric Characteristics 9.1.4.12Low Voltage Detection (Internal Voltage)	Revised as below: Low-voltage detection (internal low-voltage detection for LVDL0) Error) <table border="1"> <thead> <tr> <th rowspan="2">Parameter</th> <th rowspan="2">Symbol</th> <th rowspan="2">Pin Name</th> <th rowspan="2">Conditions</th> <th colspan="3">Value</th> <th rowspan="2">Unit</th> <th rowspan="2">Remarks</th> </tr> <tr> <th>Min</th> <th>Typ</th> <th>Max</th> </tr> </thead> <tbody> <tr> <td>Hysteresis width</td> <td>VRHYS</td> <td>-</td> <td>-</td> <td>-</td> <td>100</td> <td>-</td> <td>mV</td> <td>When power-supply voltage rises</td> </tr> </tbody> </table> Correct) <table border="1"> <thead> <tr> <th rowspan="2">Parameter</th> <th rowspan="2">Symbol</th> <th rowspan="2">Pin Name</th> <th rowspan="2">Conditions</th> <th colspan="3">Value</th> <th rowspan="2">Unit</th> <th rowspan="2">Remarks</th> </tr> <tr> <th>Min</th> <th>Typ</th> <th>Max</th> </tr> </thead> <tbody> <tr> <td>Hysteresis width</td> <td>VRHYS</td> <td>-</td> <td>-</td> <td>-</td> <td>75</td> <td>-</td> <td>mV</td> <td>When power-supply voltage rises</td> </tr> </tbody> </table>	Parameter	Symbol	Pin Name	Conditions	Value			Unit	Remarks	Min	Typ	Max	Hysteresis width	VRHYS	-	-	-	100	-	mV	When power-supply voltage rises	Parameter	Symbol	Pin Name	Conditions	Value			Unit	Remarks	Min	Typ	Max	Hysteresis width	VRHYS	-	-	-	75	-	mV	When power-supply voltage rises			
Parameter	Symbol	Pin Name					Conditions	Value				Unit	Remarks																																		
			Min	Typ	Max																																										
Hysteresis width	VRHYS	-	-	-	100	-	mV	When power-supply voltage rises																																							
Parameter	Symbol	Pin Name	Conditions	Value			Unit	Remarks																																							
				Min	Typ	Max																																									
Hysteresis width	VRHYS	-	-	-	75	-	mV	When power-supply voltage rises																																							

Page	Section	Change Results																																																																																																
218	9.Electric Characteristics 9.1.4.12 Low Voltage Detection (Internal Voltage)	<p>Revised as below: Error)</p> <table border="1"> <thead> <tr> <th rowspan="2">Parameter</th> <th rowspan="2">Symbol</th> <th rowspan="2">Pin Name</th> <th rowspan="2">Conditions</th> <th colspan="3">Value</th> <th rowspan="2">Unit</th> <th rowspan="2">Remarks</th> </tr> <tr> <th>Min</th> <th>Typ</th> <th>Max</th> </tr> </thead> <tbody> <tr> <td>Supply voltage range</td> <td>V<sub>RDP5</sub></td> <td>-</td> <td>-</td> <td>1.05</td> <td>-</td> <td>1.21</td> <td>V</td> <td></td> </tr> <tr> <td>Detection voltage</td> <td>V<sub>RDL</sub></td> <td>-</td> <td>*1</td> <td>0.75</td> <td>0.85</td> <td>0.95</td> <td>V</td> <td>When power-supply voltage falls</td> </tr> <tr> <td>Hysteresis width</td> <td>V<sub>RHYS</sub></td> <td>-</td> <td>-</td> <td>-</td> <td>75</td> <td>-</td> <td>mV</td> <td>When power-supply voltage rises</td> </tr> <tr> <td>Low-voltage detection time</td> <td>TR<sub>d</sub></td> <td>-</td> <td>-</td> <td>-</td> <td>-</td> <td>30</td> <td>µs</td> <td></td> </tr> </tbody> </table> <p>*1: If the power fluctuation time is less than the low-voltage detection time (TR<sub>d</sub>) and has passed the detection voltage range, the detection may occur or be canceled after the supply voltage has passed the detection voltage range.</p> <p>Correct)</p> <table border="1"> <thead> <tr> <th rowspan="2">Parameter</th> <th rowspan="2">Symbol</th> <th rowspan="2">Pin Name</th> <th rowspan="2">Conditions</th> <th colspan="3">Value</th> <th rowspan="2">Unit</th> <th rowspan="2">Remarks</th> </tr> <tr> <th>Min</th> <th>Typ</th> <th>Max</th> </tr> </thead> <tbody> <tr> <td>Supply voltage range</td> <td>V<sub>RDP5</sub></td> <td>-</td> <td>-</td> <td>1.05</td> <td>-</td> <td>1.21</td> <td>V</td> <td></td> </tr> <tr> <td>Detection voltage</td> <td>V<sub>RDL</sub></td> <td>-</td> <td>*1</td> <td>0.75</td> <td>0.85</td> <td>0.95</td> <td>V</td> <td>When power-supply voltage falls *2</td> </tr> <tr> <td>Hysteresis width</td> <td>V<sub>RHYS</sub></td> <td>-</td> <td>-</td> <td>-</td> <td>75</td> <td>-</td> <td>mV</td> <td>When power-supply voltage rises</td> </tr> <tr> <td>Low-voltage detection time</td> <td>TR<sub>d</sub></td> <td>-</td> <td>-</td> <td>-</td> <td>-</td> <td>30</td> <td>µs</td> <td>*3</td> </tr> </tbody> </table> <p>*1: If the power fluctuation time is less than the low-voltage detection time (TR<sub>d</sub>) and has passed the detection voltage range, the detection may occur or be canceled after the supply voltage has passed the detection voltage range.</p> <p>*2: This LVD cannot be used to reliably generate a reset before voltage dips below minimum guaranteed MCU operation voltage, as these detection levels are below the minimum guaranteed MCU operation voltage.</p> <p>*3: After the brown-out event where the voltage level dips below the detection threshold for less than this time, the detection may occur or be canceled.</p>	Parameter	Symbol	Pin Name	Conditions	Value			Unit	Remarks	Min	Typ	Max	Supply voltage range	V <sub>RDP5</sub>	-	-	1.05	-	1.21	V		Detection voltage	V <sub>RDL</sub>	-	*1	0.75	0.85	0.95	V	When power-supply voltage falls	Hysteresis width	V <sub>RHYS</sub>	-	-	-	75	-	mV	When power-supply voltage rises	Low-voltage detection time	TR <sub>d</sub>	-	-	-	-	30	µs		Parameter	Symbol	Pin Name	Conditions	Value			Unit	Remarks	Min	Typ	Max	Supply voltage range	V <sub>RDP5</sub>	-	-	1.05	-	1.21	V		Detection voltage	V <sub>RDL</sub>	-	*1	0.75	0.85	0.95	V	When power-supply voltage falls *2	Hysteresis width	V <sub>RHYS</sub>	-	-	-	75	-	mV	When power-supply voltage rises	Low-voltage detection time	TR <sub>d</sub>	-	-	-	-	30	µs	*3
Parameter	Symbol	Pin Name					Conditions	Value				Unit	Remarks																																																																																					
			Min	Typ	Max																																																																																													
Supply voltage range	V <sub>RDP5</sub>	-	-	1.05	-	1.21	V																																																																																											
Detection voltage	V <sub>RDL</sub>	-	*1	0.75	0.85	0.95	V	When power-supply voltage falls																																																																																										
Hysteresis width	V <sub>RHYS</sub>	-	-	-	75	-	mV	When power-supply voltage rises																																																																																										
Low-voltage detection time	TR <sub>d</sub>	-	-	-	-	30	µs																																																																																											
Parameter	Symbol	Pin Name	Conditions	Value			Unit	Remarks																																																																																										
				Min	Typ	Max																																																																																												
Supply voltage range	V <sub>RDP5</sub>	-	-	1.05	-	1.21	V																																																																																											
Detection voltage	V <sub>RDL</sub>	-	*1	0.75	0.85	0.95	V	When power-supply voltage falls *2																																																																																										
Hysteresis width	V <sub>RHYS</sub>	-	-	-	75	-	mV	When power-supply voltage rises																																																																																										
Low-voltage detection time	TR <sub>d</sub>	-	-	-	-	30	µs	*3																																																																																										



Page	Section	Change Results																																																																																																																		
218	9.Electric Characteristics 9.1.4.12 Low Voltage Detection (Internal Voltage)	<p>Revised as below: Error)</p> <table border="1"> <thead> <tr> <th rowspan="2">Parameter</th> <th rowspan="2">Symbol</th> <th rowspan="2">Pin Name</th> <th rowspan="2">Conditions</th> <th colspan="3">Value</th> <th rowspan="2">Unit</th> <th rowspan="2">Remarks</th> </tr> <tr> <th>Min</th> <th>Typ</th> <th>Max</th> </tr> </thead> <tbody> <tr> <td>Supply voltage range</td> <td>V<sub>RDP5</sub></td> <td>-</td> <td>-</td> <td>1.05</td> <td>-</td> <td>1.21</td> <td>V</td> <td></td> </tr> <tr> <td>Detection voltage (before trimming)</td> <td>V<sub>RDLBT</sub></td> <td>-</td> <td>*1</td> <td>0.775</td> <td>0.875</td> <td>0.975</td> <td>V</td> <td>When power-supply voltage falls</td> </tr> <tr> <td>Detection voltage (after trimming)</td> <td>V<sub>RDLAT</sub></td> <td>-</td> <td>*1</td> <td>0.844</td> <td>0.875</td> <td>0.906</td> <td>V</td> <td>When power-supply voltage falls Typ±3.5%</td> </tr> <tr> <td>Hysteresis width</td> <td>V<sub>RHYS</sub></td> <td>-</td> <td>-</td> <td>-</td> <td>75</td> <td>-</td> <td>mV</td> <td>When power-supply voltage rises</td> </tr> <tr> <td>Low-voltage detection time</td> <td>TRd</td> <td>-</td> <td>-</td> <td>-</td> <td>-</td> <td>30</td> <td>µs</td> <td></td> </tr> </tbody> </table> <p>*1: If the power fluctuation time is less than the low-voltage detection time (TRd) and has passed the detection voltage range, the detection may occur or be canceled after the supply voltage has passed the detection voltage range.</p> <p>Correct)</p> <table border="1"> <thead> <tr> <th rowspan="2">Parameter</th> <th rowspan="2">Symbol</th> <th rowspan="2">Pin Name</th> <th rowspan="2">Conditions</th> <th colspan="3">Value</th> <th rowspan="2">Unit</th> <th rowspan="2">Remarks</th> </tr> <tr> <th>Min</th> <th>Typ</th> <th>Max</th> </tr> </thead> <tbody> <tr> <td>Supply voltage range</td> <td>V<sub>RDP5</sub></td> <td>-</td> <td>-</td> <td>1.05</td> <td>-</td> <td>1.21</td> <td>V</td> <td></td> </tr> <tr> <td>Detection voltage (before trimming)</td> <td>V<sub>RDLBT</sub></td> <td>-</td> <td>*1</td> <td>0.775</td> <td>0.875</td> <td>0.975</td> <td>V</td> <td>When power-supply voltage falls *3</td> </tr> <tr> <td>Detection voltage (after trimming)</td> <td>V<sub>RDLAT</sub></td> <td>-</td> <td>*1</td> <td>0.844</td> <td>0.875</td> <td>0.906</td> <td>V</td> <td>When power-supply voltage falls Typ±3.5% *2 *3</td> </tr> <tr> <td>Hysteresis width</td> <td>V<sub>RHYS</sub></td> <td>-</td> <td>-</td> <td>-</td> <td>75</td> <td>-</td> <td>mV</td> <td>When power-supply voltage rises</td> </tr> <tr> <td>Low-voltage detection time</td> <td>TRd</td> <td>-</td> <td>-</td> <td>-</td> <td>-</td> <td>30</td> <td>µs</td> <td>*4</td> </tr> </tbody> </table> <p>*1: If the power fluctuation time is less than the low-voltage detection time (TRd) and has passed the detection voltage range, the detection may occur or be canceled after the supply voltage has passed the detection voltage range.</p> <p>*2: This detection voltage level setting is below the minimum operation assurance voltage . Between this detection voltage and the minimum operation assurance voltage, MCU functions are not guaranteed except for the low voltage detector. Note that although the detection level is below the minimum operation guarantee voltage, the LVD reset factor flag is set as the voltage drops below the detection level.</p> <p>*3: This LVD cannot be used to reliably generate a reset before voltage dips below minimum guaranteed MCU operation voltage, as these detection levels are below the minimum guaranteed MCU operation voltage.</p> <p>*4: After the brown-out event where the voltage level dips below the detection threshold for less than this time, the detection may occur or be canceled.</p>	Parameter	Symbol	Pin Name	Conditions	Value			Unit	Remarks	Min	Typ	Max	Supply voltage range	V <sub>RDP5</sub>	-	-	1.05	-	1.21	V		Detection voltage (before trimming)	V <sub>RDLBT</sub>	-	*1	0.775	0.875	0.975	V	When power-supply voltage falls	Detection voltage (after trimming)	V <sub>RDLAT</sub>	-	*1	0.844	0.875	0.906	V	When power-supply voltage falls Typ±3.5%	Hysteresis width	V <sub>RHYS</sub>	-	-	-	75	-	mV	When power-supply voltage rises	Low-voltage detection time	TRd	-	-	-	-	30	µs		Parameter	Symbol	Pin Name	Conditions	Value			Unit	Remarks	Min	Typ	Max	Supply voltage range	V <sub>RDP5</sub>	-	-	1.05	-	1.21	V		Detection voltage (before trimming)	V <sub>RDLBT</sub>	-	*1	0.775	0.875	0.975	V	When power-supply voltage falls *3	Detection voltage (after trimming)	V <sub>RDLAT</sub>	-	*1	0.844	0.875	0.906	V	When power-supply voltage falls Typ±3.5% *2 *3	Hysteresis width	V <sub>RHYS</sub>	-	-	-	75	-	mV	When power-supply voltage rises	Low-voltage detection time	TRd	-	-	-	-	30	µs	*4
Parameter	Symbol	Pin Name					Conditions	Value				Unit	Remarks																																																																																																							
			Min	Typ	Max																																																																																																															
Supply voltage range	V <sub>RDP5</sub>	-	-	1.05	-	1.21	V																																																																																																													
Detection voltage (before trimming)	V <sub>RDLBT</sub>	-	*1	0.775	0.875	0.975	V	When power-supply voltage falls																																																																																																												
Detection voltage (after trimming)	V <sub>RDLAT</sub>	-	*1	0.844	0.875	0.906	V	When power-supply voltage falls Typ±3.5%																																																																																																												
Hysteresis width	V <sub>RHYS</sub>	-	-	-	75	-	mV	When power-supply voltage rises																																																																																																												
Low-voltage detection time	TRd	-	-	-	-	30	µs																																																																																																													
Parameter	Symbol	Pin Name	Conditions	Value			Unit	Remarks																																																																																																												
				Min	Typ	Max																																																																																																														
Supply voltage range	V <sub>RDP5</sub>	-	-	1.05	-	1.21	V																																																																																																													
Detection voltage (before trimming)	V <sub>RDLBT</sub>	-	*1	0.775	0.875	0.975	V	When power-supply voltage falls *3																																																																																																												
Detection voltage (after trimming)	V <sub>RDLAT</sub>	-	*1	0.844	0.875	0.906	V	When power-supply voltage falls Typ±3.5% *2 *3																																																																																																												
Hysteresis width	V <sub>RHYS</sub>	-	-	-	75	-	mV	When power-supply voltage rises																																																																																																												
Low-voltage detection time	TRd	-	-	-	-	30	µs	*4																																																																																																												

Page	Section	Change Results																																																																																																																																																																																																																															
219	9.Electric Characteristics 9.1.4.14 Display Controller	Revised as below: Error) (13-1) Display controller0 Timing (TTL mode)  Correct) (1) Display controller0 Timing (TTL mode)																																																																																																																																																																																																																															
224	9.Electric Characteristics 9.1.4.16 DDR-HSSPI	Revised as below: Error) (16-1) DDR-HSSPI Interface Timing (SDR mode) <table border="1" style="width: 100%; border-collapse: collapse;"> <thead> <tr> <th rowspan="2">Parameter</th> <th rowspan="2">Symbol</th> <th rowspan="2">Pin Name</th> <th rowspan="2">Conditions</th> <th colspan="2">Value</th> <th rowspan="2">Unit</th> <th rowspan="2">Remarks</th> </tr> <tr> <th>Min</th> <th>Max</th> </tr> </thead> <tbody> <tr> <td>HSSPI clock cycle</td> <td><math>t_{cyc}</math></td> <td>M_SCLK0</td> <td rowspan="9">(CL = 20pF, I<sub>OL</sub>=-10mA, I<sub>OH</sub>=10mA)</td> <td>10</td> <td>-</td> <td>ns</td> <td></td> </tr> <tr> <td>M_SCLK↑ -&gt; delayed sample clock↑</td> <td><math>t_{spcnt}</math></td> <td>-</td> <td>0</td> <td><math>t_{cyc}</math></td> <td>ns</td> <td></td> </tr> <tr> <td>M_SDATA -&gt; delayed sample clock↑</td> <td><math>t_{sdata}</math></td> <td>M_SDATA0_0-3 M_SDATA1_0-3</td> <td>3.5</td> <td>-</td> <td>ns</td> <td></td> </tr> <tr> <td>Input setup time</td> <td></td> <td></td> <td></td> <td></td> <td></td> <td></td> </tr> <tr> <td>delayed sample clock↑ -&gt; M_SDATA</td> <td><math>t_{hdata}</math></td> <td>M_SDATA0_0-3 M_SDATA1_0-3</td> <td>2.0</td> <td>-</td> <td>ns</td> <td></td> </tr> <tr> <td>Input hold time</td> <td></td> <td></td> <td></td> <td></td> <td></td> <td></td> </tr> <tr> <td>M_SCLK↑ -&gt; M_SDATA</td> <td><math>t_{oddata}</math></td> <td>M_SDATA0_0-3 M_SDATA1_0-3</td> <td>-</td> <td>6.5</td> <td>ns</td> <td><math>t_{cyc} - 3.5ns</math></td> </tr> <tr> <td>Output delay time</td> <td></td> <td></td> <td></td> <td></td> <td></td> <td></td> </tr> <tr> <td>M_SCLK↑ -&gt; M_SDATA</td> <td><math>t_{ohdata}</math></td> <td>M_SDATA0_0-3 M_SDATA1_0-3</td> <td>3.5</td> <td>-</td> <td>ns</td> <td></td> </tr> <tr> <td>Output hold time</td> <td></td> <td></td> <td></td> <td></td> <td></td> <td></td> </tr> <tr> <td>M_SCLK↑ -&gt; M_SSEL</td> <td><math>t_{odsel}</math></td> <td>M_SSEL0, 1</td> <td>-</td> <td>5.5</td> <td>ns</td> <td><math>t_{cyc} - 4.5ns</math></td> </tr> <tr> <td>Output delay time</td> <td></td> <td></td> <td></td> <td></td> <td></td> <td></td> </tr> <tr> <td>M_SCLK↑ -&gt; M_SSEL</td> <td><math>t_{ohsel}</math></td> <td>M_SSEL0, 1</td> <td>4.5</td> <td>-</td> <td>ns</td> <td></td> </tr> <tr> <td>Output hold time</td> <td></td> <td></td> <td></td> <td></td> <td></td> <td></td> </tr> </tbody> </table> <p><b>Notes: This is Target Spec.</b></p> <p>Correct)            (1)DDR-HSSPI Interface Timing (SDR mode)</p> <table border="1" style="width: 100%; border-collapse: collapse;"> <thead> <tr> <th rowspan="2">Parameter</th> <th rowspan="2">Symbol</th> <th rowspan="2">Pin Name</th> <th rowspan="2">Conditions</th> <th colspan="2">Value</th> <th rowspan="2">Unit</th> <th rowspan="2">Remarks</th> </tr> <tr> <th>Min</th> <th>Max</th> </tr> </thead> <tbody> <tr> <td>HSSPI clock cycle</td> <td><math>t_{cyc}</math></td> <td>M_SCLK0</td> <td rowspan="9">(CL = 20pF, I<sub>OL</sub>=-10mA, I<sub>OH</sub>=10mA)</td> <td>10</td> <td>-</td> <td rowspan="2">ns</td> <td rowspan="2">when Quad Page Program</td> </tr> <tr> <td></td> <td></td> <td></td> <td>20</td> <td>-</td> </tr> <tr> <td>M_SCLK↑ -&gt; delayed sample clock↑</td> <td><math>t_{spcnt}</math></td> <td>-</td> <td>0</td> <td>31.5</td> <td>ns</td> <td></td> </tr> <tr> <td>M_SDATA -&gt; M_SCLK↑</td> <td><math>t_{sdata}</math></td> <td>M_SDATA0_0-3 M_SDATA1_0-3</td> <td>*1</td> <td>-</td> <td>ns</td> <td></td> </tr> <tr> <td>Input setup time</td> <td></td> <td></td> <td></td> <td></td> <td></td> <td></td> </tr> <tr> <td>M_SCLK↑ -&gt; M_SDATA</td> <td><math>t_{hdata}</math></td> <td>M_SDATA0_0-3 M_SDATA1_0-3</td> <td>*1</td> <td>-</td> <td>ns</td> <td></td> </tr> <tr> <td>Input hold time</td> <td></td> <td></td> <td></td> <td></td> <td></td> <td></td> </tr> <tr> <td>M_SCLK↑ -&gt; M_SDATA</td> <td><math>t_{oddata}</math></td> <td>M_SDATA0_0-3 M_SDATA1_0-3</td> <td>-</td> <td><math>t_{cyc}/2 + 2</math></td> <td>ns</td> <td></td> </tr> <tr> <td>Output delay time</td> <td></td> <td></td> <td></td> <td></td> <td></td> <td></td> </tr> <tr> <td>M_SCLK↑ -&gt; M_SDATA</td> <td><math>t_{ohdata}</math></td> <td>M_SDATA0_0-3 M_SDATA1_0-3</td> <td><math>t_{cyc}/2 - 3</math></td> <td>-</td> <td>ns</td> <td></td> </tr> <tr> <td>Output hold time</td> <td></td> <td></td> <td></td> <td></td> <td></td> <td></td> </tr> <tr> <td>M_SCLK↑ -&gt; M_SSEL</td> <td><math>t_{odsel}</math></td> <td>M_SSEL0, 1</td> <td>-12.00+ (SS2CD+0.5)* <math>t_{cyc}</math></td> <td>-</td> <td>ns</td> <td></td> </tr> <tr> <td>Output delay time</td> <td></td> <td></td> <td></td> <td></td> <td></td> <td></td> </tr> <tr> <td>M_SCLK↑ -&gt; M_SSEL</td> <td><math>t_{ohsel}</math></td> <td>M_SSEL0, 1</td> <td><math>t_{cyc} - 2</math></td> <td>-</td> <td>ns</td> <td></td> </tr> <tr> <td>Output hold time</td> <td></td> <td></td> <td></td> <td></td> <td></td> <td></td> </tr> </tbody> </table> <p><b>Notes: This is Target Spec.</b></p> <ul style="list-style-type: none"> <li>- SS2CD [1:0] should be configured as 01, 10, or 11.</li> <li>- For *1, the delay of the delay sample clock can be configured (DLP function)..</li> </ul>	Parameter	Symbol	Pin Name	Conditions	Value		Unit	Remarks	Min	Max	HSSPI clock cycle	$t_{cyc}$	M_SCLK0	(CL = 20pF, I <sub>OL</sub> =-10mA, I <sub>OH</sub> =10mA)	10	-	ns		M_SCLK↑ -> delayed sample clock↑	$t_{spcnt}$	-	0	$t_{cyc}$	ns		M_SDATA -> delayed sample clock↑	$t_{sdata}$	M_SDATA0_0-3 M_SDATA1_0-3	3.5	-	ns		Input setup time							delayed sample clock↑ -> M_SDATA	$t_{hdata}$	M_SDATA0_0-3 M_SDATA1_0-3	2.0	-	ns		Input hold time							M_SCLK↑ -> M_SDATA	$t_{oddata}$	M_SDATA0_0-3 M_SDATA1_0-3	-	6.5	ns	$t_{cyc} - 3.5ns$	Output delay time							M_SCLK↑ -> M_SDATA	$t_{ohdata}$	M_SDATA0_0-3 M_SDATA1_0-3	3.5	-	ns		Output hold time							M_SCLK↑ -> M_SSEL	$t_{odsel}$	M_SSEL0, 1	-	5.5	ns	$t_{cyc} - 4.5ns$	Output delay time							M_SCLK↑ -> M_SSEL	$t_{ohsel}$	M_SSEL0, 1	4.5	-	ns		Output hold time							Parameter	Symbol	Pin Name	Conditions	Value		Unit	Remarks	Min	Max	HSSPI clock cycle	$t_{cyc}$	M_SCLK0	(CL = 20pF, I <sub>OL</sub> =-10mA, I <sub>OH</sub> =10mA)	10	-	ns	when Quad Page Program				20	-	M_SCLK↑ -> delayed sample clock↑	$t_{spcnt}$	-	0	31.5	ns		M_SDATA -> M_SCLK↑	$t_{sdata}$	M_SDATA0_0-3 M_SDATA1_0-3	*1	-	ns		Input setup time							M_SCLK↑ -> M_SDATA	$t_{hdata}$	M_SDATA0_0-3 M_SDATA1_0-3	*1	-	ns		Input hold time							M_SCLK↑ -> M_SDATA	$t_{oddata}$	M_SDATA0_0-3 M_SDATA1_0-3	-	$t_{cyc}/2 + 2$	ns		Output delay time							M_SCLK↑ -> M_SDATA	$t_{ohdata}$	M_SDATA0_0-3 M_SDATA1_0-3	$t_{cyc}/2 - 3$	-	ns		Output hold time							M_SCLK↑ -> M_SSEL	$t_{odsel}$	M_SSEL0, 1	-12.00+ (SS2CD+0.5)* $t_{cyc}$	-	ns		Output delay time							M_SCLK↑ -> M_SSEL	$t_{ohsel}$	M_SSEL0, 1	$t_{cyc} - 2$	-	ns		Output hold time						
Parameter	Symbol	Pin Name					Conditions	Value			Unit	Remarks																																																																																																																																																																																																																					
			Min	Max																																																																																																																																																																																																																													
HSSPI clock cycle	$t_{cyc}$	M_SCLK0	(CL = 20pF, I <sub>OL</sub> =-10mA, I <sub>OH</sub> =10mA)	10	-	ns																																																																																																																																																																																																																											
M_SCLK↑ -> delayed sample clock↑	$t_{spcnt}$	-		0	$t_{cyc}$	ns																																																																																																																																																																																																																											
M_SDATA -> delayed sample clock↑	$t_{sdata}$	M_SDATA0_0-3 M_SDATA1_0-3		3.5	-	ns																																																																																																																																																																																																																											
Input setup time																																																																																																																																																																																																																																	
delayed sample clock↑ -> M_SDATA	$t_{hdata}$	M_SDATA0_0-3 M_SDATA1_0-3		2.0	-	ns																																																																																																																																																																																																																											
Input hold time																																																																																																																																																																																																																																	
M_SCLK↑ -> M_SDATA	$t_{oddata}$	M_SDATA0_0-3 M_SDATA1_0-3		-	6.5	ns	$t_{cyc} - 3.5ns$																																																																																																																																																																																																																										
Output delay time																																																																																																																																																																																																																																	
M_SCLK↑ -> M_SDATA	$t_{ohdata}$	M_SDATA0_0-3 M_SDATA1_0-3		3.5	-	ns																																																																																																																																																																																																																											
Output hold time																																																																																																																																																																																																																																	
M_SCLK↑ -> M_SSEL	$t_{odsel}$	M_SSEL0, 1	-	5.5	ns	$t_{cyc} - 4.5ns$																																																																																																																																																																																																																											
Output delay time																																																																																																																																																																																																																																	
M_SCLK↑ -> M_SSEL	$t_{ohsel}$	M_SSEL0, 1	4.5	-	ns																																																																																																																																																																																																																												
Output hold time																																																																																																																																																																																																																																	
Parameter	Symbol	Pin Name	Conditions	Value		Unit	Remarks																																																																																																																																																																																																																										
				Min	Max																																																																																																																																																																																																																												
HSSPI clock cycle	$t_{cyc}$	M_SCLK0	(CL = 20pF, I <sub>OL</sub> =-10mA, I <sub>OH</sub> =10mA)	10	-	ns	when Quad Page Program																																																																																																																																																																																																																										
				20	-																																																																																																																																																																																																																												
M_SCLK↑ -> delayed sample clock↑	$t_{spcnt}$	-		0	31.5	ns																																																																																																																																																																																																																											
M_SDATA -> M_SCLK↑	$t_{sdata}$	M_SDATA0_0-3 M_SDATA1_0-3		*1	-	ns																																																																																																																																																																																																																											
Input setup time																																																																																																																																																																																																																																	
M_SCLK↑ -> M_SDATA	$t_{hdata}$	M_SDATA0_0-3 M_SDATA1_0-3		*1	-	ns																																																																																																																																																																																																																											
Input hold time																																																																																																																																																																																																																																	
M_SCLK↑ -> M_SDATA	$t_{oddata}$	M_SDATA0_0-3 M_SDATA1_0-3		-	$t_{cyc}/2 + 2$	ns																																																																																																																																																																																																																											
Output delay time																																																																																																																																																																																																																																	
M_SCLK↑ -> M_SDATA	$t_{ohdata}$	M_SDATA0_0-3 M_SDATA1_0-3	$t_{cyc}/2 - 3$	-	ns																																																																																																																																																																																																																												
Output hold time																																																																																																																																																																																																																																	
M_SCLK↑ -> M_SSEL	$t_{odsel}$	M_SSEL0, 1	-12.00+ (SS2CD+0.5)* $t_{cyc}$	-	ns																																																																																																																																																																																																																												
Output delay time																																																																																																																																																																																																																																	
M_SCLK↑ -> M_SSEL	$t_{ohsel}$	M_SSEL0, 1	$t_{cyc} - 2$	-	ns																																																																																																																																																																																																																												
Output hold time																																																																																																																																																																																																																																	

Page	Section	Change Results																																																																																																																																																																																																																										
225	9.Electric Characteristics 9.1.4.16 DDR-HSSPI	<p>Revised as below: Error) (16-2) DDR-HSSPI Interface Timing (DDR mode)</p> <table border="1"> <thead> <tr> <th rowspan="2">Parameter</th> <th rowspan="2">Symbol</th> <th rowspan="2">Pin Name</th> <th rowspan="2">Conditions</th> <th colspan="2">Value</th> <th rowspan="2">Unit</th> <th rowspan="2">Remarks</th> </tr> <tr> <th>Min</th> <th>Max</th> </tr> </thead> <tbody> <tr> <td>HSSPI clock cycle</td> <td><math>t_{cyc}</math></td> <td>M_SCLK0</td> <td rowspan="9">(CL = 20pF, <math>I_{OL}=-10mA</math>, <math>I_{OH}=10mA</math>),</td> <td>10</td> <td>-</td> <td>ns</td> <td></td> </tr> <tr> <td>M_SCLK↑ -&gt; delayed sample clock↑</td> <td><math>t_{spcnt}</math></td> <td></td> <td>0</td> <td><math>t_{cyc}</math></td> <td>ns</td> <td></td> </tr> <tr> <td>M_SDATA -&gt; delayed sample clock↑</td> <td><math>t_{sdata}</math></td> <td>M_SDATA0_0-3 M_SDATA1_0-3</td> <td>1.0</td> <td>-</td> <td>ns</td> <td></td> </tr> <tr> <td>Input setup time</td> <td></td> <td></td> <td></td> <td></td> <td></td> <td></td> </tr> <tr> <td>delayed sample clock↑ -&gt; M_SDATA</td> <td><math>t_{hdata}</math></td> <td>M_SDATA0_0-3 M_SDATA1_0-3</td> <td>1.0</td> <td>-</td> <td>ns</td> <td></td> </tr> <tr> <td>Input hold time</td> <td></td> <td></td> <td></td> <td></td> <td></td> <td></td> </tr> <tr> <td>M_SCLK↑ -&gt; M_SDATA</td> <td><math>t_{oddata}</math></td> <td>M_SDATA0_0-3 M_SDATA1_0-3</td> <td>-</td> <td>3.5</td> <td>ns</td> <td><math>t_{cyc}/2-1.5ns</math></td> </tr> <tr> <td>Output delay time</td> <td></td> <td></td> <td></td> <td></td> <td></td> <td></td> </tr> <tr> <td>M_SCLK↑ -&gt; M_SDATA</td> <td><math>t_{ohdata}</math></td> <td>M_SDATA0_0-3 M_SDATA1_0-3</td> <td>1.5</td> <td>-</td> <td>ns</td> <td></td> </tr> <tr> <td>Output hold time</td> <td></td> <td></td> <td></td> <td></td> <td></td> <td></td> </tr> <tr> <td>M_SCLK↑ -&gt; M_SSEL</td> <td><math>t_{odsel}</math></td> <td>M_SSEL0, 1</td> <td>-</td> <td>7.0</td> <td>ns</td> <td><math>t_{cyc}-3.0ns</math></td> </tr> <tr> <td>Output delay time</td> <td></td> <td></td> <td></td> <td></td> <td></td> <td></td> </tr> <tr> <td>M_SCLK↑ -&gt; M_SSEL</td> <td><math>t_{ohsel}</math></td> <td>M_SSEL0, 1</td> <td>3.0</td> <td>-</td> <td>ns</td> <td></td> </tr> <tr> <td>Output hold time</td> <td></td> <td></td> <td></td> <td></td> <td></td> <td></td> </tr> </tbody> </table> <p>Notes: <b>This is Target Spec.</b></p> <p>Correct) (2)DDR-HSSPI Interface Timing (DDR mode)</p> <table border="1"> <thead> <tr> <th rowspan="2">Parameter</th> <th rowspan="2">Symbol</th> <th rowspan="2">Pin Name</th> <th rowspan="2">Conditions</th> <th colspan="2">Value</th> <th rowspan="2">Unit</th> <th rowspan="2">Remarks</th> </tr> <tr> <th>Min</th> <th>Max</th> </tr> </thead> <tbody> <tr> <td>HSSPI clock cycle</td> <td><math>t_{cyc}</math></td> <td>M_SCLK0</td> <td rowspan="9">(CL = 20pF, <math>I_{OL}=-10mA</math>, <math>I_{OH}=10mA</math>),</td> <td>12.5</td> <td>-</td> <td>ns</td> <td></td> </tr> <tr> <td>M_SCLK↑ -&gt; delayed sample clock↑</td> <td><math>t_{spcnt}</math></td> <td></td> <td>0</td> <td>31.5</td> <td>ns</td> <td></td> </tr> <tr> <td>M_SDATA -&gt; M_SCLK↑</td> <td><math>t_{sdata}</math></td> <td>M_SDATA0_0-3 M_SDATA1_0-3</td> <td>*1</td> <td>-</td> <td>ns</td> <td></td> </tr> <tr> <td>Input setup time</td> <td></td> <td></td> <td></td> <td></td> <td></td> <td></td> </tr> <tr> <td>M_SCLK↑ -&gt; M_SDATA</td> <td><math>t_{hdata}</math></td> <td>M_SDATA0_0-3 M_SDATA1_0-3</td> <td>*1</td> <td>-</td> <td>ns</td> <td></td> </tr> <tr> <td>Input hold time</td> <td></td> <td></td> <td></td> <td></td> <td></td> <td></td> </tr> <tr> <td>M_SCLK↑ -&gt; M_SDATA</td> <td><math>t_{oddata}</math></td> <td>M_SDATA0_0-3 M_SDATA1_0-3</td> <td>-</td> <td><math>t_{cyc}/4 + 1.5</math></td> <td>ns</td> <td></td> </tr> <tr> <td>Output delay time</td> <td></td> <td></td> <td></td> <td></td> <td></td> <td></td> </tr> <tr> <td>M_SCLK↑ -&gt; M_SDATA</td> <td><math>t_{ohdata}</math></td> <td>M_SDATA0_0-3 M_SDATA1_0-3</td> <td><math>T_{cyc}/4 - 1.0</math></td> <td>-</td> <td>ns</td> <td></td> </tr> <tr> <td>Output hold time</td> <td></td> <td></td> <td></td> <td></td> <td></td> <td></td> </tr> <tr> <td>M_SCLK↑ -&gt; M_SSEL</td> <td><math>t_{odsel}</math></td> <td>M_SSEL0, 1</td> <td>-15.75+ <math>(SS2CD+0.5)*t_{cyc}</math></td> <td>-</td> <td>ns</td> <td></td> </tr> <tr> <td>Output delay time</td> <td></td> <td></td> <td></td> <td></td> <td></td> <td></td> </tr> <tr> <td>M_SCLK↑ -&gt; M_SSEL</td> <td><math>t_{ohsel}</math></td> <td>M_SSEL0, 1</td> <td><math>0.75*t_{cyc} - 2.0</math></td> <td>-</td> <td>ns</td> <td></td> </tr> <tr> <td>Output hold time</td> <td></td> <td></td> <td></td> <td></td> <td></td> <td></td> </tr> </tbody> </table> <p>Notes: <b>This is Target Spec.</b></p> <ul style="list-style-type: none"> <li>- SS2CD [1:0] should be configured as 01, 10, or 11.</li> <li>- For *1, the delay of the delay sample clock can be configured (DLP function)</li> </ul>	Parameter	Symbol	Pin Name	Conditions	Value		Unit	Remarks	Min	Max	HSSPI clock cycle	$t_{cyc}$	M_SCLK0	(CL = 20pF, $I_{OL}=-10mA$ , $I_{OH}=10mA$ ),	10	-	ns		M_SCLK↑ -> delayed sample clock↑	$t_{spcnt}$		0	$t_{cyc}$	ns		M_SDATA -> delayed sample clock↑	$t_{sdata}$	M_SDATA0_0-3 M_SDATA1_0-3	1.0	-	ns		Input setup time							delayed sample clock↑ -> M_SDATA	$t_{hdata}$	M_SDATA0_0-3 M_SDATA1_0-3	1.0	-	ns		Input hold time							M_SCLK↑ -> M_SDATA	$t_{oddata}$	M_SDATA0_0-3 M_SDATA1_0-3	-	3.5	ns	$t_{cyc}/2-1.5ns$	Output delay time							M_SCLK↑ -> M_SDATA	$t_{ohdata}$	M_SDATA0_0-3 M_SDATA1_0-3	1.5	-	ns		Output hold time							M_SCLK↑ -> M_SSEL	$t_{odsel}$	M_SSEL0, 1	-	7.0	ns	$t_{cyc}-3.0ns$	Output delay time							M_SCLK↑ -> M_SSEL	$t_{ohsel}$	M_SSEL0, 1	3.0	-	ns		Output hold time							Parameter	Symbol	Pin Name	Conditions	Value		Unit	Remarks	Min	Max	HSSPI clock cycle	$t_{cyc}$	M_SCLK0	(CL = 20pF, $I_{OL}=-10mA$ , $I_{OH}=10mA$ ),	12.5	-	ns		M_SCLK↑ -> delayed sample clock↑	$t_{spcnt}$		0	31.5	ns		M_SDATA -> M_SCLK↑	$t_{sdata}$	M_SDATA0_0-3 M_SDATA1_0-3	*1	-	ns		Input setup time							M_SCLK↑ -> M_SDATA	$t_{hdata}$	M_SDATA0_0-3 M_SDATA1_0-3	*1	-	ns		Input hold time							M_SCLK↑ -> M_SDATA	$t_{oddata}$	M_SDATA0_0-3 M_SDATA1_0-3	-	$t_{cyc}/4 + 1.5$	ns		Output delay time							M_SCLK↑ -> M_SDATA	$t_{ohdata}$	M_SDATA0_0-3 M_SDATA1_0-3	$T_{cyc}/4 - 1.0$	-	ns		Output hold time							M_SCLK↑ -> M_SSEL	$t_{odsel}$	M_SSEL0, 1	-15.75+ $(SS2CD+0.5)*t_{cyc}$	-	ns		Output delay time							M_SCLK↑ -> M_SSEL	$t_{ohsel}$	M_SSEL0, 1	$0.75*t_{cyc} - 2.0$	-	ns		Output hold time						
Parameter	Symbol	Pin Name					Conditions	Value			Unit	Remarks																																																																																																																																																																																																																
			Min	Max																																																																																																																																																																																																																								
HSSPI clock cycle	$t_{cyc}$	M_SCLK0	(CL = 20pF, $I_{OL}=-10mA$ , $I_{OH}=10mA$ ),	10	-	ns																																																																																																																																																																																																																						
M_SCLK↑ -> delayed sample clock↑	$t_{spcnt}$			0	$t_{cyc}$	ns																																																																																																																																																																																																																						
M_SDATA -> delayed sample clock↑	$t_{sdata}$	M_SDATA0_0-3 M_SDATA1_0-3		1.0	-	ns																																																																																																																																																																																																																						
Input setup time																																																																																																																																																																																																																												
delayed sample clock↑ -> M_SDATA	$t_{hdata}$	M_SDATA0_0-3 M_SDATA1_0-3		1.0	-	ns																																																																																																																																																																																																																						
Input hold time																																																																																																																																																																																																																												
M_SCLK↑ -> M_SDATA	$t_{oddata}$	M_SDATA0_0-3 M_SDATA1_0-3		-	3.5	ns	$t_{cyc}/2-1.5ns$																																																																																																																																																																																																																					
Output delay time																																																																																																																																																																																																																												
M_SCLK↑ -> M_SDATA	$t_{ohdata}$	M_SDATA0_0-3 M_SDATA1_0-3		1.5	-	ns																																																																																																																																																																																																																						
Output hold time																																																																																																																																																																																																																												
M_SCLK↑ -> M_SSEL	$t_{odsel}$	M_SSEL0, 1	-	7.0	ns	$t_{cyc}-3.0ns$																																																																																																																																																																																																																						
Output delay time																																																																																																																																																																																																																												
M_SCLK↑ -> M_SSEL	$t_{ohsel}$	M_SSEL0, 1	3.0	-	ns																																																																																																																																																																																																																							
Output hold time																																																																																																																																																																																																																												
Parameter	Symbol	Pin Name	Conditions	Value		Unit	Remarks																																																																																																																																																																																																																					
				Min	Max																																																																																																																																																																																																																							
HSSPI clock cycle	$t_{cyc}$	M_SCLK0	(CL = 20pF, $I_{OL}=-10mA$ , $I_{OH}=10mA$ ),	12.5	-	ns																																																																																																																																																																																																																						
M_SCLK↑ -> delayed sample clock↑	$t_{spcnt}$			0	31.5	ns																																																																																																																																																																																																																						
M_SDATA -> M_SCLK↑	$t_{sdata}$	M_SDATA0_0-3 M_SDATA1_0-3		*1	-	ns																																																																																																																																																																																																																						
Input setup time																																																																																																																																																																																																																												
M_SCLK↑ -> M_SDATA	$t_{hdata}$	M_SDATA0_0-3 M_SDATA1_0-3		*1	-	ns																																																																																																																																																																																																																						
Input hold time																																																																																																																																																																																																																												
M_SCLK↑ -> M_SDATA	$t_{oddata}$	M_SDATA0_0-3 M_SDATA1_0-3		-	$t_{cyc}/4 + 1.5$	ns																																																																																																																																																																																																																						
Output delay time																																																																																																																																																																																																																												
M_SCLK↑ -> M_SDATA	$t_{ohdata}$	M_SDATA0_0-3 M_SDATA1_0-3		$T_{cyc}/4 - 1.0$	-	ns																																																																																																																																																																																																																						
Output hold time																																																																																																																																																																																																																												
M_SCLK↑ -> M_SSEL	$t_{odsel}$	M_SSEL0, 1	-15.75+ $(SS2CD+0.5)*t_{cyc}$	-	ns																																																																																																																																																																																																																							
Output delay time																																																																																																																																																																																																																												
M_SCLK↑ -> M_SSEL	$t_{ohsel}$	M_SSEL0, 1	$0.75*t_{cyc} - 2.0$	-	ns																																																																																																																																																																																																																							
Output hold time																																																																																																																																																																																																																												

Page	Section	Change Results																																																																
227	9.Electric Characteristics 9.1.4.17 Hyper BUS	<p>Revised as below: Error)</p> <p>(16-1) Hyper Bus Write Timing (HyperFlash)</p> <table border="1"> <thead> <tr> <th rowspan="2">Parameter</th> <th rowspan="2">Symbol</th> <th rowspan="2">Pin Name</th> <th rowspan="2">Conditions</th> <th colspan="2">Value</th> <th rowspan="2">Unit</th> <th rowspan="2">Remarks</th> </tr> <tr> <th>Min</th> <th>Max</th> </tr> </thead> <tbody> <tr> <td>CS<math>\downarrow</math> -&gt; CK<math>\uparrow</math> Chip Select setup time</td> <td>t<sub>css</sub></td> <td>M_CS#_1,2</td> <td rowspan="2">(CL = 20pF, I<sub>OL</sub>=-10mA, I<sub>OH</sub>=10mA),</td> <td>3.0</td> <td>-</td> <td>ns</td> <td></td> </tr> <tr> <td>CK<math>\downarrow</math> -&gt; CS<math>\uparrow</math> Chip select hold time</td> <td>t<sub>csH</sub></td> <td>M_CS#_1,2</td> <td>0</td> <td>-</td> <td>ns</td> <td></td> </tr> </tbody> </table> <p>Correct)</p> <p>(1)Hyper Bus Write Timing (HyperFlash)</p> <table border="1"> <thead> <tr> <th rowspan="2">Parameter</th> <th rowspan="2">Symbol</th> <th rowspan="2">Pin Name</th> <th rowspan="2">Conditions</th> <th colspan="2">Value</th> <th rowspan="2">Unit</th> <th rowspan="2">Remarks</th> </tr> <tr> <th>Min</th> <th>Max</th> </tr> </thead> <tbody> <tr> <td>CS<math>\downarrow</math> -&gt; CK<math>\uparrow</math> Chip Select setup time</td> <td>t<sub>css</sub></td> <td>M_CS#_1,2</td> <td rowspan="2">(CL = 20pF, I<sub>OL</sub>=-10mA, I<sub>OH</sub>=10mA),</td> <td>t<sub>ckcyc</sub> - 2.0</td> <td>-</td> <td>ns</td> <td></td> </tr> <tr> <td>CK<math>\downarrow</math> -&gt; CS<math>\uparrow</math> Chip select hold time</td> <td>t<sub>csH</sub></td> <td>M_CS#_1,2</td> <td>t<sub>ckcyc</sub>/2</td> <td>-</td> <td>ns</td> <td></td> </tr> </tbody> </table>	Parameter	Symbol	Pin Name	Conditions	Value		Unit	Remarks	Min	Max	CS $\downarrow$ -> CK $\uparrow$ Chip Select setup time	t <sub>css</sub>	M_CS#_1,2	(CL = 20pF, I <sub>OL</sub> =-10mA, I <sub>OH</sub> =10mA),	3.0	-	ns		CK $\downarrow$ -> CS $\uparrow$ Chip select hold time	t <sub>csH</sub>	M_CS#_1,2	0	-	ns		Parameter	Symbol	Pin Name	Conditions	Value		Unit	Remarks	Min	Max	CS $\downarrow$ -> CK $\uparrow$ Chip Select setup time	t <sub>css</sub>	M_CS#_1,2	(CL = 20pF, I <sub>OL</sub> =-10mA, I <sub>OH</sub> =10mA),	t <sub>ckcyc</sub> - 2.0	-	ns		CK $\downarrow$ -> CS $\uparrow$ Chip select hold time	t <sub>csH</sub>	M_CS#_1,2	t <sub>ckcyc</sub> /2	-	ns															
Parameter	Symbol	Pin Name					Conditions	Value			Unit	Remarks																																																						
			Min	Max																																																														
CS $\downarrow$ -> CK $\uparrow$ Chip Select setup time	t <sub>css</sub>	M_CS#_1,2	(CL = 20pF, I <sub>OL</sub> =-10mA, I <sub>OH</sub> =10mA),	3.0	-	ns																																																												
CK $\downarrow$ -> CS $\uparrow$ Chip select hold time	t <sub>csH</sub>	M_CS#_1,2		0	-	ns																																																												
Parameter	Symbol	Pin Name	Conditions	Value		Unit	Remarks																																																											
				Min	Max																																																													
CS $\downarrow$ -> CK $\uparrow$ Chip Select setup time	t <sub>css</sub>	M_CS#_1,2	(CL = 20pF, I <sub>OL</sub> =-10mA, I <sub>OH</sub> =10mA),	t <sub>ckcyc</sub> - 2.0	-	ns																																																												
CK $\downarrow$ -> CS $\uparrow$ Chip select hold time	t <sub>csH</sub>	M_CS#_1,2		t <sub>ckcyc</sub> /2	-	ns																																																												
228	9.Electric Characteristics 9.1.4.17 Hyper BUS	<p>Revised as below: Error)</p> <p>(16-2) Hyper Bus Write Timing (HyperRAM)</p> <table border="1"> <thead> <tr> <th rowspan="2">Parameter</th> <th rowspan="2">Symbol</th> <th rowspan="2">Pin Name</th> <th rowspan="2">Conditions</th> <th colspan="2">Value</th> <th rowspan="2">Unit</th> <th rowspan="2">Remarks</th> </tr> <tr> <th>Min</th> <th>Max</th> </tr> </thead> <tbody> <tr> <td>CS<math>\downarrow</math> -&gt; CK<math>\uparrow</math> Chip Select setup time</td> <td>t<sub>css</sub></td> <td>M_CS#_1,2</td> <td rowspan="3">(CL = 20pF, I<sub>OL</sub>=-10mA, I<sub>OH</sub>=10mA),</td> <td>3.0</td> <td>-</td> <td>ns</td> <td></td> </tr> <tr> <td>CK<math>\downarrow</math> -&gt; CS<math>\uparrow</math> Chip select hold time</td> <td>t<sub>csH</sub></td> <td>M_CS#_1,2</td> <td>0</td> <td>-</td> <td>ns</td> <td></td> </tr> <tr> <td>RWDS<math>\downarrow</math>-&gt; CK<math>\downarrow</math> Data Mask Valid</td> <td>t<sub>dmv</sub></td> <td>M_RWDS</td> <td>0</td> <td>-</td> <td>ns</td> <td></td> </tr> </tbody> </table> <p>Correct)</p> <p>(2) Hyper Bus Write Timing (HyperRAM)</p> <table border="1"> <thead> <tr> <th rowspan="2">Parameter</th> <th rowspan="2">Symbol</th> <th rowspan="2">Pin Name</th> <th rowspan="2">Conditions</th> <th colspan="2">Value</th> <th rowspan="2">Unit</th> <th rowspan="2">Remarks</th> </tr> <tr> <th>Min</th> <th>Max</th> </tr> </thead> <tbody> <tr> <td>CS<math>\downarrow</math> -&gt; CK<math>\uparrow</math> Chip Select setup time</td> <td>t<sub>css</sub></td> <td>M_CS#_1,2</td> <td rowspan="3">(CL = 20pF, I<sub>OL</sub>=-10mA, I<sub>OH</sub>=10mA),</td> <td>t<sub>ckcyc</sub> - 2.0</td> <td>-</td> <td>ns</td> <td></td> </tr> <tr> <td>CK<math>\downarrow</math> -&gt; CS<math>\uparrow</math> Chip select hold time</td> <td>t<sub>csH</sub></td> <td>M_CS#_1,2</td> <td>t<sub>ckcyc</sub>/2</td> <td>-</td> <td>ns</td> <td></td> </tr> <tr> <td>RWDS<math>\downarrow</math>-&gt; CK<math>\downarrow</math> Data Mask Valid</td> <td>t<sub>dmv</sub></td> <td>M_RWDS</td> <td>1</td> <td>-</td> <td>ns</td> <td></td> </tr> </tbody> </table>	Parameter	Symbol	Pin Name	Conditions	Value		Unit	Remarks	Min	Max	CS $\downarrow$ -> CK $\uparrow$ Chip Select setup time	t <sub>css</sub>	M_CS#_1,2	(CL = 20pF, I <sub>OL</sub> =-10mA, I <sub>OH</sub> =10mA),	3.0	-	ns		CK $\downarrow$ -> CS $\uparrow$ Chip select hold time	t <sub>csH</sub>	M_CS#_1,2	0	-	ns		RWDS $\downarrow$ -> CK $\downarrow$ Data Mask Valid	t <sub>dmv</sub>	M_RWDS	0	-	ns		Parameter	Symbol	Pin Name	Conditions	Value		Unit	Remarks	Min	Max	CS $\downarrow$ -> CK $\uparrow$ Chip Select setup time	t <sub>css</sub>	M_CS#_1,2	(CL = 20pF, I <sub>OL</sub> =-10mA, I <sub>OH</sub> =10mA),	t <sub>ckcyc</sub> - 2.0	-	ns		CK $\downarrow$ -> CS $\uparrow$ Chip select hold time	t <sub>csH</sub>	M_CS#_1,2	t <sub>ckcyc</sub> /2	-	ns		RWDS $\downarrow$ -> CK $\downarrow$ Data Mask Valid	t <sub>dmv</sub>	M_RWDS	1	-	ns	
Parameter	Symbol	Pin Name					Conditions	Value			Unit	Remarks																																																						
			Min	Max																																																														
CS $\downarrow$ -> CK $\uparrow$ Chip Select setup time	t <sub>css</sub>	M_CS#_1,2	(CL = 20pF, I <sub>OL</sub> =-10mA, I <sub>OH</sub> =10mA),	3.0	-	ns																																																												
CK $\downarrow$ -> CS $\uparrow$ Chip select hold time	t <sub>csH</sub>	M_CS#_1,2		0	-	ns																																																												
RWDS $\downarrow$ -> CK $\downarrow$ Data Mask Valid	t <sub>dmv</sub>	M_RWDS		0	-	ns																																																												
Parameter	Symbol	Pin Name	Conditions	Value		Unit	Remarks																																																											
				Min	Max																																																													
CS $\downarrow$ -> CK $\uparrow$ Chip Select setup time	t <sub>css</sub>	M_CS#_1,2	(CL = 20pF, I <sub>OL</sub> =-10mA, I <sub>OH</sub> =10mA),	t <sub>ckcyc</sub> - 2.0	-	ns																																																												
CK $\downarrow$ -> CS $\uparrow$ Chip select hold time	t <sub>csH</sub>	M_CS#_1,2		t <sub>ckcyc</sub> /2	-	ns																																																												
RWDS $\downarrow$ -> CK $\downarrow$ Data Mask Valid	t <sub>dmv</sub>	M_RWDS		1	-	ns																																																												

Page	Section	Change Results																																																																																																										
229	9.Electric Characteristics 9.1.4.17 Hyper BUS	<p>Revised as below: Error)</p> <p>(16-3) Hyper Bus Read Timing (HyperFlash)</p> <table border="1"> <thead> <tr> <th rowspan="2">Parameter</th> <th rowspan="2">Symbol</th> <th rowspan="2">Pin Name</th> <th rowspan="2">Conditions</th> <th colspan="2">Value</th> <th rowspan="2">Unit</th> <th rowspan="2">Remarks</th> </tr> <tr> <th>Min</th> <th>Max</th> </tr> </thead> <tbody> <tr> <td>CS<math>\uparrow</math> <math>\rightarrow</math> CK<math>\uparrow</math> Chip Select setup time</td> <td>t<sub>css</sub></td> <td>M_CS#_1,2</td> <td rowspan="7">(CL = 20pF, I<sub>OL</sub>=-10mA, I<sub>OH</sub>=10mA),</td> <td>3.0</td> <td>-</td> <td>ns</td> <td></td> </tr> <tr> <td>DQ <math>\rightarrow</math> CK<math>\uparrow</math><math>\downarrow</math> Input setup time</td> <td>t<sub>is</sub></td> <td>M_DQ7-0</td> <td>1.25</td> <td>-</td> <td>ns</td> <td></td> </tr> <tr> <td>CK<math>\uparrow</math> <math>\rightarrow</math> DQ Input hold time</td> <td>t<sub>ih</sub></td> <td>M_DQ7-0</td> <td>1.25</td> <td>-</td> <td>ns</td> <td></td> </tr> <tr> <td>CK<math>\downarrow</math> <math>\rightarrow</math> CS<math>\uparrow</math> Chip select hold time</td> <td>t<sub>csH</sub></td> <td>M_CS#_1,2</td> <td>0</td> <td>-</td> <td>ns</td> <td></td> </tr> <tr> <td>RDS<math>\uparrow</math> <math>\downarrow</math> &gt; DQ (valid) RDS transition to DQ valid</td> <td>t<sub>bss</sub></td> <td>M_DQ7-0</td> <td>-0.8</td> <td>+0.8</td> <td>ns</td> <td></td> </tr> <tr> <td>RDS<math>\uparrow</math> <math>\downarrow</math> &gt; DQ (invalid) RDS transition to DQ invalid</td> <td>t<sub>bsh</sub></td> <td>M_DQ7-0</td> <td>-0.8</td> <td>+0.8</td> <td>ns</td> <td></td> </tr> </tbody> </table> <p>Correct)</p> <p>(3) Hyper Bus Read Timing (HyperFlash)</p> <table border="1"> <thead> <tr> <th rowspan="2">Parameter</th> <th rowspan="2">Symbol</th> <th rowspan="2">Pin Name</th> <th rowspan="2">Conditions</th> <th colspan="2">Value</th> <th rowspan="2">Unit</th> <th rowspan="2">Remarks</th> </tr> <tr> <th>Min</th> <th>Max</th> </tr> </thead> <tbody> <tr> <td>CS<math>\downarrow</math> <math>\rightarrow</math> CK<math>\uparrow</math> Chip Select setup time</td> <td>t<sub>css</sub></td> <td>M_CS#_1,2</td> <td rowspan="7">(CL = 20pF, I<sub>OL</sub>=-10mA, I<sub>OH</sub>=10mA),</td> <td>t<sub>RDS</sub> / 2</td> <td>-</td> <td>ns</td> <td></td> </tr> <tr> <td>DQ <math>\rightarrow</math> CK<math>\uparrow</math><math>\downarrow</math> Setup time</td> <td>t<sub>is</sub></td> <td>M_DQ7-0</td> <td>1.25</td> <td>-</td> <td>ns</td> <td></td> </tr> <tr> <td>CK<math>\uparrow</math> <math>\rightarrow</math> DQ Hold time</td> <td>t<sub>ih</sub></td> <td>M_DQ7-0</td> <td>1.25</td> <td>-</td> <td>ns</td> <td></td> </tr> <tr> <td>CK<math>\downarrow</math> <math>\rightarrow</math> CS<math>\uparrow</math> Chip select hold time</td> <td>t<sub>csH</sub></td> <td>M_CS#_1,2</td> <td>t<sub>RDS</sub> / 2</td> <td>-</td> <td>ns</td> <td></td> </tr> <tr> <td>RDS<math>\uparrow</math> <math>\downarrow</math> &gt; DQ Setup time</td> <td>t<sub>bss</sub></td> <td>M_DQ7-0</td> <td>-0.8</td> <td>-</td> <td>ns</td> <td></td> </tr> <tr> <td>RDS<math>\uparrow</math> <math>\downarrow</math> &gt; DQ Hold time</td> <td>t<sub>bsh</sub></td> <td>M_DQ7-0</td> <td>-0.8</td> <td>-</td> <td>ns</td> <td></td> </tr> </tbody> </table>	Parameter	Symbol	Pin Name	Conditions	Value		Unit	Remarks	Min	Max	CS $\uparrow$ $\rightarrow$ CK $\uparrow$ Chip Select setup time	t <sub>css</sub>	M_CS#_1,2	(CL = 20pF, I <sub>OL</sub> =-10mA, I <sub>OH</sub> =10mA),	3.0	-	ns		DQ $\rightarrow$ CK $\uparrow$ $\downarrow$ Input setup time	t <sub>is</sub>	M_DQ7-0	1.25	-	ns		CK $\uparrow$ $\rightarrow$ DQ Input hold time	t <sub>ih</sub>	M_DQ7-0	1.25	-	ns		CK $\downarrow$ $\rightarrow$ CS $\uparrow$ Chip select hold time	t <sub>csH</sub>	M_CS#_1,2	0	-	ns		RDS $\uparrow$ $\downarrow$ > DQ (valid) RDS transition to DQ valid	t <sub>bss</sub>	M_DQ7-0	-0.8	+0.8	ns		RDS $\uparrow$ $\downarrow$ > DQ (invalid) RDS transition to DQ invalid	t <sub>bsh</sub>	M_DQ7-0	-0.8	+0.8	ns		Parameter	Symbol	Pin Name	Conditions	Value		Unit	Remarks	Min	Max	CS $\downarrow$ $\rightarrow$ CK $\uparrow$ Chip Select setup time	t <sub>css</sub>	M_CS#_1,2	(CL = 20pF, I <sub>OL</sub> =-10mA, I <sub>OH</sub> =10mA),	t <sub>RDS</sub> / 2	-	ns		DQ $\rightarrow$ CK $\uparrow$ $\downarrow$ Setup time	t <sub>is</sub>	M_DQ7-0	1.25	-	ns		CK $\uparrow$ $\rightarrow$ DQ Hold time	t <sub>ih</sub>	M_DQ7-0	1.25	-	ns		CK $\downarrow$ $\rightarrow$ CS $\uparrow$ Chip select hold time	t <sub>csH</sub>	M_CS#_1,2	t <sub>RDS</sub> / 2	-	ns		RDS $\uparrow$ $\downarrow$ > DQ Setup time	t <sub>bss</sub>	M_DQ7-0	-0.8	-	ns		RDS $\uparrow$ $\downarrow$ > DQ Hold time	t <sub>bsh</sub>	M_DQ7-0	-0.8	-	ns	
Parameter	Symbol	Pin Name					Conditions	Value			Unit	Remarks																																																																																																
			Min	Max																																																																																																								
CS $\uparrow$ $\rightarrow$ CK $\uparrow$ Chip Select setup time	t <sub>css</sub>	M_CS#_1,2	(CL = 20pF, I <sub>OL</sub> =-10mA, I <sub>OH</sub> =10mA),	3.0	-	ns																																																																																																						
DQ $\rightarrow$ CK $\uparrow$ $\downarrow$ Input setup time	t <sub>is</sub>	M_DQ7-0		1.25	-	ns																																																																																																						
CK $\uparrow$ $\rightarrow$ DQ Input hold time	t <sub>ih</sub>	M_DQ7-0		1.25	-	ns																																																																																																						
CK $\downarrow$ $\rightarrow$ CS $\uparrow$ Chip select hold time	t <sub>csH</sub>	M_CS#_1,2		0	-	ns																																																																																																						
RDS $\uparrow$ $\downarrow$ > DQ (valid) RDS transition to DQ valid	t <sub>bss</sub>	M_DQ7-0		-0.8	+0.8	ns																																																																																																						
RDS $\uparrow$ $\downarrow$ > DQ (invalid) RDS transition to DQ invalid	t <sub>bsh</sub>	M_DQ7-0		-0.8	+0.8	ns																																																																																																						
Parameter	Symbol	Pin Name		Conditions	Value		Unit	Remarks																																																																																																				
			Min		Max																																																																																																							
CS $\downarrow$ $\rightarrow$ CK $\uparrow$ Chip Select setup time	t <sub>css</sub>	M_CS#_1,2	(CL = 20pF, I <sub>OL</sub> =-10mA, I <sub>OH</sub> =10mA),	t <sub>RDS</sub> / 2	-	ns																																																																																																						
DQ $\rightarrow$ CK $\uparrow$ $\downarrow$ Setup time	t <sub>is</sub>	M_DQ7-0		1.25	-	ns																																																																																																						
CK $\uparrow$ $\rightarrow$ DQ Hold time	t <sub>ih</sub>	M_DQ7-0		1.25	-	ns																																																																																																						
CK $\downarrow$ $\rightarrow$ CS $\uparrow$ Chip select hold time	t <sub>csH</sub>	M_CS#_1,2		t <sub>RDS</sub> / 2	-	ns																																																																																																						
RDS $\uparrow$ $\downarrow$ > DQ Setup time	t <sub>bss</sub>	M_DQ7-0		-0.8	-	ns																																																																																																						
RDS $\uparrow$ $\downarrow$ > DQ Hold time	t <sub>bsh</sub>	M_DQ7-0		-0.8	-	ns																																																																																																						

Page	Section	Change Results																																																																																																																																						
230	9.Electric Characteristics 9.1.4.17 Hyper BUS	<p>Revised as below: Error)</p> <p>(16-4) Hyper Bus Read Timing (HyperRAM)</p> <table border="1"> <thead> <tr> <th rowspan="2">Parameter</th> <th rowspan="2">Symbol</th> <th rowspan="2">Pin Name</th> <th rowspan="2">Conditions</th> <th colspan="2">Value</th> <th rowspan="2">Unit</th> <th rowspan="2">Remarks</th> </tr> <tr> <th>Min</th> <th>Max</th> </tr> </thead> <tbody> <tr> <td>CS<math>\downarrow</math> -&gt; CK<math>\uparrow</math> Chip Select setup time</td> <td>t<sub>css</sub></td> <td>M_CS#_1,2</td> <td rowspan="9">(CL = 20pF, I<sub>OL</sub>=-10mA, I<sub>OH</sub>=10mA),</td> <td>3.0</td> <td>-</td> <td>ns</td> <td></td> </tr> <tr> <td>DQ -&gt; CK<math>\uparrow</math><math>\downarrow</math> Input setup time</td> <td>t<sub>is</sub></td> <td>M_DQ7-0</td> <td>1.25</td> <td>-</td> <td>ns</td> <td></td> </tr> <tr> <td>CK<math>\uparrow</math> -&gt; DQ Input hold time</td> <td>t<sub>ih</sub></td> <td>M_DQ7-0</td> <td>1.25</td> <td>-</td> <td>ns</td> <td></td> </tr> <tr> <td>CK<math>\downarrow</math> -&gt; CS<math>\uparrow</math> Chip select hold time</td> <td>t<sub>csh</sub></td> <td>M_CS#_1,2</td> <td>0</td> <td>-</td> <td>ns</td> <td></td> </tr> <tr> <td>RWDS<math>\uparrow</math><math>\downarrow</math> &gt; DQ (valid) RWDS transition to DQ valid</td> <td>t<sub>dss</sub></td> <td>M_DQ7-0</td> <td>-0.8</td> <td>+0.8</td> <td>ns</td> <td></td> </tr> <tr> <td>RWDS<math>\uparrow</math><math>\downarrow</math> &gt; DQ (invalid) RWDS transition to DQ invalid</td> <td>t<sub>dsh</sub></td> <td>M_DQ7-0</td> <td>-0.8</td> <td>+0.8</td> <td>ns</td> <td></td> </tr> <tr> <td>CK<math>\uparrow</math> -&gt; RWDS<math>\uparrow</math><math>\downarrow</math> Refresh Indicator Valid</td> <td>t<sub>riv</sub></td> <td>M_RWDS</td> <td>-</td> <td>6</td> <td>ns</td> <td></td> </tr> <tr> <td>CK<math>\uparrow</math> -&gt; RWDS(Hi-z) Refresh Indicator Hold</td> <td>t<sub>rih</sub></td> <td>M_RWDS</td> <td>0</td> <td>-</td> <td>ns</td> <td></td> </tr> </tbody> </table> <p>Correct)</p> <p>(4) Hyper Bus Read Timing (HyperRAM)</p> <table border="1"> <thead> <tr> <th rowspan="2">Parameter</th> <th rowspan="2">Symbol</th> <th rowspan="2">Pin Name</th> <th rowspan="2">Conditions</th> <th colspan="2">Value</th> <th rowspan="2">Unit</th> <th rowspan="2">Remarks</th> </tr> <tr> <th>Min</th> <th>Max</th> </tr> </thead> <tbody> <tr> <td>CS<math>\downarrow</math> -&gt; CK<math>\uparrow</math> Chip Select setup time</td> <td>t<sub>css</sub></td> <td>M_CS#_1,2</td> <td rowspan="9">(CL = 20pF, I<sub>OL</sub>=-10mA, I<sub>OH</sub>=10mA),</td> <td>t<sub>rdscyc</sub> -2.0</td> <td>-</td> <td>ns</td> <td></td> </tr> <tr> <td>DQ -&gt; CK<math>\uparrow</math><math>\downarrow</math> Setup time</td> <td>t<sub>is</sub></td> <td>M_DQ7-0</td> <td>1.25</td> <td>-</td> <td>ns</td> <td></td> </tr> <tr> <td>CK<math>\uparrow</math> -&gt; DQ Hold time</td> <td>t<sub>ih</sub></td> <td>M_DQ7-0</td> <td>1.25</td> <td>-</td> <td>ns</td> <td></td> </tr> <tr> <td>CK<math>\downarrow</math> -&gt; CS<math>\uparrow</math> Chip select hold time</td> <td>t<sub>csh</sub></td> <td>M_CS#_1,2</td> <td>t<sub>rdscyc</sub> /2</td> <td>-</td> <td>ns</td> <td></td> </tr> <tr> <td>RWDS<math>\uparrow</math><math>\downarrow</math> &gt; DQ (valid) Setup time</td> <td>t<sub>dss</sub></td> <td>M_DQ7-0</td> <td>-0.8</td> <td>-</td> <td>ns</td> <td></td> </tr> <tr> <td>RWDS<math>\uparrow</math><math>\downarrow</math> &gt; DQ (invalid) Hold time</td> <td>t<sub>dsh</sub></td> <td>M_DQ7-0</td> <td>-0.8</td> <td>-</td> <td>ns</td> <td></td> </tr> <tr> <td>CK<math>\uparrow</math> -&gt; RWDS<math>\uparrow</math><math>\downarrow</math> Refresh Indicator Valid</td> <td>t<sub>riv</sub></td> <td>M_RWDS</td> <td>-</td> <td>6</td> <td>ns</td> <td></td> </tr> <tr> <td>CK<math>\uparrow</math> -&gt; RWDS(Hi-z) Refresh Indicator Hold</td> <td>t<sub>rih</sub></td> <td>M_RWDS</td> <td>0</td> <td>-</td> <td>ns</td> <td></td> </tr> </tbody> </table>	Parameter	Symbol	Pin Name	Conditions	Value		Unit	Remarks	Min	Max	CS $\downarrow$ -> CK $\uparrow$ Chip Select setup time	t <sub>css</sub>	M_CS#_1,2	(CL = 20pF, I <sub>OL</sub> =-10mA, I <sub>OH</sub> =10mA),	3.0	-	ns		DQ -> CK $\uparrow$ $\downarrow$ Input setup time	t <sub>is</sub>	M_DQ7-0	1.25	-	ns		CK $\uparrow$ -> DQ Input hold time	t <sub>ih</sub>	M_DQ7-0	1.25	-	ns		CK $\downarrow$ -> CS $\uparrow$ Chip select hold time	t <sub>csh</sub>	M_CS#_1,2	0	-	ns		RWDS $\uparrow$ $\downarrow$ > DQ (valid) RWDS transition to DQ valid	t <sub>dss</sub>	M_DQ7-0	-0.8	+0.8	ns		RWDS $\uparrow$ $\downarrow$ > DQ (invalid) RWDS transition to DQ invalid	t <sub>dsh</sub>	M_DQ7-0	-0.8	+0.8	ns		CK $\uparrow$ -> RWDS $\uparrow$ $\downarrow$ Refresh Indicator Valid	t <sub>riv</sub>	M_RWDS	-	6	ns		CK $\uparrow$ -> RWDS(Hi-z) Refresh Indicator Hold	t <sub>rih</sub>	M_RWDS	0	-	ns		Parameter	Symbol	Pin Name	Conditions	Value		Unit	Remarks	Min	Max	CS $\downarrow$ -> CK $\uparrow$ Chip Select setup time	t <sub>css</sub>	M_CS#_1,2	(CL = 20pF, I <sub>OL</sub> =-10mA, I <sub>OH</sub> =10mA),	t <sub>rdscyc</sub> -2.0	-	ns		DQ -> CK $\uparrow$ $\downarrow$ Setup time	t <sub>is</sub>	M_DQ7-0	1.25	-	ns		CK $\uparrow$ -> DQ Hold time	t <sub>ih</sub>	M_DQ7-0	1.25	-	ns		CK $\downarrow$ -> CS $\uparrow$ Chip select hold time	t <sub>csh</sub>	M_CS#_1,2	t <sub>rdscyc</sub> /2	-	ns		RWDS $\uparrow$ $\downarrow$ > DQ (valid) Setup time	t <sub>dss</sub>	M_DQ7-0	-0.8	-	ns		RWDS $\uparrow$ $\downarrow$ > DQ (invalid) Hold time	t <sub>dsh</sub>	M_DQ7-0	-0.8	-	ns		CK $\uparrow$ -> RWDS $\uparrow$ $\downarrow$ Refresh Indicator Valid	t <sub>riv</sub>	M_RWDS	-	6	ns		CK $\uparrow$ -> RWDS(Hi-z) Refresh Indicator Hold	t <sub>rih</sub>	M_RWDS	0	-	ns	
Parameter	Symbol	Pin Name					Conditions	Value			Unit	Remarks																																																																																																																												
			Min	Max																																																																																																																																				
CS $\downarrow$ -> CK $\uparrow$ Chip Select setup time	t <sub>css</sub>	M_CS#_1,2	(CL = 20pF, I <sub>OL</sub> =-10mA, I <sub>OH</sub> =10mA),	3.0	-	ns																																																																																																																																		
DQ -> CK $\uparrow$ $\downarrow$ Input setup time	t <sub>is</sub>	M_DQ7-0		1.25	-	ns																																																																																																																																		
CK $\uparrow$ -> DQ Input hold time	t <sub>ih</sub>	M_DQ7-0		1.25	-	ns																																																																																																																																		
CK $\downarrow$ -> CS $\uparrow$ Chip select hold time	t <sub>csh</sub>	M_CS#_1,2		0	-	ns																																																																																																																																		
RWDS $\uparrow$ $\downarrow$ > DQ (valid) RWDS transition to DQ valid	t <sub>dss</sub>	M_DQ7-0		-0.8	+0.8	ns																																																																																																																																		
RWDS $\uparrow$ $\downarrow$ > DQ (invalid) RWDS transition to DQ invalid	t <sub>dsh</sub>	M_DQ7-0		-0.8	+0.8	ns																																																																																																																																		
CK $\uparrow$ -> RWDS $\uparrow$ $\downarrow$ Refresh Indicator Valid	t <sub>riv</sub>	M_RWDS		-	6	ns																																																																																																																																		
CK $\uparrow$ -> RWDS(Hi-z) Refresh Indicator Hold	t <sub>rih</sub>	M_RWDS		0	-	ns																																																																																																																																		
Parameter	Symbol	Pin Name		Conditions	Value		Unit	Remarks																																																																																																																																
			Min		Max																																																																																																																																			
CS $\downarrow$ -> CK $\uparrow$ Chip Select setup time	t <sub>css</sub>	M_CS#_1,2	(CL = 20pF, I <sub>OL</sub> =-10mA, I <sub>OH</sub> =10mA),	t <sub>rdscyc</sub> -2.0	-	ns																																																																																																																																		
DQ -> CK $\uparrow$ $\downarrow$ Setup time	t <sub>is</sub>	M_DQ7-0		1.25	-	ns																																																																																																																																		
CK $\uparrow$ -> DQ Hold time	t <sub>ih</sub>	M_DQ7-0		1.25	-	ns																																																																																																																																		
CK $\downarrow$ -> CS $\uparrow$ Chip select hold time	t <sub>csh</sub>	M_CS#_1,2		t <sub>rdscyc</sub> /2	-	ns																																																																																																																																		
RWDS $\uparrow$ $\downarrow$ > DQ (valid) Setup time	t <sub>dss</sub>	M_DQ7-0		-0.8	-	ns																																																																																																																																		
RWDS $\uparrow$ $\downarrow$ > DQ (invalid) Hold time	t <sub>dsh</sub>	M_DQ7-0		-0.8	-	ns																																																																																																																																		
CK $\uparrow$ -> RWDS $\uparrow$ $\downarrow$ Refresh Indicator Valid	t <sub>riv</sub>	M_RWDS		-	6	ns																																																																																																																																		
CK $\uparrow$ -> RWDS(Hi-z) Refresh Indicator Hold	t <sub>rih</sub>	M_RWDS		0	-	ns																																																																																																																																		

Page	Section	Change Results																																																																																																																
234	9.Electric Characteristics 9.1.4.19 MediaLB	<p>Revised as below: Error)</p> <p>(19-1) MediaLB Input Timing</p> <table border="1"> <thead> <tr> <th rowspan="2">Parameter</th> <th rowspan="2">Symbol</th> <th rowspan="2">Pin Name</th> <th rowspan="2">Conditions</th> <th colspan="2">Value</th> <th rowspan="2">Unit</th> <th rowspan="2">Remarks</th> </tr> <tr> <th>Min</th> <th>Max</th> </tr> </thead> <tbody> <tr> <td>MLBCLK cycle</td> <td>t<sub>mckc</sub></td> <td>MLBCLK</td> <td rowspan="2">-</td> <td>19.53</td> <td>-</td> <td>ns</td> <td rowspan="2">-</td> </tr> <tr> <td>MLBSIG, MLBDAT Input hold</td> <td>t<sub>dthmcf</sub></td> <td>MLBSIG MLBDAT</td> <td>0</td> <td>-</td> <td>ns</td> </tr> </tbody> </table> <p>Notes: This is Target Spec.</p> <p>(19-2) MediaLB Output Timing</p> <table border="1"> <thead> <tr> <th rowspan="2">Parameter</th> <th rowspan="2">Symbol</th> <th rowspan="2">Pin Name</th> <th rowspan="2">Conditions</th> <th colspan="2">Value</th> <th rowspan="2">Unit</th> <th rowspan="2">Remarks</th> </tr> <tr> <th>Min</th> <th>Max</th> </tr> </thead> <tbody> <tr> <td>MLBCLK cycle</td> <td>t<sub>mckc</sub></td> <td>MLBCLK</td> <td rowspan="3">(CL = 20pF, I<sub>OL</sub>=-6mA, I<sub>OH</sub>=6mA),</td> <td>19.53</td> <td>-</td> <td>ns</td> <td>-</td> </tr> <tr> <td>MLBSIG, MLBDAT output stop</td> <td>t<sub>mctdz</sub></td> <td>MLBSIG MLBDAT</td> <td>10.73</td> <td>-</td> <td>ns</td> <td>t<sub>mckc</sub> -8.8ns</td> </tr> <tr> <td>MLBSIG, MLBDAT output delay</td> <td>t<sub>dout</sub></td> <td>MLBSIG MLBDAT</td> <td>0</td> <td>8.8</td> <td>ns</td> <td>-</td> </tr> </tbody> </table> <p>Notes: This is Target Spec.</p> <p>Correct)</p> <p>(1) MediaLB Input Timing</p> <table border="1"> <thead> <tr> <th rowspan="2">Parameter</th> <th rowspan="2">Symbol</th> <th rowspan="2">Pin Name</th> <th rowspan="2">Conditions</th> <th colspan="2">Value</th> <th rowspan="2">Unit</th> <th rowspan="2">Remarks</th> </tr> <tr> <th>Min</th> <th>Max</th> </tr> </thead> <tbody> <tr> <td>MLBCLK cycle</td> <td>t<sub>mckc</sub></td> <td>MLBCLK</td> <td rowspan="2">-</td> <td>40.0</td> <td>-</td> <td>ns</td> <td rowspan="2">-</td> </tr> <tr> <td>MLBSIG, MLBDAT Input hold</td> <td>t<sub>dthmcf</sub></td> <td>MLBSIG MLBDAT</td> <td>4.0</td> <td>-</td> <td>ns</td> </tr> </tbody> </table> <p>Notes: This is Target Spec.</p> <p>- CLK_HAPP1B0(internal) frequency &gt; MLBCLK(external) frequency</p> <p>(2) MediaLB Output Timing</p> <table border="1"> <thead> <tr> <th rowspan="2">Parameter</th> <th rowspan="2">Symbol</th> <th rowspan="2">Pin Name</th> <th rowspan="2">Conditions</th> <th colspan="2">Value</th> <th rowspan="2">Unit</th> <th rowspan="2">Remarks</th> </tr> <tr> <th>Min</th> <th>Max</th> </tr> </thead> <tbody> <tr> <td>MLBCLK cycle</td> <td>t<sub>mckc</sub></td> <td>MLBCLK</td> <td rowspan="3">(CL = 20pF, I<sub>OL</sub>=-6mA, I<sub>OH</sub>=6mA),</td> <td>40.0</td> <td>-</td> <td>ns</td> <td>-</td> </tr> <tr> <td>MLBSIG, MLBDAT output stop</td> <td>t<sub>mctdz</sub></td> <td>MLBSIG MLBDAT</td> <td>26.5</td> <td>-</td> <td>ns</td> <td>t<sub>mckc</sub> - t<sub>dout</sub></td> </tr> <tr> <td>MLBSIG, MLBDAT output delay</td> <td>t<sub>dout</sub></td> <td>MLBSIG MLBDAT</td> <td>0</td> <td>13.5</td> <td>ns</td> <td>-</td> </tr> </tbody> </table> <p>Notes: This is Target Spec.</p> <p>- CLK_HAPP1B0(internal) frequency &gt; MLBCLK(external) frequency</p>	Parameter	Symbol	Pin Name	Conditions	Value		Unit	Remarks	Min	Max	MLBCLK cycle	t <sub>mckc</sub>	MLBCLK	-	19.53	-	ns	-	MLBSIG, MLBDAT Input hold	t <sub>dthmcf</sub>	MLBSIG MLBDAT	0	-	ns	Parameter	Symbol	Pin Name	Conditions	Value		Unit	Remarks	Min	Max	MLBCLK cycle	t <sub>mckc</sub>	MLBCLK	(CL = 20pF, I <sub>OL</sub> =-6mA, I <sub>OH</sub> =6mA),	19.53	-	ns	-	MLBSIG, MLBDAT output stop	t <sub>mctdz</sub>	MLBSIG MLBDAT	10.73	-	ns	t <sub>mckc</sub> -8.8ns	MLBSIG, MLBDAT output delay	t <sub>dout</sub>	MLBSIG MLBDAT	0	8.8	ns	-	Parameter	Symbol	Pin Name	Conditions	Value		Unit	Remarks	Min	Max	MLBCLK cycle	t <sub>mckc</sub>	MLBCLK	-	40.0	-	ns	-	MLBSIG, MLBDAT Input hold	t <sub>dthmcf</sub>	MLBSIG MLBDAT	4.0	-	ns	Parameter	Symbol	Pin Name	Conditions	Value		Unit	Remarks	Min	Max	MLBCLK cycle	t <sub>mckc</sub>	MLBCLK	(CL = 20pF, I <sub>OL</sub> =-6mA, I <sub>OH</sub> =6mA),	40.0	-	ns	-	MLBSIG, MLBDAT output stop	t <sub>mctdz</sub>	MLBSIG MLBDAT	26.5	-	ns	t <sub>mckc</sub> - t <sub>dout</sub>	MLBSIG, MLBDAT output delay	t <sub>dout</sub>	MLBSIG MLBDAT	0	13.5	ns	-
Parameter	Symbol	Pin Name					Conditions	Value			Unit	Remarks																																																																																																						
			Min	Max																																																																																																														
MLBCLK cycle	t <sub>mckc</sub>	MLBCLK	-	19.53	-	ns	-																																																																																																											
MLBSIG, MLBDAT Input hold	t <sub>dthmcf</sub>	MLBSIG MLBDAT		0	-	ns																																																																																																												
Parameter	Symbol	Pin Name	Conditions	Value		Unit	Remarks																																																																																																											
				Min	Max																																																																																																													
MLBCLK cycle	t <sub>mckc</sub>	MLBCLK	(CL = 20pF, I <sub>OL</sub> =-6mA, I <sub>OH</sub> =6mA),	19.53	-	ns	-																																																																																																											
MLBSIG, MLBDAT output stop	t <sub>mctdz</sub>	MLBSIG MLBDAT		10.73	-	ns	t <sub>mckc</sub> -8.8ns																																																																																																											
MLBSIG, MLBDAT output delay	t <sub>dout</sub>	MLBSIG MLBDAT		0	8.8	ns	-																																																																																																											
Parameter	Symbol	Pin Name	Conditions	Value		Unit	Remarks																																																																																																											
				Min	Max																																																																																																													
MLBCLK cycle	t <sub>mckc</sub>	MLBCLK	-	40.0	-	ns	-																																																																																																											
MLBSIG, MLBDAT Input hold	t <sub>dthmcf</sub>	MLBSIG MLBDAT		4.0	-	ns																																																																																																												
Parameter	Symbol	Pin Name	Conditions	Value		Unit	Remarks																																																																																																											
				Min	Max																																																																																																													
MLBCLK cycle	t <sub>mckc</sub>	MLBCLK	(CL = 20pF, I <sub>OL</sub> =-6mA, I <sub>OH</sub> =6mA),	40.0	-	ns	-																																																																																																											
MLBSIG, MLBDAT output stop	t <sub>mctdz</sub>	MLBSIG MLBDAT		26.5	-	ns	t <sub>mckc</sub> - t <sub>dout</sub>																																																																																																											
MLBSIG, MLBDAT output delay	t <sub>dout</sub>	MLBSIG MLBDAT		0	13.5	ns	-																																																																																																											
246	11.Ordering Information	<p>Revised part number as below: Error)</p> <p>S6J331EKCB***** S6J331EKBB***** S6J331EKAB***** S6J331EJCB***** S6J332EJCB***** S6J331EJAB***** S6J332EJAB***** S6J332EHSB*****</p> <p>Correct)</p> <p>S6J331EKCC***** S6J331EKBC***** S6J331EKAC***** S6J331EJCC***** S6J332EJCC***** S6J331EJAC***** S6J332EJAC***** S6J332EHSC*****</p>																																																																																																																

Page	Section	Change Results		
Rev. *B				
13	3.Product Description 3.2.Product description	<p>Revised the below: Error) (None) 12bit resolution, 2 unit 48 channels of analog input for TEQFP208 48 channels of analog input for TEQFP176 35 channel of analog input for TEQFP144 24 channels of them are shared with the SMC for TEQFP208/176/144 External trigger and timer trigger are available. The description of the A/D converter function should be referred in the S6J3300 hardware manual. Though the chapter of I/O port in Traveo™ Platform hardware manual describes another A/D converter function, do not refer it.</p> <p>Correct) 12bit resolution, 2 unit(Unit0 is possible to select channels 4-31. Unit1 is possible to select channels 32-63.) 48 channels of analog input for TEQFP208 48 channels of analog input for TEQFP176 35 channel of analog input for TEQFP144 24 channels of them are shared with the SMC for TEQFP208/176/144 External trigger and timer trigger are available. The description of the A/D converter function should be referred in the S6J3300 hardware manual. Though the chapter of I/O port in Traveo™ Platform hardware manual describes another A/D converter function, do not refer it. A/D Channel Control Register (ADC12Bn_CHCTRL0)[bit5:0] ANIN[5:0] : Analog Input Selection bits. This register setting is possible of channel 0-31 (the register value is 00_0000 to 01_1111).</p>		
15	3.Product Description 3.2.Product description	<p>Revised as below: Correct)</p> <table border="1" data-bbox="423 1045 1458 1287"> <tr> <td>Power Supply Control (PSC)</td> <td> <p>PSC (PSC_1) output is used for external 1.2V power supply module control and automatically switched with the following condition.</p> <p>"High": Request to supply VCC12</p> <ul style="list-style-type: none"> <li>- "Power ON Reset" is released</li> <li>- CPU wakes up from PSS shutdown mode</li> </ul> <p>"Low": Request to stop supplying VCC12</p> <ul style="list-style-type: none"> <li>- CPU transfers from RUN mode to PSS shutdown mode.</li> </ul> <p>For timing chart of output signals include PSC in detail, see the "S6J3300 hardware manual" and chapter "State Transition"</p> </td> </tr> </table>	Power Supply Control (PSC)	<p>PSC (PSC_1) output is used for external 1.2V power supply module control and automatically switched with the following condition.</p> <p>"High": Request to supply VCC12</p> <ul style="list-style-type: none"> <li>- "Power ON Reset" is released</li> <li>- CPU wakes up from PSS shutdown mode</li> </ul> <p>"Low": Request to stop supplying VCC12</p> <ul style="list-style-type: none"> <li>- CPU transfers from RUN mode to PSS shutdown mode.</li> </ul> <p>For timing chart of output signals include PSC in detail, see the "S6J3300 hardware manual" and chapter "State Transition"</p>
Power Supply Control (PSC)	<p>PSC (PSC_1) output is used for external 1.2V power supply module control and automatically switched with the following condition.</p> <p>"High": Request to supply VCC12</p> <ul style="list-style-type: none"> <li>- "Power ON Reset" is released</li> <li>- CPU wakes up from PSS shutdown mode</li> </ul> <p>"Low": Request to stop supplying VCC12</p> <ul style="list-style-type: none"> <li>- CPU transfers from RUN mode to PSS shutdown mode.</li> </ul> <p>For timing chart of output signals include PSC in detail, see the "S6J3300 hardware manual" and chapter "State Transition"</p>			
22 23	4.Package and Pin Assignment 4.2.Package Dimensions	<p>Revised as below: 4.2.3.TEQFP144 Error) Figure 4 6: TEQFP144 Figure 4 7: TEQFP144 The package dimension of TEQFP144 (0.4mm Pitch) is the provisional version.</p> <p>Correct) Figure 4 6: TEQFP144 (0.5mm Pitch) Figure 4 7: TEQFP144 (0.4mm Pitch) The package dimension of TEQFP144 (0.4mm Pitch) is the formal version.</p>		
31 32	6.Port Description 6.1 Port Description list	<p>Revised the below: Error) ADC Analog [4 to18, 21, 24 to 26, 28 to 32, 39 to 47, 49 to 63] input pin</p> <p>Correct) ADC Unit0 [ch.4 to ch.18, ch.21, ch.24 to ch.26, ch.28 to ch.31] input pin ADC Unit1 [ch.32, ch.39 to ch.47, ch.49 to ch.63] input pin</p>		



Page	Section	Change Results
155	8.Precautions and Handling Devices 8.1.1.Precautions for Product Design	<p>Revised the below: Error) (1) Preventing Over-Voltage and Over-Current Conditions Exposure to voltage or current levels in excess of maximum ratings at any pin is likely to cause deterioration within the device, and in extreme cases leads to permanent damage of the device. Try to prevent such overvoltage or over-current conditions at the design stage.</p> <p>Correct) (1) Preventing Over-Voltage and Over-Current Conditions Exposure to voltage or current levels in excess of maximum ratings at any pin is likely to cause deterioration within the device and in extreme cases leads to permanent damage of the device. Try to prevent such overvoltage or over-current conditions at the design stage.</p>
159	8.Precautions and Handling Devices 8.2.Handling Devices	<p>Revised as below: Correct) <b>Method to Switch Off VCC12 during Power-Off Sequence</b> During power-off sequence, it is necessary to switch off VCC12 by driving PSC1 pin low by entering PSS mode (power domain 2 off). If VCC12 needs to be switched off by other means, RSTX needs to be asserted before switching off VCC12 to inactivate the operation of VCC12 supplied domain below the operation assurance range.</p>
164	9.Electric Characteristics 9.1.2 Recommended operating condition	<p>Revised as below: Error) The detection/release threshold values of following LVD channels are potentially below supply range defined in 9.1.2 Recommended operating condition (refer to "9.1.4.11 Low Voltage Detection (External Voltage)" and "9.1.4.12 Low Voltage Detection (Internal Voltage)" for detection/release threshold values for these LVD channels): LVDL0 LVDL1 LVDL2 LVDH0 LVDH1 LVDH2</p> <p>Correct) The detection/release threshold values of following LVD channels are potentially below supply range defined in 9.1.2 Recommended operating condition (refer to "9.1.4.11 Low Voltage Detection (External Voltage)" and "9.1.4.12 Low Voltage Detection (Internal Voltage)" for detection/release threshold values for these LVD channels): LVDL0 LVDL1 LVDL2 LVDH0 LVDH1 LVDH2 Detection voltage of the external low voltage detection reset (initial) is <math>2.6V \pm 3.5\%^{2 \ 3}</math> or <math>4.0V \pm 3.5\%^{1}</math>. This detection voltage level setting is below the minimum operation assurance voltage (<math>2.7V^{2 \ 3}</math> or <math>4.0V^{1}</math>). Between this detection voltage and the minimum operation assurance voltage, MCU functions are not guaranteed except for the low voltage detector. Note that although the detection level is below the minimum operation guarantee voltage, the LVD reset factor flag is set as the voltage drops below the detection level.</p>

Page	Section	Change Results																																																					
174	9.Electric Characteristics 9.1.4.1.Source clock timing	<p>Revised as below: Error)</p> <p>Notes: - The maximum/minimum values have been standardized with the main clock and PLL clock in use. - Jitter of source oscillator must be smaller than 300ppm.</p> <p>Correct)</p> <p>Notes: - The maximum/minimum values have been standardized with the main clock and PLL clock in use. - Jitter of source oscillator must be smaller than 300ppm. - Enough evaluation and adjustment are recommended using oscillator on your system board.</p>																																																					
177	9.Electric Characteristics 9.1.4.3.Internal clock timing	<p>Revised as below: Error)</p> <p>- Note that Ta=125 condition is not supported in this product type.</p> <p>When using SSCG_PLL output for these internal clock, the MAX value of frequency has the following restrictions. - On the presumption that the modulation mode of SSCG_PLL is used with down spread, the MAX value of the frequency is standardized. - This means that MAX value of frequency is the maximum value when SSCG_PLL was modulated.</p> <p>Correct)</p> <p>- Note that Ta=125 condition is not supported in this product type.</p> <p>When using SSCG_PLL output for these internal clock, the MAX value of frequency has the following restrictions. - On the presumption that the modulation mode of SSCG_PLL is used with down spread, the MAX value of the frequency is standardized. - This means that MAX value of frequency is the maximum value when SSCG_PLL was modulated. - "Unused" means a clock source which doesn't have any supply destinations. Configure it as disable with performing at the lower clock frequency than the described maximum.</p>																																																					
179	9.Electric Characteristics 9.1.4.3.internal clock timing	<p>Added Oscillation clock frequency as below: Correct)</p> <table border="1"> <thead> <tr> <th colspan="2" rowspan="3"></th> <th colspan="8">Internal Operation Clock Frequency</th> </tr> <tr> <th rowspan="2">Main Clock</th> <th colspan="7">PLL Clock</th> </tr> <tr> <th>Multiplied by 1</th> <th>Multiplied by 2</th> <th>...</th> <th>Multiplied by 15</th> <th>Multiplied by 30</th> <th>Multiplied by 40</th> <th>Multiplied by 60</th> </tr> </thead> <tbody> <tr> <td rowspan="3">Oscillation clock frequency [MHz]</td> <td>4</td> <td>2</td> <td>4</td> <td>8</td> <td>...</td> <td>60</td> <td>120</td> <td>160</td> <td>240</td> </tr> <tr> <td>8</td> <td>4</td> <td>8</td> <td>16</td> <td>...</td> <td>120</td> <td>240</td> <td></td> <td></td> </tr> <tr> <td>16</td> <td>8</td> <td>16</td> <td>32</td> <td>...</td> <td>240</td> <td></td> <td></td> <td></td> </tr> </tbody> </table>			Internal Operation Clock Frequency								Main Clock	PLL Clock							Multiplied by 1	Multiplied by 2	...	Multiplied by 15	Multiplied by 30	Multiplied by 40	Multiplied by 60	Oscillation clock frequency [MHz]	4	2	4	8	...	60	120	160	240	8	4	8	16	...	120	240			16	8	16	32	...	240			
		Internal Operation Clock Frequency																																																					
		Main Clock			PLL Clock																																																		
			Multiplied by 1	Multiplied by 2	...	Multiplied by 15	Multiplied by 30	Multiplied by 40	Multiplied by 60																																														
Oscillation clock frequency [MHz]	4	2	4	8	...	60	120	160	240																																														
	8	4	8	16	...	120	240																																																
	16	8	16	32	...	240																																																	

Page	Section	Change Results																																																				
208	9.Electric Characteristics 9.1.4.6 Multi-Function Serial	<p>Revised as below: Error) I<sup>2</sup>C timing (SMR:MD2-0=0b100) (T<sub>A</sub>: Recommended operating conditions, V<sub>CC5</sub>=V<sub>CC53</sub>=5.0 V ±10%, V<sub>CC12</sub>=1.15V ±0.06V, V<sub>SS</sub>=0.0 V)</p> <table border="1"> <thead> <tr> <th rowspan="2">Parameter</th> <th rowspan="2">Symbol</th> <th rowspan="2">Pin Name</th> <th rowspan="2">Conditions</th> <th colspan="2">Standard Mode</th> <th colspan="2">High-Speed Mode</th> <th rowspan="2">Unit</th> <th rowspan="2">Remarks</th> </tr> <tr> <th>Min</th> <th>Max</th> <th>Min</th> <th>Max</th> </tr> </thead> <tbody> <tr> <td>SCL clock frequency</td> <td>f<sub>SCL</sub></td> <td>SCL0, SCL1, SCL4, SCL8 to SCL12, SCL16 to SCL17</td> <td>C<sub>L</sub>=50pF, R=(V<sub>p</sub>/I<sub>OL</sub>)<sup>*1</sup></td> <td>0</td> <td>100</td> <td>0</td> <td>400</td> <td>kHz</td> <td></td> </tr> </tbody> </table> <p>Correct) I<sup>2</sup>C timing (SMR:MD2-0=0b100) (T<sub>A</sub>: Recommended operating conditions, V<sub>CC5</sub>=V<sub>CC53</sub>=5.0 V ±10%, V<sub>CC12</sub>=1.15V ±0.06V, V<sub>SS</sub>=0.0 V)</p> <table border="1"> <thead> <tr> <th rowspan="2">Parameter</th> <th rowspan="2">Symbol</th> <th rowspan="2">Pin Name</th> <th rowspan="2">Conditions</th> <th colspan="2">Standard Mode</th> <th colspan="2">Fast Mode</th> <th rowspan="2">Unit</th> <th rowspan="2">Remarks</th> </tr> <tr> <th>Min</th> <th>Max</th> <th>Min</th> <th>Max</th> </tr> </thead> <tbody> <tr> <td>SCL clock frequency</td> <td>f<sub>SCL</sub></td> <td>SCL0, SCL1, SCL4, SCL8 to SCL12, SCL16 to SCL17</td> <td>C<sub>L</sub>=50pF, R=(V<sub>p</sub>/I<sub>OL</sub>)<sup>*1</sup></td> <td>0</td> <td>100</td> <td>0</td> <td>400</td> <td>kHz</td> <td></td> </tr> </tbody> </table> <p>Error) *3: A high-speed mode I<sup>2</sup>C bus device can be used on a standard mode I<sup>2</sup>C bus system as long as the device satisfies the requirement of "t<sub>SUDAT</sub> ≥ 250 ns".</p> <p>Correct) *3: A fast mode I<sup>2</sup>C bus device can be used on a standard mode I<sup>2</sup>C bus system as long as the device satisfies the requirement of "t<sub>SUDAT</sub> ≥ 250 ns".</p>	Parameter	Symbol	Pin Name	Conditions	Standard Mode		High-Speed Mode		Unit	Remarks	Min	Max	Min	Max	SCL clock frequency	f <sub>SCL</sub>	SCL0, SCL1, SCL4, SCL8 to SCL12, SCL16 to SCL17	C <sub>L</sub> =50pF, R=(V <sub>p</sub> /I <sub>OL</sub> ) <sup>*1</sup>	0	100	0	400	kHz		Parameter	Symbol	Pin Name	Conditions	Standard Mode		Fast Mode		Unit	Remarks	Min	Max	Min	Max	SCL clock frequency	f <sub>SCL</sub>	SCL0, SCL1, SCL4, SCL8 to SCL12, SCL16 to SCL17	C <sub>L</sub> =50pF, R=(V <sub>p</sub> /I <sub>OL</sub> ) <sup>*1</sup>	0	100	0	400	kHz					
Parameter	Symbol	Pin Name					Conditions	Standard Mode		High-Speed Mode			Unit	Remarks																																								
			Min	Max	Min	Max																																																
SCL clock frequency	f <sub>SCL</sub>	SCL0, SCL1, SCL4, SCL8 to SCL12, SCL16 to SCL17	C <sub>L</sub> =50pF, R=(V <sub>p</sub> /I <sub>OL</sub> ) <sup>*1</sup>	0	100	0	400	kHz																																														
Parameter	Symbol	Pin Name	Conditions	Standard Mode		Fast Mode		Unit	Remarks																																													
				Min	Max	Min	Max																																															
SCL clock frequency	f <sub>SCL</sub>	SCL0, SCL1, SCL4, SCL8 to SCL12, SCL16 to SCL17	C <sub>L</sub> =50pF, R=(V <sub>p</sub> /I <sub>OL</sub> ) <sup>*1</sup>	0	100	0	400	kHz																																														
216	9.Electric Characteristics 9.1.4.11. Low Voltage Detection (External Voltage)	<p>Added *5 and *5 sentences as below: Error)</p> <table border="1"> <thead> <tr> <th rowspan="2">Parameter</th> <th rowspan="2">Symbol</th> <th rowspan="2">Pin Name</th> <th rowspan="2">Conditions</th> <th colspan="3">Value</th> <th rowspan="2">Unit</th> <th rowspan="2">Remarks</th> </tr> <tr> <th>Min</th> <th>Typ</th> <th>Max</th> </tr> </thead> <tbody> <tr> <td rowspan="2">Detection voltage (after trimming)</td> <td rowspan="2">V<sub>DLAT</sub></td> <td>VCC5</td> <td>*1</td> <td>3.86<sup>*3</sup></td> <td>4.0<sup>*3</sup></td> <td>4.14<sup>*3</sup></td> <td rowspan="2">V</td> <td rowspan="2">When power-supply voltage falls and detection level is set initially Typ±3.5%</td> </tr> <tr> <td>VCC3</td> <td>*1</td> <td>2.51<sup>*4</sup></td> <td>2.6<sup>*4</sup></td> <td>2.69<sup>*4</sup></td> </tr> </tbody> </table> <p>Correct)</p> <table border="1"> <thead> <tr> <th rowspan="2">Parameter</th> <th rowspan="2">Symbol</th> <th rowspan="2">Pin Name</th> <th rowspan="2">Conditions</th> <th colspan="3">Value</th> <th rowspan="2">Unit</th> <th rowspan="2">Remarks</th> </tr> <tr> <th>Min</th> <th>Typ</th> <th>Max</th> </tr> </thead> <tbody> <tr> <td rowspan="2">Detection voltage (after trimming)</td> <td rowspan="2">V<sub>DLAT</sub></td> <td>VCC5</td> <td>*1</td> <td>3.86<sup>*3</sup></td> <td>4.0<sup>*3</sup></td> <td>4.14<sup>*3</sup></td> <td rowspan="2">V</td> <td rowspan="2">When power-supply voltage falls and detection level is set initially Typ±3.5%<sup>*5</sup></td> </tr> <tr> <td>VCC3</td> <td>*1</td> <td>2.51</td> <td>2.6</td> <td>2.69</td> </tr> </tbody> </table> <p>*5: This detection voltage level setting is below the minimum operation assurance voltage (2.7V<sup>*4</sup> or 4.0V<sup>*3</sup>). Between this detection voltage and the minimum operation assurance voltage, MCU functions are not guaranteed except for the low voltage detector. Note that although the detection level is below the minimum operation guarantee voltage, the LVD reset factor flag is set as the voltage drops below the detection level.</p>	Parameter	Symbol	Pin Name	Conditions	Value			Unit	Remarks	Min	Typ	Max	Detection voltage (after trimming)	V <sub>DLAT</sub>	VCC5	*1	3.86 <sup>*3</sup>	4.0 <sup>*3</sup>	4.14 <sup>*3</sup>	V	When power-supply voltage falls and detection level is set initially Typ±3.5%	VCC3	*1	2.51 <sup>*4</sup>	2.6 <sup>*4</sup>	2.69 <sup>*4</sup>	Parameter	Symbol	Pin Name	Conditions	Value			Unit	Remarks	Min	Typ	Max	Detection voltage (after trimming)	V <sub>DLAT</sub>	VCC5	*1	3.86 <sup>*3</sup>	4.0 <sup>*3</sup>	4.14 <sup>*3</sup>	V	When power-supply voltage falls and detection level is set initially Typ±3.5% <sup>*5</sup>	VCC3	*1	2.51	2.6	2.69
Parameter	Symbol	Pin Name					Conditions	Value				Unit	Remarks																																									
			Min	Typ	Max																																																	
Detection voltage (after trimming)	V <sub>DLAT</sub>	VCC5	*1	3.86 <sup>*3</sup>	4.0 <sup>*3</sup>	4.14 <sup>*3</sup>	V	When power-supply voltage falls and detection level is set initially Typ±3.5%																																														
		VCC3	*1	2.51 <sup>*4</sup>	2.6 <sup>*4</sup>	2.69 <sup>*4</sup>																																																
Parameter	Symbol	Pin Name	Conditions	Value			Unit	Remarks																																														
				Min	Typ	Max																																																
Detection voltage (after trimming)	V <sub>DLAT</sub>	VCC5	*1	3.86 <sup>*3</sup>	4.0 <sup>*3</sup>	4.14 <sup>*3</sup>	V	When power-supply voltage falls and detection level is set initially Typ±3.5% <sup>*5</sup>																																														
		VCC3	*1	2.51	2.6	2.69																																																

Page	Section	Change Results																																										
217	9.Electric Characteristics 9.1.4.11.Low Voltage Detection (External Voltage)	<p>Added *2 and *2 sentences as below:</p> <p>Error)</p> <table border="1"> <thead> <tr> <th rowspan="2">Parameter</th> <th rowspan="2">Symbol</th> <th rowspan="2">Pin Name</th> <th rowspan="2">Conditions</th> <th colspan="3">Value</th> <th rowspan="2">Unit</th> <th rowspan="2">Remarks</th> </tr> <tr> <th>Min</th> <th>Typ</th> <th>Max</th> </tr> </thead> <tbody> <tr> <td>Detection voltage (after trimming)</td> <td>V<sub>RDLAT</sub></td> <td>VCC12</td> <td>*1</td> <td>0.7841</td> <td>0.8125</td> <td>0.8410</td> <td>V</td> <td>When power-supply voltage falls Typ±3.5%</td> </tr> </tbody> </table> <p>Correct)</p> <table border="1"> <thead> <tr> <th rowspan="2">Parameter</th> <th rowspan="2">Symbol</th> <th rowspan="2">Pin Name</th> <th rowspan="2">Conditions</th> <th colspan="3">Value</th> <th rowspan="2">Unit</th> <th rowspan="2">Remarks</th> </tr> <tr> <th>Min</th> <th>Typ</th> <th>Max</th> </tr> </thead> <tbody> <tr> <td>Detection voltage (after trimming)</td> <td>V<sub>RDLAT</sub></td> <td>VCC12</td> <td>*1</td> <td>0.7841</td> <td>0.8125</td> <td>0.8410</td> <td>V</td> <td>When power-supply voltage falls Typ±3.5% *2</td> </tr> </tbody> </table> <p>*2: This detection voltage level setting is below the minimum operation assurance voltage . Between this detection voltage and the minimum operation assurance voltage, MCU functions are not guaranteed except for the low voltage detector. Note that although the detection level is below the minimum operation guarantee voltage, the LVD reset factor flag is set as the voltage drops below the detection level.</p>	Parameter	Symbol	Pin Name	Conditions	Value			Unit	Remarks	Min	Typ	Max	Detection voltage (after trimming)	V <sub>RDLAT</sub>	VCC12	*1	0.7841	0.8125	0.8410	V	When power-supply voltage falls Typ±3.5%	Parameter	Symbol	Pin Name	Conditions	Value			Unit	Remarks	Min	Typ	Max	Detection voltage (after trimming)	V <sub>RDLAT</sub>	VCC12	*1	0.7841	0.8125	0.8410	V	When power-supply voltage falls Typ±3.5% *2
Parameter	Symbol	Pin Name					Conditions	Value				Unit	Remarks																															
			Min	Typ	Max																																							
Detection voltage (after trimming)	V <sub>RDLAT</sub>	VCC12	*1	0.7841	0.8125	0.8410	V	When power-supply voltage falls Typ±3.5%																																				
Parameter	Symbol	Pin Name	Conditions	Value			Unit	Remarks																																				
				Min	Typ	Max																																						
Detection voltage (after trimming)	V <sub>RDLAT</sub>	VCC12	*1	0.7841	0.8125	0.8410	V	When power-supply voltage falls Typ±3.5% *2																																				
218	9.Electric Characteristics 9.1.4.12.Low Voltage Detection (Internal Voltage)	<p>Added *2 and *2 sentences as below:</p> <p>Error)</p> <table border="1"> <thead> <tr> <th rowspan="2">Parameter</th> <th rowspan="2">Symbol</th> <th rowspan="2">Pin Name</th> <th rowspan="2">Conditions</th> <th colspan="3">Value</th> <th rowspan="2">Unit</th> <th rowspan="2">Remarks</th> </tr> <tr> <th>Min</th> <th>Typ</th> <th>Max</th> </tr> </thead> <tbody> <tr> <td>Detection voltage (after trimming)</td> <td>V<sub>RDLAT</sub></td> <td>-</td> <td>*1</td> <td>0.844</td> <td>0.875</td> <td>0.906</td> <td>V</td> <td>When power-supply voltage falls Typ±3.5%</td> </tr> </tbody> </table> <p>Correct)</p> <table border="1"> <thead> <tr> <th rowspan="2">Parameter</th> <th rowspan="2">Symbol</th> <th rowspan="2">Pin Name</th> <th rowspan="2">Conditions</th> <th colspan="3">Value</th> <th rowspan="2">Unit</th> <th rowspan="2">Remarks</th> </tr> <tr> <th>Min</th> <th>Typ</th> <th>Max</th> </tr> </thead> <tbody> <tr> <td>Detection voltage (after trimming)</td> <td>V<sub>RDLAT</sub></td> <td>-</td> <td>*1</td> <td>0.844</td> <td>0.875</td> <td>0.906</td> <td>V</td> <td>When power-supply voltage falls Typ±3.5% *2</td> </tr> </tbody> </table> <p>*2: This detection voltage level setting is below the minimum operation assurance voltage . Between this detection voltage and the minimum operation assurance voltage, MCU functions are not guaranteed except for the low voltage detector. Note that although the detection level is below the minimum operation guarantee voltage, the LVD reset factor flag is set as the voltage drops below the detection level.</p>	Parameter	Symbol	Pin Name	Conditions	Value			Unit	Remarks	Min	Typ	Max	Detection voltage (after trimming)	V <sub>RDLAT</sub>	-	*1	0.844	0.875	0.906	V	When power-supply voltage falls Typ±3.5%	Parameter	Symbol	Pin Name	Conditions	Value			Unit	Remarks	Min	Typ	Max	Detection voltage (after trimming)	V <sub>RDLAT</sub>	-	*1	0.844	0.875	0.906	V	When power-supply voltage falls Typ±3.5% *2
Parameter	Symbol	Pin Name					Conditions	Value				Unit	Remarks																															
			Min	Typ	Max																																							
Detection voltage (after trimming)	V <sub>RDLAT</sub>	-	*1	0.844	0.875	0.906	V	When power-supply voltage falls Typ±3.5%																																				
Parameter	Symbol	Pin Name	Conditions	Value			Unit	Remarks																																				
				Min	Typ	Max																																						
Detection voltage (after trimming)	V <sub>RDLAT</sub>	-	*1	0.844	0.875	0.906	V	When power-supply voltage falls Typ±3.5% *2																																				

Page	Section	Change Results																																																																																															
238	9.Electric	Added AC specification of LCD bus I/F as below.																																																																																															
239	Characteristics																																																																																																
240	9.1.4.21	Correct)																																																																																															
241	LCDCbus I/F	<p><b>9.1.4.21 LCDCbus I/F</b></p> <p><b>(1) Intel-8080</b>            (TA: Recommended operating conditions, Vcc3=3.3 V ±0.3V, VSS=DVSS=AVSS=0.0 V)</p> <table border="1"> <thead> <tr> <th rowspan="2">Parameter</th> <th rowspan="2">Symbol</th> <th rowspan="2">Pin Name</th> <th rowspan="2">Conditions</th> <th colspan="2">Value</th> <th rowspan="2">Unit</th> <th rowspan="2">Remarks</th> </tr> <tr> <th>Min</th> <th>Max</th> </tr> </thead> <tbody> <tr> <td>Address hold time</td> <td>tAH</td> <td>D/C#</td> <td rowspan="13">(CL = 20pF, IOL=-5mA, IOH=5mA),</td> <td>20</td> <td>-</td> <td>ns</td> <td></td> </tr> <tr> <td>Address setup time</td> <td>tAW</td> <td>D/C#</td> <td>20</td> <td>-</td> <td>ns</td> <td></td> </tr> <tr> <td>Write cycle time</td> <td>tCYCW</td> <td>CS#, WR#</td> <td>100</td> <td>-</td> <td>ns</td> <td></td> </tr> <tr> <td>Write, Enable pulse H width</td> <td>tCCHW</td> <td>CS#, WR#</td> <td>35</td> <td>-</td> <td>ns</td> <td></td> </tr> <tr> <td>Write, Enable pulse L width</td> <td>tCCLW</td> <td>CS#, WR#</td> <td>35</td> <td>-</td> <td>ns</td> <td></td> </tr> <tr> <td>Write data set time</td> <td>tDS</td> <td>DB</td> <td>20</td> <td>-</td> <td>ns</td> <td></td> </tr> <tr> <td>Write data hold time</td> <td>tDH</td> <td>DB</td> <td>20</td> <td>-</td> <td>ns</td> <td></td> </tr> <tr> <td>Read cycle time</td> <td>tCYCR</td> <td>CS#, RD#</td> <td>255</td> <td>-</td> <td>ns</td> <td></td> </tr> <tr> <td>Read pulse H width</td> <td>tCCHR</td> <td>CS#, RD#</td> <td>90</td> <td>-</td> <td>ns</td> <td></td> </tr> <tr> <td>Read pulse L width</td> <td>tCCLR</td> <td>CS#, RD#</td> <td>150</td> <td>-</td> <td>ns</td> <td></td> </tr> <tr> <td>Read data access time</td> <td>tACC</td> <td>DB</td> <td>-</td> <td>145</td> <td>ns</td> <td></td> </tr> <tr> <td>Read data disable time</td> <td>tOH</td> <td>DB</td> <td>15</td> <td>-</td> <td>ns</td> <td></td> </tr> </tbody> </table>	Parameter	Symbol	Pin Name	Conditions	Value		Unit	Remarks	Min	Max	Address hold time	tAH	D/C#	(CL = 20pF, IOL=-5mA, IOH=5mA),	20	-	ns		Address setup time	tAW	D/C#	20	-	ns		Write cycle time	tCYCW	CS#, WR#	100	-	ns		Write, Enable pulse H width	tCCHW	CS#, WR#	35	-	ns		Write, Enable pulse L width	tCCLW	CS#, WR#	35	-	ns		Write data set time	tDS	DB	20	-	ns		Write data hold time	tDH	DB	20	-	ns		Read cycle time	tCYCR	CS#, RD#	255	-	ns		Read pulse H width	tCCHR	CS#, RD#	90	-	ns		Read pulse L width	tCCLR	CS#, RD#	150	-	ns		Read data access time	tACC	DB	-	145	ns		Read data disable time	tOH	DB	15	-	ns	
Parameter	Symbol	Pin Name					Conditions	Value			Unit	Remarks																																																																																					
			Min	Max																																																																																													
Address hold time	tAH	D/C#	(CL = 20pF, IOL=-5mA, IOH=5mA),	20	-	ns																																																																																											
Address setup time	tAW	D/C#		20	-	ns																																																																																											
Write cycle time	tCYCW	CS#, WR#		100	-	ns																																																																																											
Write, Enable pulse H width	tCCHW	CS#, WR#		35	-	ns																																																																																											
Write, Enable pulse L width	tCCLW	CS#, WR#		35	-	ns																																																																																											
Write data set time	tDS	DB		20	-	ns																																																																																											
Write data hold time	tDH	DB		20	-	ns																																																																																											
Read cycle time	tCYCR	CS#, RD#		255	-	ns																																																																																											
Read pulse H width	tCCHR	CS#, RD#		90	-	ns																																																																																											
Read pulse L width	tCCLR	CS#, RD#		150	-	ns																																																																																											
Read data access time	tACC	DB		-	145	ns																																																																																											
Read data disable time	tOH	DB		15	-	ns																																																																																											

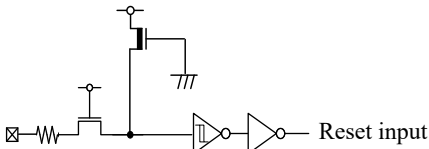
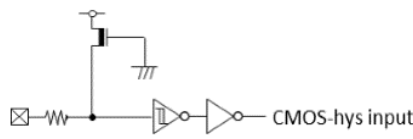
Page	Section	Change Results																																																																																																																
		<p><b>(2) Motorola-6800</b></p> <p>(TA: Recommended operating conditions, Vcc3=3.3 V ±0.3V, VSS=DVSS=AVSS=0.0 V)</p>																																																																																																																
		<table border="1"> <thead> <tr> <th rowspan="2">Parameter</th> <th rowspan="2">Symbol</th> <th rowspan="2">Pin Name</th> <th rowspan="2">Conditions</th> <th colspan="2">Value</th> <th rowspan="2">Unit</th> <th rowspan="2">Remarks</th> </tr> <tr> <th>Min</th> <th>Max</th> </tr> </thead> <tbody> <tr> <td>Address hold time</td> <td>tAH</td> <td>D/C#, R/W#</td> <td rowspan="4">(CL = 20pF, IOL=-5mA, IOH=5mA)</td> <td>20</td> <td>-</td> <td>ns</td> <td></td> </tr> <tr> <td>Address setup time</td> <td>tAW</td> <td>D/C#, R/W#</td> <td>20</td> <td>-</td> <td>ns</td> <td></td> </tr> <tr> <td>Write cycle time</td> <td>tCYCW</td> <td>CS#, E</td> <td>100</td> <td>-</td> <td>ns</td> <td></td> </tr> <tr> <td>Write, Enable pulse H width</td> <td>tEH</td> <td>CS#, E</td> <td>35</td> <td>-</td> <td>ns</td> <td></td> </tr> <tr> <td>Write, Enable pulse H width</td> <td>tEH</td> <td>CS#, E</td> <td>35</td> <td>-</td> <td>ns</td> <td></td> <td></td> </tr> <tr> <td>Write, Enable pulse L width</td> <td>tEL</td> <td>CS#,E</td> <td></td> <td>35</td> <td>-</td> <td>ns</td> <td></td> </tr> <tr> <td>Write data set time</td> <td>tDS</td> <td>DB</td> <td></td> <td>20</td> <td>-</td> <td>ns</td> <td></td> </tr> <tr> <td>Write data hold time</td> <td>tDH</td> <td>DB</td> <td></td> <td>20</td> <td>-</td> <td>ns</td> <td></td> </tr> <tr> <td>Read cycle time</td> <td>tCYCR</td> <td>CS#, E</td> <td></td> <td>255</td> <td>-</td> <td>ns</td> <td></td> </tr> <tr> <td>Read pulse H width</td> <td>tEH</td> <td>CS#, E</td> <td></td> <td>90</td> <td>-</td> <td>ns</td> <td></td> </tr> <tr> <td>Read pulse L width</td> <td>tEL</td> <td>CS#,E</td> <td></td> <td>150</td> <td>-</td> <td>ns</td> <td></td> </tr> <tr> <td>Read data access time</td> <td>tACC</td> <td>DB</td> <td></td> <td>-</td> <td>145</td> <td>ns</td> <td></td> </tr> <tr> <td>Read data disable time</td> <td>tOH</td> <td>DB</td> <td></td> <td>15</td> <td>-</td> <td>ns</td> <td></td> </tr> </tbody> </table>		Parameter	Symbol	Pin Name	Conditions	Value		Unit	Remarks	Min	Max	Address hold time	tAH	D/C#, R/W#	(CL = 20pF, IOL=-5mA, IOH=5mA)	20	-	ns		Address setup time	tAW	D/C#, R/W#	20	-	ns		Write cycle time	tCYCW	CS#, E	100	-	ns		Write, Enable pulse H width	tEH	CS#, E	35	-	ns		Write, Enable pulse H width	tEH	CS#, E	35	-	ns			Write, Enable pulse L width	tEL	CS#,E		35	-	ns		Write data set time	tDS	DB		20	-	ns		Write data hold time	tDH	DB		20	-	ns		Read cycle time	tCYCR	CS#, E		255	-	ns		Read pulse H width	tEH	CS#, E		90	-	ns		Read pulse L width	tEL	CS#,E		150	-	ns		Read data access time	tACC	DB		-	145	ns		Read data disable time	tOH	DB		15	-	ns	
Parameter	Symbol	Pin Name	Conditions					Value				Unit	Remarks																																																																																																					
				Min	Max																																																																																																													
Address hold time	tAH	D/C#, R/W#	(CL = 20pF, IOL=-5mA, IOH=5mA)	20	-	ns																																																																																																												
Address setup time	tAW	D/C#, R/W#		20	-	ns																																																																																																												
Write cycle time	tCYCW	CS#, E		100	-	ns																																																																																																												
Write, Enable pulse H width	tEH	CS#, E		35	-	ns																																																																																																												
Write, Enable pulse H width	tEH	CS#, E	35	-	ns																																																																																																													
Write, Enable pulse L width	tEL	CS#,E		35	-	ns																																																																																																												
Write data set time	tDS	DB		20	-	ns																																																																																																												
Write data hold time	tDH	DB		20	-	ns																																																																																																												
Read cycle time	tCYCR	CS#, E		255	-	ns																																																																																																												
Read pulse H width	tEH	CS#, E		90	-	ns																																																																																																												
Read pulse L width	tEL	CS#,E		150	-	ns																																																																																																												
Read data access time	tACC	DB		-	145	ns																																																																																																												
Read data disable time	tOH	DB		15	-	ns																																																																																																												

Page	Section	Change Results																																											
Rev. *C																																													
1	Features	Error) <input type="checkbox"/> General purpose I/O port : up to 146 Correct) <input type="checkbox"/> General purpose I/O port : up to 148																																											
4	1. Overview 1.2 Document definition	Error) <table border="1" data-bbox="409 489 1425 909"> <thead> <tr> <th>Document Type</th> <th>Definition</th> <th>Primary User</th> <th>Document Code</th> </tr> </thead> <tbody> <tr> <td>S6J3310/20/30/40 Datasheet</td> <td>The function and its characteristics are specified quantitatively.</td> <td>Investigator and hardware engineer</td> <td>002-10635</td> </tr> <tr> <td>S6J3300 hardware manual</td> <td>The function and its operation of S6J3300 series are described.</td> <td>Software engineer</td> <td>002-10185</td> </tr> <tr> <td>Traveo™ Platform hardware manual</td> <td>The function and its operation of CPU core platform are described.</td> <td>Software engineer</td> <td>002-07884</td> </tr> <tr> <td>Application note</td> <td>The reference software, sample application, the reference board design and so on are explained.</td> <td>Software and hardware engineer</td> <td>Under consideration</td> </tr> </tbody> </table> Correct) <table border="1" data-bbox="409 978 1425 1568"> <thead> <tr> <th>Document Type</th> <th>Definition</th> <th>Primary User</th> <th>Document Code</th> </tr> </thead> <tbody> <tr> <td>S6J3310/20/30/40 Datasheet</td> <td>The function and its characteristics are specified quantitatively.</td> <td>Investigator and hardware engineer</td> <td>002-10635</td> </tr> <tr> <td>S6J3300 hardware manual</td> <td>The function and its operation of S6J3300 series are described.</td> <td>Software engineer</td> <td>002-10185</td> </tr> <tr> <td>Traveo™ Platform hardware manual</td> <td>The function and its operation of CPU core platform are described.</td> <td>Software engineer</td> <td>002-07884</td> </tr> <tr> <td>Application note</td> <td>The reference software, sample application, the reference board design and so on are explained.</td> <td>Software and hardware engineer</td> <td>002-03898 002-04455 002-04446 002-09716 002-04452 002-04096 002-12061 002-02495</td> </tr> </tbody> </table>				Document Type	Definition	Primary User	Document Code	S6J3310/20/30/40 Datasheet	The function and its characteristics are specified quantitatively.	Investigator and hardware engineer	002-10635	S6J3300 hardware manual	The function and its operation of S6J3300 series are described.	Software engineer	002-10185	Traveo™ Platform hardware manual	The function and its operation of CPU core platform are described.	Software engineer	002-07884	Application note	The reference software, sample application, the reference board design and so on are explained.	Software and hardware engineer	Under consideration	Document Type	Definition	Primary User	Document Code	S6J3310/20/30/40 Datasheet	The function and its characteristics are specified quantitatively.	Investigator and hardware engineer	002-10635	S6J3300 hardware manual	The function and its operation of S6J3300 series are described.	Software engineer	002-10185	Traveo™ Platform hardware manual	The function and its operation of CPU core platform are described.	Software engineer	002-07884	Application note	The reference software, sample application, the reference board design and so on are explained.	Software and hardware engineer	002-03898 002-04455 002-04446 002-09716 002-04452 002-04096 002-12061 002-02495
Document Type	Definition	Primary User	Document Code																																										
S6J3310/20/30/40 Datasheet	The function and its characteristics are specified quantitatively.	Investigator and hardware engineer	002-10635																																										
S6J3300 hardware manual	The function and its operation of S6J3300 series are described.	Software engineer	002-10185																																										
Traveo™ Platform hardware manual	The function and its operation of CPU core platform are described.	Software engineer	002-07884																																										
Application note	The reference software, sample application, the reference board design and so on are explained.	Software and hardware engineer	Under consideration																																										
Document Type	Definition	Primary User	Document Code																																										
S6J3310/20/30/40 Datasheet	The function and its characteristics are specified quantitatively.	Investigator and hardware engineer	002-10635																																										
S6J3300 hardware manual	The function and its operation of S6J3300 series are described.	Software engineer	002-10185																																										
Traveo™ Platform hardware manual	The function and its operation of CPU core platform are described.	Software engineer	002-07884																																										
Application note	The reference software, sample application, the reference board design and so on are explained.	Software and hardware engineer	002-03898 002-04455 002-04446 002-09716 002-04452 002-04096 002-12061 002-02495																																										

Page	Section	Change Results																								
5	2.Function List	Error)																								
6	2.1 Product lineup	<table border="1"> <thead> <tr> <th>Function</th> <th>S6J3310</th> <th>S6J3320</th> <th>S6J3330</th> <th>S6J3340</th> <th>Remark</th> </tr> </thead> <tbody> <tr> <td>Sound waveform generator</td> <td colspan="4">1 unit x 5 outputs</td> <td>See 2.2.1</td> </tr> <tr> <td>I2S</td> <td colspan="4">2 ch</td> <td>One only supports an output as a function of the sound system.</td> </tr> </tbody> </table>	Function	S6J3310	S6J3320	S6J3330	S6J3340	Remark	Sound waveform generator	1 unit x 5 outputs				See 2.2.1	I2S	2 ch				One only supports an output as a function of the sound system.						
Function	S6J3310	S6J3320	S6J3330	S6J3340	Remark																					
Sound waveform generator	1 unit x 5 outputs				See 2.2.1																					
I2S	2 ch				One only supports an output as a function of the sound system.																					
		Correct)																								
		<table border="1"> <thead> <tr> <th>Function</th> <th>S6J3310</th> <th>S6J3320</th> <th>S6J3330</th> <th>S6J3340</th> <th>Remark</th> </tr> </thead> <tbody> <tr> <td>Sound waveform generator</td> <td colspan="2">1 unit x 5 outputs</td> <td colspan="2">No</td> <td>See 2.2.1</td> </tr> <tr> <td>I2S</td> <td colspan="2">2 ch</td> <td colspan="2">1ch</td> <td>One only supports an output as a function of the sound system.</td> </tr> </tbody> </table>	Function	S6J3310	S6J3320	S6J3330	S6J3340	Remark	Sound waveform generator	1 unit x 5 outputs		No		See 2.2.1	I2S	2 ch		1ch		One only supports an output as a function of the sound system.						
Function	S6J3310	S6J3320	S6J3330	S6J3340	Remark																					
Sound waveform generator	1 unit x 5 outputs		No		See 2.2.1																					
I2S	2 ch		1ch		One only supports an output as a function of the sound system.																					
5	2.Function List	Error)																								
6	2.1 Product lineup	<table border="1"> <thead> <tr> <th>Function</th> <th>S6J3310</th> <th>S6J3320</th> <th>S6J3330</th> <th>S6J3340</th> <th>Remark</th> </tr> </thead> <tbody> <tr> <td>General Purpose I/O</td> <td colspan="4">Option</td> <td>See 2.2.2</td> </tr> <tr> <td>12bit-A/D converter</td> <td colspan="4">2 unit - 48 input ports (Max)</td> <td>See 2.2.2</td> </tr> <tr> <td>LCD controller</td> <td colspan="4">4COM x 32 SEG (Max)</td> <td>See 2.2.2</td> </tr> </tbody> </table>	Function	S6J3310	S6J3320	S6J3330	S6J3340	Remark	General Purpose I/O	Option				See 2.2.2	12bit-A/D converter	2 unit - 48 input ports (Max)				See 2.2.2	LCD controller	4COM x 32 SEG (Max)				See 2.2.2
Function	S6J3310	S6J3320	S6J3330	S6J3340	Remark																					
General Purpose I/O	Option				See 2.2.2																					
12bit-A/D converter	2 unit - 48 input ports (Max)				See 2.2.2																					
LCD controller	4COM x 32 SEG (Max)				See 2.2.2																					
		Correct)																								
		<table border="1"> <thead> <tr> <th>Function</th> <th>S6J3310</th> <th>S6J3320</th> <th>S6J3330</th> <th>S6J3340</th> <th>Remark</th> </tr> </thead> <tbody> <tr> <td>General Purpose I/O</td> <td colspan="4">Option</td> <td>See 2.2.3</td> </tr> <tr> <td>12bit-A/D converter</td> <td colspan="4">2 unit - 48 input ports (Max)</td> <td>See 2.2.3</td> </tr> <tr> <td>LCD controller</td> <td colspan="4">4COM x 32 SEG (Max)</td> <td>See 2.2.3</td> </tr> </tbody> </table>	Function	S6J3310	S6J3320	S6J3330	S6J3340	Remark	General Purpose I/O	Option				See 2.2.3	12bit-A/D converter	2 unit - 48 input ports (Max)				See 2.2.3	LCD controller	4COM x 32 SEG (Max)				See 2.2.3
Function	S6J3310	S6J3320	S6J3330	S6J3340	Remark																					
General Purpose I/O	Option				See 2.2.3																					
12bit-A/D converter	2 unit - 48 input ports (Max)				See 2.2.3																					
LCD controller	4COM x 32 SEG (Max)				See 2.2.3																					



Page	Section	Change Results																																				
8	2.Function List 2.2.2 ID	<p>Error)</p> <table border="1"> <thead> <tr> <th>Function Digit</th> <th>Revision</th> <th>Chip ID</th> <th>JTAG ID</th> </tr> </thead> <tbody> <tr> <td>S,U,T,V</td> <td>C</td> <td>0x10122100</td> <td>0x1000B5CF</td> </tr> <tr> <td>A,C,E,G</td> <td>C</td> <td>0x10128100</td> <td>0x1000B5CF</td> </tr> <tr> <td>B,D,F,H</td> <td>C</td> <td>0x10120100</td> <td>0x1000B5CF</td> </tr> </tbody> </table> <p>Correct)</p> <table border="1"> <thead> <tr> <th>Function Digit</th> <th>Revision</th> <th>Chip ID</th> <th>JTAG ID</th> </tr> </thead> <tbody> <tr> <td rowspan="2">S,U,T,V</td> <td>C</td> <td>0x10122100</td> <td rowspan="6">0x1000B5CF</td> </tr> <tr> <td>D</td> <td>0x10122200</td> </tr> <tr> <td rowspan="2">A,C,E,G</td> <td>C</td> <td>0x10128100</td> </tr> <tr> <td>D</td> <td>0x10128200</td> </tr> <tr> <td rowspan="2">B,D,F,H</td> <td>C</td> <td>0x10120100</td> </tr> <tr> <td>D</td> <td>0x10120200</td> </tr> </tbody> </table>	Function Digit	Revision	Chip ID	JTAG ID	S,U,T,V	C	0x10122100	0x1000B5CF	A,C,E,G	C	0x10128100	0x1000B5CF	B,D,F,H	C	0x10120100	0x1000B5CF	Function Digit	Revision	Chip ID	JTAG ID	S,U,T,V	C	0x10122100	0x1000B5CF	D	0x10122200	A,C,E,G	C	0x10128100	D	0x10128200	B,D,F,H	C	0x10120100	D	0x10120200
Function Digit	Revision	Chip ID	JTAG ID																																			
S,U,T,V	C	0x10122100	0x1000B5CF																																			
A,C,E,G	C	0x10128100	0x1000B5CF																																			
B,D,F,H	C	0x10120100	0x1000B5CF																																			
Function Digit	Revision	Chip ID	JTAG ID																																			
S,U,T,V	C	0x10122100	0x1000B5CF																																			
	D	0x10122200																																				
A,C,E,G	C	0x10128100																																				
	D	0x10128200																																				
B,D,F,H	C	0x10120100																																				
	D	0x10120200																																				
10	3.Product Description 3.2 Product description	<p>Error)</p> <p>Power Domain (PD) The product series supports the power off control of PD1, PD2 (including PD3 and 5) and PD6.</p> <p>Correct)</p> <p>Power Domain (PD) The product series supports the power off control of PD1, PD2 (including PD3 and 5), PD4_0, PD4_1 and PD6.</p>																																				
17 18 19 20	4.Package and Pin Assignment 4.1.1 TEQFP-208 Pin Assignment	<p>Error)</p> <p>4.1.1 TEQFP-208 Pin Assignment(S6J3310) Figure 4 1: TEQFP-208</p> <p>Correct)</p> <p>4.1.1 TEQFP-208 Pin Assignment Figure 4-1: TEQFP-208 (S6J331xKyz) Figure 4-2: TEQFP-208 (S6J332xKyz) add Figure 4-3: TEQFP-208 (S6J333xKyz) add Figure 4-4: TEQFP-208 (S6J334xKyz) add</p>																																				
21 22 23 24	4. Package and Pin Assignment 4.1.2 TEQFP-176 Pin Assignment	<p>Error)</p> <p>4.1.2 TEQFP-176 Pin Assignment(S6J3310) Figure 4-2: TEQFP-176</p> <p>Correct)</p> <p>4.1.2 TEQFP-176 Pin Assignment Figure 4-5: TEQFP-176 (S6J331xJyz) Figure 4-6: TEQFP-176 (S6J332xJyz) add Figure 4-7: TEQFP-176 (S6J333xJyz) add Figure 4-8: TEQFP-176 (S6J334xJyz) add</p>																																				

Page	Section	Change Results
25 26 27 28	4.Package and Pin Assignment 4.1.3 TEQFP- 144 Pin Assignment	Error) 4.1.3 TEQFP-144 Pin Assignment(S6J3310) Figure 4-2: TEQFP-144 Correct) 4.1.3 TEQFP-144 Pin Assignment Figure 4-9: TEQFP-144 (S6J331xHyz) Figure 4-10: TEQFP-144 (S6J332xHyz) add Figure 4-11: TEQFP-144 (S6J333xHyz) add Figure 4-12: TEQFP-144 (S6J334xHyz) add
29	4.Package and Pin Assignment 4.2.1 TEQFP208	Error) - Correct) Revised PKG figure. Added PKG Code.
30	4.Package and Pin Assignment 4.2.2 TEQFP176	Error) - Correct) Revised PKG figure. Added PKG Code.
31 32	4.Package and Pin Assignment 4.2.3 TEQFP144	Error) - Correct) Revised PKG figure. Added PKG Code.
35	5.IO Circuit Type 5.1. I/O Circuit Type	Error) Type N  Reset input  Correct) Type N  CMOS-hys input

Page	Section	Change Results																																				
170	9. Electric Characteristics 9.1.1 Absolute Maximum Rating	<p>Error)</p> <table border="1"> <tr> <td>Power consumption</td> <td>P<sub>D</sub></td> <td>-</td> <td>1500</td> <td>mW</td> <td></td> </tr> <tr> <td rowspan="2">Operating temperature</td> <td rowspan="2">T<sub>A</sub></td> <td>-40</td> <td>105</td> <td>°C</td> <td>P<sub>D</sub>≤2000mW</td> </tr> <tr> <td>-40</td> <td>125</td> <td>°C</td> <td>P<sub>D</sub>≤1200mW</td> </tr> </table> <p>Correct)</p> <table border="1"> <tr> <td rowspan="2">Power consumption</td> <td rowspan="2">P<sub>D</sub></td> <td>-</td> <td>2000</td> <td>mW</td> <td>-40°C≤T<sub>A</sub>≤105°C</td> </tr> <tr> <td>-</td> <td>1100</td> <td>mW</td> <td>-40°C≤T<sub>A</sub>≤125°C</td> </tr> <tr> <td rowspan="2">Operating temperature</td> <td rowspan="2">T<sub>A</sub></td> <td>-40</td> <td>105</td> <td>°C</td> <td>P<sub>D</sub>≤2000mW</td> </tr> <tr> <td>-40</td> <td>125</td> <td>°C</td> <td>P<sub>D</sub>≤1100mW</td> </tr> </table>	Power consumption	P <sub>D</sub>	-	1500	mW		Operating temperature	T <sub>A</sub>	-40	105	°C	P <sub>D</sub> ≤2000mW	-40	125	°C	P <sub>D</sub> ≤1200mW	Power consumption	P <sub>D</sub>	-	2000	mW	-40°C≤T <sub>A</sub> ≤105°C	-	1100	mW	-40°C≤T <sub>A</sub> ≤125°C	Operating temperature	T <sub>A</sub>	-40	105	°C	P <sub>D</sub> ≤2000mW	-40	125	°C	P <sub>D</sub> ≤1100mW
Power consumption	P <sub>D</sub>	-	1500	mW																																		
Operating temperature	T <sub>A</sub>	-40	105	°C	P <sub>D</sub> ≤2000mW																																	
		-40	125	°C	P <sub>D</sub> ≤1200mW																																	
Power consumption	P <sub>D</sub>	-	2000	mW	-40°C≤T <sub>A</sub> ≤105°C																																	
		-	1100	mW	-40°C≤T <sub>A</sub> ≤125°C																																	
Operating temperature	T <sub>A</sub>	-40	105	°C	P <sub>D</sub> ≤2000mW																																	
		-40	125	°C	P <sub>D</sub> ≤1100mW																																	
172	9. Electric Characteristics 9.1.2 Recommended operating condition	<p>Error)</p> <table border="1"> <tr> <td rowspan="2">Operating temperature</td> <td>T<sub>A</sub></td> <td>-</td> <td>-40</td> <td>105</td> <td>°C</td> <td>P<sub>D</sub>≤2000mW</td> </tr> <tr> <td>T<sub>A</sub></td> <td>-</td> <td>-40</td> <td>125</td> <td>°C</td> <td>P<sub>D</sub>≤1200mW</td> </tr> </table> <p>Correct)</p> <table border="1"> <tr> <td rowspan="2">Operating temperature</td> <td>T<sub>A</sub></td> <td>-</td> <td>-40</td> <td>105</td> <td>°C</td> <td>P<sub>D</sub>≤2000mW</td> </tr> <tr> <td>T<sub>A</sub></td> <td>-</td> <td>-40</td> <td>125</td> <td>°C</td> <td>P<sub>D</sub>≤1100mW</td> </tr> </table>	Operating temperature	T <sub>A</sub>	-	-40	105	°C	P <sub>D</sub> ≤2000mW	T <sub>A</sub>	-	-40	125	°C	P <sub>D</sub> ≤1200mW	Operating temperature	T <sub>A</sub>	-	-40	105	°C	P <sub>D</sub> ≤2000mW	T <sub>A</sub>	-	-40	125	°C	P <sub>D</sub> ≤1100mW										
Operating temperature	T <sub>A</sub>	-		-40	105	°C	P <sub>D</sub> ≤2000mW																															
	T <sub>A</sub>	-	-40	125	°C	P <sub>D</sub> ≤1200mW																																
Operating temperature	T <sub>A</sub>	-	-40	105	°C	P <sub>D</sub> ≤2000mW																																
	T <sub>A</sub>	-	-40	125	°C	P <sub>D</sub> ≤1100mW																																
172	9. Electric Characteristics 9.1.2 Recommended operating condition	<p>Error)</p> <p>S6J33xxxSC, S6J33xxxUC, S6J33xxxTC, S6J33xxxVC, S6J33xxxBC, S6J33xxxDC, S6J33xxxFC, S6J33xxxHC, S6J33xxxAC, S6J33xxxCC, S6J33xxxEC, S6J33xxxGC</p> <p>Correct)</p> <p>S6J33xxxSx, S6J33xxxUx, S6J33xxxTx, S6J33xxxVx, S6J33xxxBx, S6J33xxxDx, S6J33xxxFx, S6J33xxxHx, S6J33xxxAx, S6J33xxxCx, S6J33xxxEx, S6J33xxxGx</p>																																				

Page	Section	Change Results
173	9. Electric Characteristics 9.1.2 Recommended operating condition	<p>Error)</p> <p>LVDL0</p> <p>LVDL1</p> <p>LVDL2</p> <p>LVDH0</p> <p>LVDH1</p> <p>LVDH2</p> <p>Detection voltage of the external low voltage detection reset (initial) is <math>2.6V \pm 3.5\% \times 2 \times 3</math> or <math>4.0V \pm 3.5\% \times 1</math>. This detection voltage level setting is below the minimum operation assurance voltage (<math>2.7V \times 2 \times 3</math> or <math>4.0V \times 1</math>).</p> <p>Between this detection voltage and the minimum operation assurance voltage, MCU functions are not guaranteed except for the low voltage detector.</p> <p>Note that although the detection level is below the minimum operation guarantee voltage, the LVD reset factor flag is set as the voltage drops below the detection level.</p> <p>Correct)</p> <p>LVDL0</p> <p>LVDL1</p> <p>LVDL2</p> <p>LVDH0</p> <p>LVDH1</p> <p>LVDH2</p> <p>When it is used outside recommended range (this is the range of guaranteed operation), contact your sales representative. The initial detection voltage of the external low voltage detection is <math>2.6V \pm 3.5\% \times 2 \times 3</math> (LVDH1/LVDH2) or <math>0.8V \pm 3.5\%</math> (LVDL2).</p> <p>This LVD setting and internal LVD (LVDL0/LVDL1) cannot be used to reliably generate a reset before voltage dips below minimum guaranteed MCU operation voltage, as these detection levels are below the minimum guaranteed MCU operation voltage.</p>

Page	Section	Change Results							
181	9. Electric	Error)							
182	Characteristics 9.1.3 DC characteristics	I <sub>CC</sub> T5	VCC5	Timer mode	-	370	810	μA	T <sub>A</sub> =25°C. Power only supplies to Backup RAM and system controllers. When using 4MHz crystal for main oscillator.
						-	360	780	μA
		I <sub>CC</sub> H5		Stop mode	-	100	400	μA	T <sub>A</sub> =25°C. Power only supplies to Backup RAM and system controllers.
		Correct)							
		I <sub>CC</sub> T5	VCC5	Timer mode	-	370	810	μA	T <sub>A</sub> =25°C. 4MHz crystal for main oscillator PD1=ON, PD4_0=ON, PD4_1=ON
					-	360	780	μA	T <sub>A</sub> =25°C. 4MHz crystal for main oscillator. PD1=ON, PD4_0=ON or PD4_1=ON
					-	350	750	μA	T <sub>A</sub> =25°C. 4MHz crystal for main oscillator. PD1=ON
					-	450	890	μA	T <sub>A</sub> =25°C. 8MHz crystal for main oscillator PD1=ON, PD4_0=ON, PD4_1=ON
					-	440	860	μA	T <sub>A</sub> =25°C. 8MHz crystal for main oscillator. PD1=ON, PD4_0=ON or PD4_1=ON
					-	430	830	μA	T <sub>A</sub> =25°C. 8MHz crystal for main oscillator. PD1=ON
					-	110	430	μA	T <sub>A</sub> =25°C. 32kHz crystal for sub oscillator PD1=ON, PD4_0=ON, PD4_1=ON
					-	100	400	μA	T <sub>A</sub> =25°C. 32kHz crystal for sub oscillator. PD1=ON, PD4_0=ON or PD4_1=ON
					-	90	370	μA	T <sub>A</sub> =25°C. 32kHz crystal for sub oscillator. PD1=ON
		I <sub>CC</sub> H5	VCC5	Stop mode	-	100	400	μA	T <sub>A</sub> =25°C. PD1=ON, PD4_0=ON, PD4_1=ON
					-	90	370	μA	T <sub>A</sub> =25°C. PD1=ON, PD4_0=ON or PD4_1=ON
					-	80	340	μA	T <sub>A</sub> =25°C. PD1=ON

Page	Section	Change Results																		
191	9. Electric Characteristics 9.1.4.5 Power-on Conditions	Error) <table border="1"> <tr> <td>Power off time</td> <td></td> <td>VCC5</td> <td>-</td> <td>100</td> <td>-</td> <td>-</td> <td>μs</td> <td>*2</td> </tr> </table> Correct) <table border="1"> <tr> <td>Power off time</td> <td>t<sub>OFF</sub></td> <td>VCC5</td> <td>-</td> <td>100</td> <td>-</td> <td>-</td> <td>μs</td> <td>*2</td> </tr> </table>	Power off time		VCC5	-	100	-	-	μs	*2	Power off time	t <sub>OFF</sub>	VCC5	-	100	-	-	μs	*2
Power off time		VCC5	-	100	-	-	μs	*2												
Power off time	t <sub>OFF</sub>	VCC5	-	100	-	-	μs	*2												
226 253	9. Electric Characteristics 9.1.4.11 Low Voltage Detection (External Voltage) 9.1.5 A/D converter	Error) S6J33xxxSC, S6J33xxxUC, S6J33xxxTC, S6J33xxxVC, S6J33xxxAC, S6J33xxxBC, S6J33xxxCC, S6J33xxxDC, S6J33xxxEC, S6J33xxxFC, S6J33xxxGC, S6J33xxxHC Correct) S6J33xxxSx, S6J33xxxUx, S6J33xxxTx, S6J33xxxVx, S6J33xxxAx, S6J33xxxBx, S6J33xxxCx, S6J33xxxDx, S6J33xxxGx, S6J33xxxFx, S6J33xxxGx, S6J33xxxHx																		

Page	Section	Change Results								
226	9. Electric Characteristics 9.1.4.11 Low Voltage Detection (External Voltage)	Low-voltage detection (external low-voltage detection Error)								
		Parameter	Symbol	Pin Name	Conditions	Value			Unit	Remarks
						Min	Typ	Max		
		Supply voltage range	V <sub>DP5</sub>	VCC5	-	3.5 <sup>*3</sup>	-	5.5 <sup>*3</sup>	V	
						2.7 <sup>*4</sup>	-	3.6 <sup>*4</sup>		
		Detection voltage (before trimming)	V <sub>DLBT</sub>	VCC5	*1	3.6 <sup>*3</sup>	4.0 <sup>*3</sup>	4.4 <sup>*3</sup>	V	When power-supply voltage falls and detection level is set initially
				VCC3	*1	2.3	2.6	2.9	V	
		Detection voltage (after trimming)	V <sub>DLAT</sub>	VCC5	*1	3.86 <sup>*3</sup>	4.0 <sup>*3</sup>	4.14 <sup>*3</sup>	V	When power-supply voltage falls and detection level is set initially
				VCC3	*1	2.51 <sup>*4</sup>	2.6 <sup>*4</sup>	2.69 <sup>*4</sup>	V	
		*5: This detection voltage level setting is below the minimum operation assurance voltage (2.7V*4 or 4.0V*3). Between this detection voltage and the minimum operation assurance voltage, MCU functions are not guaranteed except for the low voltage detector.								
		Note that although the detection level is below the minimum operation guarantee voltage, the LVD reset factor flag is set as the voltage drops below the detection level.								
		Correct)								
		Parameter	Symbol	Pin Name	Conditions	Value			Unit	Remarks
						Min	Typ	Max		
		Supply voltage range	V <sub>DP5</sub>	VCC5	-	3.5 <sup>*3</sup>	-	5.5 <sup>*3</sup>	V	
			V <sub>DP3</sub>	VCC3	-	2.7	-	3.6	V	
		Detection voltage (before trimming)	V <sub>DLBT</sub>	VCC5	*1	3.6 <sup>*3</sup>	4.0 <sup>*3</sup>	4.4 <sup>*3</sup>	V	When power-supply voltage falls and detection level is set initially
				VCC3	*1 <sup>*5</sup>	2.3	2.6	2.9	V	
		Detection voltage (after trimming)	V <sub>DLAT</sub>	VCC5	*1	3.86 <sup>*3</sup>	4.0 <sup>*3</sup>	4.14 <sup>*3</sup>	V	When power-supply voltage falls and detection level is set initially
				VCC3	*1 <sup>*5</sup>	2.51 <sup>*4</sup>	2.6 <sup>*4</sup>	2.69 <sup>*4</sup>	V	
		*5: These LVD settings cannot be used to reliably generate a reset before voltage dips below minimum guaranteed MCU operation voltage, as these detection levels are below the minimum guaranteed MCU operation voltage(2.7V).								

Page	Section	Change Results								
227	9. Electric Characteristics 9.1.4.11 Low Voltage Detection (External Voltage)	Low-voltage detection (1.15 V power supply low-voltage detection) Error)								
		Parameter	Symbol	Pin Name	Conditions	Value			Unit	Remarks
						Min	Typ	Max		
		Supply voltage range	V <sub>RDP12</sub>	VCC12	-	1.09	-	1.21	V	
		Detection voltage (before trimming)	V <sub>RDLBT</sub>	VCC12	*1	0.7125	0.8125	0.9125	V	When power-supply voltage falls
		Detection voltage (after trimming)	V <sub>RDLAT</sub>	VCC12	*1	0.7841	0.8125	0.841	V	When power-supply voltage falls Typ±3.5% *2
		*2: This detection voltage level setting is below the minimum operation assurance voltage . Between this detection voltage and the minimum operation assurance voltage, MCU functions are not guaranteed except for the low voltage detector. Note that although the detection level is below the minimum operation guarantee voltage, the LVD reset factor flag is set as the voltage drops below the detection level.								
		Correct)								
		Parameter	Symbol	Pin Name	Conditions	Value			Unit	Remarks
						Min	Typ	Max		
		Supply voltage range	V <sub>RDP12</sub>	VCC12	-	1.09	-	1.21	V	
		Detection voltage (before trimming)	V <sub>RDLBT</sub>	VCC12	*1 *2	0.7125	0.8125	0.9125	V	When power-supply voltage falls
		Detection voltage (after trimming)	V <sub>RDLAT</sub>	VCC12	*1 *2	0.7841	0.8125	0.841	V	When power-supply voltage falls Typ±3.5%
		*2: These LVD settings cannot be used to reliably generate a reset before voltage dips below minimum guaranteed MCU operation voltage, as these detection levels are below the minimum guaranteed MCU operation voltage (1.09V).								



Page	Section	Change Results								
228	9. Electric Characteristics 9.1.4.12 Low Voltage Detection (Internal Voltage)	Low-voltage detection (internal low-voltage detection for LVDL1) Error)								
		Parameter	Symbol	Pin Name	Conditions	Value			Unit	Remarks
						Min	Typ	Max		
		Supply voltage range	$V_{RDP5}$	-	-	1.05	-	1.21	V	
		Detection voltage	$V_{RDLBT}$	-	*1	0.775	0.875	0.975	V	When power-supply voltage falls <sup>*3</sup>
		Detection voltage	$V_{RDLAT}$	-	*1	0.844	0.875	0.906	V	When power-supply voltage falls Typ±3.5% <sup>*2 *3</sup>
		Hysteresis width	$V_{RHYS}$	-	-	-	75	-	mV	When power-supply voltage rises
		Low-voltage detection time	TRd	-	-	-	-	30	μs	<sup>*4</sup>
		<p><sup>*2</sup>: This detection voltage level setting is below the minimum operation assurance voltage . Between this detection voltage and the minimum operation assurance voltage, MCU functions are not guaranteed except for the low voltage detector. Note that although the detection level is below the minimum operation guarantee voltage, the LVD reset factor flag is set as the voltage drops below the detection level.</p> <p><sup>*3</sup>: This LVD cannot be used to reliably generate a reset before voltage dips below minimum guaranteed MCU operation voltage, as these detection levels are below the minimum guaranteed MCU operation voltage.</p> <p><sup>*4</sup>: After the brown-out event where the voltage level dips below the detection threshold for less than this time, the detection may occur or be canceled.</p>								

Page	Section	Change Results								
		Correct)								
		Parameter	Symbol	Pin Name	Conditions	Value			Unit	Remarks
						Min	Typ	Max		
		Supply voltage range	V <sub>RDP5</sub>	-	-	1.05	-	1.21	V	
		Detection voltage (before trimming)	V <sub>RDLBT</sub>	-	*1*2	0.775	0.875	0.975	V	When power-supply voltage falls
		Detection voltage (after trimming)	V <sub>RDLAT</sub>	-	*1*2	0.844	0.875	0.906	V	When power-supply voltage falls Typ±3.5%
		Hysteresis width	V <sub>RHYS</sub>	-	-	-	75	-	mV	When power-supply voltage rises
		Low-voltage detection time	TRd	-	-	-	-	30	µs	*3
		<p>*2: This LVD cannot be used to reliably generate a reset before voltage dips below minimum guaranteed MCU operation voltage, as these detection levels are below the minimum guaranteed MCU operation voltage.</p> <p>*3: After the brown-out event where the voltage level dips below the detection threshold for less than this time, the detection may occur or be canceled.</p>								
248	9. Electric Characteristics 9.1.4.21 LCD bus I/F	Error) - Correct) All change								
249 250 251 252	9. Electric Characteristics 9.1.4.22 Power and Reset Sequence	Error) - Correct) Newly added								

Page	Section	Change Results																				
263	11. Ordering Information	Error) <table border="1" data-bbox="427 325 1161 997"> <thead> <tr> <th>Part Number</th> <th>Package</th> </tr> </thead> <tbody> <tr> <td>S6J331EKCC*****</td> <td>208-pin plastic TEQFP (TEQFP208)</td> </tr> <tr> <td>S6J331EKBC*****</td> <td>208-pin plastic TEQFP (TEQFP208)</td> </tr> <tr> <td>S6J331EKAC*****</td> <td>208-pin plastic TEQFP (TEQFP208)</td> </tr> <tr> <td>S6J331EJCC*****</td> <td>176-pin plastic TEQFP (TEQFP176)</td> </tr> <tr> <td>S6J332EJCC*****</td> <td>176-pin plastic TEQFP (TEQFP176)</td> </tr> <tr> <td>S6J331EJAC*****</td> <td>176-pin plastic TEQFP (TEQFP176)</td> </tr> <tr> <td>S6J332EJAC*****</td> <td>176-pin plastic TEQFP (TEQFP176)</td> </tr> <tr> <td>S6J332EHSC*****</td> <td>144-pin plastic TEQFP (TEQFP144)</td> </tr> <tr> <td>S6J332EHSC*****</td> <td>144-pin plastic TEQFP (TEQFP144)</td> </tr> </tbody> </table>	Part Number	Package	S6J331EKCC*****	208-pin plastic TEQFP (TEQFP208)	S6J331EKBC*****	208-pin plastic TEQFP (TEQFP208)	S6J331EKAC*****	208-pin plastic TEQFP (TEQFP208)	S6J331EJCC*****	176-pin plastic TEQFP (TEQFP176)	S6J332EJCC*****	176-pin plastic TEQFP (TEQFP176)	S6J331EJAC*****	176-pin plastic TEQFP (TEQFP176)	S6J332EJAC*****	176-pin plastic TEQFP (TEQFP176)	S6J332EHSC*****	144-pin plastic TEQFP (TEQFP144)	S6J332EHSC*****	144-pin plastic TEQFP (TEQFP144)
Part Number	Package																					
S6J331EKCC*****	208-pin plastic TEQFP (TEQFP208)																					
S6J331EKBC*****	208-pin plastic TEQFP (TEQFP208)																					
S6J331EKAC*****	208-pin plastic TEQFP (TEQFP208)																					
S6J331EJCC*****	176-pin plastic TEQFP (TEQFP176)																					
S6J332EJCC*****	176-pin plastic TEQFP (TEQFP176)																					
S6J331EJAC*****	176-pin plastic TEQFP (TEQFP176)																					
S6J332EJAC*****	176-pin plastic TEQFP (TEQFP176)																					
S6J332EHSC*****	144-pin plastic TEQFP (TEQFP144)																					
S6J332EHSC*****	144-pin plastic TEQFP (TEQFP144)																					

Page	Section	Change Results																																		
		<p>Correct)</p> <table border="1"> <thead> <tr> <th>Part Number *1</th> <th>Package</th> </tr> </thead> <tbody> <tr> <td>S6J331EKEx*****</td> <td>208-pin plastic TEQFP (LEW208)</td> </tr> <tr> <td>S6J332CKSx*****</td> <td>208-pin plastic TEQFP (LEW208)</td> </tr> <tr> <td>S6J334CKSx*****</td> <td>208-pin plastic TEQFP (LEW208)</td> </tr> <tr> <td>S6J331EJAx*****</td> <td>176-pin plastic TEQFP (LEW176)</td> </tr> <tr> <td>S6J332CJBx*****</td> <td>176-pin plastic TEQFP (LEW176)</td> </tr> <tr> <td>S6J332CJT*****</td> <td>176-pin plastic TEQFP (LEW176)</td> </tr> <tr> <td>S6J332EJBx*****</td> <td>176-pin plastic TEQFP (LEW176)</td> </tr> <tr> <td>S6J334BJDx*****</td> <td>176-pin plastic TEQFP (LEW176)</td> </tr> <tr> <td>S6J334CJEx*****</td> <td>176-pin plastic TEQFP (LEW176)</td> </tr> <tr> <td>S6J334CJT*****</td> <td>176-pin plastic TEQFP (LEW176)</td> </tr> <tr> <td>S6J334DJEx*****</td> <td>176-pin plastic TEQFP (LEW176)</td> </tr> <tr> <td>S6J334DJT*****</td> <td>176-pin plastic TEQFP (LEW176)</td> </tr> <tr> <td>S6J334EJAx*****</td> <td>176-pin plastic TEQFP (LEW176)</td> </tr> <tr> <td>S6J334EJEx*****</td> <td>176-pin plastic TEQFP (LEW176)</td> </tr> <tr> <td>S6J334EJT*****</td> <td>176-pin plastic TEQFP (LEW176)</td> </tr> <tr> <td>S6J334CHBx*****</td> <td>144-pin plastic TEQFP (LEX144, LEK144)</td> </tr> </tbody> </table> <p>*1: x is selected from the following parameter. x : C, D (Revision)</p>	Part Number *1	Package	S6J331EKEx*****	208-pin plastic TEQFP (LEW208)	S6J332CKSx*****	208-pin plastic TEQFP (LEW208)	S6J334CKSx*****	208-pin plastic TEQFP (LEW208)	S6J331EJAx*****	176-pin plastic TEQFP (LEW176)	S6J332CJBx*****	176-pin plastic TEQFP (LEW176)	S6J332CJT*****	176-pin plastic TEQFP (LEW176)	S6J332EJBx*****	176-pin plastic TEQFP (LEW176)	S6J334BJDx*****	176-pin plastic TEQFP (LEW176)	S6J334CJEx*****	176-pin plastic TEQFP (LEW176)	S6J334CJT*****	176-pin plastic TEQFP (LEW176)	S6J334DJEx*****	176-pin plastic TEQFP (LEW176)	S6J334DJT*****	176-pin plastic TEQFP (LEW176)	S6J334EJAx*****	176-pin plastic TEQFP (LEW176)	S6J334EJEx*****	176-pin plastic TEQFP (LEW176)	S6J334EJT*****	176-pin plastic TEQFP (LEW176)	S6J334CHBx*****	144-pin plastic TEQFP (LEX144, LEK144)
Part Number *1	Package																																			
S6J331EKEx*****	208-pin plastic TEQFP (LEW208)																																			
S6J332CKSx*****	208-pin plastic TEQFP (LEW208)																																			
S6J334CKSx*****	208-pin plastic TEQFP (LEW208)																																			
S6J331EJAx*****	176-pin plastic TEQFP (LEW176)																																			
S6J332CJBx*****	176-pin plastic TEQFP (LEW176)																																			
S6J332CJT*****	176-pin plastic TEQFP (LEW176)																																			
S6J332EJBx*****	176-pin plastic TEQFP (LEW176)																																			
S6J334BJDx*****	176-pin plastic TEQFP (LEW176)																																			
S6J334CJEx*****	176-pin plastic TEQFP (LEW176)																																			
S6J334CJT*****	176-pin plastic TEQFP (LEW176)																																			
S6J334DJEx*****	176-pin plastic TEQFP (LEW176)																																			
S6J334DJT*****	176-pin plastic TEQFP (LEW176)																																			
S6J334EJAx*****	176-pin plastic TEQFP (LEW176)																																			
S6J334EJEx*****	176-pin plastic TEQFP (LEW176)																																			
S6J334EJT*****	176-pin plastic TEQFP (LEW176)																																			
S6J334CHBx*****	144-pin plastic TEQFP (LEX144, LEK144)																																			

Rev. \*E

6	2. Function List 2.1 Function list	<p>Revised the below:</p> <p>CAN-FD RAM (ECC supported) Error) 16KB/ch It equivalent to 128 message buffer per channel of <b>CCAN</b> module</p> <p>Correct) 16KB/ch It equivalent to 128 message buffer per channel of <b>MCAN</b> module</p>
---	---------------------------------------	--

Page	Section	Change Results																																											
12	3. Product Description 3.2 Product description	<p>Error)</p> <table border="1"> <tr> <td>Power Supply</td> <td>3V external power supply <b>should</b> be controlled by GPIO.</td> </tr> </table> <p>Correct)</p> <table border="1"> <tr> <td>Power Supply</td> <td>3V external power supply <b>could</b> be controlled by GPIO.</td> </tr> </table>	Power Supply	3V external power supply <b>should</b> be controlled by GPIO.	Power Supply	3V external power supply <b>could</b> be controlled by GPIO.																																							
Power Supply	3V external power supply <b>should</b> be controlled by GPIO.																																												
Power Supply	3V external power supply <b>could</b> be controlled by GPIO.																																												
61	7. Port configuration 7.1 Resource Input Configuration Module	<p>Error)</p> <p>-</p> <p>Correct)</p> <p>The Resource which are available through only one port does not have the multiplexer implemented i.e. No RIC_RESIN register.</p>																																											
169	9. Electric Characteristics 9.1.1 Absolute Maximum Rating	<p>Error)</p> <table border="1"> <tr> <td>Power supply voltage<sup>*1, *2</sup></td> <td>V<sub>CC12</sub></td> <td>V<sub>SS-0.3</sub></td> <td>V<sub>SS+1.8</sub></td> <td>V</td> <td>V<sub>CC12</sub> ≤ V<sub>CC53</sub> V<sub>CC12</sub> ≤ V<sub>CC3</sub> V<sub>CC12</sub> ≤ DV<sub>CC</sub> V<sub>CC12</sub> ≤ AV<sub>CC5</sub></td> </tr> </table> <p>Correct)</p> <table border="1"> <tr> <td>Power supply voltage<sup>*1, *2</sup></td> <td>V<sub>CC12</sub></td> <td>V<sub>SS-0.3</sub></td> <td>V<sub>SS+1.8</sub></td> <td>V</td> <td>V<sub>CC12</sub> ≤ AV<sub>CC5</sub></td> </tr> </table>	Power supply voltage <sup>*1, *2</sup>	V <sub>CC12</sub>	V <sub>SS-0.3</sub>	V <sub>SS+1.8</sub>	V	V <sub>CC12</sub> ≤ V <sub>CC53</sub> V <sub>CC12</sub> ≤ V <sub>CC3</sub> V <sub>CC12</sub> ≤ DV <sub>CC</sub> V <sub>CC12</sub> ≤ AV <sub>CC5</sub>	Power supply voltage <sup>*1, *2</sup>	V <sub>CC12</sub>	V <sub>SS-0.3</sub>	V <sub>SS+1.8</sub>	V	V <sub>CC12</sub> ≤ AV <sub>CC5</sub>																															
Power supply voltage <sup>*1, *2</sup>	V <sub>CC12</sub>	V <sub>SS-0.3</sub>	V <sub>SS+1.8</sub>	V	V <sub>CC12</sub> ≤ V <sub>CC53</sub> V <sub>CC12</sub> ≤ V <sub>CC3</sub> V <sub>CC12</sub> ≤ DV <sub>CC</sub> V <sub>CC12</sub> ≤ AV <sub>CC5</sub>																																								
Power supply voltage <sup>*1, *2</sup>	V <sub>CC12</sub>	V <sub>SS-0.3</sub>	V <sub>SS+1.8</sub>	V	V <sub>CC12</sub> ≤ AV <sub>CC5</sub>																																								
169	9. Electric Characteristics 9.1.1 Absolute Maximum Rating	<p>Error)</p> <table border="1"> <tr> <td>Total maximum clamp current</td> <td>Σ I<sub>CLAMP</sub> </td> <td>-</td> <td>50</td> <td>mA</td> <td>SPECIAL SPEC<sup>*A</sup></td> </tr> </table> <p>Correct)</p> <table border="1"> <tr> <td>Total maximum clamp current</td> <td>Σ I<sub>CLAMP</sub> </td> <td>-</td> <td>90</td> <td>mA</td> <td><sup>*B</sup></td> </tr> <tr> <td>Total maximum clamp current</td> <td>Σ I<sub>CLAMP</sub> </td> <td>-</td> <td>65</td> <td>mA</td> <td><sup>*C</sup></td> </tr> </table>	Total maximum clamp current	Σ I <sub>CLAMP</sub>	-	50	mA	SPECIAL SPEC <sup>*A</sup>	Total maximum clamp current	Σ I <sub>CLAMP</sub>	-	90	mA	<sup>*B</sup>	Total maximum clamp current	Σ I <sub>CLAMP</sub>	-	65	mA	<sup>*C</sup>																									
Total maximum clamp current	Σ I <sub>CLAMP</sub>	-	50	mA	SPECIAL SPEC <sup>*A</sup>																																								
Total maximum clamp current	Σ I <sub>CLAMP</sub>	-	90	mA	<sup>*B</sup>																																								
Total maximum clamp current	Σ I <sub>CLAMP</sub>	-	65	mA	<sup>*C</sup>																																								
170	9. Electric Characteristics 9.1.1 Absolute Maximum Rating	<p>Error)</p> <p>-</p> <p>Correct)</p> <table border="1"> <tr> <td rowspan="4">System Thermal Resistance</td> <td>Theta j-a1</td> <td>-</td> <td>17</td> <td>°C/W</td> <td>TEQFP 208</td> <td rowspan="4">The minimum value depends on the system specification of heat radiation. The described value is estimated under the condition which is specified at "9.1.2 Recommended Operating Conditions".</td> </tr> <tr> <td>Theta j-a2</td> <td>-</td> <td>19</td> <td>°C/W</td> <td>TEQFP 176</td> </tr> <tr> <td>Theta j-a3</td> <td>-</td> <td>20</td> <td>°C/W</td> <td>TEQFP 144 (0.5mm Pitch)</td> </tr> <tr> <td>Theta j-a4</td> <td>-</td> <td>22</td> <td>°C/W</td> <td>TEQFP 144 (0.4mm Pitch)</td> </tr> <tr> <td rowspan="4">Package Thermal Resistance</td> <td>Psi j-t1</td> <td>-</td> <td>0.6</td> <td>°C/W</td> <td>TEQFP208</td> </tr> <tr> <td>Psi j-t2</td> <td>-</td> <td>1.0</td> <td>°C/W</td> <td>TEQFP176</td> </tr> <tr> <td>Psi j-t3</td> <td>-</td> <td>2.0</td> <td>°C/W</td> <td>TEQFP144 (0.5mm Pitch)</td> </tr> <tr> <td>Psi j-t4</td> <td>-</td> <td>2.0</td> <td>°C/W</td> <td>TEQFP144 (0.4mm Pitch)</td> </tr> </table>	System Thermal Resistance	Theta j-a1	-	17	°C/W	TEQFP 208	The minimum value depends on the system specification of heat radiation. The described value is estimated under the condition which is specified at "9.1.2 Recommended Operating Conditions".	Theta j-a2	-	19	°C/W	TEQFP 176	Theta j-a3	-	20	°C/W	TEQFP 144 (0.5mm Pitch)	Theta j-a4	-	22	°C/W	TEQFP 144 (0.4mm Pitch)	Package Thermal Resistance	Psi j-t1	-	0.6	°C/W	TEQFP208	Psi j-t2	-	1.0	°C/W	TEQFP176	Psi j-t3	-	2.0	°C/W	TEQFP144 (0.5mm Pitch)	Psi j-t4	-	2.0	°C/W	TEQFP144 (0.4mm Pitch)
System Thermal Resistance	Theta j-a1	-		17	°C/W	TEQFP 208	The minimum value depends on the system specification of heat radiation. The described value is estimated under the condition which is specified at "9.1.2 Recommended Operating Conditions".																																						
	Theta j-a2	-		19	°C/W	TEQFP 176																																							
	Theta j-a3	-		20	°C/W	TEQFP 144 (0.5mm Pitch)																																							
	Theta j-a4	-	22	°C/W	TEQFP 144 (0.4mm Pitch)																																								
Package Thermal Resistance	Psi j-t1	-	0.6	°C/W	TEQFP208																																								
	Psi j-t2	-	1.0	°C/W	TEQFP176																																								
	Psi j-t3	-	2.0	°C/W	TEQFP144 (0.5mm Pitch)																																								
	Psi j-t4	-	2.0	°C/W	TEQFP144 (0.4mm Pitch)																																								

Page	Section	Change Results
172	9. Electric	Error)
173	Characteristics	-
174	9. 1 Electric Characteristics	Correct) Newly added *B Relevant pins: All general-purpose ports and analog input pins *C Relevant pins: All general-purpose ports and analog input pins
176	9. Electric Characteristics 9.1.2 Recommended operating condition	<p>Error)</p> <p>- In the case of use in <math>VCC5 = AVCC5 = DVCC</math> of conditions, please launch the power supply in the following sequence.</p> <p>Required power supply sequence is the following:  <math>VCC5 \rightarrow [DVCC \text{ or } VCC53 \text{ or } AVCC5 \text{ or } VCC3 \text{ or } AVCC3\_DAC] \rightarrow VCC12</math></p> <p>Note that power supplies inside "[ ]" can be turned on in arbitrary order.  Corresponding Part number is S6J33xxxSC or S6J33xxxUC or S6J33xxxTC or S6J33xxxVC or S6J33xxxBC or S6J33xxxDC or S6J33xxxFC or S6J33xxxHC.</p> <p>- In the case of use in <math>VCC5 = AVCC5 &lt; DVCC</math> of conditions, please launch the power supply in the following sequence.</p> <p>Required power supply sequence is the following:  <math>VCC5 \rightarrow DVCC \rightarrow [VCC53 \text{ or } AVCC5 \text{ or } VCC3 \text{ or } AVCC3\_DAC] \rightarrow VCC12.</math></p> <p>Note that power supplies inside "[ ]" can be turned on in arbitrary order.  Corresponding Part number is S6J33xxxAC or S6J33xxxCC or S6J33xxxEC or S6J33xxxGC.</p> <p>Correct)</p> <p>- Required power supply sequence is the following:  <math>\{VCC5 \rightarrow AVCC5\} \rightarrow [DVCC, VCC12, VCC3, AVCC3\_DAC]</math></p> <p>Note that power supplies inside "[ ]" can be turned on in arbitrary order and "{ }" can be turned on in shown sequence or simultaneously.</p>

Page	Section	Change Results
177	9. Electric Characteristics 9.1.2 Recommended operating condition	<p>Error)</p> <p>-</p> <p>Correct)</p> <p>Note:</p> <ul style="list-style-type: none"> <li>-TA: Ambient temperature (JEDEC)</li> <li>-TC: Case temperature (JEDEC), the maximum measured temperature of package case top.</li> <li>-Both rating of TA and TC should simultaneously be satisfied as maximum operation temperature.</li> <li>-The following condition should be satisfied in order to facilitate heat dissipation.</li> </ul> <ol style="list-style-type: none"> <li>1. Four or more layers PCB should be used.</li> <li>2. The area of PCB should be 114.3 mm x 76.2 mm or more, and the thickness should be 1.6 mm or more. (JEDEC standard)</li> <li>3. One layer of middle layers at least should be used for dedicated layer to radiate heat with residual copper rate 90% or more. The layer can be used for system ground.</li> <li>4. 35% or more of the die stage area which is exposed at back surface of package should be soldered to a part of 1st layer.</li> <li>5. The part of 1st layer should be connected to the dedicated heat radiation layer with more than 10 thermal via holes.</li> </ol> <p>Example thermal via holes on PCB</p> <p>&lt;Figure&gt;</p> <ul style="list-style-type: none"> <li>- The above figure is a schematic diagram showing PCB in section.</li> <li>- Thermal via holes should closely be placed and aligned with lands.</li> <li>- It is recommended to connect the land pattern to the VSS-ground level (GND plan of inner layer bellow the MCU) as thermal heat sink.</li> </ul>

Page	Section	Change Results																																																																									
185	9. Electric Characteristics 9.1.3 DC characteristics	<p>Error)</p> <table border="1"> <thead> <tr> <th rowspan="2">Parameter</th> <th rowspan="2">Symbol</th> <th rowspan="2">Pin Name</th> <th rowspan="2">Conditions</th> <th colspan="3">Value</th> <th rowspan="2">Unit</th> <th rowspan="2">Remarks</th> </tr> <tr> <th>Min</th> <th>Typ</th> <th>Max</th> </tr> </thead> <tbody> <tr> <td rowspan="3">Power supply current</td> <td rowspan="2">I<sub>CC12</sub></td> <td rowspan="3">VCC 12</td> <td>Normal operation</td> <td>-</td> <td>500</td> <td>1000</td> <td>mA</td> <td>T<sub>A</sub>=-40 ~ 105°C CPU:240MHz, HPM:120MHz (CPU:200MHz, HPM:200MHz) GDC : 200MHz</td> </tr> <tr> <td>Flash write/erase</td> <td>-</td> <td>550</td> <td>1050</td> <td>mA</td> <td>T<sub>A</sub>=-40 ~ 105°C CPU:240MHz, HPM:120MHz (CPU:200MHz, HPM:200MHz) GDC : 200MHz</td> </tr> <tr> <td>I<sub>CCH12</sub></td> <td>Timer/ Stop Mode</td> <td>-</td> <td>-</td> <td>650</td> <td>mA</td> <td></td> </tr> </tbody> </table> <p>Correct)</p> <table border="1"> <thead> <tr> <th rowspan="2">Parameter</th> <th rowspan="2">Symbol</th> <th rowspan="2">Pin Name</th> <th rowspan="2">Conditions</th> <th colspan="3">Value</th> <th rowspan="2">Unit</th> <th rowspan="2">Remarks</th> </tr> <tr> <th>Min</th> <th>Typ</th> <th>Max</th> </tr> </thead> <tbody> <tr> <td rowspan="4">Power supply current</td> <td rowspan="3">I<sub>CC12</sub></td> <td rowspan="4">VCC 12</td> <td rowspan="2">Normal operation</td> <td>-</td> <td>320</td> <td>800</td> <td>mA</td> <td>T<sub>A</sub>=-40 ~ 105°C CPU:240MHz, HPM:120MHz (CPU:200MHz, HPM:200MHz) GDC : 200MHz</td> </tr> <tr> <td>-</td> <td>-</td> <td>395</td> <td>mA</td> <td>Example use case *1 T<sub>A</sub>=-40 ~ 105°C CPU:60MHz, HPM:60MHz GDC : 60MHz</td> </tr> <tr> <td>Flash write/erase</td> <td>-</td> <td>350</td> <td>850</td> <td>mA</td> <td>T<sub>A</sub>=-40 ~ 105°C CPU:240MHz, HPM:120MHz (CPU:200MHz, HPM:200MHz) GDC : 200MHz</td> </tr> <tr> <td>I<sub>CCH12</sub></td> <td>Timer/ Stop Mode</td> <td>-</td> <td>-</td> <td>430</td> <td>mA</td> <td></td> </tr> </tbody> </table>	Parameter	Symbol	Pin Name	Conditions	Value			Unit	Remarks	Min	Typ	Max	Power supply current	I <sub>CC12</sub>	VCC 12	Normal operation	-	500	1000	mA	T <sub>A</sub> =-40 ~ 105°C CPU:240MHz, HPM:120MHz (CPU:200MHz, HPM:200MHz) GDC : 200MHz	Flash write/erase	-	550	1050	mA	T <sub>A</sub> =-40 ~ 105°C CPU:240MHz, HPM:120MHz (CPU:200MHz, HPM:200MHz) GDC : 200MHz	I <sub>CCH12</sub>	Timer/ Stop Mode	-	-	650	mA		Parameter	Symbol	Pin Name	Conditions	Value			Unit	Remarks	Min	Typ	Max	Power supply current	I <sub>CC12</sub>	VCC 12	Normal operation	-	320	800	mA	T <sub>A</sub> =-40 ~ 105°C CPU:240MHz, HPM:120MHz (CPU:200MHz, HPM:200MHz) GDC : 200MHz	-	-	395	mA	Example use case *1 T <sub>A</sub> =-40 ~ 105°C CPU:60MHz, HPM:60MHz GDC : 60MHz	Flash write/erase	-	350	850	mA	T <sub>A</sub> =-40 ~ 105°C CPU:240MHz, HPM:120MHz (CPU:200MHz, HPM:200MHz) GDC : 200MHz	I <sub>CCH12</sub>	Timer/ Stop Mode	-	-	430	mA	
Parameter	Symbol	Pin Name					Conditions	Value				Unit	Remarks																																																														
			Min	Typ	Max																																																																						
Power supply current	I <sub>CC12</sub>	VCC 12	Normal operation	-	500	1000	mA	T <sub>A</sub> =-40 ~ 105°C CPU:240MHz, HPM:120MHz (CPU:200MHz, HPM:200MHz) GDC : 200MHz																																																																			
			Flash write/erase	-	550	1050	mA	T <sub>A</sub> =-40 ~ 105°C CPU:240MHz, HPM:120MHz (CPU:200MHz, HPM:200MHz) GDC : 200MHz																																																																			
	I <sub>CCH12</sub>		Timer/ Stop Mode	-	-	650	mA																																																																				
Parameter	Symbol	Pin Name	Conditions	Value			Unit	Remarks																																																																			
				Min	Typ	Max																																																																					
Power supply current	I <sub>CC12</sub>	VCC 12	Normal operation	-	320	800	mA	T <sub>A</sub> =-40 ~ 105°C CPU:240MHz, HPM:120MHz (CPU:200MHz, HPM:200MHz) GDC : 200MHz																																																																			
				-	-	395	mA	Example use case *1 T <sub>A</sub> =-40 ~ 105°C CPU:60MHz, HPM:60MHz GDC : 60MHz																																																																			
			Flash write/erase	-	350	850	mA	T <sub>A</sub> =-40 ~ 105°C CPU:240MHz, HPM:120MHz (CPU:200MHz, HPM:200MHz) GDC : 200MHz																																																																			
	I <sub>CCH12</sub>		Timer/ Stop Mode	-	-	430	mA																																																																				
186	9. Electric Characteristics 9.1.3 DC characteristics	<p>Error)</p> <p>-</p> <p>Correct)</p> <p>*1 : Example use case at following condition CPU:60MHz, HPM:60MHz, GDC : 60MHz Peripherals: - DMAC active (WorkFlash =&gt; SystemRAM) - All timers active - 6 SMCs, 1 CAN, 2LIN, 1SPI, PWMs, ADCs Display controller: - 2 (= all) layers active (60 MHz, noise RGBA, 32 bpp, 2048 x 5 pixels) - Any other resources inactive - IOs no toggle</p>																																																																									



Page	Section	Change Results																																																													
254	9. Electric	Error)																																																													
255	Characteristics	-																																																													
256	9.1.4.22 Power and Reset Sequence	Correct) Newly added Case-1, Case2-1 and Case2-2																																																													
266	9. Electric Characteristics 9.1.7.1 Electrical Characteristics	Error)																																																													
<table border="1"> <thead> <tr> <th rowspan="2">Parameter</th> <th colspan="3">Rating</th> <th rowspan="2">Unit</th> <th rowspan="2">Remarks</th> </tr> <tr> <th>Min</th> <th>Typ</th> <th>Max<sup>*3</sup></th> </tr> </thead> <tbody> <tr> <td rowspan="3">Sector erase time</td> <td>-</td> <td>120</td> <td>480</td> <td>ms</td> <td>Large sector<sup>*1</sup> Internal preprogramming time included</td> </tr> <tr> <td>-</td> <td>120</td> <td>480</td> <td>ms</td> <td>8kB sector<sup>*1</sup> Internal preprogramming time included</td> </tr> <tr> <td>-</td> <td>120</td> <td>480</td> <td>ms</td> <td>4kB sector<sup>*1</sup> Internal preprogramming time included</td> </tr> <tr> <td>16bit write time(Program)</td> <td>-</td> <td>30</td> <td>384</td> <td>μs</td> <td>System-level overhead time excluded<sup>*1</sup></td> </tr> <tr> <td>32bit write time(Program)</td> <td>-</td> <td>30</td> <td>384</td> <td>μs</td> <td>System-level overhead time excluded<sup>*1</sup></td> </tr> <tr> <td>64bit write time(Program)</td> <td>-</td> <td>30</td> <td>384</td> <td>μs</td> <td>System-level overhead time excluded<sup>*1</sup></td> </tr> <tr> <td>256bit write time(Program)</td> <td>-</td> <td>40</td> <td>512</td> <td>μs</td> <td>System-level overhead time excluded<sup>*1</sup></td> </tr> <tr> <td>Page mode write time(Program)</td> <td>-</td> <td>320</td> <td>4096</td> <td>μs</td> <td>System-level overhead time excluded<sup>*1</sup></td> </tr> <tr> <td>32bit write time(Work)</td> <td>-</td> <td>30</td> <td>384</td> <td>μs</td> <td>System-level overhead time excluded<sup>*1</sup></td> </tr> </tbody> </table>			Parameter	Rating			Unit	Remarks	Min	Typ	Max <sup>*3</sup>	Sector erase time	-	120	480	ms	Large sector <sup>*1</sup> Internal preprogramming time included	-	120	480	ms	8kB sector <sup>*1</sup> Internal preprogramming time included	-	120	480	ms	4kB sector <sup>*1</sup> Internal preprogramming time included	16bit write time(Program)	-	30	384	μs	System-level overhead time excluded <sup>*1</sup>	32bit write time(Program)	-	30	384	μs	System-level overhead time excluded <sup>*1</sup>	64bit write time(Program)	-	30	384	μs	System-level overhead time excluded <sup>*1</sup>	256bit write time(Program)	-	40	512	μs	System-level overhead time excluded <sup>*1</sup>	Page mode write time(Program)	-	320	4096	μs	System-level overhead time excluded <sup>*1</sup>	32bit write time(Work)	-	30	384	μs	System-level overhead time excluded <sup>*1</sup>
Parameter	Rating			Unit	Remarks																																																										
	Min	Typ	Max <sup>*3</sup>																																																												
Sector erase time	-	120	480	ms	Large sector <sup>*1</sup> Internal preprogramming time included																																																										
	-	120	480	ms	8kB sector <sup>*1</sup> Internal preprogramming time included																																																										
	-	120	480	ms	4kB sector <sup>*1</sup> Internal preprogramming time included																																																										
16bit write time(Program)	-	30	384	μs	System-level overhead time excluded <sup>*1</sup>																																																										
32bit write time(Program)	-	30	384	μs	System-level overhead time excluded <sup>*1</sup>																																																										
64bit write time(Program)	-	30	384	μs	System-level overhead time excluded <sup>*1</sup>																																																										
256bit write time(Program)	-	40	512	μs	System-level overhead time excluded <sup>*1</sup>																																																										
Page mode write time(Program)	-	320	4096	μs	System-level overhead time excluded <sup>*1</sup>																																																										
32bit write time(Work)	-	30	384	μs	System-level overhead time excluded <sup>*1</sup>																																																										
Correct)																																																															
<table border="1"> <thead> <tr> <th rowspan="2">Parameter</th> <th colspan="3">Rating</th> <th rowspan="2">Unit</th> <th rowspan="2">Remarks</th> </tr> <tr> <th>Min</th> <th>Typ</th> <th>Max<sup>*3</sup></th> </tr> </thead> <tbody> <tr> <td rowspan="3">Sector erase time</td> <td>-</td> <td>120</td> <td>180</td> <td>ms</td> <td>Large sector<sup>*1</sup> Internal preprogramming time included</td> </tr> <tr> <td>-</td> <td>120</td> <td>180</td> <td>ms</td> <td>8kB sector<sup>*1</sup> Internal preprogramming time included</td> </tr> <tr> <td>-</td> <td>120</td> <td>180</td> <td>ms</td> <td>4kB sector<sup>*1</sup> Internal preprogramming time included</td> </tr> <tr> <td>16bit write time(Program)</td> <td>-</td> <td>30</td> <td>60</td> <td>μs</td> <td>System-level overhead time excluded<sup>*1</sup></td> </tr> <tr> <td>32bit write time(Program)</td> <td>-</td> <td>30</td> <td>60</td> <td>μs</td> <td>System-level overhead time excluded<sup>*1</sup></td> </tr> <tr> <td>64bit write time(Program)</td> <td>-</td> <td>30</td> <td>60</td> <td>μs</td> <td>System-level overhead time excluded<sup>*1</sup></td> </tr> <tr> <td>256bit write time(Program)</td> <td>-</td> <td>40</td> <td>70</td> <td>μs</td> <td>System-level overhead time excluded<sup>*1</sup></td> </tr> <tr> <td>Page mode write time(Program)</td> <td>-</td> <td>320</td> <td>600</td> <td>μs</td> <td>System-level overhead time excluded<sup>*1</sup></td> </tr> <tr> <td>32bit write time(Work)</td> <td>-</td> <td>30</td> <td>60</td> <td>μs</td> <td>System-level overhead time excluded<sup>*1</sup></td> </tr> </tbody> </table>			Parameter	Rating			Unit	Remarks	Min	Typ	Max <sup>*3</sup>	Sector erase time	-	120	180	ms	Large sector <sup>*1</sup> Internal preprogramming time included	-	120	180	ms	8kB sector <sup>*1</sup> Internal preprogramming time included	-	120	180	ms	4kB sector <sup>*1</sup> Internal preprogramming time included	16bit write time(Program)	-	30	60	μs	System-level overhead time excluded <sup>*1</sup>	32bit write time(Program)	-	30	60	μs	System-level overhead time excluded <sup>*1</sup>	64bit write time(Program)	-	30	60	μs	System-level overhead time excluded <sup>*1</sup>	256bit write time(Program)	-	40	70	μs	System-level overhead time excluded <sup>*1</sup>	Page mode write time(Program)	-	320	600	μs	System-level overhead time excluded <sup>*1</sup>	32bit write time(Work)	-	30	60	μs	System-level overhead time excluded <sup>*1</sup>
Parameter	Rating			Unit	Remarks																																																										
	Min	Typ	Max <sup>*3</sup>																																																												
Sector erase time	-	120	180	ms	Large sector <sup>*1</sup> Internal preprogramming time included																																																										
	-	120	180	ms	8kB sector <sup>*1</sup> Internal preprogramming time included																																																										
	-	120	180	ms	4kB sector <sup>*1</sup> Internal preprogramming time included																																																										
16bit write time(Program)	-	30	60	μs	System-level overhead time excluded <sup>*1</sup>																																																										
32bit write time(Program)	-	30	60	μs	System-level overhead time excluded <sup>*1</sup>																																																										
64bit write time(Program)	-	30	60	μs	System-level overhead time excluded <sup>*1</sup>																																																										
256bit write time(Program)	-	40	70	μs	System-level overhead time excluded <sup>*1</sup>																																																										
Page mode write time(Program)	-	320	600	μs	System-level overhead time excluded <sup>*1</sup>																																																										
32bit write time(Work)	-	30	60	μs	System-level overhead time excluded <sup>*1</sup>																																																										

Page	Section	Change Results								
270	12. Appendix 12.1 Application 1: JTAG tool connection	Error) - Correct) Newly added this section								
Rev. *F										
4	1. Overview 1.2 Document Definition	Error) Table 1-1  Correct) Table 1-1: Document Definition								
5	2. Function List 2.1 Function List	Error) Table 2-1  Correct) Table 2-1: Function Lineup								
7	2. Function List 2.2.1 Basic option	Error) Figure 2-1  Correct) Figure 2-1: Option and Part Number for S6J3310/20/30/40 Series								
7	2. Function List 2.2.1 Basic option	Error) Revision: Revision version  Correct) Revision: <table border="1" data-bbox="407 1192 1461 1360"> <thead> <tr> <th>Digit</th> <th>Description</th> </tr> </thead> <tbody> <tr> <td>C</td> <td>Fixed Operation frequency of embedded Program Flash and CPU, Fixed Stabilization time for sub oscillator</td> </tr> <tr> <td>D</td> <td>Fixed TCFLASH Sector Write Permission and Data Retention after Reset</td> </tr> <tr> <td>E</td> <td>Leakage current improvement</td> </tr> </tbody> </table>	Digit	Description	C	Fixed Operation frequency of embedded Program Flash and CPU, Fixed Stabilization time for sub oscillator	D	Fixed TCFLASH Sector Write Permission and Data Retention after Reset	E	Leakage current improvement
Digit	Description									
C	Fixed Operation frequency of embedded Program Flash and CPU, Fixed Stabilization time for sub oscillator									
D	Fixed TCFLASH Sector Write Permission and Data Retention after Reset									
E	Leakage current improvement									
8	2. Function List 2.2.3 Restriction	Error) Table 2-2  Correct) Table 2-2: Pin Restriction								
10	3. Product Description 3.2 Product Description	Error) Table 3-1  Correct) Table 3-1: Product Features								

Page	Section	Change Results
17	4. Package	Error)
18	and Pin	z : C, D (Revision)
19	Assignment	
20	4.1 Pin	Correct)
21	Assignment	z : C, D, <u>E</u> (Revision)
22		
23		
24		
25		
26		
27		
28		

Page	Section	Change Results																																																					
185	9. Electric Characteristics 9.1.3 DC characteristics	Error)																																																					
		<table border="1"> <thead> <tr> <th rowspan="2">Parameter</th> <th rowspan="2">Symbol</th> <th rowspan="2">Pin Name</th> <th rowspan="2">Conditions</th> <th colspan="3">Value</th> <th rowspan="2">Unit</th> <th rowspan="2">Remarks</th> </tr> <tr> <th>Min</th> <th>Typ</th> <th>Max</th> </tr> </thead> <tbody> <tr> <td rowspan="4">Power supply current</td> <td rowspan="3">I<sub>CC12</sub></td> <td rowspan="3">VCC1 2</td> <td rowspan="2">Normal operation</td> <td>-</td> <td>320</td> <td>800</td> <td rowspan="2">mA</td> <td>T<sub>A</sub> = -40 ~ 105°C CPU: 240MHz, HPM: 120MHz (CPU: 200MHz, HPM: 200MHz) GDC : 200MHz</td> </tr> <tr> <td>-</td> <td>-</td> <td>395</td> <td rowspan="2">mA</td> <td>Example use case *1 T<sub>A</sub> = -40 ~ 105°C CPU: 60MHz, HPM: 60MHz GDC : 60MHz</td> </tr> <tr> <td>Flash write/erase</td> <td>-</td> <td>350</td> <td>850</td> <td rowspan="2">mA</td> <td>T<sub>A</sub> = -40 ~ 105°C CPU: 240MHz, HPM: 120MHz (CPU: 200MHz, HPM: 200MHz) GDC : 200MHz</td> </tr> <tr> <td>I<sub>CCH12</sub></td> <td>Timer/ Stop Mode</td> <td>-</td> <td>-</td> <td>430</td> <td rowspan="2">mA</td> <td></td> </tr> <tr> <td rowspan="2">I<sub>CC5</sub></td> <td rowspan="2">VCC5</td> <td>Normal operation</td> <td>-</td> <td>45</td> <td>85</td> <td rowspan="2">mA</td> <td></td> </tr> <tr> <td>Flash write/erase</td> <td>-</td> <td>-</td> <td>100</td> <td rowspan="2">mA</td> <td></td> </tr> </tbody> </table>	Parameter	Symbol	Pin Name	Conditions	Value			Unit	Remarks	Min	Typ	Max	Power supply current	I <sub>CC12</sub>	VCC1 2	Normal operation	-	320	800	mA	T <sub>A</sub> = -40 ~ 105°C CPU: 240MHz, HPM: 120MHz (CPU: 200MHz, HPM: 200MHz) GDC : 200MHz	-	-	395	mA	Example use case *1 T <sub>A</sub> = -40 ~ 105°C CPU: 60MHz, HPM: 60MHz GDC : 60MHz	Flash write/erase	-	350	850	mA	T <sub>A</sub> = -40 ~ 105°C CPU: 240MHz, HPM: 120MHz (CPU: 200MHz, HPM: 200MHz) GDC : 200MHz	I <sub>CCH12</sub>	Timer/ Stop Mode	-	-	430	mA		I <sub>CC5</sub>	VCC5	Normal operation	-	45	85	mA		Flash write/erase	-	-	100	mA	
		Parameter					Symbol	Pin Name	Conditions			Value							Unit	Remarks																																			
			Min	Typ	Max																																																		
		Power supply current	I <sub>CC12</sub>	VCC1 2	Normal operation	-	320	800	mA	T <sub>A</sub> = -40 ~ 105°C CPU: 240MHz, HPM: 120MHz (CPU: 200MHz, HPM: 200MHz) GDC : 200MHz																																													
						-	-	395		mA	Example use case *1 T <sub>A</sub> = -40 ~ 105°C CPU: 60MHz, HPM: 60MHz GDC : 60MHz																																												
					Flash write/erase	-	350	850	mA		T <sub>A</sub> = -40 ~ 105°C CPU: 240MHz, HPM: 120MHz (CPU: 200MHz, HPM: 200MHz) GDC : 200MHz																																												
			I <sub>CCH12</sub>	Timer/ Stop Mode	-	-	430	mA																																															
		I <sub>CC5</sub>	VCC5	Normal operation	-	45	85		mA																																														
				Flash write/erase	-	-	100	mA																																															
		Correct)																																																					
		<table border="1"> <thead> <tr> <th rowspan="2">Parameter</th> <th rowspan="2">Symbol</th> <th rowspan="2">Pin Name</th> <th rowspan="2">Conditions</th> <th colspan="3">Value</th> <th rowspan="2">Unit</th> <th rowspan="2">Remarks</th> </tr> <tr> <th>Min</th> <th>Typ</th> <th>Max</th> </tr> </thead> <tbody> <tr> <td rowspan="6">Power supply current</td> <td rowspan="3">I<sub>CC12</sub></td> <td rowspan="3">VCC1 2</td> <td rowspan="2">Normal operation</td> <td>-</td> <td>315</td> <td>775</td> <td rowspan="2">mA</td> <td>T<sub>A</sub> = -40 ~ 105 °C CPU: 240 MHz, HPM: 120 MHz (CPU: 200 MHz, HPM: 200 MHz) GDC: 200 MHz</td> </tr> <tr> <td>-</td> <td>-</td> <td>395</td> <td rowspan="2">mA</td> <td>Example use case *1 T<sub>A</sub> = -40 ~ 105 °C CPU: 60 MHz, HPM: 60 MHz GDC : 60 MHz</td> </tr> <tr> <td>Flash write/erase</td> <td>-</td> <td>320</td> <td>780</td> <td rowspan="2">mA</td> <td>T<sub>A</sub> = -40 ~ 105°C CPU: 240 MHz, HPM: 120 MHz (CPU: 200 MHz, HPM: 200 MHz) GDC : 200 MHz</td> </tr> <tr> <td>I<sub>CCH12</sub></td> <td>Timer/ Stop Mode</td> <td>-</td> <td>-</td> <td>420</td> <td rowspan="2">mA</td> <td></td> </tr> <tr> <td rowspan="2">I<sub>CC5</sub></td> <td rowspan="2">VCC5</td> <td>Normal operation</td> <td>-</td> <td>25</td> <td>45</td> <td rowspan="2">mA</td> <td></td> </tr> <tr> <td>Flash write/erase</td> <td>-</td> <td>-</td> <td>60</td> <td rowspan="2">mA</td> <td></td> </tr> </tbody> </table>	Parameter	Symbol	Pin Name	Conditions	Value			Unit	Remarks	Min	Typ	Max	Power supply current	I <sub>CC12</sub>	VCC1 2	Normal operation	-	315	775	mA	T <sub>A</sub> = -40 ~ 105 °C CPU: 240 MHz, HPM: 120 MHz (CPU: 200 MHz, HPM: 200 MHz) GDC: 200 MHz	-	-	395	mA	Example use case *1 T <sub>A</sub> = -40 ~ 105 °C CPU: 60 MHz, HPM: 60 MHz GDC : 60 MHz	Flash write/erase	-	320	780	mA	T <sub>A</sub> = -40 ~ 105°C CPU: 240 MHz, HPM: 120 MHz (CPU: 200 MHz, HPM: 200 MHz) GDC : 200 MHz	I <sub>CCH12</sub>	Timer/ Stop Mode	-	-	420	mA		I <sub>CC5</sub>	VCC5	Normal operation	-	25	45	mA		Flash write/erase	-	-	60	mA	
		Parameter					Symbol	Pin Name	Conditions			Value							Unit	Remarks																																			
			Min	Typ	Max																																																		
		Power supply current	I <sub>CC12</sub>	VCC1 2	Normal operation	-	315	775	mA	T <sub>A</sub> = -40 ~ 105 °C CPU: 240 MHz, HPM: 120 MHz (CPU: 200 MHz, HPM: 200 MHz) GDC: 200 MHz																																													
						-	-	395		mA	Example use case *1 T <sub>A</sub> = -40 ~ 105 °C CPU: 60 MHz, HPM: 60 MHz GDC : 60 MHz																																												
					Flash write/erase	-	320	780	mA		T <sub>A</sub> = -40 ~ 105°C CPU: 240 MHz, HPM: 120 MHz (CPU: 200 MHz, HPM: 200 MHz) GDC : 200 MHz																																												
			I <sub>CCH12</sub>	Timer/ Stop Mode	-	-	420	mA																																															
			I <sub>CC5</sub>	VCC5	Normal operation	-	25		45	mA																																													
					Flash write/erase	-	-	60	mA																																														

Page	Section	Change Results													
187	9. Electric Characteristics 9.1.3 DC characteristics	Error) - Correct)													
			<b>Parameter</b>	<b>Symbol</b>	<b>Pin Name</b>	<b>Conditions</b>	<b>Value</b>			<b>Unit</b>	<b>Remarks</b>				
							<b>Min</b>	<b>Typ</b>	<b>Max</b>						
			Power supply current *	I <sub>CC15</sub>	VCC5	Timer mode	-	345	630	μA	T <sub>A</sub> =25 °C. 4 MHz crystal for main oscillator. PD1=ON, PD4_0=ON, PD4_1=ON				
											-	340	625	μA	T <sub>A</sub> =25 °C. 4 MHz crystal for main oscillator. PD1=ON, PD4_0=ON or PD4_1=ON
											-	335	620	μA	T <sub>A</sub> =25 °C. 4 MHz crystal for main oscillator. PD1=ON
											-	420	705	μA	T <sub>A</sub> =25 °C. 8 MHz crystal for main oscillator. PD1=ON, PD4_0=ON, PD4_1=ON
											-	415	700	μA	T <sub>A</sub> =25 °C. 8 MHz crystal for main oscillator. PD1=ON, PD4_0=ON or PD4_1=ON
											-	410	695	μA	T <sub>A</sub> =25 °C. 8 MHz crystal for main oscillator. PD1=ON
											-	80	135	μA	T <sub>A</sub> =25 °C. 32 kHz crystal for sub oscillator. PD1=ON, PD4_0=ON, PD4_1=ON
											-	75	130	μA	T <sub>A</sub> =25 °C. 32 kHz crystal for sub oscillator. PD1=ON, PD4_0=ON or PD4_1=ON
									-	70	125	μA	T <sub>A</sub> =25 °C. 32 kHz crystal for sub oscillator. PD1=ON		
						I <sub>CC15</sub>		Stop mode	-	75	130	μA	T <sub>A</sub> =25 °C. PD1=ON, PD4_0=ON, PD4_1=ON		
										-	70	125	μA	T <sub>A</sub> =25 °C. PD1=ON, PD4_0=ON or PD4_1=ON	
										-	65	120	μA	T <sub>A</sub> =25 °C. PD1=ON	

\* Electric Characteristics for S6J33xxxxE.

Page	Section	Change Results																																								
264 265	9. Electric Characteristics 9.1.6 Audio DAC	Error) Figure 9-1 Figure 9-2 Figure 9-3  Correct) Figure 9-1: Connection between R <sub>L</sub> and AVCC_DAC/2 (Example) Figure 9-2: Startup Time Figure 9-3: Coupling Capacitance (Example)																																								
270	11. Ordering Information	Error) x : C,D (Revision)  Correct) x : C,D, E (Revision)																																								
Rev. *G																																										
6	2. Function List 2.1. Function List	Function: CRC Error) 1 unit  Correct) 4 units																																								
6	2. Function List 2.1. Function List	Function: DDR HSSPI Error) 2 ch  Correct) 1 ch																																								
8	2. Function List 2.2.2 ID	Error) <table border="1" data-bbox="418 1255 1198 1524"> <thead> <tr> <th>Function Digit</th> <th>Revision</th> <th>Chip ID</th> <th>JTAG ID</th> </tr> </thead> <tbody> <tr> <td rowspan="2">S,U,T,V</td> <td>C</td> <td>0x10122100</td> <td rowspan="6">0x1000B5CF</td> </tr> <tr> <td>D</td> <td>0x10122200</td> </tr> <tr> <td rowspan="2">A,C,E,G</td> <td>C</td> <td>0x10128100</td> </tr> <tr> <td>D</td> <td>0x10128200</td> </tr> <tr> <td rowspan="2">B,D,F,H</td> <td>C</td> <td>0x10120100</td> </tr> <tr> <td>D</td> <td>0x10120200</td> </tr> </tbody> </table> Correct) <table border="1" data-bbox="418 1591 1198 1856"> <thead> <tr> <th>Function Digit</th> <th>Revision</th> <th>Chip ID</th> <th>JTAG ID</th> </tr> </thead> <tbody> <tr> <td rowspan="2">S,U,T,V</td> <td>C</td> <td>0x10122100</td> <td rowspan="6">0x1000B5CF</td> </tr> <tr> <td>D, E</td> <td>0x10122200</td> </tr> <tr> <td rowspan="2">A,C,E,G</td> <td>C</td> <td>0x10128100</td> </tr> <tr> <td>D, E</td> <td>0x10128200</td> </tr> <tr> <td rowspan="2">B,D,F,H</td> <td>C</td> <td>0x10120100</td> </tr> <tr> <td>D, E</td> <td>0x10120200</td> </tr> </tbody> </table>	Function Digit	Revision	Chip ID	JTAG ID	S,U,T,V	C	0x10122100	0x1000B5CF	D	0x10122200	A,C,E,G	C	0x10128100	D	0x10128200	B,D,F,H	C	0x10120100	D	0x10120200	Function Digit	Revision	Chip ID	JTAG ID	S,U,T,V	C	0x10122100	0x1000B5CF	D, E	0x10122200	A,C,E,G	C	0x10128100	D, E	0x10128200	B,D,F,H	C	0x10120100	D, E	0x10120200
Function Digit	Revision	Chip ID	JTAG ID																																							
S,U,T,V	C	0x10122100	0x1000B5CF																																							
	D	0x10122200																																								
A,C,E,G	C	0x10128100																																								
	D	0x10128200																																								
B,D,F,H	C	0x10120100																																								
	D	0x10120200																																								
Function Digit	Revision	Chip ID	JTAG ID																																							
S,U,T,V	C	0x10122100	0x1000B5CF																																							
	D, E	0x10122200																																								
A,C,E,G	C	0x10128100																																								
	D, E	0x10128200																																								
B,D,F,H	C	0x10120100																																								
	D, E	0x10120200																																								

Page	Section	Change Results
10	3: Product Description 3.2. Product Description	<p>Feature: Clock Error)</p> <p>-</p> <p>Correct)</p> <p>Main Oscillation Stabilization Wait Time (at 4 MHz):8.19ms (Initial value)</p>
10	3: Product Description 3.2. Product Description	<p>Error)</p> <p>-</p> <p>Correct)</p> <p>Feature: Embedded CR oscillation</p> <p>See the Traveo™ Platform hardware manual in detail.</p> <p>Stabilization time is as followings.</p> <ul style="list-style-type: none"> <li>- 0.35 ms to 0.8 ms for 4 MHz (Fast clock)</li> <li>- 0.43 ms to 1.28 ms for 100 kHz (Slow clock)</li> </ul>
11	3: Product Description 3.2. Product Description	<p>Feature: Reset Error)</p> <p>Based on Cortex R5F platform</p> <p>Following resets are not mounted on this device.</p> <ul style="list-style-type: none"> <li>- INITX</li> <li>- SRSTX</li> </ul> <p>Correct)</p> <p>RSTX pin + MD pin simultaneous assert INITX (Same as INITX pin input)</p> <ul style="list-style-type: none"> <li>- Occurrence factor: Simultaneously inputting "L" level to RSTX pin and inputting "L" level to MD pin</li> <li>- Release factor: Inputting "H" level to RSTX pin</li> </ul> <p>See the Traveo™ Platform hardware manual in detail.</p> <p>Following resets are not mounted on this device.</p> <ul style="list-style-type: none"> <li>- SRSTX (and nSRST pin)</li> </ul> <p>The product series does not support EX5VRST and writing EX5VRSTCNT bits in SYSC0_SPECIFGR has no effect.</p>
11	3: Product Description 3.2. Product Description	<p>Feature: PLL / SSCG PLL Error)</p> <p>Down spread mode is only supported and available.</p> <p>Correct)</p> <p>Product supports down spread and center spread modes with the conditions defined in 9.1.4.3 "Internal Clock Timing".</p>
12	3: Product Description 3.2. Product Description	<p>Feature: Embedded Program/Work Flash Memory Error)</p> <p>Work Flash can be accessed with 0-wait-cycle if CPU frequency is 12.5MHz or less.</p> <p>7-wait-cycle: 80MHz or less.</p> <p>13-wait-cycle: 160MHz or less.</p> <p>Correct)</p> <p>Work Flash can be accessed with 0-wait-cycle if CPU frequency is 12.5MHz or less.</p> <p>6-wait-cycle: 80MHz or less.</p> <p>12-wait-cycle: 160MHz or less.</p>

Page	Section	Change Results
13	3: Product Description 3.2. Product Description	<p>Feature: I2S Error)</p> <p>- I2S has its own PPU, but the function is fixed to disable.</p> <p>Correct)</p>
14	3: Product Description 3.2. Product Description	<p>Feature: Multi-Functional Serial (MFS) Error)</p> <p>Some ports of MFS have the dedicated I/O for I<sup>2</sup>C. See Port description list in detail.</p> <p>When the voltage supply of I<sup>2</sup>C interface is 5.0 V, it cannot use the I/O cells of 3.3 V voltage supply for the I<sup>2</sup>C terminal.</p> <p>CTS/RTS is not mounted (hardware flow control is not supported for this series.)</p> <p>Correct)</p> <p>Only 2 ports of MFS have the dedicated I/O for I<sup>2</sup>C. See I<sup>2</sup>C timing in 9.1.4.6 Multi-Function Serial in detail.</p> <p>The I<sup>2</sup>C is not designed to be hot swappable.</p> <p>CTS/RTS is not mounted (hardware flow control is not supported for this series.)</p>
14	3: Product Description 3.2. Product Description	<p>Feature: Hyper BUS I/F Error)</p> <p>The following register is not supported and cannot be used.</p> <ul style="list-style-type: none"> <li>- Controller Status Register (HYPERBUSIn_CSR)</li> <li>- Interrupt Status Register (HYPERBUSIn_ISR)</li> <li>- Write Protection Register (HYPERBUSIn_WPR)</li> <li>- Test Register (HYPERBUSIn_TEST)</li> </ul> <p>Correct)</p> <p>The following register is not supported and cannot be used.</p> <ul style="list-style-type: none"> <li>- Controller Status Register (HYPERBUSIn_CSR)</li> <li>- Interrupt Enable Register (HYPERBUSIn_IEN)</li> <li>- Interrupt Status Register (HYPERBUSIn_ISR)</li> <li>- Write Protection Register (HYPERBUSIn_WPR)</li> <li>- Test Register (HYPERBUSIn_TEST)</li> </ul>



Page	Section	Change Results																																																																																																																																																		
266	9. Electric Characteristics 9.1.7.1 Electrical Characteristics	<p>Error)</p> <table border="1"> <thead> <tr> <th rowspan="2">Parameter</th> <th colspan="3">Rating</th> <th rowspan="2">Unit</th> <th rowspan="2">Remarks</th> </tr> <tr> <th>Min</th> <th>Typ</th> <th>Max<sup>*3</sup></th> </tr> </thead> <tbody> <tr> <td rowspan="3">Sector erase time</td> <td>-</td> <td>120</td> <td>180</td> <td>ms</td> <td>Large sector*1 Internal preprogramming time included</td> </tr> <tr> <td>-</td> <td>120</td> <td>180</td> <td>ms</td> <td>8kB sector*1 Internal preprogramming time included</td> </tr> <tr> <td>-</td> <td>120</td> <td>180</td> <td>ms</td> <td>4kB sector*1 Internal preprogramming time included</td> </tr> <tr> <td>16bit write time(Program)</td> <td>-</td> <td>30</td> <td>60</td> <td>μs</td> <td>System-level overhead time excluded<sup>*1</sup></td> </tr> <tr> <td>32bit write time(Program)</td> <td>-</td> <td>30</td> <td>60</td> <td>μs</td> <td>System-level overhead time excluded<sup>*1</sup></td> </tr> <tr> <td>64bit write time(Program)</td> <td>-</td> <td>30</td> <td>60</td> <td>μs</td> <td>System-level overhead time excluded<sup>*1</sup></td> </tr> <tr> <td>256bit write time(Program)</td> <td>-</td> <td>40</td> <td>70</td> <td>μs</td> <td>System-level overhead time excluded<sup>*1</sup></td> </tr> <tr> <td>Page mode write time(Program)</td> <td>-</td> <td>320</td> <td>600</td> <td>μs</td> <td>System-level overhead time excluded<sup>*1</sup></td> </tr> <tr> <td>32bit write time(Work)</td> <td>-</td> <td>30</td> <td>60</td> <td>μs</td> <td>System-level overhead time excluded<sup>*1</sup></td> </tr> <tr> <td>Erase count / Data retention time(Program)<sup>*3</sup></td> <td>1,000/20 years</td> <td>-</td> <td>-</td> <td>-</td> <td>Temperature at write/erase time Average temperature T<sub>A</sub>=+85 degrees Celsius</td> </tr> <tr> <td>Erase count / Data retention time(Work)<sup>*3</sup></td> <td>1,000/20 years 10,000/10 years 100,000/5 years</td> <td>-</td> <td>-</td> <td>-</td> <td>Temperature at write/erase time Average temperature T<sub>A</sub>=+85 degrees Celsius</td> </tr> </tbody> </table> <p>*1: Guaranteed value for up to 1,000 erases *2: Guaranteed value for up to 100,000 erases *3: Target Value</p> <p>Correct)</p> <table border="1"> <thead> <tr> <th rowspan="2">Parameter</th> <th colspan="3">Rating</th> <th rowspan="2">Unit</th> <th rowspan="2">Remarks</th> </tr> <tr> <th>Min</th> <th>Typ</th> <th>Max</th> </tr> </thead> <tbody> <tr> <td rowspan="3">Sector erase time</td> <td>-</td> <td>120</td> <td>180</td> <td>ms</td> <td>Large sector*1 Internal preprogramming time included</td> </tr> <tr> <td>-</td> <td>120</td> <td>180</td> <td>ms</td> <td>8 kB sector*1 Internal preprogramming time included</td> </tr> <tr> <td>-</td> <td>120</td> <td>180</td> <td>ms</td> <td>4 kB sector*2 Internal preprogramming time included</td> </tr> <tr> <td>16-bit write time (Program)</td> <td>-</td> <td>30</td> <td>60</td> <td>μs</td> <td>System-level overhead time excluded<sup>*1</sup></td> </tr> <tr> <td>32-bit write time (Program)</td> <td>-</td> <td>30</td> <td>60</td> <td>μs</td> <td>System-level overhead time excluded<sup>*1</sup></td> </tr> <tr> <td>64-bit write time (Program)</td> <td>-</td> <td>30</td> <td>60</td> <td>μs</td> <td>System-level overhead time excluded<sup>*1</sup></td> </tr> <tr> <td>256-bit write time (Program)</td> <td>-</td> <td>40</td> <td>70</td> <td>μs</td> <td>System-level overhead time excluded<sup>*1</sup></td> </tr> <tr> <td>Page mode write time (Program)</td> <td>-</td> <td>320</td> <td>600</td> <td>μs</td> <td>System-level overhead time excluded<sup>*1</sup></td> </tr> <tr> <td>32-bit write time (Work)</td> <td>-</td> <td>30</td> <td>60</td> <td>μs</td> <td>System-level overhead time excluded<sup>*2</sup></td> </tr> <tr> <td>Erase count / Data retention time (Program)</td> <td>1,000/20 years</td> <td>-</td> <td>-</td> <td>-</td> <td>Temperature at write/erase time Average temperature T<sub>A</sub> = +85 degrees Celsius</td> </tr> <tr> <td>Erase count / Data retention time (Work)</td> <td>1,000/20 years 10,000/10 years 100,000/5 years</td> <td>-</td> <td>-</td> <td>-</td> <td>Temperature at write/erase time Average temperature T<sub>A</sub> = +85 degrees Celsius</td> </tr> </tbody> </table> <p>*1: Guaranteed value for up to 1,000 erases *2: Guaranteed value for up to 100,000 erases</p>	Parameter	Rating			Unit	Remarks	Min	Typ	Max <sup>*3</sup>	Sector erase time	-	120	180	ms	Large sector*1 Internal preprogramming time included	-	120	180	ms	8kB sector*1 Internal preprogramming time included	-	120	180	ms	4kB sector*1 Internal preprogramming time included	16bit write time(Program)	-	30	60	μs	System-level overhead time excluded <sup>*1</sup>	32bit write time(Program)	-	30	60	μs	System-level overhead time excluded <sup>*1</sup>	64bit write time(Program)	-	30	60	μs	System-level overhead time excluded <sup>*1</sup>	256bit write time(Program)	-	40	70	μs	System-level overhead time excluded <sup>*1</sup>	Page mode write time(Program)	-	320	600	μs	System-level overhead time excluded <sup>*1</sup>	32bit write time(Work)	-	30	60	μs	System-level overhead time excluded <sup>*1</sup>	Erase count / Data retention time(Program) <sup>*3</sup>	1,000/20 years	-	-	-	Temperature at write/erase time Average temperature T <sub>A</sub> =+85 degrees Celsius	Erase count / Data retention time(Work) <sup>*3</sup>	1,000/20 years 10,000/10 years 100,000/5 years	-	-	-	Temperature at write/erase time Average temperature T <sub>A</sub> =+85 degrees Celsius	Parameter	Rating			Unit	Remarks	Min	Typ	Max	Sector erase time	-	120	180	ms	Large sector*1 Internal preprogramming time included	-	120	180	ms	8 kB sector*1 Internal preprogramming time included	-	120	180	ms	4 kB sector*2 Internal preprogramming time included	16-bit write time (Program)	-	30	60	μs	System-level overhead time excluded <sup>*1</sup>	32-bit write time (Program)	-	30	60	μs	System-level overhead time excluded <sup>*1</sup>	64-bit write time (Program)	-	30	60	μs	System-level overhead time excluded <sup>*1</sup>	256-bit write time (Program)	-	40	70	μs	System-level overhead time excluded <sup>*1</sup>	Page mode write time (Program)	-	320	600	μs	System-level overhead time excluded <sup>*1</sup>	32-bit write time (Work)	-	30	60	μs	System-level overhead time excluded <sup>*2</sup>	Erase count / Data retention time (Program)	1,000/20 years	-	-	-	Temperature at write/erase time Average temperature T <sub>A</sub> = +85 degrees Celsius	Erase count / Data retention time (Work)	1,000/20 years 10,000/10 years 100,000/5 years	-	-	-	Temperature at write/erase time Average temperature T <sub>A</sub> = +85 degrees Celsius
Parameter	Rating			Unit	Remarks																																																																																																																																															
	Min	Typ	Max <sup>*3</sup>																																																																																																																																																	
Sector erase time	-	120	180	ms	Large sector*1 Internal preprogramming time included																																																																																																																																															
	-	120	180	ms	8kB sector*1 Internal preprogramming time included																																																																																																																																															
	-	120	180	ms	4kB sector*1 Internal preprogramming time included																																																																																																																																															
16bit write time(Program)	-	30	60	μs	System-level overhead time excluded <sup>*1</sup>																																																																																																																																															
32bit write time(Program)	-	30	60	μs	System-level overhead time excluded <sup>*1</sup>																																																																																																																																															
64bit write time(Program)	-	30	60	μs	System-level overhead time excluded <sup>*1</sup>																																																																																																																																															
256bit write time(Program)	-	40	70	μs	System-level overhead time excluded <sup>*1</sup>																																																																																																																																															
Page mode write time(Program)	-	320	600	μs	System-level overhead time excluded <sup>*1</sup>																																																																																																																																															
32bit write time(Work)	-	30	60	μs	System-level overhead time excluded <sup>*1</sup>																																																																																																																																															
Erase count / Data retention time(Program) <sup>*3</sup>	1,000/20 years	-	-	-	Temperature at write/erase time Average temperature T <sub>A</sub> =+85 degrees Celsius																																																																																																																																															
Erase count / Data retention time(Work) <sup>*3</sup>	1,000/20 years 10,000/10 years 100,000/5 years	-	-	-	Temperature at write/erase time Average temperature T <sub>A</sub> =+85 degrees Celsius																																																																																																																																															
Parameter	Rating			Unit	Remarks																																																																																																																																															
	Min	Typ	Max																																																																																																																																																	
Sector erase time	-	120	180	ms	Large sector*1 Internal preprogramming time included																																																																																																																																															
	-	120	180	ms	8 kB sector*1 Internal preprogramming time included																																																																																																																																															
	-	120	180	ms	4 kB sector*2 Internal preprogramming time included																																																																																																																																															
16-bit write time (Program)	-	30	60	μs	System-level overhead time excluded <sup>*1</sup>																																																																																																																																															
32-bit write time (Program)	-	30	60	μs	System-level overhead time excluded <sup>*1</sup>																																																																																																																																															
64-bit write time (Program)	-	30	60	μs	System-level overhead time excluded <sup>*1</sup>																																																																																																																																															
256-bit write time (Program)	-	40	70	μs	System-level overhead time excluded <sup>*1</sup>																																																																																																																																															
Page mode write time (Program)	-	320	600	μs	System-level overhead time excluded <sup>*1</sup>																																																																																																																																															
32-bit write time (Work)	-	30	60	μs	System-level overhead time excluded <sup>*2</sup>																																																																																																																																															
Erase count / Data retention time (Program)	1,000/20 years	-	-	-	Temperature at write/erase time Average temperature T <sub>A</sub> = +85 degrees Celsius																																																																																																																																															
Erase count / Data retention time (Work)	1,000/20 years 10,000/10 years 100,000/5 years	-	-	-	Temperature at write/erase time Average temperature T <sub>A</sub> = +85 degrees Celsius																																																																																																																																															

Page	Section	Change Results																
Rev. *H																		
4	1. Overview 1.2 Document Definition	Added the Document Definition as below.																
		Error																
		<table border="1"> <thead> <tr> <th>Document Type</th> <th>Definition</th> <th>Primary User</th> <th>Document Code</th> </tr> </thead> <tbody> <tr> <td>S6J3310/20/30/40 Datasheet</td> <td>The function and its characteristics are specified quantitatively.</td> <td>Investigator and hardware engineer</td> <td>002-10635</td> </tr> <tr> <td>S6J3300 Hardware Manual</td> <td>The function and its operation of S6J3300 series are described.</td> <td>Software engineer</td> <td>002-10185</td> </tr> <tr> <td>Traveo™ Platform Hardware Manual</td> <td>The function and its operation of CPU core platform are described.</td> <td>Software engineer</td> <td>002-07884</td> </tr> </tbody> </table>	Document Type	Definition	Primary User	Document Code	S6J3310/20/30/40 Datasheet	The function and its characteristics are specified quantitatively.	Investigator and hardware engineer	002-10635	S6J3300 Hardware Manual	The function and its operation of S6J3300 series are described.	Software engineer	002-10185	Traveo™ Platform Hardware Manual	The function and its operation of CPU core platform are described.	Software engineer	002-07884
		Document Type	Definition	Primary User	Document Code													
		S6J3310/20/30/40 Datasheet	The function and its characteristics are specified quantitatively.	Investigator and hardware engineer	002-10635													
		S6J3300 Hardware Manual	The function and its operation of S6J3300 series are described.	Software engineer	002-10185													
		Traveo™ Platform Hardware Manual	The function and its operation of CPU core platform are described.	Software engineer	002-07884													
		Correct																
		<table border="1"> <thead> <tr> <th>Document Type</th> <th>Definition</th> <th>Primary User</th> <th>Document Code</th> </tr> </thead> <tbody> <tr> <td>S6J3310/20/30/40 Datasheet</td> <td>This document. The function and its characteristics are specified quantitatively.</td> <td>Investigator and hardware engineer</td> <td>002-10635</td> </tr> <tr> <td>S6J3300 Hardware Manual</td> <td>S6J3300 Series 32-bit Microcontroller Traveo™ Family Hardware Manual The function and its operation of S6J3300 series are described.</td> <td>Software engineer</td> <td>002-10185</td> </tr> <tr> <td>Traveo™ Platform Hardware Manual</td> <td>32-Bit Microcontroller Traveo™ Family S6J33xx, S6J34xx, S6J35xx Series Hardware Manual Platform Part The function and its operation of CPU core platform are described.</td> <td>Software engineer</td> <td>002-07884</td> </tr> </tbody> </table>	Document Type	Definition	Primary User	Document Code	S6J3310/20/30/40 Datasheet	This document. The function and its characteristics are specified quantitatively.	Investigator and hardware engineer	002-10635	S6J3300 Hardware Manual	S6J3300 Series 32-bit Microcontroller Traveo™ Family Hardware Manual The function and its operation of S6J3300 series are described.	Software engineer	002-10185	Traveo™ Platform Hardware Manual	32-Bit Microcontroller Traveo™ Family S6J33xx, S6J34xx, S6J35xx Series Hardware Manual Platform Part The function and its operation of CPU core platform are described.	Software engineer	002-07884
		Document Type	Definition	Primary User	Document Code													
S6J3310/20/30/40 Datasheet	This document. The function and its characteristics are specified quantitatively.	Investigator and hardware engineer	002-10635															
S6J3300 Hardware Manual	S6J3300 Series 32-bit Microcontroller Traveo™ Family Hardware Manual The function and its operation of S6J3300 series are described.	Software engineer	002-10185															
Traveo™ Platform Hardware Manual	32-Bit Microcontroller Traveo™ Family S6J33xx, S6J34xx, S6J35xx Series Hardware Manual Platform Part The function and its operation of CPU core platform are described.	Software engineer	002-07884															
Deleted as below.																		
-Note: The description of the preliminary documentation will be changed without any notification.																		
14	3: Product Description 3.2. Product Description																	

Page	Section	Change Results						
175	9. Electric Characteristics 9.1.3 DC Characteristics	Added the Hysteresis voltage as below. Correct)						
	Hysteresis voltage	V <sub>HYS1</sub>	P0_00 to P0_20, P2_09 to	CMOS hysteresis input level is selected	-	0.05×V <sub>CC53</sub>	-	V
		V <sub>HYS2</sub>	P2_19, P3_00 to P3_07, P3_24 to	Automotive input level is selected	-	0.03×V <sub>CC53</sub>	-	V
		V <sub>HYS3</sub>	P3_31, P4_00 to P4_07	TTL input level is selected	-	0.035	-	V
		V <sub>HYS4</sub>	P1_03 to P1_16, P3_08 to P3_23, P4_08 to	CMOS hysteresis input level is selected	-	0.05×V <sub>CC5</sub>	-	V
		V <sub>HYS5</sub>	P4_23	Automotive input level is selected	-	0.03×V <sub>CC5</sub>	-	V
		V <sub>HYS6</sub>	P1_09, P1_10, P1_15, P1_16	TTL input level is selected	-	0.035	-	V
		V <sub>HYS7</sub>	P1_17 to P1_31, P2_00 to P2_08, P4_24 to	CMOS hysteresis input level is selected	-	0.05×DV <sub>CC</sub>	-	V
		V <sub>HYS8</sub>	P4_31	Automotive input level is selected	-	0.03×DV <sub>CC</sub>	-	V
		V <sub>HYS9</sub>	RSTX NMIX	-	-	0.05×V <sub>CC5</sub>	-	V
		V <sub>HYS10</sub>	MD	-	-	0.05×V <sub>CC5</sub>	-	V
		V <sub>HYS11</sub>	JTAG_NTRST JTAG_TCK JTAG_TDI JTAG_TMS	-	-	0.035	-	V
		V <sub>HYS12</sub>	P0_21 to P0_31, P1_00 to P1_02	CMOS hysteresis input level is selected	-	0.05×V <sub>CC3</sub>	-	V
		V <sub>HYS13</sub>	P0_21 to P0_31	TTL input level is selected	-	0.035	-	V
		V <sub>HYS14</sub>	P1_00 to P1_02	-	-	0.080	-	V MediaL B

Page	Section	Change Results
187	9. Electric Characteristics 9.1.4.3 Internal Clock Timing	Added the *4 in "Remarks" column  Error) SSCG0 output clock SSCG1 output clock SSCG2 output clock SSCG3 output clock PLL0 output clock PLL1 output clock PLL2 output clock PLL3 output clock  Correct) SSCG0 output clock *4 SSCG1 output clock *4 SSCG2 output clock *4 SSCG3 output clock *4 PLL0 output clock *4 PLL1 output clock *4 PLL2 output clock *4 PLL3 output clock *4
188	9. Electric Characteristics 9.1.4.3 Internal Clock Timing	Added the below *4 sentence.  Error) (none)  Correct) *4: The PLLx/SSCGx cannot set under 200MHz.
195, 198, 201, 204, 207, 210, 213, 216, 249	9. Electric Characteristics 9.1.4 AC Characteristics	Modified the shading document name as below.  Error) <i>For details, see the hardware manual.</i>  Correct) <i>For details, see the <u>Traveo™ Platform Hardware Manual</u>.</i>
227	9. Electric Characteristics 9.1.4 AC Characteristics	Modified the shading document name as below.  Error) <i>Please refer to <u>Product Hardware Manual</u> for available list.</i>  Correct) <i>Please refer to <u>S6J3300 series Hardware Manual</u> for available list.</i>

Page	Section	Change Results																																		
265	11. Ordering Information	<p>Revised as below.</p> <p>Error)</p> <table border="1"> <thead> <tr> <th>Part Number *1</th> <th>Package</th> </tr> </thead> <tbody> <tr> <td>S6J331EKEx*****</td> <td>208-pin plastic TEQFP (LEW208)</td> </tr> <tr> <td>S6J332CKSx*****</td> <td>208-pin plastic TEQFP (LEW208)</td> </tr> <tr> <td>S6J334CKSx*****</td> <td>208-pin plastic TEQFP (LEW208)</td> </tr> <tr> <td>S6J331EJAx*****</td> <td>176-pin plastic TEQFP (LEV176)</td> </tr> <tr> <td>S6J332CJBx*****</td> <td>176-pin plastic TEQFP (LEV176)</td> </tr> <tr> <td>S6J332CJT<sub>x</sub>*****</td> <td>176-pin plastic TEQFP (LEV176)</td> </tr> <tr> <td>S6J332EJBx*****</td> <td>176-pin plastic TEQFP (LEV176)</td> </tr> <tr> <td>S6J334BJD<sub>x</sub>*****</td> <td>176-pin plastic TEQFP (LEV176)</td> </tr> <tr> <td>S6J334CJEx*****</td> <td>176-pin plastic TEQFP (LEV176)</td> </tr> <tr> <td>S6J334CJT<sub>x</sub>*****</td> <td>176-pin plastic TEQFP (LEV176)</td> </tr> <tr> <td>S6J334DJEx*****</td> <td>176-pin plastic TEQFP (LEV176)</td> </tr> <tr> <td>S6J334DJT<sub>x</sub>*****</td> <td>176-pin plastic TEQFP (LEV176)</td> </tr> <tr> <td>S6J334EJAx*****</td> <td>176-pin plastic TEQFP (LEV176)</td> </tr> <tr> <td>S6J334EJEx*****</td> <td>176-pin plastic TEQFP (LEV176)</td> </tr> <tr> <td>S6J334EJT<sub>x</sub>*****</td> <td>176-pin plastic TEQFP (LEV176)</td> </tr> <tr> <td>S6J334CHBx*****</td> <td>144-pin plastic TEQFP (LEX144, LEK144)</td> </tr> </tbody> </table>	Part Number *1	Package	S6J331EKEx*****	208-pin plastic TEQFP (LEW208)	S6J332CKSx*****	208-pin plastic TEQFP (LEW208)	S6J334CKSx*****	208-pin plastic TEQFP (LEW208)	S6J331EJAx*****	176-pin plastic TEQFP (LEV176)	S6J332CJBx*****	176-pin plastic TEQFP (LEV176)	S6J332CJT <sub>x</sub> *****	176-pin plastic TEQFP (LEV176)	S6J332EJBx*****	176-pin plastic TEQFP (LEV176)	S6J334BJD <sub>x</sub> *****	176-pin plastic TEQFP (LEV176)	S6J334CJEx*****	176-pin plastic TEQFP (LEV176)	S6J334CJT <sub>x</sub> *****	176-pin plastic TEQFP (LEV176)	S6J334DJEx*****	176-pin plastic TEQFP (LEV176)	S6J334DJT <sub>x</sub> *****	176-pin plastic TEQFP (LEV176)	S6J334EJAx*****	176-pin plastic TEQFP (LEV176)	S6J334EJEx*****	176-pin plastic TEQFP (LEV176)	S6J334EJT <sub>x</sub> *****	176-pin plastic TEQFP (LEV176)	S6J334CHBx*****	144-pin plastic TEQFP (LEX144, LEK144)
Part Number *1	Package																																			
S6J331EKEx*****	208-pin plastic TEQFP (LEW208)																																			
S6J332CKSx*****	208-pin plastic TEQFP (LEW208)																																			
S6J334CKSx*****	208-pin plastic TEQFP (LEW208)																																			
S6J331EJAx*****	176-pin plastic TEQFP (LEV176)																																			
S6J332CJBx*****	176-pin plastic TEQFP (LEV176)																																			
S6J332CJT <sub>x</sub> *****	176-pin plastic TEQFP (LEV176)																																			
S6J332EJBx*****	176-pin plastic TEQFP (LEV176)																																			
S6J334BJD <sub>x</sub> *****	176-pin plastic TEQFP (LEV176)																																			
S6J334CJEx*****	176-pin plastic TEQFP (LEV176)																																			
S6J334CJT <sub>x</sub> *****	176-pin plastic TEQFP (LEV176)																																			
S6J334DJEx*****	176-pin plastic TEQFP (LEV176)																																			
S6J334DJT <sub>x</sub> *****	176-pin plastic TEQFP (LEV176)																																			
S6J334EJAx*****	176-pin plastic TEQFP (LEV176)																																			
S6J334EJEx*****	176-pin plastic TEQFP (LEV176)																																			
S6J334EJT <sub>x</sub> *****	176-pin plastic TEQFP (LEV176)																																			
S6J334CHBx*****	144-pin plastic TEQFP (LEX144, LEK144)																																			

Page	Section	Change Results																																																						
265	11. Ordering Information	<p>Correct)</p> <table border="1"> <thead> <tr> <th>Part Number</th> <th>Package</th> </tr> </thead> <tbody> <tr><td>S6J331EKSESE20000</td><td>208-pin plastic TEQFP (LEW208)</td></tr> <tr><td>S6J332CKSDSE20000</td><td>208-pin plastic TEQFP (LEW208)</td></tr> <tr><td>S6J334CKSESE20000</td><td>208-pin plastic TEQFP (LEW208)</td></tr> <tr><td>S6J331EJSESE20000</td><td>176-pin plastic TEQFP (LEV176)</td></tr> <tr><td>S6J332EJBDSE20000</td><td>176-pin plastic TEQFP (LEV176)</td></tr> <tr><td>S6J332EJTDSE20000</td><td>176-pin plastic TEQFP (LEV176)</td></tr> <tr><td>S6J332EJBESE20000</td><td>176-pin plastic TEQFP (LEV176)</td></tr> <tr><td>S6J332EJTESE20000</td><td>176-pin plastic TEQFP (LEV176)</td></tr> <tr><td>S6J332DJEESE20000</td><td>176-pin plastic TEQFP (LEV176)</td></tr> <tr><td>S6J334BJDDSE20000</td><td>176-pin plastic TEQFP (LEV176)</td></tr> <tr><td>S6J334EJBESE20000</td><td>176-pin plastic TEQFP (LEV176)</td></tr> <tr><td>S6J334EJTESE20000</td><td>176-pin plastic TEQFP (LEV176)</td></tr> <tr><td>S6J334EJEESE20000</td><td>176-pin plastic TEQFP (LEV176)</td></tr> <tr><td>S6J334DJTESE20000</td><td>176-pin plastic TEQFP (LEV176)</td></tr> <tr><td>S6J334DJEESE20000</td><td>176-pin plastic TEQFP (LEV176)</td></tr> <tr><td>S6J334CJBESE20000</td><td>176-pin plastic TEQFP (LEV176)</td></tr> <tr><td>S6J334CJEESE20000</td><td>176-pin plastic TEQFP (LEV176)</td></tr> <tr><td>S6J334BJDESE20000</td><td>176-pin plastic TEQFP (LEV176)</td></tr> <tr><td>S6J334EJTCSE2000A</td><td>176-pin plastic TEQFP (LEV176)</td></tr> <tr><td>S6J334EJEDSE2000A</td><td>176-pin plastic TEQFP (LEV176)</td></tr> <tr><td>S6J332EHBESE20000</td><td>144-pin plastic TEQFP (LEX144, LEK144)</td></tr> <tr><td>S6J334EHEESE20000</td><td>144-pin plastic TEQFP (LEX144, LEK144)</td></tr> <tr><td>S6J334DHEESE20000</td><td>144-pin plastic TEQFP (LEX144, LEK144)</td></tr> <tr><td>S6J334DHFESE20000</td><td>144-pin plastic TEQFP (LEX144, LEK144)</td></tr> <tr><td>S6J334CHEESE20000</td><td>144-pin plastic TEQFP (LEX144, LEK144)</td></tr> <tr><td>S6J334CHFSE20000</td><td>144-pin plastic TEQFP (LEX144, LEK144)</td></tr> </tbody> </table>	Part Number	Package	S6J331EKSESE20000	208-pin plastic TEQFP (LEW208)	S6J332CKSDSE20000	208-pin plastic TEQFP (LEW208)	S6J334CKSESE20000	208-pin plastic TEQFP (LEW208)	S6J331EJSESE20000	176-pin plastic TEQFP (LEV176)	S6J332EJBDSE20000	176-pin plastic TEQFP (LEV176)	S6J332EJTDSE20000	176-pin plastic TEQFP (LEV176)	S6J332EJBESE20000	176-pin plastic TEQFP (LEV176)	S6J332EJTESE20000	176-pin plastic TEQFP (LEV176)	S6J332DJEESE20000	176-pin plastic TEQFP (LEV176)	S6J334BJDDSE20000	176-pin plastic TEQFP (LEV176)	S6J334EJBESE20000	176-pin plastic TEQFP (LEV176)	S6J334EJTESE20000	176-pin plastic TEQFP (LEV176)	S6J334EJEESE20000	176-pin plastic TEQFP (LEV176)	S6J334DJTESE20000	176-pin plastic TEQFP (LEV176)	S6J334DJEESE20000	176-pin plastic TEQFP (LEV176)	S6J334CJBESE20000	176-pin plastic TEQFP (LEV176)	S6J334CJEESE20000	176-pin plastic TEQFP (LEV176)	S6J334BJDESE20000	176-pin plastic TEQFP (LEV176)	S6J334EJTCSE2000A	176-pin plastic TEQFP (LEV176)	S6J334EJEDSE2000A	176-pin plastic TEQFP (LEV176)	S6J332EHBESE20000	144-pin plastic TEQFP (LEX144, LEK144)	S6J334EHEESE20000	144-pin plastic TEQFP (LEX144, LEK144)	S6J334DHEESE20000	144-pin plastic TEQFP (LEX144, LEK144)	S6J334DHFESE20000	144-pin plastic TEQFP (LEX144, LEK144)	S6J334CHEESE20000	144-pin plastic TEQFP (LEX144, LEK144)	S6J334CHFSE20000	144-pin plastic TEQFP (LEX144, LEK144)
Part Number	Package																																																							
S6J331EKSESE20000	208-pin plastic TEQFP (LEW208)																																																							
S6J332CKSDSE20000	208-pin plastic TEQFP (LEW208)																																																							
S6J334CKSESE20000	208-pin plastic TEQFP (LEW208)																																																							
S6J331EJSESE20000	176-pin plastic TEQFP (LEV176)																																																							
S6J332EJBDSE20000	176-pin plastic TEQFP (LEV176)																																																							
S6J332EJTDSE20000	176-pin plastic TEQFP (LEV176)																																																							
S6J332EJBESE20000	176-pin plastic TEQFP (LEV176)																																																							
S6J332EJTESE20000	176-pin plastic TEQFP (LEV176)																																																							
S6J332DJEESE20000	176-pin plastic TEQFP (LEV176)																																																							
S6J334BJDDSE20000	176-pin plastic TEQFP (LEV176)																																																							
S6J334EJBESE20000	176-pin plastic TEQFP (LEV176)																																																							
S6J334EJTESE20000	176-pin plastic TEQFP (LEV176)																																																							
S6J334EJEESE20000	176-pin plastic TEQFP (LEV176)																																																							
S6J334DJTESE20000	176-pin plastic TEQFP (LEV176)																																																							
S6J334DJEESE20000	176-pin plastic TEQFP (LEV176)																																																							
S6J334CJBESE20000	176-pin plastic TEQFP (LEV176)																																																							
S6J334CJEESE20000	176-pin plastic TEQFP (LEV176)																																																							
S6J334BJDESE20000	176-pin plastic TEQFP (LEV176)																																																							
S6J334EJTCSE2000A	176-pin plastic TEQFP (LEV176)																																																							
S6J334EJEDSE2000A	176-pin plastic TEQFP (LEV176)																																																							
S6J332EHBESE20000	144-pin plastic TEQFP (LEX144, LEK144)																																																							
S6J334EHEESE20000	144-pin plastic TEQFP (LEX144, LEK144)																																																							
S6J334DHEESE20000	144-pin plastic TEQFP (LEX144, LEK144)																																																							
S6J334DHFESE20000	144-pin plastic TEQFP (LEX144, LEK144)																																																							
S6J334CHEESE20000	144-pin plastic TEQFP (LEX144, LEK144)																																																							
S6J334CHFSE20000	144-pin plastic TEQFP (LEX144, LEK144)																																																							
Rev. *I																																																								

Page	Section	Change Results				
11	3. Product Description 3.2 Product Description Table 3-1: Product Features	<p>Added the below</p> <p>Correct)</p> <table border="1"> <thead> <tr> <th>Feature</th> <th>Description</th> </tr> </thead> <tbody> <tr> <td>A/D Converter</td> <td>AN39 to AN63 are not support for S6J33xxxAx, S6J33xxxCx, S6J33xxxEx, and S6J33xxxGx option.</td> </tr> </tbody> </table>	Feature	Description	A/D Converter	AN39 to AN63 are not support for S6J33xxxAx, S6J33xxxCx, S6J33xxxEx, and S6J33xxxGx option.
Feature	Description					
A/D Converter	AN39 to AN63 are not support for S6J33xxxAx, S6J33xxxCx, S6J33xxxEx, and S6J33xxxGx option.					

14	<p>CHAPTER 3: Product Description 3.2.1. Ethernet</p>	<p>Deleted the shading parts as below:</p> <p>Error)</p> <table border="1" data-bbox="407 369 1516 1423"> <thead> <tr> <th data-bbox="407 369 1344 405">Functions</th> <th data-bbox="1344 369 1516 405">Remark</th> </tr> </thead> <tbody> <tr> <td data-bbox="407 405 1344 548">           Direct Memory Access Interface.            - partial store and forward            - force max amba burst tx/rc            - Priority Queueing (Screening)         </td> <td data-bbox="1344 405 1516 548"></td> </tr> <tr> <td data-bbox="407 548 1344 583">External FIFO Interface</td> <td data-bbox="1344 548 1516 583"></td> </tr> <tr> <td data-bbox="407 583 1344 619">Additional Low Latency TX FIFO Interface for DMA configurations</td> <td data-bbox="1344 583 1516 619"></td> </tr> <tr> <td data-bbox="407 619 1344 762">           MAC Transmit Block            - half-duplex            - collision            - back_pressure         </td> <td data-bbox="1344 619 1516 762"></td> </tr> <tr> <td data-bbox="407 762 1344 898">           MAC Filtering Block            - external address match            - VLAN tag            - Wakeup On Lan         </td> <td data-bbox="1344 762 1516 898"></td> </tr> <tr> <td data-bbox="407 898 1344 934">IEEE 1588 and IEEE 802.1AS Support</td> <td data-bbox="1344 898 1516 934"></td> </tr> <tr> <td data-bbox="407 934 1344 970">MAC PFC Priority Based Pause Frame Support</td> <td data-bbox="1344 934 1516 970"></td> </tr> <tr> <td data-bbox="407 970 1344 1005">Energy Efficient Ethernet support</td> <td data-bbox="1344 970 1516 1005"></td> </tr> <tr> <td data-bbox="407 1005 1344 1041">LPI Operation in Cadence IP</td> <td data-bbox="1344 1005 1516 1041"></td> </tr> <tr> <td data-bbox="407 1041 1344 1077">802.1Qav Support – Credit Based Shaping</td> <td data-bbox="1344 1041 1516 1077"></td> </tr> <tr> <td data-bbox="407 1077 1344 1213">           PHY Interface            - GMII            - SGMII            - TBI         </td> <td data-bbox="1344 1077 1516 1213"></td> </tr> <tr> <td data-bbox="407 1213 1344 1318">           10/100/1000 Operation            - 10 M            - 1000 M         </td> <td data-bbox="1344 1213 1516 1318"></td> </tr> <tr> <td data-bbox="407 1318 1344 1354">SGMII Operation</td> <td data-bbox="1344 1318 1516 1354"></td> </tr> <tr> <td data-bbox="407 1354 1344 1390">Jumbo Frames</td> <td data-bbox="1344 1354 1516 1390"></td> </tr> <tr> <td data-bbox="407 1390 1344 1423">Physical Control Sub-Layer</td> <td data-bbox="1344 1390 1516 1423"></td> </tr> </tbody> </table> <p>Correct)</p> <table border="1" data-bbox="407 1493 1516 1950"> <thead> <tr> <th data-bbox="407 1493 1344 1528">Functions</th> <th data-bbox="1344 1493 1516 1528">Remark</th> </tr> </thead> <tbody> <tr> <td data-bbox="407 1528 1344 1564">External FIFO Interface</td> <td data-bbox="1344 1528 1516 1564"></td> </tr> <tr> <td data-bbox="407 1564 1344 1600">Additional Low Latency TX FIFO Interface for DMA configurations</td> <td data-bbox="1344 1564 1516 1600"></td> </tr> <tr> <td data-bbox="407 1600 1344 1743">           MAC Transmit Block            - half-duplex            - collision            - back_pressure         </td> <td data-bbox="1344 1600 1516 1743"></td> </tr> <tr> <td data-bbox="407 1743 1344 1848">           MAC Filtering Block            - external address match            - Wakeup On Lan         </td> <td data-bbox="1344 1743 1516 1848"></td> </tr> <tr> <td data-bbox="407 1848 1344 1883">Energy Efficient Ethernet support</td> <td data-bbox="1344 1848 1516 1883"></td> </tr> <tr> <td data-bbox="407 1883 1344 1919">LPI Operation in Cadence IP</td> <td data-bbox="1344 1883 1516 1919"></td> </tr> <tr> <td data-bbox="407 1919 1344 1950">PHY Interface</td> <td data-bbox="1344 1919 1516 1950"></td> </tr> </tbody> </table>	Functions	Remark	Direct Memory Access Interface. - partial store and forward - force max amba burst tx/rc - Priority Queueing (Screening)		External FIFO Interface		Additional Low Latency TX FIFO Interface for DMA configurations		MAC Transmit Block - half-duplex - collision - back_pressure		MAC Filtering Block - external address match - VLAN tag - Wakeup On Lan		IEEE 1588 and IEEE 802.1AS Support		MAC PFC Priority Based Pause Frame Support		Energy Efficient Ethernet support		LPI Operation in Cadence IP		802.1Qav Support – Credit Based Shaping		PHY Interface - GMII - SGMII - TBI		10/100/1000 Operation - 10 M - 1000 M		SGMII Operation		Jumbo Frames		Physical Control Sub-Layer		Functions	Remark	External FIFO Interface		Additional Low Latency TX FIFO Interface for DMA configurations		MAC Transmit Block - half-duplex - collision - back_pressure		MAC Filtering Block - external address match - Wakeup On Lan		Energy Efficient Ethernet support		LPI Operation in Cadence IP		PHY Interface	
Functions	Remark																																																	
Direct Memory Access Interface. - partial store and forward - force max amba burst tx/rc - Priority Queueing (Screening)																																																		
External FIFO Interface																																																		
Additional Low Latency TX FIFO Interface for DMA configurations																																																		
MAC Transmit Block - half-duplex - collision - back_pressure																																																		
MAC Filtering Block - external address match - VLAN tag - Wakeup On Lan																																																		
IEEE 1588 and IEEE 802.1AS Support																																																		
MAC PFC Priority Based Pause Frame Support																																																		
Energy Efficient Ethernet support																																																		
LPI Operation in Cadence IP																																																		
802.1Qav Support – Credit Based Shaping																																																		
PHY Interface - GMII - SGMII - TBI																																																		
10/100/1000 Operation - 10 M - 1000 M																																																		
SGMII Operation																																																		
Jumbo Frames																																																		
Physical Control Sub-Layer																																																		
Functions	Remark																																																	
External FIFO Interface																																																		
Additional Low Latency TX FIFO Interface for DMA configurations																																																		
MAC Transmit Block - half-duplex - collision - back_pressure																																																		
MAC Filtering Block - external address match - Wakeup On Lan																																																		
Energy Efficient Ethernet support																																																		
LPI Operation in Cadence IP																																																		
PHY Interface																																																		



Page	Section	Change Results					
		<ul style="list-style-type: none"> <li>- GMII</li> <li>- SGMII</li> <li>- TBI</li> </ul>					
		10/100/1000 Operation					
		- 1000 M					
		SGMII Operation					
		Jumbo Frames					
		Physical Control Sub-Layer					
46	6. Port Description 6.1 Port Description List Table 6-1 S6J3310 Series	Revised the below					
		Error)					
				Package Pin Number			Remark
		Port Name	Description	TEQFP 144	TEQFP 176	TEQFP 208	
		PPG0_TOUT0_1	Base timer 1 output pin (1)	8	8	11	
		Correct)					
				Package Pin Number			Remark
		Port Name	Description	TEQFP 144	TEQFP 176	TEQFP 208	
		PPG0_TOUT0_1	Base timer 0 output pin (1)	8	8	11	
47	6. Port Description 6.1 Port Description List Table 6-1 S6J3310 Series	Revised the below					
		Error)					
				Package Pin Number			Remark
		Port Name	Description	TEQFP 144	TEQFP 176	TEQFP 208	
		PPG5_TOUT0_1	Base timer 11 output pin (1)	-	21	27	
		Correct)					
				Package Pin Number			Remark
		Port Name	Description	TEQFP 144	TEQFP 176	TEQFP 208	
		PPG5_TOUT0_1	Base timer 10 output pin (1)	-	21	27	

Page	Section	Change Results																														
47	6. Port Description 6.1 Port Description List Table 6-1 S6J3310 Series	<p>Revised the below</p> <p>Error)</p> <table border="1"> <thead> <tr> <th rowspan="2">Port Name</th> <th rowspan="2">Description</th> <th colspan="3">Package Pin Number</th> <th rowspan="2">Remark</th> </tr> <tr> <th>TEQFP 144</th> <th>TEQFP 176</th> <th>TEQFP 208</th> </tr> </thead> <tbody> <tr> <td>PPG10_TOUT0_1</td> <td>Base timer 21 output pin (1)</td> <td>-</td> <td>98</td> <td>114</td> <td></td> </tr> </tbody> </table> <p>Correct)</p> <table border="1"> <thead> <tr> <th rowspan="2">Port Name</th> <th rowspan="2">Description</th> <th colspan="3">Package Pin Number</th> <th rowspan="2">Remark</th> </tr> <tr> <th>TEQFP 144</th> <th>TEQFP 176</th> <th>TEQFP 208</th> </tr> </thead> <tbody> <tr> <td>PPG10_TOUT0_1</td> <td>Base timer 20 output pin (1)</td> <td>-</td> <td>98</td> <td>114</td> <td></td> </tr> </tbody> </table>	Port Name	Description	Package Pin Number			Remark	TEQFP 144	TEQFP 176	TEQFP 208	PPG10_TOUT0_1	Base timer 21 output pin (1)	-	98	114		Port Name	Description	Package Pin Number			Remark	TEQFP 144	TEQFP 176	TEQFP 208	PPG10_TOUT0_1	Base timer 20 output pin (1)	-	98	114	
Port Name	Description	Package Pin Number			Remark																											
		TEQFP 144	TEQFP 176	TEQFP 208																												
PPG10_TOUT0_1	Base timer 21 output pin (1)	-	98	114																												
Port Name	Description	Package Pin Number			Remark																											
		TEQFP 144	TEQFP 176	TEQFP 208																												
PPG10_TOUT0_1	Base timer 20 output pin (1)	-	98	114																												
47	6. Port Description 6.1 Port Description List Table 6-1 S6J3310 Series	<p>Revised the below</p> <p>Error)</p> <table border="1"> <thead> <tr> <th rowspan="2">Port Name</th> <th rowspan="2">Description</th> <th colspan="3">Package Pin Number</th> <th rowspan="2">Remark</th> </tr> <tr> <th>TEQFP 144</th> <th>TEQFP 176</th> <th>TEQFP 208</th> </tr> </thead> <tbody> <tr> <td>PPG15_TOUT0_1</td> <td>Base timer 31 output pin (1)</td> <td>-</td> <td>163</td> <td>195</td> <td></td> </tr> </tbody> </table> <p>Correct)</p> <table border="1"> <thead> <tr> <th rowspan="2">Port Name</th> <th rowspan="2">Description</th> <th colspan="3">Package Pin Number</th> <th rowspan="2">Remark</th> </tr> <tr> <th>TEQFP 144</th> <th>TEQFP 176</th> <th>TEQFP 208</th> </tr> </thead> <tbody> <tr> <td>PPG15_TOUT0_1</td> <td>Base timer 30 output pin (1)</td> <td>-</td> <td>163</td> <td>195</td> <td></td> </tr> </tbody> </table>	Port Name	Description	Package Pin Number			Remark	TEQFP 144	TEQFP 176	TEQFP 208	PPG15_TOUT0_1	Base timer 31 output pin (1)	-	163	195		Port Name	Description	Package Pin Number			Remark	TEQFP 144	TEQFP 176	TEQFP 208	PPG15_TOUT0_1	Base timer 30 output pin (1)	-	163	195	
Port Name	Description	Package Pin Number			Remark																											
		TEQFP 144	TEQFP 176	TEQFP 208																												
PPG15_TOUT0_1	Base timer 31 output pin (1)	-	163	195																												
Port Name	Description	Package Pin Number			Remark																											
		TEQFP 144	TEQFP 176	TEQFP 208																												
PPG15_TOUT0_1	Base timer 30 output pin (1)	-	163	195																												
263 to 264	12. Errata	Added section "12. Errata"																														

## Document History

Document Title: S6J3310 Series/S6J3320 Series/S6J3330 Series/S6J3340 Series, 32-bit Microcontroller Traveo™ Family  
 Document Number: 002-10635

Revision	ECN	Orig. of Change	Submission Date	Description of Change
**	5063970	TMOR	01/25/2016	New Spec.
*A	5203759	TMOR	04/06/2016	Correct device revision, Chip ID, LVD spec, DDR-HSSPI spec, Hyper BUS spec, and MediaLB spec For detail, see "Major Changes".
*B	5371697	TMOR	07/25/2016	Additional Handling Devices comments(Method to Switch off VCC12 during Power-off Sequence), LCD BUS I/F AC spec, Internal operation clock frequency comments, LVD comments, and ADC Units vs channel comments The package dimension of TEQFP144 (0.4mm Pitch) correct from the provisional version to the formal version. TYPO: I <sup>2</sup> C Fast Mode For detail, see "Major Changes"
*C	5622186	MATO	02/07/2017	- ID add -I <sub>CC1</sub> , I <sub>CCH</sub> spec add -LCD bus I/F spec revise -Power and RSTX sequence add -Ordering Information revise For detail, see "Major Changes"
*D	5691761	HARA	04/27/2017	Updated logo and copyright.
*E	5782663	MATO	06/26/2017	-Special spec of total maximum clamp current add -I <sub>CC12</sub> , I <sub>CCH12</sub> spec change -Power sequence add -Flash write/erase spec change For detail, see "Major Changes"
*F	5947678	MATO	10/27/2017	-Revision change -Power supply current for S6J33xxxxE add -Ordering Information change For detail, see "Major Changes"
*G	5969954	MATO	11/20/2017	-Function list and Product Description change For detail, see "Major Changes"
*H	6136290	GSHI	04/17/2018	-Document Definition change -Hysteresis voltage add in DC Characteristics -PLLx/SSCGx minimum clock frequencies add in Internal Clock Timing -Ordering Information change

Revision	ECN	Orig. of Change	Submission Date	Description of Change
				For detail, see "Major Changes"
*1	6300353	GSHI	09/05/2018	<ul style="list-style-type: none"> <li>- Add an option limitation for Description of A/D Converter of Product Description.</li> <li>- Update Ethernet Support Functions.</li> <li>- Update Base timer allocation</li> <li>- Added 12. Errata</li> </ul> For detail, see "Major Changes"

## Sales, Solutions, and Legal Information

### Worldwide Sales and Design Support

Cypress maintains a worldwide network of offices, solution centers, manufacturer's representatives, and distributors. To find the office closest to you, visit us at [Cypress Locations](#).

#### Products

Arm® Cortex® Microcontrollers	<a href="http://cypress.com/arm">cypress.com/arm</a>
Automotive	<a href="http://cypress.com/automotive">cypress.com/automotive</a>
Clocks & Buffers	<a href="http://cypress.com/clocks">cypress.com/clocks</a>
Interface	<a href="http://cypress.com/interface">cypress.com/interface</a>
Internet of Things	<a href="http://cypress.com/iot">cypress.com/iot</a>
Memory	<a href="http://cypress.com/memory">cypress.com/memory</a>
Microcontrollers	<a href="http://cypress.com/mcu">cypress.com/mcu</a>
PSoC	<a href="http://cypress.com/psoc">cypress.com/psoc</a>
Power Management ICs	<a href="http://cypress.com/pmic">cypress.com/pmic</a>
Touch Sensing	<a href="http://cypress.com/touch">cypress.com/touch</a>
USB Controllers	<a href="http://cypress.com/usb">cypress.com/usb</a>
Wireless Connectivity	<a href="http://cypress.com/wireless">cypress.com/wireless</a>

#### PSoC® Solutions

[PSoC 1](#) | [PSoC 3](#) | [PSoC 4](#) | [PSoC 5LP](#) | [PSoC 6 MCU](#)

#### Cypress Developer Community

[Community](#) | [Projects](#) | [Video](#) | [Blogs](#) | [Training](#) | [Components](#)

#### Technical Support

[cypress.com/support](http://cypress.com/support)

Arm and Cortex are registered trademarks of Arm Limited (or its subsidiaries) in the US and/or elsewhere.

© Cypress Semiconductor Corporation, 2016-2018. This document is the property of Cypress Semiconductor Corporation and its subsidiaries, including Spansion LLC ("Cypress"). This document, including any software or firmware included or referenced in this document ("Software"), is owned by Cypress under the intellectual property laws and treaties of the United States and other countries worldwide. Cypress reserves all rights under such laws and treaties and does not, except as specifically stated in this paragraph, grant any license under its patents, copyrights, trademarks, or other intellectual property rights. If the Software is not accompanied by a license agreement and you do not otherwise have a written agreement with Cypress governing the use of the Software, then Cypress hereby grants you a personal, non-exclusive, nontransferable license (without the right to sublicense) (1) under its copyright rights in the Software (a) for Software provided in source code form, to modify and reproduce the Software solely for use with Cypress hardware products, only internally within your organization, and (b) to distribute the Software in binary code form externally to end users (either directly or indirectly through resellers and distributors), solely for use on Cypress hardware product units, and (2) under those claims of Cypress's patents that are infringed by the Software (as provided by Cypress, unmodified) to make, use, distribute, and import the Software solely for use with Cypress hardware products. Any other use, reproduction, modification, translation, or compilation of the Software is prohibited.

TO THE EXTENT PERMITTED BY APPLICABLE LAW, CYPRESS MAKES NO WARRANTY OF ANY KIND, EXPRESS OR IMPLIED, WITH REGARD TO THIS DOCUMENT OR ANY SOFTWARE OR ACCOMPANYING HARDWARE, INCLUDING, BUT NOT LIMITED TO, THE IMPLIED WARRANTIES OF MERCHANTABILITY AND FITNESS FOR A PARTICULAR PURPOSE. No computing device can be absolutely secure. Therefore, despite security measures implemented in Cypress hardware or software products, Cypress does not assume any liability arising out of any security breach, such as unauthorized access to or use of a Cypress product. In addition, the products described in these materials may contain design defects or errors known as errata which may cause the product to deviate from published specifications. To the extent permitted by applicable law, Cypress reserves the right to make changes to this document without further notice. Cypress does not assume any liability arising out of the application or use of any product or circuit described in this document. Any information provided in this document, including any sample design information or programming code, is provided only for reference purposes. It is the responsibility of the user of this document to properly design, program, and test the functionality and safety of any application made of this information and any resulting product. Cypress products are not designed, intended, or authorized for use as critical components in systems designed or intended for the operation of weapons, weapons systems, nuclear installations, life-support devices or systems, other medical devices or systems (including resuscitation equipment and surgical implants), pollution control or hazardous substances management, or other uses where the failure of the device or system could cause personal injury, death, or property damage ("Unintended Uses"). A critical component is any component of a device or system whose failure to perform can be reasonably expected to cause the failure of the device or system, or to affect its safety or effectiveness. Cypress is not liable, in whole or in part, and you shall and hereby do release Cypress from any claim, damage, or other liability arising from or related to all Unintended Uses of Cypress products. You shall indemnify and hold Cypress harmless from and against all claims, costs, damages, and other liabilities, including claims for personal injury or death, arising from or related to any Unintended Uses of Cypress products.

Cypress, the Cypress logo, Spansion, the Spansion logo, and combinations thereof, WICED, PSoC, CapSense, EZ-USB, F-RAM, and Traveo are trademarks or registered trademarks of Cypress in the United States and other countries. For a more complete list of Cypress trademarks, visit [cypress.com](http://cypress.com). Other names and brands may be claimed as property of their respective owners.



Компания «ЭлектроПласт» предлагает заключение долгосрочных отношений при поставках импортных электронных компонентов на взаимовыгодных условиях!

Наши преимущества:

- Оперативные поставки широкого спектра электронных компонентов отечественного и импортного производства напрямую от производителей и с крупнейших мировых складов;
- Поставка более 17-ти миллионов наименований электронных компонентов;
- Поставка сложных, дефицитных, либо снятых с производства позиций;
- Оперативные сроки поставки под заказ (от 5 рабочих дней);
- Экспресс доставка в любую точку России;
- Техническая поддержка проекта, помощь в подборе аналогов, поставка прототипов;
- Система менеджмента качества сертифицирована по Международному стандарту ISO 9001;
- Лицензия ФСБ на осуществление работ с использованием сведений, составляющих государственную тайну;
- Поставка специализированных компонентов (Xilinx, Altera, Analog Devices, Intersil, Interpoint, Microsemi, Aeroflex, Peregrine, Syfer, Eurofarad, Texas Instrument, Miteq, Cobham, E2V, MA-COM, Hittite, Mini-Circuits, General Dynamics и др.);

Помимо этого, одним из направлений компании «ЭлектроПласт» является направление «Источники питания». Мы предлагаем Вам помощь Конструкторского отдела:

- Подбор оптимального решения, техническое обоснование при выборе компонента;
- Подбор аналогов;
- Консультации по применению компонента;
- Поставка образцов и прототипов;
- Техническая поддержка проекта;
- Защита от снятия компонента с производства.



#### Как с нами связаться

**Телефон:** 8 (812) 309 58 32 (многоканальный)

**Факс:** 8 (812) 320-02-42

**Электронная почта:** [org@eplast1.ru](mailto:org@eplast1.ru)

**Адрес:** 198099, г. Санкт-Петербург, ул. Калинина, дом 2, корпус 4, литера А.