

Description

The FS1012 MEMS mass flow sensor module measures the flow rate using the thermo-transfer (calorimetric) principle. The FS1012 is capable of measuring a gas or liquid medium.

The FS1012 offers key advantages over resistor-based flow solutions. The sensor utilizes thermopile sensing, which provides an excellent signal-to-noise ratio. The sensor comprises a “solid” thermal isolation technology and silicon-carbide coating to protect it from abrasive wear and provides robustness and long-term reliability. In comparison, other sensors typically contain a fragile membrane above an etched cavity for the thermal isolation base.

The FS1012 features the sensor fully assembled and wire-bonded out to a 6-pin header. Wetted materials consist of a glass fiber reinforced PA66 resin, epoxy, and silicon carbide.

Features

- Gas or liquid mediums
- Robust “solid” isolation technology
- Resistant to surface contamination
- No cavity to cause clogging
- Resistant to vibration and pressure shock
- Low power application
- Sensitive at low flow rates and differential pressure levels
- Fast response: <5ms
- Millivolt output
- Supply voltage: 3V to 5V
- Module operating temperature range: 0°C to +85°C

Typical Applications

- Process controls and monitoring
- Oil and gas leak detection
- HVAC and air control systems
- CPAP and respiratory devices
- Liquid dispensing system

FS1012 Flow Sensor Module



Basic Application Circuits

Figure 1. Single-Ended Circuit Example

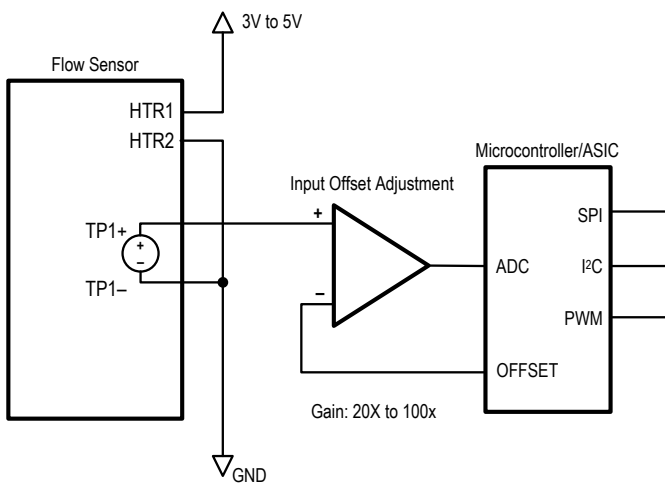
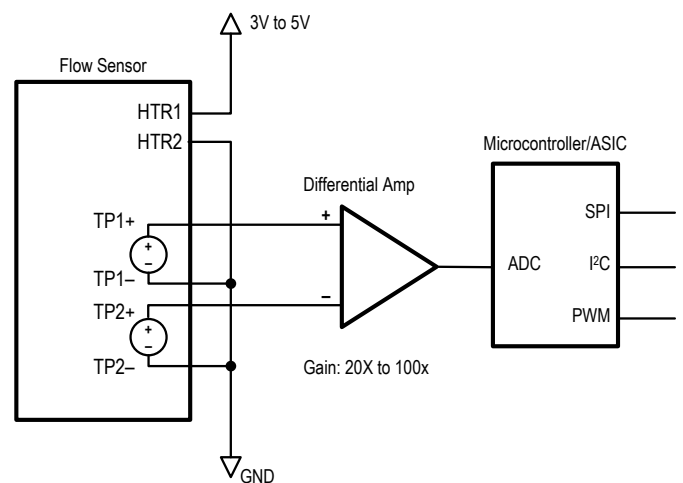
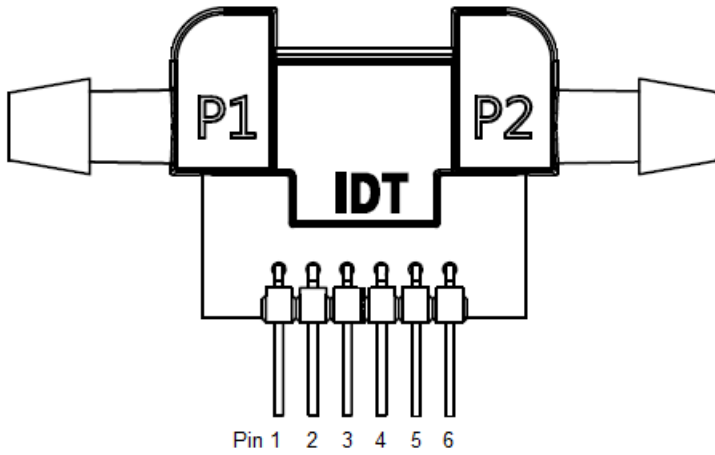

Figure 2. Differential Circuit Example



Pin Assignments

Figure 3. Pin Assignments for Module – Top View



Pin Descriptions

Table 1. Pin Descriptions

Pin Number	Pad Name	Type	Description
1	TP1+	Output	Thermopile 1 (+)
2	TP1-	Output	Thermopile 1 (-)
3	HTR1	Input	Heater
4	HTR2	Input	Heater
5	TP2-	Output	Thermopile 2 (-)
6	TP2+	Output	Thermopile 2 (+)

Absolute Maximum Ratings

The absolute maximum ratings are stress ratings only. Stresses greater than those listed below can cause permanent damage to the device. Functional operation of the FS1012 at absolute maximum ratings is not implied. Exposure to absolute maximum rating conditions may affect device reliability.

Table 2. Absolute Maximum Ratings

Symbol	Parameter	Conditions	Minimum	Maximum	Units
V_H	Heater Voltage Supply			5.6	V
T_{STOR}	Storage Temperature		-50	130	°C
P_{BURST}	Burst Pressure			10	bar

Recommended Operating Conditions

Table 3. Recommended Operating Conditions

Symbol	Parameter	Minimum	Typical	Maximum	Units
T_{AMB}	Ambient Operating Temperature ^[a]	0		85	°C
I_{HTR_CC}	Heater Driving Current – Constant Current ^[a]		10	20	mA
V_{HTR_CV}	Heater Driving Voltage – Constant Voltage ^[a]		3	5.6	V

[a] Sensor specifications are tested at the wafer die level.

Electrical Characteristics

Table 4. Electrical Characteristics

Note: See important notes at the end of the table.

Symbol	Parameter	Conditions	Minimum	Typical	Maximum	Units
R_H	Heater Resistor ^[a]		230	290	400	Ω
α_{HTR}	Heater Temperature Coefficient of Resistance ^[a]			300		ppm/°C
V_{TP_OUT}	Thermopile Output ^[a]	3V driving voltage, in air, 20°C, no flow	30	35	60	mV
R_{TP}	Thermopile Resistance ^[a]	20°C	100	210	300	K Ω
$V_{TP_OUTDIFF}$	Thermopile Differential Output ^[a]	3V driving voltage, in air, 20°C, no flow	-1	0	1	mV
t_{RESP}	Response Time			5		ms

Symbol	Parameter	Conditions	Minimum	Typical	Maximum	Units
Standard Gas Flow Range^{[b], [c]}						
	Gas Flow	FS1012-1020-NG	0		2 (2000)	SLPM (SCCM)
		FS1012-1100-NG	0		10 (10000)	SLPM (SCCM)
Standard Liquid Flow Range^{[b], [c]}						
	Liquid Flow	FS1012-1001-LQ	0		0.5 (500)	SLPM (SCCM)
		FS1012-1002-LQ	0		1.0 (1000)	SLPM (SCCM)

[a] Sensor specifications are tested at the wafer die level.

[b] SLPM: Standard liter per minute.

[c] SCCM: Standard cubic centimeter per minute.

Flow Curves

The flow output curves are typical values at room conditions. The heater voltage is set at 5VDC. Flow input is from P1 to P2 out.

In general, use TP1 to measure gas flow and TP2 for liquid flow.

Figure 4. FS1012-1020-NG Flow Curve

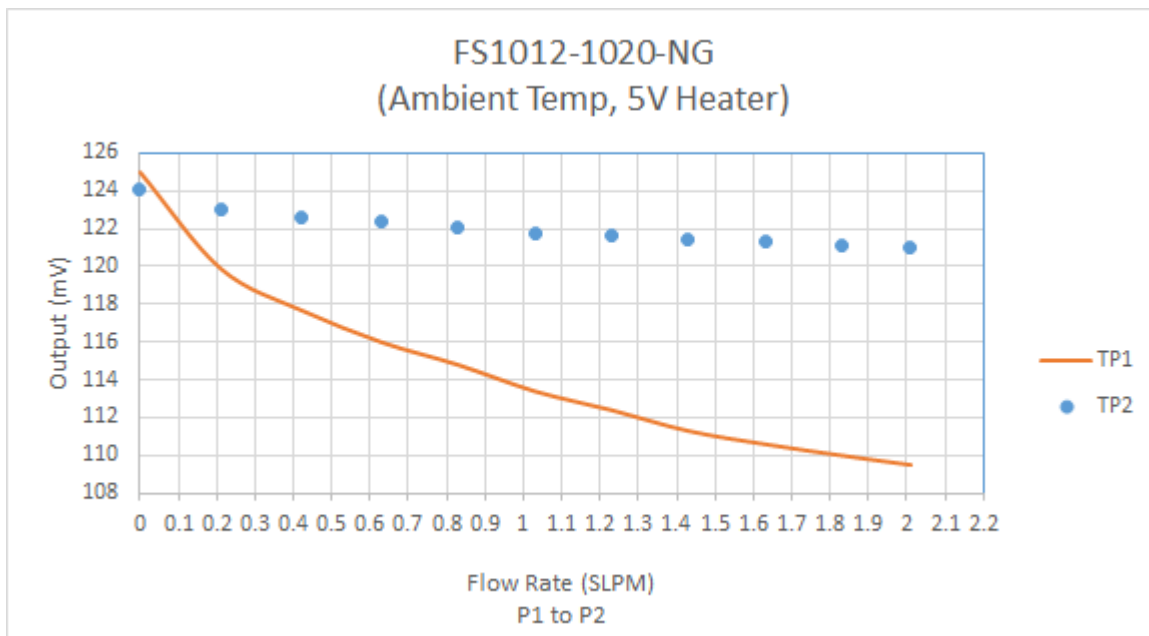

Figure 5. FS1012-1100-NG Flow Curve

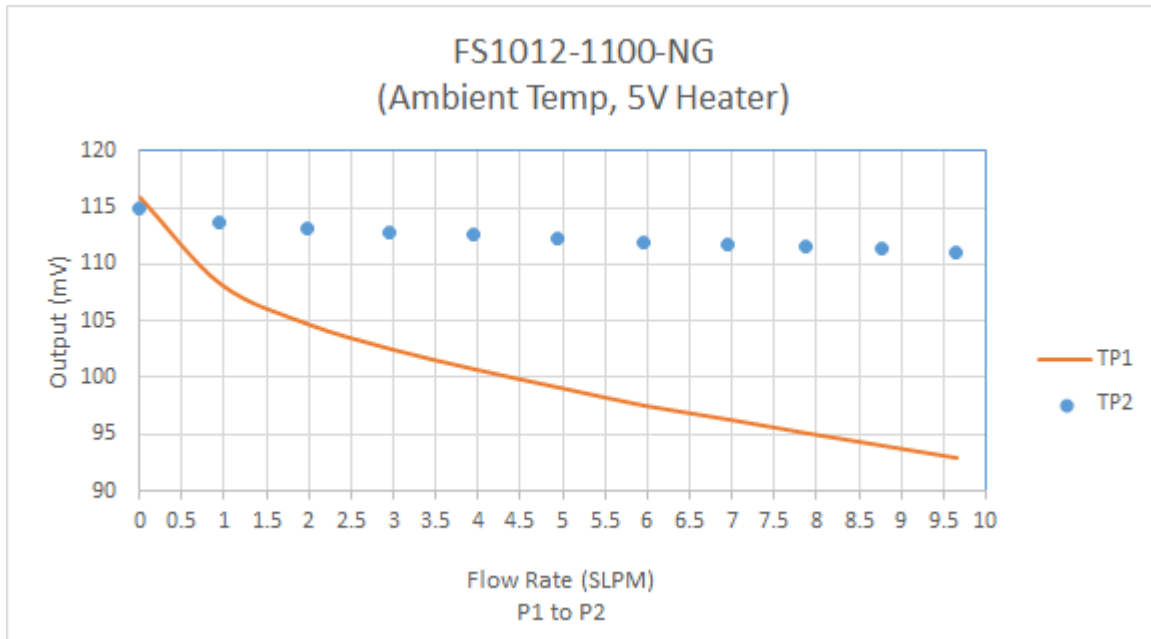

Figure 6. FS1012-1001-LQ Flow Curve

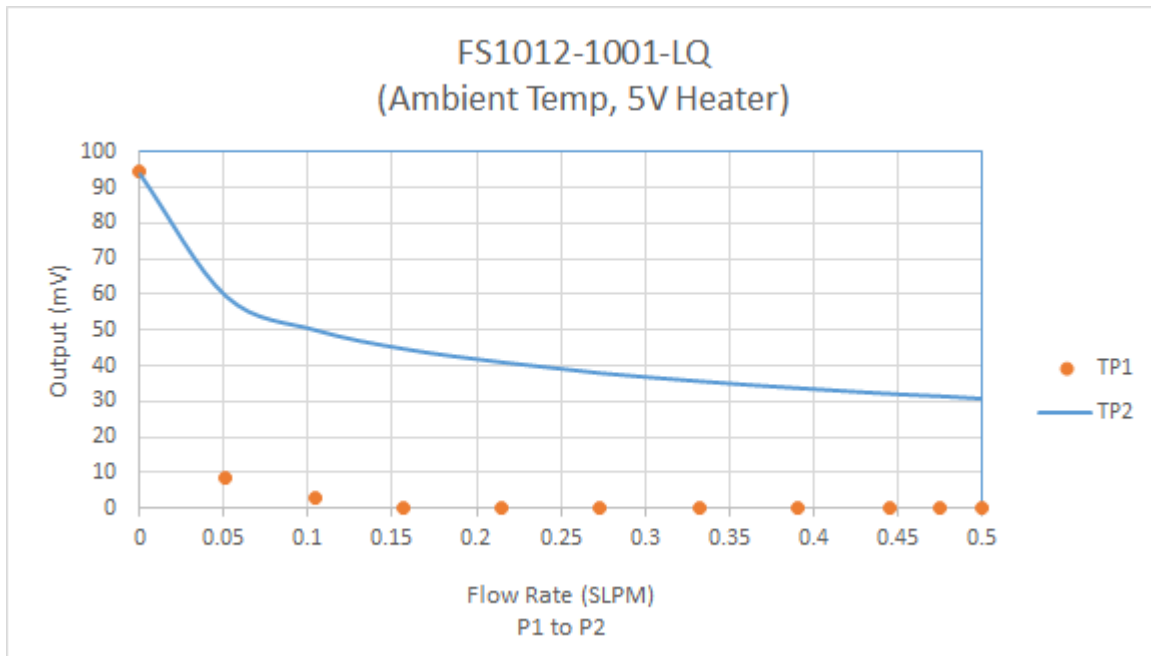
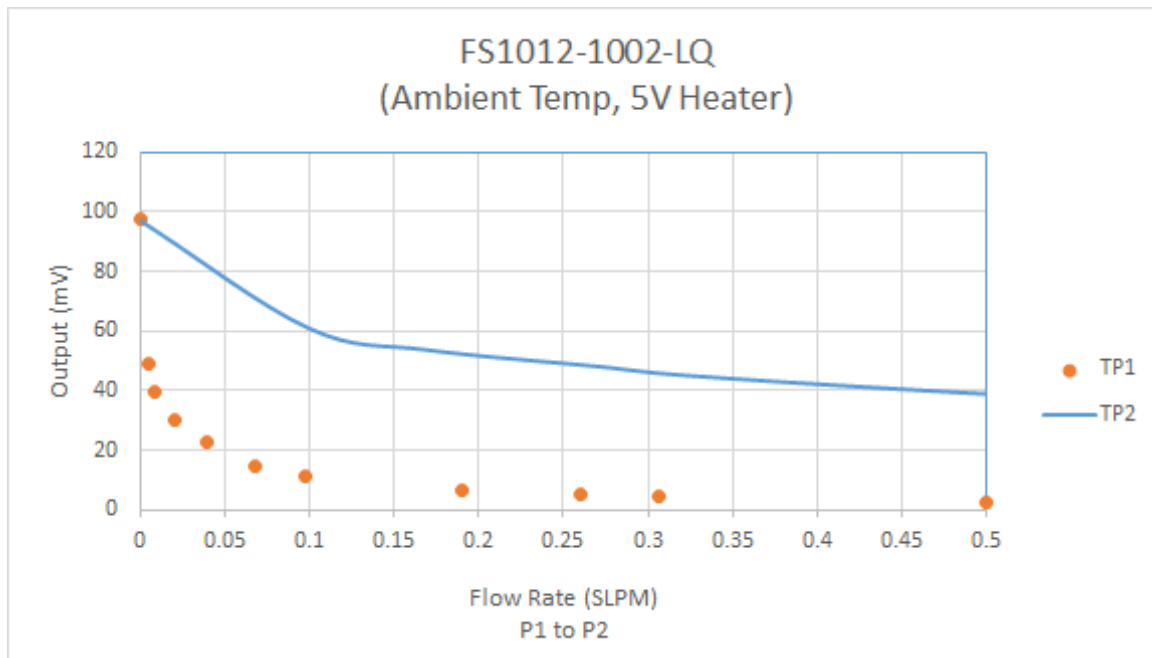
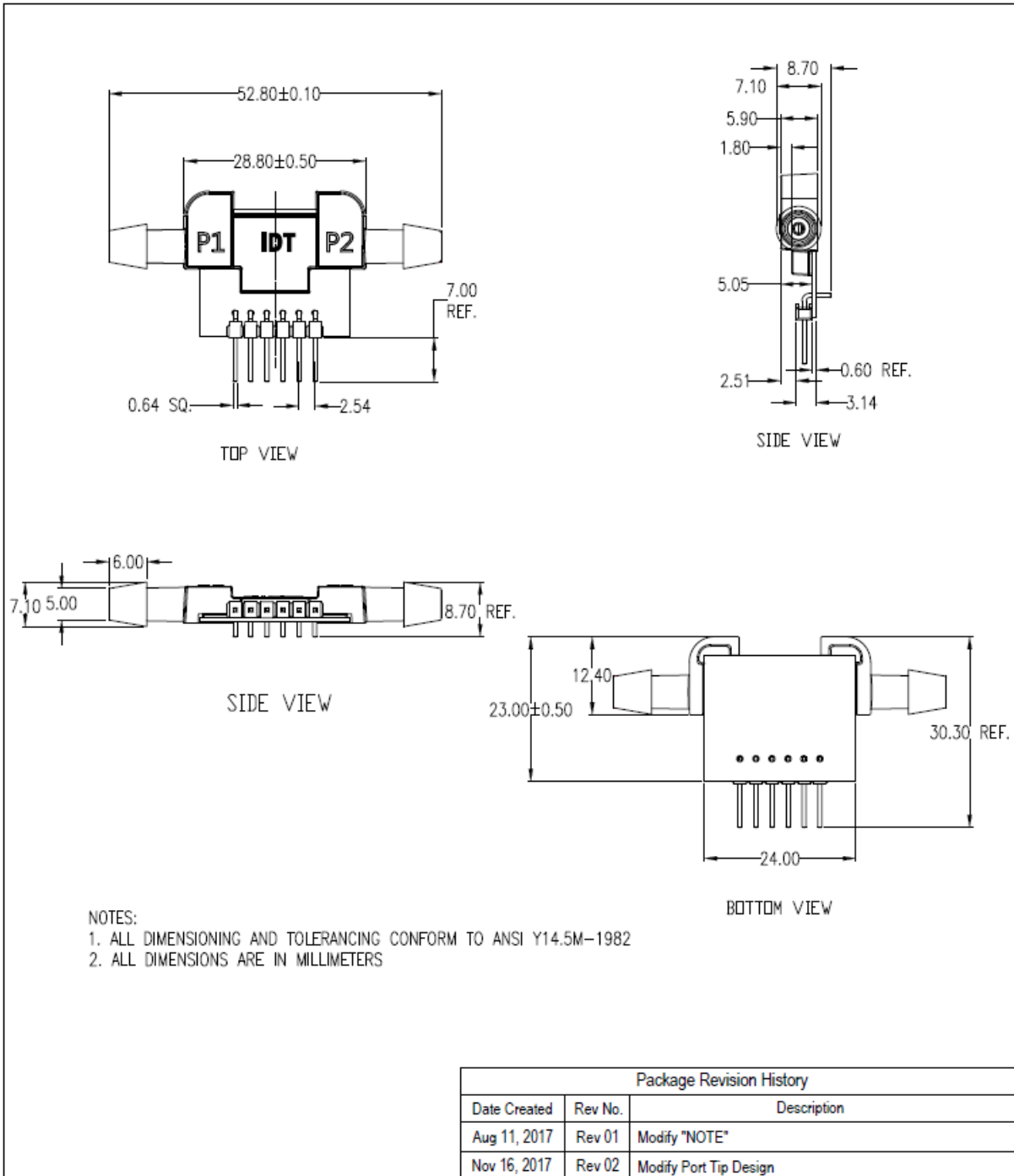

Figure 7. FS1012-1002-LQ Flow Curve



Package Outline Drawings

Figure 8. FS1012 Module Outline Drawings



Ordering Information

Note: The part code depends on the application. In the part code, NG refers to “non-corrosive gas” and LQ refers to “liquid.”

Orderable Part Number	Description and Package	Shipping Packaging	Temperature
FS1012-1020-NG	0 to 2 SLPM gas flow sensor mounted on a circuit board with a flow housing	Box	0°C to +85°C
FS1012-1100-NG	0 to 10 SLPM gas flow sensor mounted on a circuit board with a flow housing	Box	0°C to +85°C
FS1012-1001-LQ	0 to 0.5 SLPM (500 SCCM) liquid flow sensor mounted on a circuit board with a flow housing	Box	0°C to +85°C
FS1012-1002-LQ	0 to 1.0 SLPM (1000 SCCM) liquid flow sensor mounted on a circuit board with a flow housing	Box	0°C to +85°C

Revision History

Revision Date	Description of Change
November 19, 2018	Update module dimensions drawing, change Table 2 spec, added flow curves.
September 8, 2017	Updated module dimensions drawing.
July 20, 2017	Initial release of the datasheet.



Corporate Headquarters

6024 Silver Creek Valley Road
San Jose, CA 95138
www.IDT.com

Sales

1-800-345-7015 or 408-284-8200
Fax: 408-284-2775
www.IDT.com/go/sales

Tech Support

www.IDT.com/go/support

DISCLAIMER Integrated Device Technology, Inc. (IDT) and its affiliated companies (herein referred to as "IDT") reserve the right to modify the products and/or specifications described herein at any time, without notice, at IDT's sole discretion. Performance specifications and operating parameters of the described products are determined in an independent state and are not guaranteed to perform the same way when installed in customer products. The information contained herein is provided without representation or warranty of any kind, whether express or implied, including, but not limited to, the suitability of IDT's products for any particular purpose, an implied warranty of merchantability, or non-infringement of the intellectual property rights of others. This document is presented only as a guide and does not convey any license under intellectual property rights of IDT or any third parties.

IDT's products are not intended for use in applications involving extreme environmental conditions or in life support systems or similar devices where the failure or malfunction of an IDT product can be reasonably expected to significantly affect the health or safety of users. Anyone using an IDT product in such a manner does so at their own risk, absent an express, written agreement by IDT.

Integrated Device Technology, IDT and the IDT logo are trademarks or registered trademarks of IDT and its subsidiaries in the United States and other countries. Other trademarks used herein are the property of IDT or their respective third party owners. For datasheet type definitions and a glossary of common terms, visit www.idt.com/go/glossary. All contents of this document are copyright of Integrated Device Technology, Inc. All rights reserved.



Компания «ЭлектроПласт» предлагает заключение долгосрочных отношений при поставках импортных электронных компонентов на взаимовыгодных условиях!

Наши преимущества:

- Оперативные поставки широкого спектра электронных компонентов отечественного и импортного производства напрямую от производителей и с крупнейших мировых складов;
- Поставка более 17-ти миллионов наименований электронных компонентов;
- Поставка сложных, дефицитных, либо снятых с производства позиций;
- Оперативные сроки поставки под заказ (от 5 рабочих дней);
- Экспресс доставка в любую точку России;
- Техническая поддержка проекта, помощь в подборе аналогов, поставка прототипов;
- Система менеджмента качества сертифицирована по Международному стандарту ISO 9001;
- Лицензия ФСБ на осуществление работ с использованием сведений, составляющих государственную тайну;
- Поставка специализированных компонентов (Xilinx, Altera, Analog Devices, Intersil, Interpoint, Microsemi, Aeroflex, Peregrine, Syfer, Eurofarad, Texas Instrument, Miteq, Cobham, E2V, MA-COM, Hittite, Mini-Circuits, General Dynamics и др.);

Помимо этого, одним из направлений компании «ЭлектроПласт» является направление «Источники питания». Мы предлагаем Вам помощь Конструкторского отдела:

- Подбор оптимального решения, техническое обоснование при выборе компонента;
- Подбор аналогов;
- Консультации по применению компонента;
- Поставка образцов и прототипов;
- Техническая поддержка проекта;
- Защита от снятия компонента с производства.



Как с нами связаться

Телефон: 8 (812) 309 58 32 (многоканальный)

Факс: 8 (812) 320-02-42

Электронная почта: org@eplast1.ru

Адрес: 198099, г. Санкт-Петербург, ул. Калинина, дом 2, корпус 4, литера А.