

NHD-14432WG-ATFH-V#T

Graphic Liquid Crystal Display Module

NHD-	Newhaven Display
14432-	144 x 32 pixels
WG-	Display type: Graphic
A-	Model
T-	White LED backlight
F-	FSTN (+)
H-	Transflective, 6:00 View, Wide Temperature (-20°C ~ +70°C)
V#T-	Built-in Positive Voltage
	RoHS Compliant

Newhaven Display International, Inc.

2511 Technology Drive, Suite 101

Elgin IL, 60124

Ph: 847-844-8795

Fax: 847-844-8796

www.newhavendisplay.com

nhtech@newhavendisplay.com

nhsales@newhavendisplay.com

Document Revision History

Revision	Date	Description	Changed by
0	2/28/2008	Initial Release	-
1	4/5/2010	User guide reformat	BE
2	5/5/2010	Updates	BE
3	5/10/2010	BLOCK DIAGRAM UPDATED	BE
4	5/25/2010	Contrast updated	BE

Functions and Features

- 144x32 pixels
- Built-in ST7920 Controller
- +5.0V power supply
- 1/32 duty
- RoHS Compliant

Mechanical Drawing

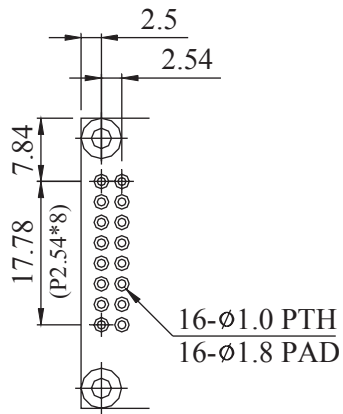
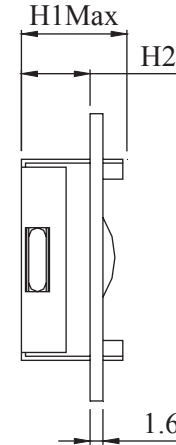
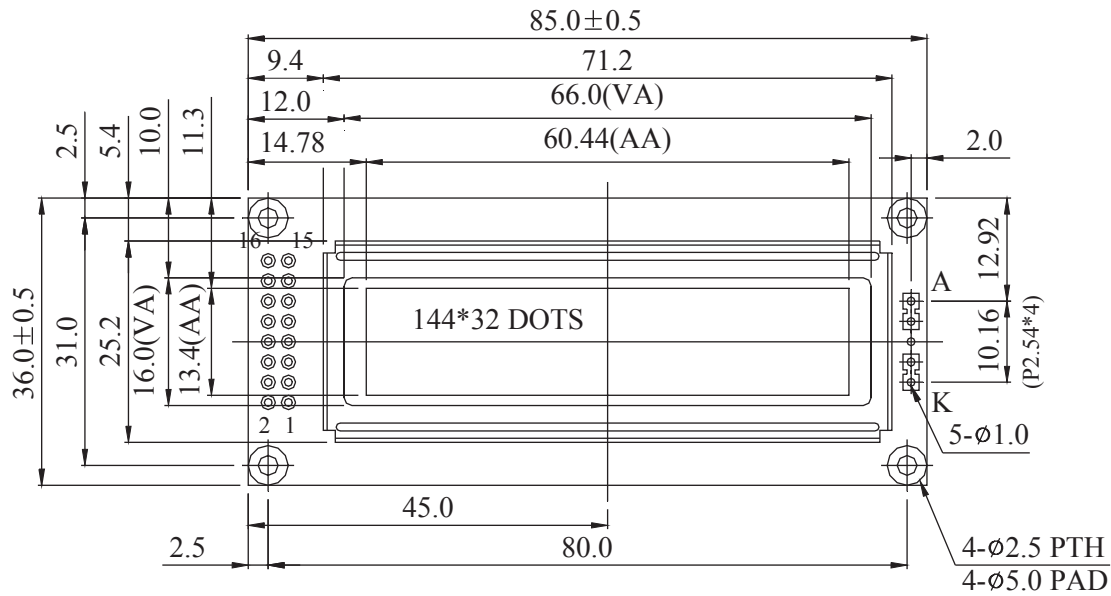

PIN DETAIL

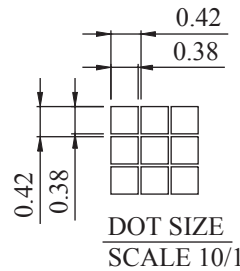

LED H/L B/L

	High	Low
H1	13.2	12.1
H2	8.6	7.5

LED B/L Drive Method

1. Drive from A, K

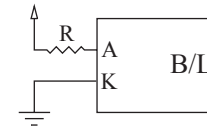

2. Drive from pin15, pin16

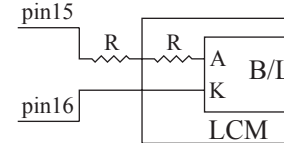

3. Drive from Vdd, Vss

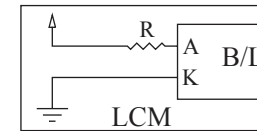

(Contrast performance may go down.)

PIN NO.	SYMBOL
1	Vss
2	Vdd
3	Vo
4	RS
5	R/W
6	E
7	DB0
8	DB1
9	DB2
10	DB3
11	DB4
12	DB5
13	DB6
14	DB7
15	LED+
16	LED-

Newhaven Display	
Part No.	NHD-14432WG-ATFH-V#T

Pin Description and Wiring Diagram

Pin No.	Symbol	External Connection	Function Description
1	VSS	Power Supply	Ground
2	VDD	Power Supply	Power supply for Logic (+5.0V)
3	V0	Adj Power Supply	Power Supply for contrast (approx. +4.8V)
4	RS	MPU	Register select: 1=Data, 0=Instruction
5	R/W	MPU	Read/Write select signal, R/W=1: Read R/W: =0: Write
6	E	MPU	Operation enable signal. Falling edge triggered.
7-14	DB0-DB7	MPU	This is an 8-bit-directional data bus
15	LED+	Power Supply	Power for LED backlight (+3.5V)
16	LED-	Power Supply	Ground for Backlight

Recommended LCD connector: 2.54mm pitch pins

Backlight connector: - **Mates with:** -

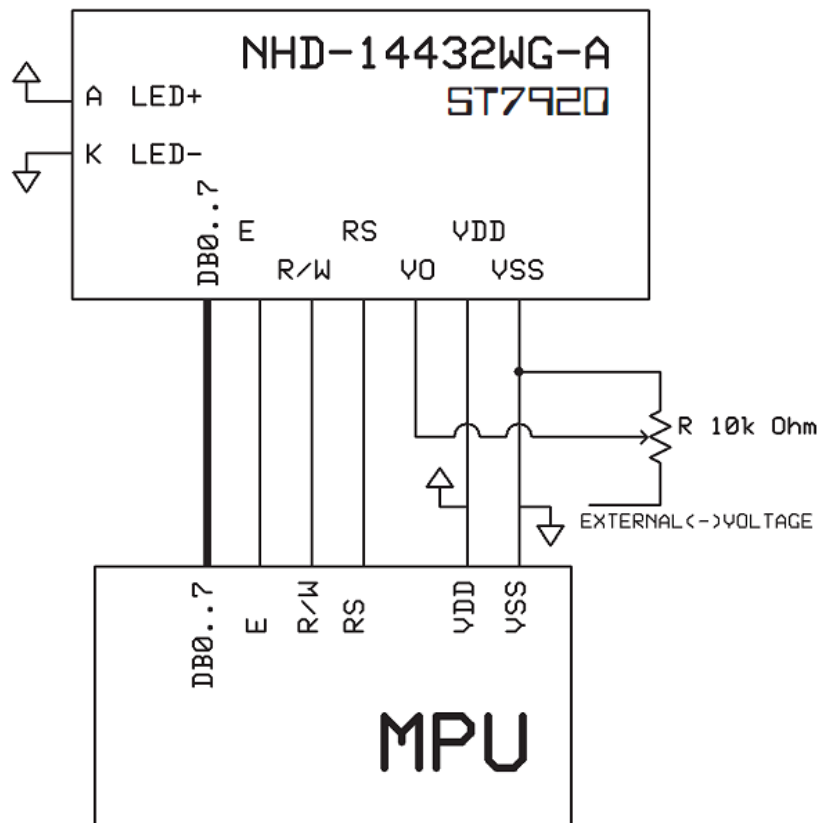

Electrical Characteristics

Item	Symbol	Condition	Min.	Typ.	Max.	Unit
Operating Temperature Range	Top	Absolute Max	-20	-	+70	°C
Storage Temperature Range	Tst	Absolute Max	-30	-	+80	°C
Supply Voltage	VDD		4.5	5.0	5.5	V
Supply Current	IDD	Ta=25°, VDD=5.0V	1.6	2.2	3.5	mA
Supply for LCD (contrast)	V0	Ta=25°		4.8		V
"H" Level input	Vih		0.7VDD		VDD	V
"L" Level input	Vil		-0.3		0.6	V
"H" Level output	Voh		0.8VDD		VDD	V
"L" Level output	Vol		0		0.4	V
Backlight Supply Voltage	Vled		-	3.5	3.9	V
Backlight Supply Current	Iled	Vled=3.5V	-	40	80	mA
Backlight Lifetime	-	Iled=40mA	-	50,000	-	Hrs.

Optical Characteristics

Item	Symbol	Condition	Min.	Typ.	Max.	Unit
Viewing Angle - Vertical (top)	AH	Cr ≥ 2	-	20	-	°
Viewing Angle- Vertical (bottom)	AH	Cr ≥ 2	-	40	-	°
Viewing Angle- Horizontal (left)	AV	Cr ≥ 2	-	30	-	°
Viewing Angle - Horizontal (right)	AV	Cr ≥ 2	-	30	-	°
Contrast Ratio	Cr			3		
Response Time (rise)	Tr			200	300	ms
Response Time (fall)	Tf			200	300	ms

Controller Information

Built-in ST7920. Download specification at http://www.newhavendisplay.com/app_notes/ST7920.pdf

Table of Commands

Instruction set 1: (RE=0: basic instruction)

Ins	code										Description	Exec time (540KHZ)
	RS	RW	DB7	DB6	DB5	DB4	DB3	DB2	DB1	DB0		
CLEAR	0	0	0	0	0	0	0	0	0	1	Fill DDRAM with "20H", and set DDRAM address counter (AC) to "00H"	1.6 ms
HOME	0	0	0	0	0	0	0	0	0	1 X	Set DDRAM address counter (AC) to "00H", and put cursor to origin ; the content of DDRAM are not changed	72us
ENTRY MODE	0	0	0	0	0	0	0	0	1	I/D S	Set cursor position and display shift when doing write or read operation	72us
DISPLAY ON/OFF	0	0	0	0	0	0	0	1	D	C B	D=1: display ON C=1: cursor ON B=1: blink ON	72 us
CURSOR DISPLAY CONTROL	0	0	0	0	0	1	S/C	R/L	X	X	Cursor position and display shift control ; the content of DDRAM are not changed	72 us
FUNCTION SET	0	0	0	0	1	DL	X	0	RE	X X	DL=1 8-BIT interface DL=0 4-BIT interface RE=1: extended instruction RE=0: basic instruction	72 us
SET CGRAM ADDR.	0	0	0	1	AC5	AC4	AC3	AC2	AC1	AC0	Set CGRAM address to address counter (AC) Make sure that in extended instruction SR=0 (scroll or RAM address select)	72 us
SET DDRAM ADDR.	0	0	1	0	AC5	AC4	AC3	AC2	AC1	AC0	Set DDRAM address to address counter (AC) AC6 is fixed to 0	72 us
READ BUSY FLAG (BF) & ADDR.	0	1	BF	AC6	AC5	AC4	AC3	AC2	AC1	AC0	Read busy flag (BF) for completion of internal operation, also Read out the value of address counter (AC)	0 us
WRITE RAM	1	0	D7	D6	D5	D4	D3	D2	D1	D0	Write data to internal RAM (DDRAM/CGRAM/IRAM/GDRAM)	72 us
READ RAM	1	1	D7	D6	D5	D4	D3	D2	D1	D0	Read data from internal RAM (DDRAM/CGRAM/IRAM/GDRAM)	72 us

Instruction set 2: (RE=1: extended instruction)

Inst.	code										description	Exec. time (540KHZ)
	RS	RW	DB7	DB6	DB5	DB4	DB3	DB2	DB1	DB0		
STAND BY	0	0	0	0	0	0	0	0	0	1	Enter stand by mode, any other instruction can terminate (Com1..32 halted, only Com33 ICON can display)	72 us
SCROLL or RAM ADDR. SELECT	0	0	0	0	0	0	0	0	0	1 SR	SR=1: enable vertical scroll position SR=0: enable IRAM address (extended instruction) SR=0: enable CGRAM address(basic instruction)	72 us
REVERSE	0	0	0	0	0	0	0	0	1 R1	R0	Select 1 out of 4 line (in DDRAM) and decide whether to reverse the display by toggling this instruction R1,R0 initial value is 00	72 us
EXTENDED FUNCTION SET	0	0	0	0	1 DL	X	1 RE	G	0		DL=1 8-BIT interface DL=0 4-BIT interface RE=1: extended instruction set RE=0: basic instruction set G=1 :graphic display ON G=0 :graphic display OFF	72 us
SET IRAM or SCROLL ADDR	0	0	0	1 AC5	AC4	AC3	AC2	AC1	AC0		SR=1: AC5~AC0 the address of vertical scroll SR=0: AC3~AC0 the address of ICON RAM	72 us
SET GRAPHIC RAM ADDR.	0	0	1 AC6	AC5	AC4	AC3	AC2	AC1	AC0		Set GDRAM address to address counter (AC) First set vertical address and the horizontal address by consecutive writing Vertical address range AC6...AC0 Horizontal address range AC3...AC0	72 us

Timing Characteristics

DC Characteristics ($T_A = 25^{\circ}\text{C}$, $V_{DD} = 2.7\text{ V} - 4.5\text{ V}$)

Symbol	Characteristics	Test Condition	Min.	Typ.	Max.	Unit
V_{DD}	Operating Voltage	-	2.7	-	5.5	V
V_{LCD}	LCD Voltage	$V_0 - V_{SS}$	3.0	-	7	V
I_{CC}	Power Supply Current	$f_{OSC} = 530\text{KHz}$, $V_{DD} = 3.0\text{V}$ $R_f = 18\text{K}\Omega$	-	0.20	0.45	mA
V_{IH1}	Input High Voltage (Except OSC1)	-	$0.7V_{DD}$	-	V_{DD}	V
V_{IL1}	Input Low Voltage (Except OSC1)	-	-0.3	-	0.6	V
V_{IH2}	Input High Voltage (OSC1)	-	$V_{DD} - 1$	-	V_{DD}	V
V_{IL2}	Input Low Voltage (OSC1)	-	-	-	1.0	V
V_{OH1}	Output High Voltage (DB0 - DB7)	$I_{OH} = -0.1\text{mA}$	$0.8V_{DD}$	-	V_{DD}	V
V_{OL1}	Output Low Voltage (DB0 - DB7)	$I_{OL} = 0.1\text{mA}$	-	-	0.1	V
V_{OH2}	Output High Voltage (Except DB0 - DB7)	$I_{OH} = -0.04\text{mA}$	$0.8V_{DD}$	-	V_{DD}	V
V_{OL2}	Output Low Voltage (Except DB0 - DB7)	$I_{OL} = 0.04\text{mA}$	-	-	$0.1V_{DD}$	V
I_{LEAK}	Input Leakage Current	$V_{IN} = 0\text{V to } V_{DD}$	-1	-	1	μA
I_{PUP}	Pull Up MOS Current	$V_{DD} = 3\text{V}$	22	27	32	μA

MPU write data to ST7920

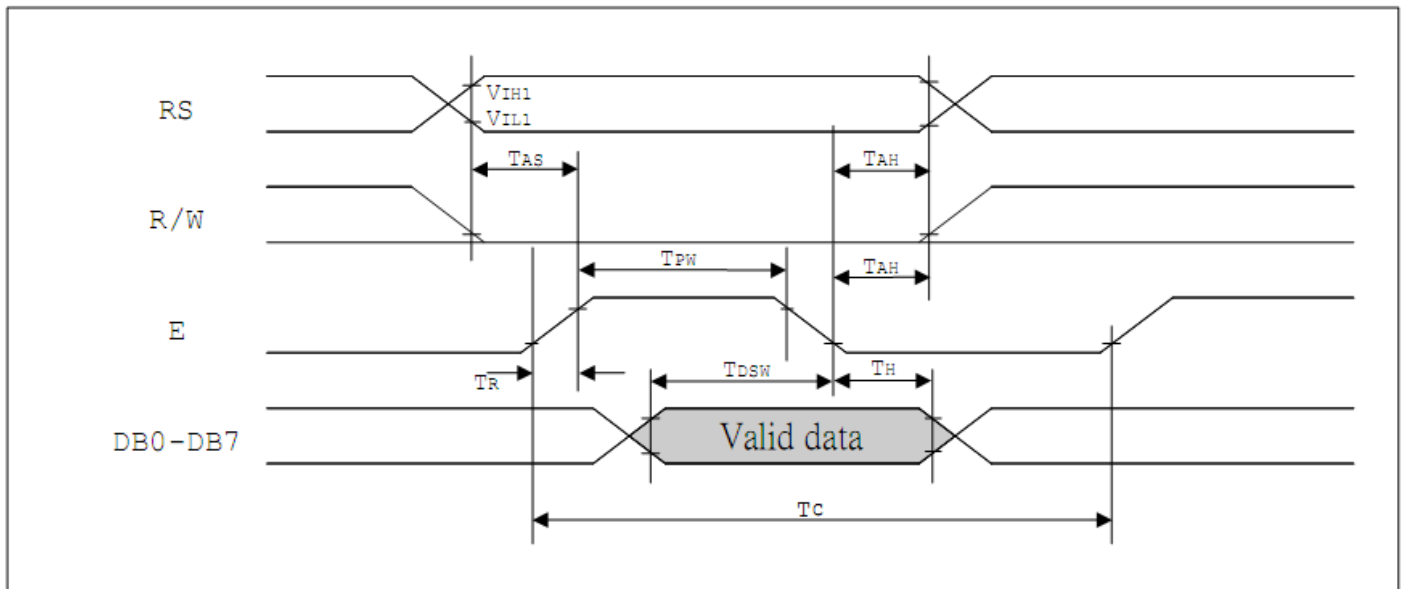

MPU read data from ST7920

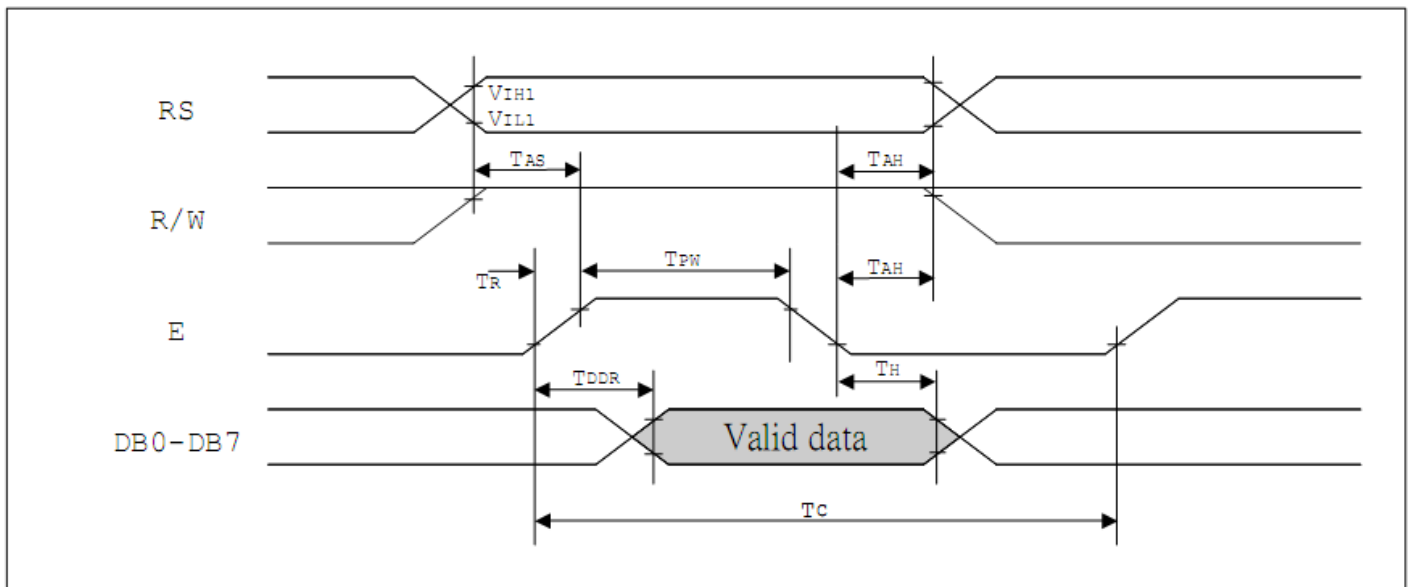

Example Initialization Program

```
//-----  
#include <REG52.H>  
#include "AL.h"  
sbit ID = P3^0;  
sbit RW = P3^7;  
sbit E = P3^4;  
  
//-----  
void Init()  
{  
    Wcom(0x38);  
    Wcom(0x0C);  
    Wcom(0x06);  
    Wcom(0x02);  
    Wcom(0x01);  
    delay(10);  
    Row = 0x80;  
    for(Counthi = 1; Counthi <=32; Counthi++)  
    {  
        Wcom(0x3E);  
        Wcom(Row);  
        Wcom(0x80);  
        for(Count = 1; Count <=40; Count++)  
        {  
            Wdata(0x00);  
        }  
        Row++;  
    }  
}  
  
//-----  
void Wcom(char i)  
{  
    P1 = i;  
    ID = 0; //Reset P3.0  
    RW = 0; //Reset P3.7  
    E = 1; //Set P3.4  
    delay(1);  
    E = 0; //Reset P3.4  
}  
  
void Wdata(char i)  
{  
    P1 = i;  
    ID = 1; //Set P3.0  
    RW = 0; //Reset P3.7  
    E = 1; //Set P3.4  
    delay(1);  
    E = 0; //Reset P3.4  
}
```

Quality Information

Test Item	Content of Test	Test Condition	Note
High Temperature storage	Endurance test applying the high storage temperature for a long time.	+80°C , 48hrs	2
Low Temperature storage	Endurance test applying the low storage temperature for a long time.	-30°C , 48hrs	1,2
High Temperature Operation	Endurance test applying the electric stress (voltage & current) and the high thermal stress for a long time.	+70°C , 48hrs	2
Low Temperature Operation	Endurance test applying the electric stress (voltage & current) and the low thermal stress for a long time.	-20°C , 48hrs	1,2
High Temperature / Humidity Operation	Endurance test applying the electric stress (voltage & current) and the high thermal with high humidity stress for a long time.	+40°C , 90% RH , 48hrs	1,2
Thermal Shock resistance	Endurance test applying the electric stress (voltage & current) during a cycle of low and high thermal stress.	0°C,30min -> 25°C,5min -> 50°C,30min = 1 cycle 10 cycles	
Vibration test	Endurance test applying vibration to simulate transportation and use.	10-55Hz , 15mm amplitude. 60 sec in each of 3 directions X,Y,Z For 15 minutes	3
Static electricity test	Endurance test applying electric static discharge.	VS=800V, RS=1.5kΩ, CS=100pF One time	

Note 1: No condensation to be observed.

Note 2: Conducted after 4 hours of storage at 25°C, 0%RH.

Note 3: Test performed on product itself, not inside a container.

Precautions for using LCDs/LCMs

See Precautions at www.newhavendisplay.com/specs/precautions.pdf

Warranty Information and Terms & Conditions

http://www.newhavendisplay.com/index.php?main_page=terms



Компания «ЭлектроПласт» предлагает заключение долгосрочных отношений при поставках импортных электронных компонентов на взаимовыгодных условиях!

Наши преимущества:

- Оперативные поставки широкого спектра электронных компонентов отечественного и импортного производства напрямую от производителей и с крупнейших мировых складов;
- Поставка более 17-ти миллионов наименований электронных компонентов;
- Поставка сложных, дефицитных, либо снятых с производства позиций;
- Оперативные сроки поставки под заказ (от 5 рабочих дней);
- Экспресс доставка в любую точку России;
- Техническая поддержка проекта, помощь в подборе аналогов, поставка прототипов;
- Система менеджмента качества сертифицирована по Международному стандарту ISO 9001;
- Лицензия ФСБ на осуществление работ с использованием сведений, составляющих государственную тайну;
- Поставка специализированных компонентов (Xilinx, Altera, Analog Devices, Intersil, Interpoint, Microsemi, Aeroflex, Peregrine, Syfer, Eurofarad, Texas Instrument, Miteq, Cobham, E2V, MA-COM, Hittite, Mini-Circuits, General Dynamics и др.);

Помимо этого, одним из направлений компании «ЭлектроПласт» является направление «Источники питания». Мы предлагаем Вам помощь Конструкторского отдела:

- Подбор оптимального решения, техническое обоснование при выборе компонента;
- Подбор аналогов;
- Консультации по применению компонента;
- Поставка образцов и прототипов;
- Техническая поддержка проекта;
- Защита от снятия компонента с производства.



Как с нами связаться

Телефон: 8 (812) 309 58 32 (многоканальный)

Факс: 8 (812) 320-02-42

Электронная почта: org@eplast1.ru

Адрес: 198099, г. Санкт-Петербург, ул. Калинина, дом 2, корпус 4, литера А.