

General Description

830s211 is a 1-to-1 Differential-to- LVCMOS/ LVTTL translator and a member of the family of High Performance Clock Solutions from IDT. The differential input is highly flexible and can accept the following input types: LVPECL, LVDS, LVHSTL, SSTL and HCSL. The small 8-lead SOIC footprint makes this device ideal for use in applications with limited board space.

Features

- One LVCMOS/LVTTL output
- Differential CLK, nCLK input pair
- CLK, nCLK pair can accept the following differential input levels: LVPECL, LVDS, LVHSTL, SSTL, HCSL
- Maximum output frequency: 350MHz
- Part-to-part skew: 525ps (maximum)
- Additive Phase jitter, RMS: 0.11ps (typical)
- Small 8 lead SOIC package saves board space
- Full 3.3V and 2.5V operating supply
- -40°C to 85°C ambient operating temperature
- Available in lead-free (RoHS 6) package

Block Diagram

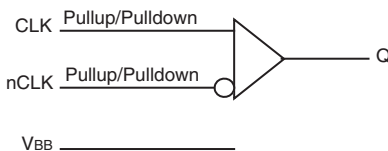

Pin Assignment

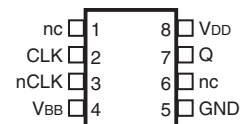

830s211

8-Lead SOIC

3.9mm x 4.9mm x 1.375mm package body

M Package

Top View

Table 1. Pin Descriptions

Number	Name	Type		Description
1, 6	nc	Unused		No connect.
2	CLK	Input	Pullup/ Pulldown	Non-inverting differential clock input.
3	nCLK	Input	Pullup/ Pulldown	Inverting differential clock input.
4	V _{BB}	Output		Output reference voltage.
5	GND	Power		Power supply ground.
7	Q	Output		Single-ended clock output. LVCMOS / LVTTTL interface levels.
8	V _{DD}	Power		Positive supply pin.

NOTE: Pullup and Pulldown refer to internal input resistors. See Table 2, *Pin Characteristics*, for typical values.

Table 2. Pin Characteristics

Symbol	Parameter	Test Conditions	Minimum	Typical	Maximum	Units
C _{IN}	Input Capacitance			4		pF
R _{PULLUP}	Input Pullup Resistor			51		kΩ
R _{PULLDOWN}	Input Pulldown Resistor			51		kΩ
C _{PD}	Power Dissipation Capacitance	V _{DD} = 3.465V		10		pF
		V _{DD} = 2.625V		8		pF
R _{OUT}	Output Impedance	V _{DD} = 3.3V		10		Ω
		V _{DD} = 2.5V		12		Ω

Absolute Maximum Ratings

NOTE: Stresses beyond those listed under *Absolute Maximum Ratings* may cause permanent damage to the device. These ratings are stress specifications only. Functional operation of product at these conditions or any conditions beyond those listed in the *DC Characteristics* or *AC Characteristics* is not implied. Exposure to absolute maximum rating conditions for extended periods may affect product reliability.

Item	Rating
Supply Voltage, V_{DD}	4.6V
Inputs, V_I	-0.5V to $V_{DD} + 0.5V$
Outputs, V_O	-0.5V to $V_{DD} + 0.5V$
Package Thermal Impedance, θ_{JA}	93.1°C/W (0 mps)
Storage Temperature, T_{STG}	-65°C to 150°C

DC Electrical Characteristics

Table 3A. Power Supply DC Characteristics, $V_{DD} = 3.3V \pm 5\%$, $T_A = -40^\circ C$ to $85^\circ C$

Symbol	Parameter	Test Conditions	Minimum	Typical	Maximum	Units
V_{DD}	Positive Supply Voltage		3.135	3.3	3.465	V
I_{DD}	Power Supply Current				12	mA

Table 3B. Power Supply DC Characteristics, $V_{DD} = 2.5V \pm 5\%$, $T_A = -40^\circ C$ to $85^\circ C$

Symbol	Parameter	Test Conditions	Minimum	Typical	Maximum	Units
V_{DD}	Positive Supply Voltage		2.375	2.5	2.625	V
I_{DD}	Power Supply Current				11	mA

Table 3C. LVCMOS/LVTTL DC Characteristics, $V_{DD} = 3.3V \pm 5\%$ or $2.5V \pm 5\%$, $T_A = -40^\circ C$ to $85^\circ C$

Symbol	Parameter	Test Conditions	Minimum	Typical	Maximum	Units
V_{OH}	Output High Voltage; NOTE 1	$V_{DD} = 3.3V$	2.6			V
		$V_{DD} = 2.5V$	1.8			V
V_{OL}	Output Low Voltage; NOTE 1	$V_{DD} = 3.3V$ or $2.5V$			0.5	V

NOTE 1: Outputs terminated with 50Ω to $V_{DD}/2$. See Parameter Measurement Information, *Output Load Test Circuit diagrams*.

Table 3D. Differential DC Characteristics, $V_{DD} = 3.3V \pm 5\%$ or $2.5V \pm 5\%$, $T_A = -40^\circ C$ to $85^\circ C$

Symbol	Parameter	Test Conditions	Minimum	Typical	Maximum	Units
I_{IH}	Input High Current	$V_{DD} = V_{IN} = 3.465V$ or $2.625V$			150	μA
I_{IL}	Input Low Current	$V_{DD} = 3.465V$ or $2.625V$, $V_{IN} = 0V$	-150			μA
V_{PP}	Peak-to-Peak Voltage; NOTE 1		0.15		1.5	V
V_{CMR}	Common Mode Input Voltage; NOTE 1, 2		GND + 0.5		$V_{DD} - 0.85$	V
V_{BB}	Output Voltage Reference		$V_{DD} - 1.4$	$V_{DD} - 1.3$	$V_{DD} - 1.2$	V

 NOTE 1: V_{IL} should not be less than $-0.3V$.

 NOTE 2: Common mode input voltage is defined as V_{IH} .

AC Electrical Characteristics

Table 4A. AC Characteristics, $V_{DD} = 3.3V \pm 5\%$, $T_A = -40^\circ C$ to $85^\circ C$

Parameter	Symbol	Test Conditions	Minimum	Typical	Maximum	Units
f_{MAX}	Output Frequency			350		MHz
t_{PD}	Propagation Delay, NOTE 1		0.95		1.95	ns
$t_{sk}(pp)$	Part-to-Part Skew; NOTE 2, 3				525	ps
f_{jit}	Buffer Additive Phase jitter, RMS; refer to Additive Phase Jitter Section	350MHz, Integration Range (12kHz – 20MHz)		0.11	1	ps
t_R / t_F	Output Rise/Fall Time	20% to 80%	85		500	ps
odc	Output Duty Cycle	$f \leq 266MHz$	47		53	%

 NOTE 1: Measured from the differential input crossing point to the output at $V_{DD}/2$.

 NOTE 2: Defined as skew between outputs on different devices operating at the same supply voltage and with equal load conditions. Using the same type of input on each device, the output is measured at $V_{DD}/2$.

NOTE 3: This parameter is defined in accordance with JEDEC Standard 65.

Table 4B. AC Characteristics, $V_{DD} = 2.5V \pm 5\%$, $T_A = -40^\circ C$ to $85^\circ C$

Parameter	Symbol	Test Conditions	Minimum	Typical	Maximum	Units
f_{MAX}	Output Frequency			350		MHz
t_{PD}	Propagation Delay, NOTE 1		1		2	ns
$t_{sk}(pp)$	Part-to-Part Skew; NOTE 2, 3				550	ps
f_{jit}	Buffer Additive Phase jitter, RMS; refer to Additive Phase Jitter Section	350MHz, Integration Range (12kHz – 20MHz)		0.11	1	ps
t_R / t_F	Output Rise/Fall Time	20% to 80%	125		500	ps
odc	Output Duty Cycle	$f \leq 266MHz$	47		53	%

 NOTE 1: Measured from the differential input crossing point to the output at $V_{DD}/2$.

 NOTE 2: Defined as skew between outputs on different devices operating at the same supply voltage and with equal load conditions. Using the same type of input on each device, the output is measured at $V_{DD}/2$.

NOTE 3: This parameter is defined in accordance with JEDEC Standard 65.

Additive Phase Jitter

The spectral purity in a band at a specific offset from the fundamental compared to the power of the fundamental is called the ***dBc Phase Noise***. This value is normally expressed using a Phase noise plot and is most often the specified plot in many applications. Phase noise is defined as the ratio of the noise power present in a 1Hz band at a specified offset from the fundamental frequency to the power value of the fundamental. This ratio is expressed in decibels (dBm) or a ratio of the power in the 1Hz band

to the power in the fundamental. When the required offset is specified, the phase noise is called a ***dBc*** value, which simply means dBm at a specified offset from the fundamental. By investigating jitter in the frequency domain, we get a better understanding of its effects on the desired application over the entire time record of the signal. It is mathematically possible to calculate an expected bit error rate given a phase noise plot.

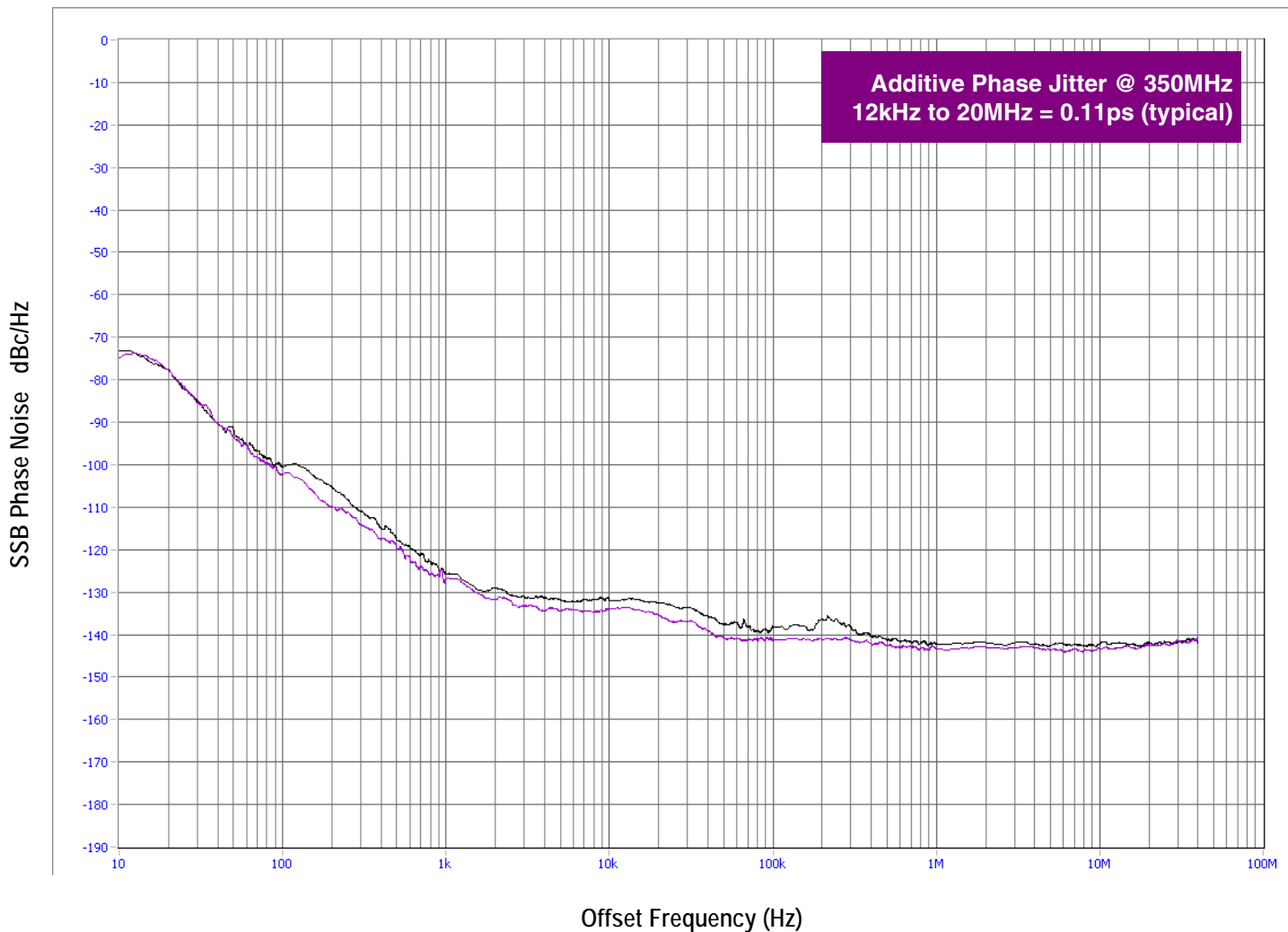

As with most timing specifications, phase noise measurements has issues relating to the limitations of the equipment. Often the noise floor of the equipment is higher than the noise floor of the device.

This is illustrated above. The device meets the noise floor of what is shown, but can actually be lower. The phase noise is dependent on the input source and measurement equipment.

Parameter Measurement Information

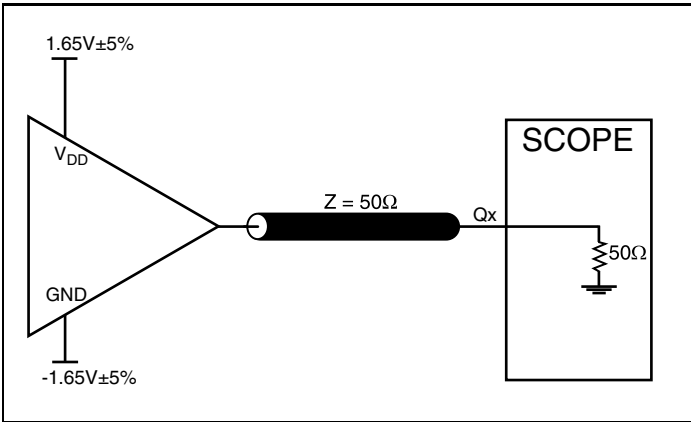

3.3V Core/3.3V LVCMOS Output Load AC Test Circuit

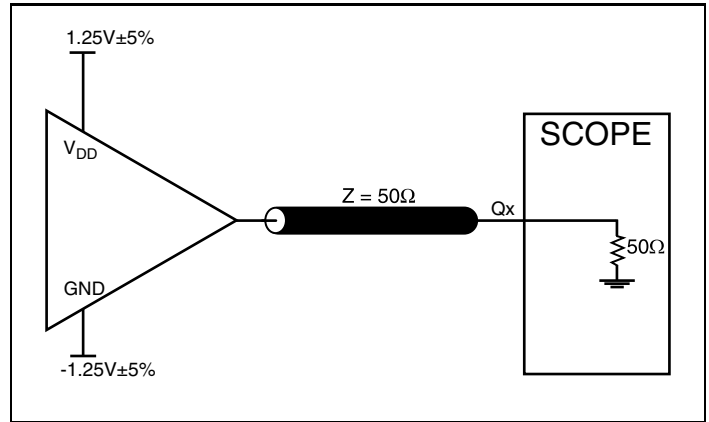

2.5V Core/2.5V LVCMOS Output Load AC Test Circuit

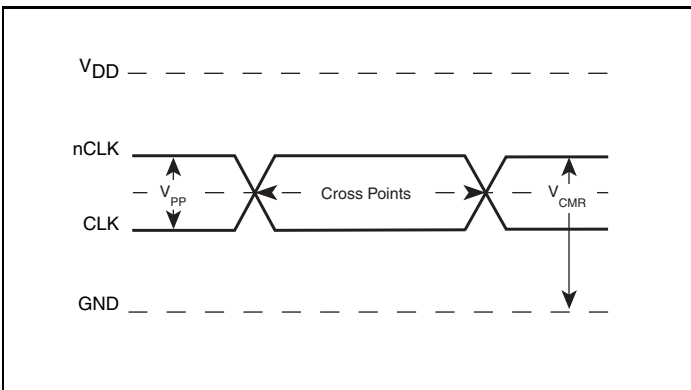

Differential Input Level

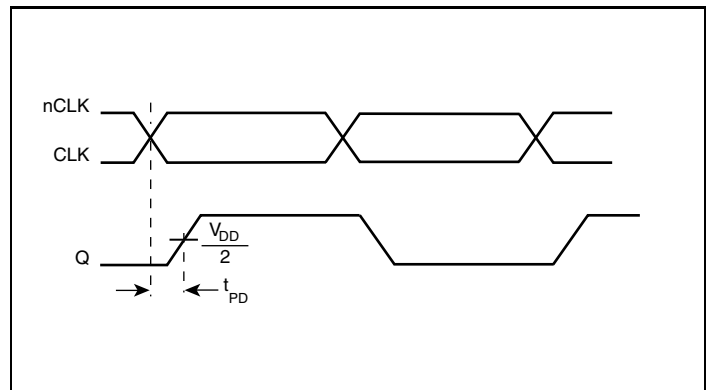

Propagation Delay

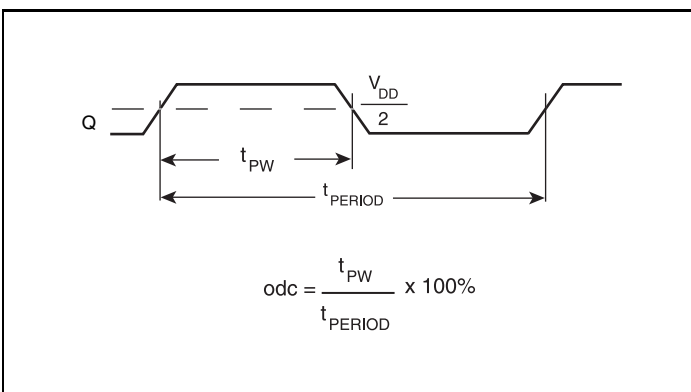

Output Duty Cycle/Pulse Width/Period

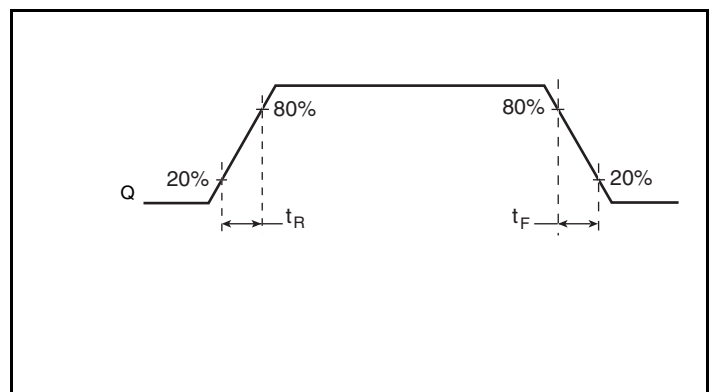

Output Rise/Fall Time

Parameter Measurement Information, continued

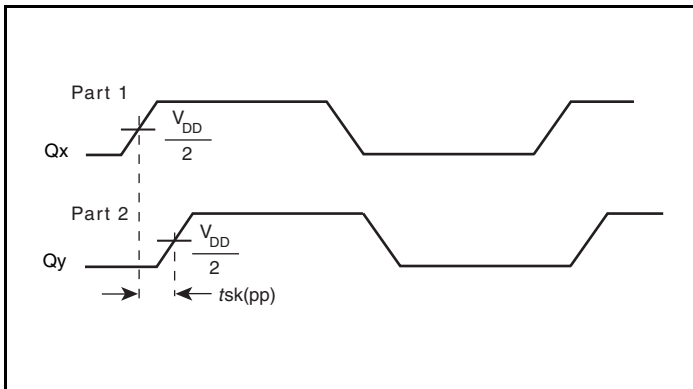

Part-to-Part Skew

Application Information

Wiring the Differential Input to Accept Single Ended Levels

Figure 1 shows how the differential input can be wired to accept single ended levels. The reference voltage $V_{REF} = V_{DD}/2$ is generated by the bias resistors R1, R2 and C1. This bias circuit should be located as close as possible to the input pin. The ratio of R1 and R2 might need to be adjusted to position the V_{REF} in the center of the input voltage swing. For example, if the input clock swing is only 2.5V and $V_{DD} = 3.3V$, V_{REF} should be 1.25V and $R2/R1 = 0.609$.

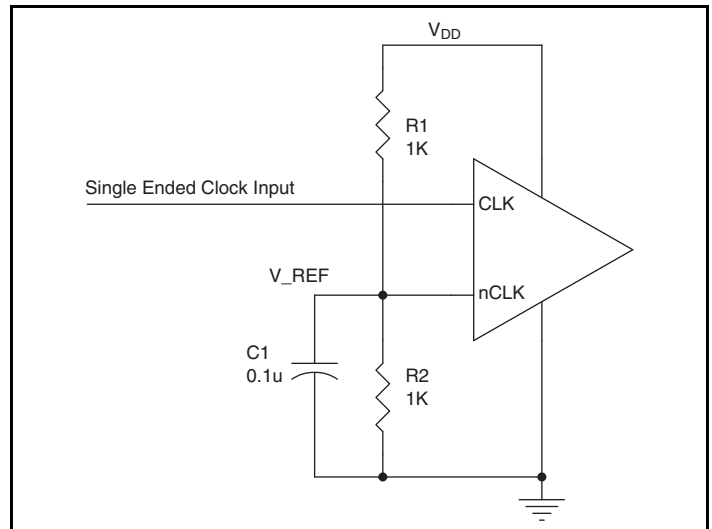

Figure 1. Single-Ended Signal Driving Differential Input

Differential Clock Input Interface

The CLK /nCLK accepts LVDS, LVPECL, LVHSTL, SSTL, HCSL and other differential signals. Both V_{SWING} and V_{OH} must meet the V_{PP} and V_{CMR} input requirements. Figures 2A to 2F show interface examples for the HiPerClockS CLK/nCLK input driven by the most common driver types. The input interfaces suggested here are examples only. Please consult with the vendor of the driver

component to confirm the driver termination requirements. For example, in Figure 2A, the input termination applies for IDT HiPerClockS open emitter LVHSTL drivers. If you are using an LVHSTL driver from another vendor, use their termination recommendation.

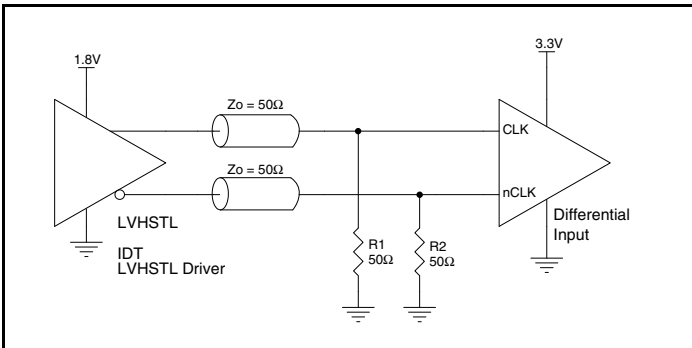

Figure 2A. HiPerClockS CLK/nCLK Input Driven by an IDT Open Emitter HiPerClockS LVHSTL Driver

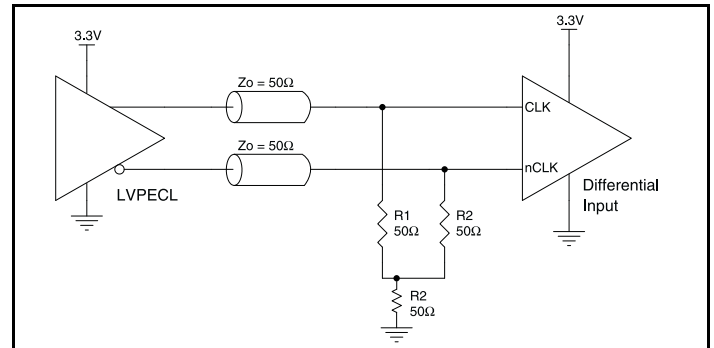

Figure 2B. HiPerClockS CLK/nCLK Input Driven by a 3.3V LVPECL Driver

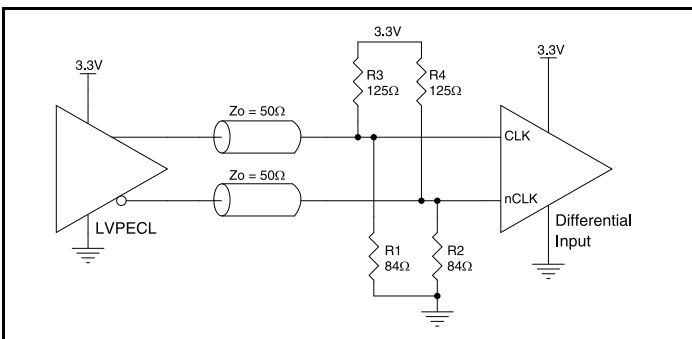

Figure 2C. HiPerClockS CLK/nCLK Input Driven by a 3.3V LVPECL Driver

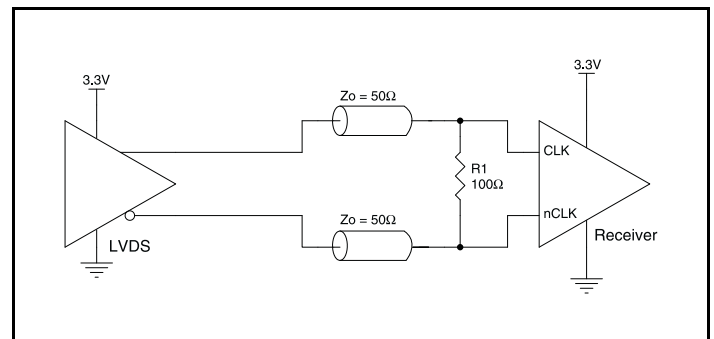

Figure 2D. HiPerClockS CLK/nCLK Input Driven by a 3.3V LVDS Driver

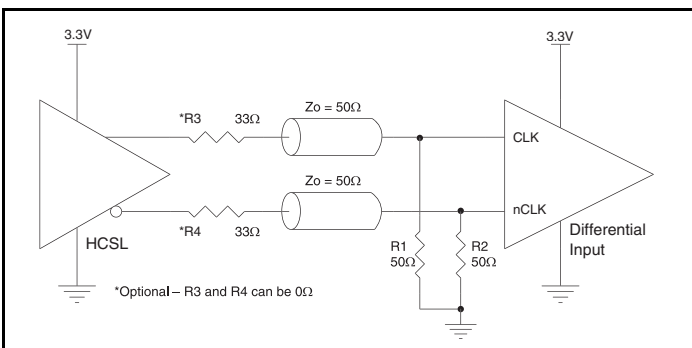

Figure 2E. HiPerClockS CLK/nCLK Input Driven by a 3.3V HCSL Driver

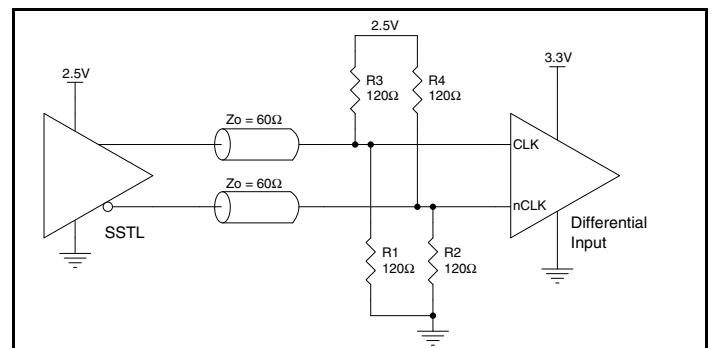

Figure 2F. HiPerClockS CLK/nCLK Input Driven by a 2.5V SSTL Driver

Reliability Information

Table 5. θ_{JA} vs. Air Flow Table for a 8 Lead SOIC

θ_{JA} vs. Air Flow			
Meters per Second	0	1	2.5
Multi-Layer PCB, JEDEC Standard Test Boards	93.1°C/W	84.3°C/W	79.6°C/W

Transistor Count

The transistor count for 830s21I is: 214

Package Outline and Package Dimensions

Package Outline - M Suffix for 8 Lead SOIC

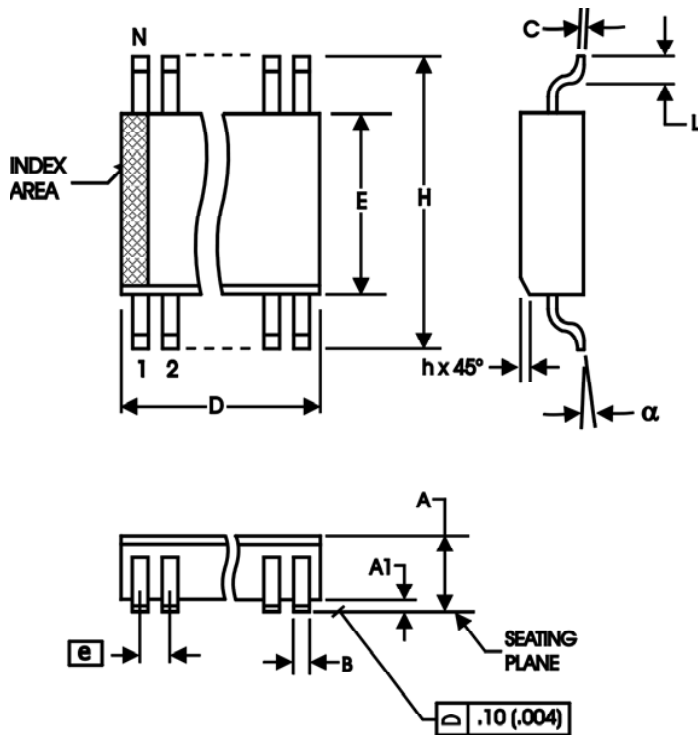

Table 6. Package Dimensions

All Dimensions in Millimeters		
Symbol	Minimum	Maximum
N	8	
A	1.35	1.75
A1	0.10	0.25
B	0.33	0.51
C	0.19	0.25
D	4.80	5.00
E	3.80	4.00
e	1.27 Basic	
H	5.80	6.20
h	0.25	0.50
L	0.40	1.27
α	0°	8°

Reference Document: JEDEC Publication 95, MS-012

Ordering Information

Table 7. Ordering Information

Part/Order Number	Marking	Package	Shipping Packaging	Temperature
830S21AMILF	30S21AIL	"Lead-Free" 8 Lead SOIC	Tube	-40°C to 85°C
830S21AMILFT	30S21AIL	"Lead-Free" 8 Lead SOIC	Tape & Reel	-40°C to 85°C

Revision History

]

Revision Date	Description of Change
December 12, 2015	<ul style="list-style-type: none"> ▪ Removed ICS Chip and HiPerClockS under General Description. ▪ Removed ICS in the part numbers. ▪ Removed LF note at the bottom of the Ordering Information table. ▪ Removed the quantity of 2500 from the Tape & Reel in the Ordering information table. ▪ Updated datasheet header and footer.



Corporate Headquarters
6024 Silver Creek Valley Road
San Jose, CA 95138 USA
www.IDT.com

Sales
1-800-345-7015 or 408-284-8200
Fax: 408-284-2775
www.IDT.com/go/sales

Tech Support
www.idt.com/go/support

DISCLAIMER Integrated Device Technology, Inc. (IDT) reserves the right to modify the products and/or specifications described herein at any time, without notice, at IDT's sole discretion. Performance specifications and operating parameters of the described products are determined in an independent state and are not guaranteed to perform the same way when installed in customer products. The information contained herein is provided without representation or warranty of any kind, whether express or implied, including, but not limited to, the suitability of IDT's products for any particular purpose, an implied warranty of merchantability, or non-infringement of the intellectual property rights of others. This document is presented only as a guide and does not convey any license under intellectual property rights of IDT or any third parties.

IDT's products are not intended for use in applications involving extreme environmental conditions or in life support systems or similar devices where the failure or malfunction of an IDT product can be reasonably expected to significantly affect the health or safety of users. Anyone using an IDT product in such a manner does so at their own risk, absent an express, written agreement by IDT.

Integrated Device Technology, IDT and the IDT logo are trademarks or registered trademarks of IDT and its subsidiaries in the United States and other countries. Other trademarks used herein are the property of IDT or their respective third party owners.

For datasheet type definitions and a glossary of common terms, visit www.idt.com/go/glossary.

Copyright ©2015 Integrated Device Technology, Inc. All rights reserved.



Компания «ЭлектроПласт» предлагает заключение долгосрочных отношений при поставках импортных электронных компонентов на взаимовыгодных условиях!

Наши преимущества:

- Оперативные поставки широкого спектра электронных компонентов отечественного и импортного производства напрямую от производителей и с крупнейших мировых складов;
- Поставка более 17-ти миллионов наименований электронных компонентов;
- Поставка сложных, дефицитных, либо снятых с производства позиций;
- Оперативные сроки поставки под заказ (от 5 рабочих дней);
- Экспресс доставка в любую точку России;
- Техническая поддержка проекта, помощь в подборе аналогов, поставка прототипов;
- Система менеджмента качества сертифицирована по Международному стандарту ISO 9001;
- Лицензия ФСБ на осуществление работ с использованием сведений, составляющих государственную тайну;
- Поставка специализированных компонентов (Xilinx, Altera, Analog Devices, Intersil, Interpoint, Microsemi, Aeroflex, Peregrine, Syfer, Eurofarad, Texas Instrument, Miteq, Cobham, E2V, MA-COM, Hittite, Mini-Circuits, General Dynamics и др.);

Помимо этого, одним из направлений компании «ЭлектроПласт» является направление «Источники питания». Мы предлагаем Вам помощь Конструкторского отдела:

- Подбор оптимального решения, техническое обоснование при выборе компонента;
- Подбор аналогов;
- Консультации по применению компонента;
- Поставка образцов и прототипов;
- Техническая поддержка проекта;
- Защита от снятия компонента с производства.



Как с нами связаться

Телефон: 8 (812) 309 58 32 (многоканальный)

Факс: 8 (812) 320-02-42

Электронная почта: org@eplast1.ru

Адрес: 198099, г. Санкт-Петербург, ул. Калинина, дом 2, корпус 4, литера А.