



## 20 mΩ, 2.0 A Fast Turn On Integrated Power Switch with Discharge

### General Description

The SLG59M1515V is a 20 mΩ 2.0 A single-channel power switch with configurable slew rate control. The device can enable fast power rail turn on with big cap loading. Internal circuit limits max inrush current to prevent device damage. The product is packaged in an ultra-small 1.0x1.6mm package.

### Features

- 1.0 x 1.6 x 0.55 mm STDFN 8L package (2 fused pins for drain and 2 fused pins for source)
- Logic level ON pin capable of supporting 0.85 V CMOS Logic
- Discharged Load when off
- Fast Turn On time
  - 25 μs, Tune Cap = 0.1 nF, C<sub>LOAD</sub> = 1 μF @ 100 mA
  - 95 μs, Tune Cap = 0.5 nF, C<sub>LOAD</sub> = 10 μF @ 2.5 A
- Low RDS<sub>ON</sub> while supporting 2.0 A
  - 20 mΩ, V<sub>DD</sub> = 5 V, V<sub>D</sub> = 1 V
  - 27.5 mΩ, V<sub>DD</sub> = 3.3 V, V<sub>D</sub> = 1 V
- Pb-Free / Halogen-Free / RoHS compliant
- Operating Temperature: -40 °C to 85°C
- Operating Voltage: 2.5 V to 5.5 V
- Power Rail Switching V<sub>D</sub> = 0.85 V to V<sub>D</sub> = V<sub>DD</sub> - 1.5 V

### Pin Configuration

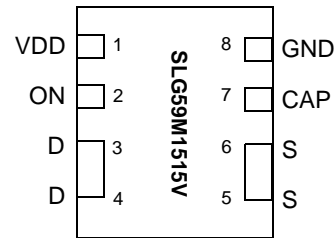

**8-pin STDFN**  
(Top View)

### Applications

- Fast Turn On/Off power rail switching with big Cap loading
- Frequent wake & sleep power cycle
- Mobile devices and portable devices

### Block Diagram

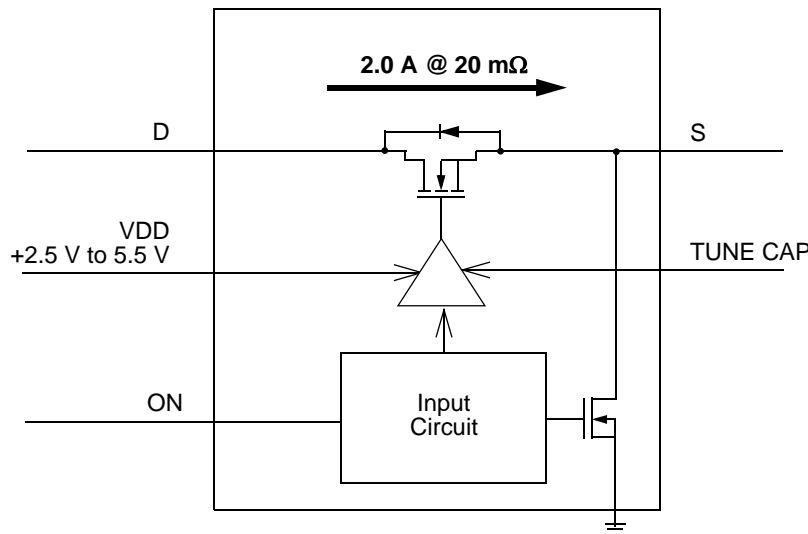



### Pin Description

Pin #	Pin Name	Type	Pin Description
1	VDD	PWR	VDD power for power switch control (2.5 V to 5.5 V)
2	ON	Input	Turns MOSFET ON (4 M $\Omega$ pull down resistor) CMOS input with VIL < 0.3 V, VIH > 0.85 V
3	D	MOSFET	Drain of Power MOSFET (fused with pin 4)
4	D	MOSFET	Drain of Power MOSFET (fused with pin 3)
5	S	MOSFET	Source of Power MOSFET (fused with pin 6)
6	S	MOSFET	Source of Power MOSFET (fused with pin 5)
7	CAP	CAP	Tuning Cap
8	GND	GND	Ground

### Ordering Information

Part Number	Type	Production Flow
SLG59M1515V	STDFN 8L	Industrial, -40 °C to 85 °C
SLG59M1515VTR	STDFN 8L (Tape and Reel)	Industrial, -40 °C to 85 °C



## Absolute Maximum Ratings

Parameter	Description	Conditions	Min.	Typ.	Max.	Unit
$V_{DD}$	Power Supply		--	--	7	V
$T_S$	Storage Temperature		-65	--	150	°C
$ESD_{HBM}$	ESD Protection	Human Body Model	2000	--	--	V
$W_{DIS}$	Package Power Dissipation		--	--	0.4	W
MOSFET $IDS_{PK}$	Peak Current from Drain to Source	For no more than 20 $\mu$ s with 1% duty cycle	--	--	25.0	A
		For no more than 50 $\mu$ s with 1% duty cycle	--	--	12.5	A
		For no more than 1 ms with 1% duty cycle	--	--	3.5	A

Note: Stresses greater than those listed under "Absolute Maximum Ratings" may cause permanent damage to the device. This is a stress rating only and functional operation of the device at these or any other conditions above those indicated in the operational sections of this specification is not implied. Exposure to absolute maximum rating conditions for extended periods may affect reliability.

## Electrical Characteristics

$T_A = -40\text{ }^\circ\text{C}$  to  $85\text{ }^\circ\text{C}$  (unless otherwise stated)

Parameter	Description	Conditions	Min.	Typ.	Max.	Unit
$V_{DD}$	Power Supply Voltage	$-40\text{ }^\circ\text{C}$ to $85\text{ }^\circ\text{C}$	2.5	--	5.5	V
$I_{DD}$	Power Supply Current (PIN 1)	when OFF	--	--	1	$\mu$ A
		when ON, No load	--	--	10	$\mu$ A
$R_{DS_{ON}}$	Static Drain to Source ON Resistance, $T_A = 25\text{ }^\circ\text{C}$	$V_{DD} = 5\text{ V}, V_D = 1.05\text{ V}, V_{DD} - V_D = 4.0\text{ V}, R_L = 0.5\ \Omega$	--	20	22	m $\Omega$
		$V_{DD} = 3.3\text{ V}, V_D = 1.05\text{ V}, V_{DD} - V_D = 2.3\text{ V}, R_L = 0.5\ \Omega$	--	27.5	29	m $\Omega$
	Static Drain to Source ON Resistance, $T_A = 70\text{ }^\circ\text{C}$	$V_{DD} = 5\text{ V}, V_D = 1.05\text{ V}, V_{DD} - V_D = 4.0\text{ V}, R_L = 0.5\ \Omega$	--	23.5	25	m $\Omega$
		$V_{DD} = 3.3\text{ V}, V_D = 1.05\text{ V}, V_{DD} - V_D = 2.3\text{ V}, R_L = 0.5\ \Omega$	--	31	33	m $\Omega$
	Static Drain to Source ON Resistance, $T_A = 85\text{ }^\circ\text{C}$	$V_{DD} = 5\text{ V}, V_D = 1.05\text{ V}, V_{DD} - V_D = 4.0\text{ V}, R_L = 0.5\ \Omega$	--	24.5	26	m $\Omega$
		$V_{DD} = 3.3\text{ V}, V_D = 1.05\text{ V}, V_{DD} - V_D = 2.3\text{ V}, R_L = 0.5\ \Omega$	--	33	35	m $\Omega$
$IDS$	Operating Current	$V_D = 0.85\text{ V}$ to $3.3\text{ V}$	--	--	2.0	A
$V_D$	Drain Voltage		0.85	--	$V_{DD} - 1.5$	V
$T_{ON\_Delay}$	ON Delay Time	50% ON to 10% $V_S$ , Internal Logic Delay, $V_{DD} = 5\text{ V}, V_D = 1.05\text{ V}$ , Tune Cap = 0.1 nF	--	12	15	$\mu$ s
		50% ON to 10% $V_S$ , Internal Logic Delay, $V_{DD} = 5\text{ V}, V_D = 1.05\text{ V}$ , Tune Cap = 0.5 nF	--	32	35	$\mu$ s



T<sub>A</sub> = -40 °C to 85 °C (unless otherwise stated)

Parameter	Description	Conditions	Min.	Typ.	Max.	Unit
T <sub>Total_ON</sub>	Total Turn On Time	50% ON to 90% V <sub>S</sub>	Configurable			
		50% ON to 90% V <sub>S</sub> , V <sub>DD</sub> = 5 V, V <sub>D</sub> = 1.0 V, C <sub>L</sub> = 1 μF, Current Load = 50 mA, Tune Cap = 0.1 nF	--	32	39	μs
		50% ON to 90% V <sub>S</sub> , V <sub>DD</sub> = 5 V, V <sub>D</sub> = 1.0 V, C <sub>L</sub> = 1 μF, Current Load = 100 mA, Tune Cap = 0.1 nF	--	32	39	μs
		50% ON to 90% V <sub>S</sub> , V <sub>DD</sub> = 5 V, V <sub>D</sub> = 1.0 V, C <sub>L</sub> = 4.7 μF, Current Load = 2.5 A, Tune Cap = 0.5 nF	--	102	123	μs
		50% ON to 90% V <sub>S</sub> , V <sub>DD</sub> = 5 V, V <sub>D</sub> = 1.0 V, C <sub>L</sub> = 10 μF, Current Load = 2.5 A, Tune Cap = 0.5 nF	--	102	123	μs
T <sub>SLEWRATE</sub>	Slew Rate	10% V <sub>S</sub> to 90% V <sub>S</sub>	Configurable			
		10% V <sub>S</sub> to 90% V <sub>S</sub> , V <sub>DD</sub> = 5 V, V <sub>D</sub> = 1.0 V, C <sub>L</sub> = 1 μF, Current Load = 50 mA, Tune Cap = 0.1 nF	--	65	78	V/ms
		10% V <sub>S</sub> to 90% V <sub>S</sub> , V <sub>DD</sub> = 5 V, V <sub>D</sub> = 1.0 V, C <sub>L</sub> = 1 μF, Current Load = 100 mA, Tune Cap = 0.1 nF	--	65	78	V/ms
		10% V <sub>S</sub> to 90% V <sub>S</sub> , V <sub>DD</sub> = 5 V, V <sub>D</sub> = 1.0 V, C <sub>L</sub> = 4.7 μF, Current Load = 2.5 A, Tune Cap = 0.5 nF	--	13	16	V/ms
		10% V <sub>S</sub> to 90% V <sub>S</sub> , V <sub>DD</sub> = 5 V, V <sub>D</sub> = 1.0 V, C <sub>L</sub> = 10 μF, Current Load = 2.5 A, Tune Cap = 0.5 nF	--	13.5	16.5	V/ms
CAP <sub>SOURCE</sub>	Source Cap	Source to GND	--	--	10	μF
R <sub>DIS</sub>	Discharge Resistance		100	150	300	Ω
ON_V <sub>IH</sub>	High Input Voltage on ON pin		0.85	--	V <sub>DD</sub>	V
ON_V <sub>IL</sub>	Low Input Voltage on ON pin		-0.3	0	0.3	V
T <sub>OFF_Delay</sub>	OFF Delay Time	50% ON to V <sub>S</sub> Fall, C <sub>L</sub> = 10 μF, R <sub>L</sub> = 20 Ω, V <sub>DD</sub> = 5 V, V <sub>D</sub> = 1.0 V, No Tune CAP	--	120	150	μs
THERM_OFF	Thermal Protection Shutoff	Programmable, automatic shutoff temperature	--	125	--	°C
THERM_OFF_ACC	Thermal Sensor Accuracy		--	--	±20	%
THERM_DT	Thermal Disable Time	Thermal sensor disable for the ON rising edge to 100 μs. Prevent therm shutdown from inrush current	--	--	100	μs



### Tune Cap vs Slew Rate

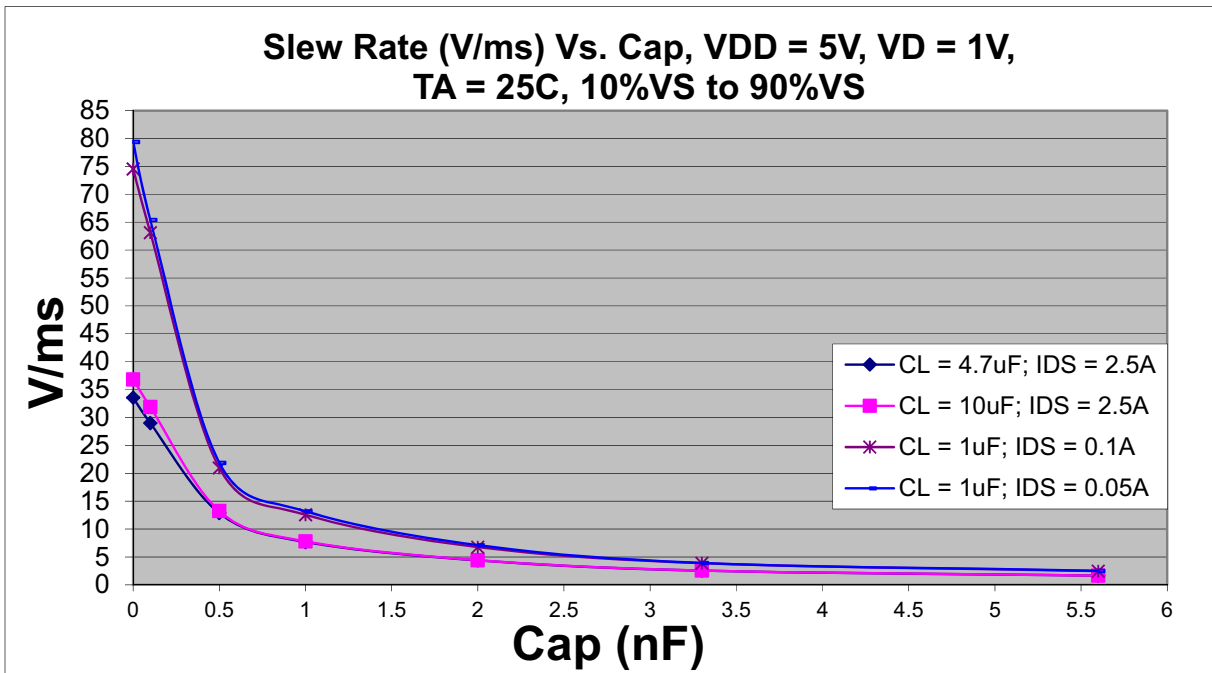

### Tune Cap vs Ttotal\_on

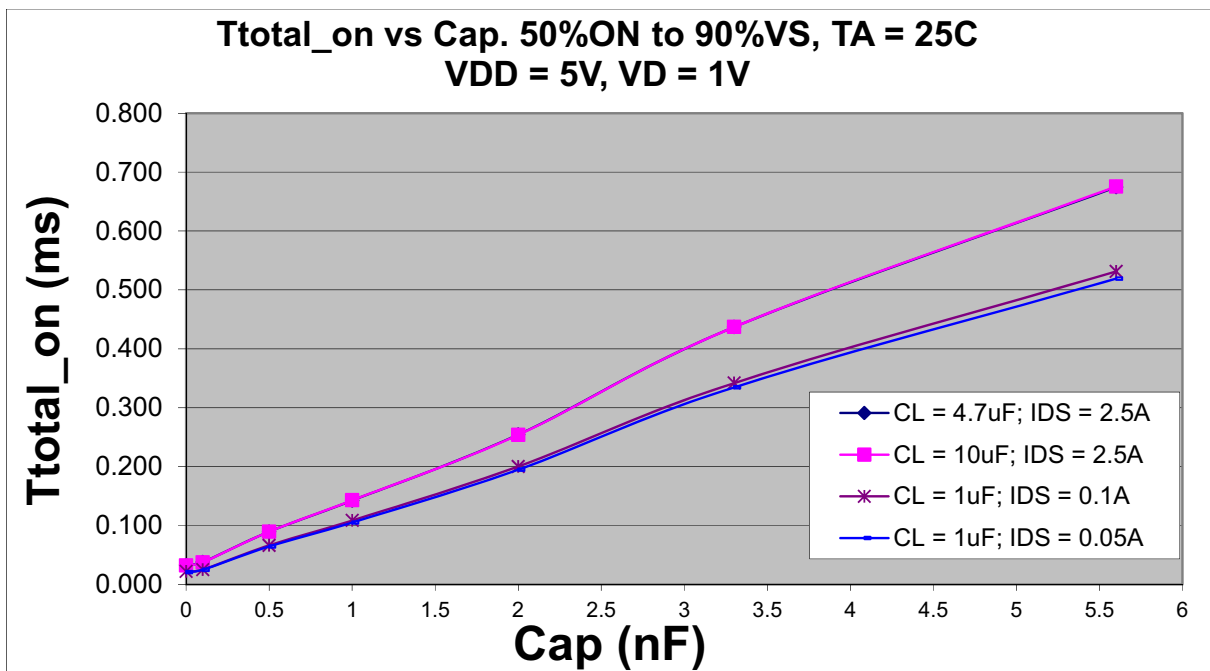



### $T_{Total\_ON}$ , $T_{ON\_Delay}$ and Slew Rate Measurement (TBD)

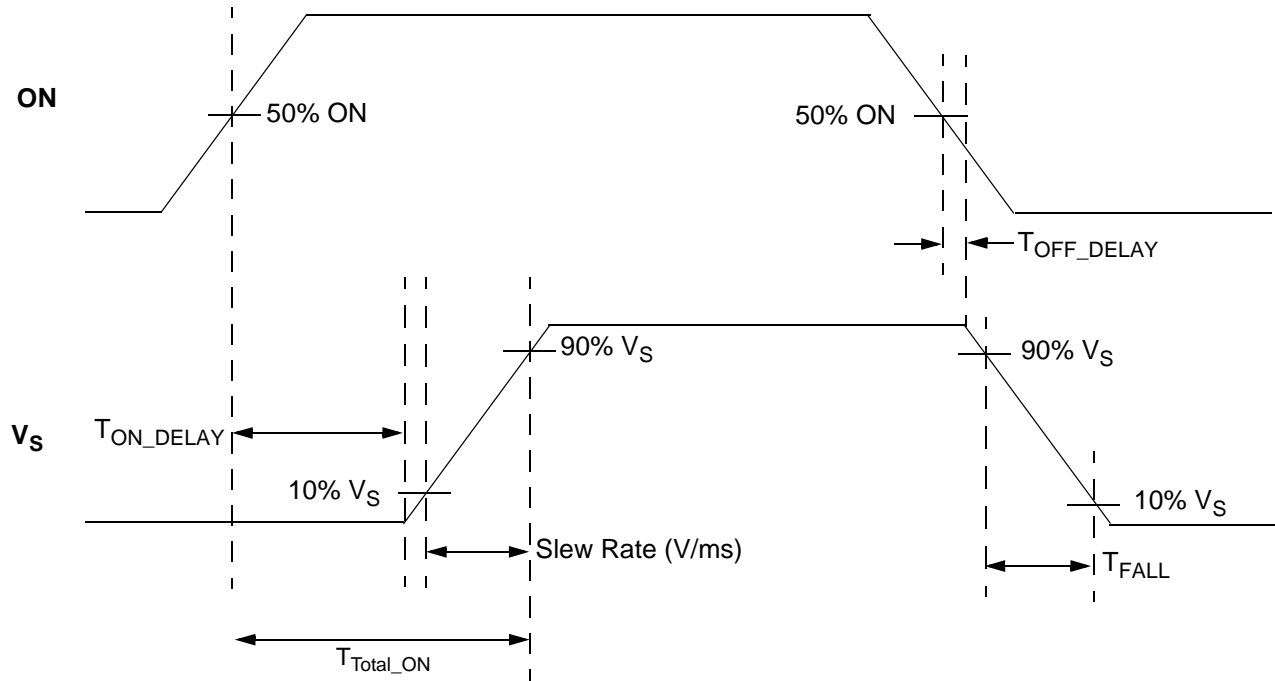



---

Package Top Marking System Definition

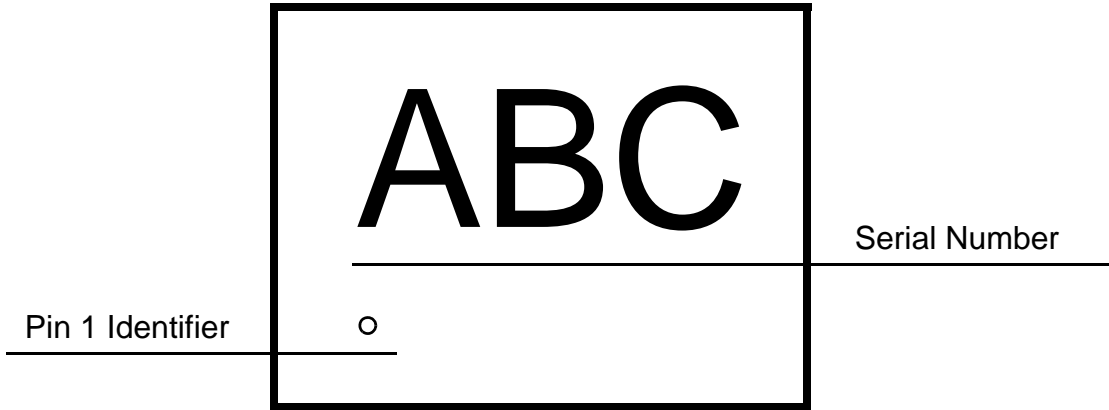



### Package Drawing and Dimensions

8 Lead STDFN Package 1.0 x 1.6 mm (Fused Lead)

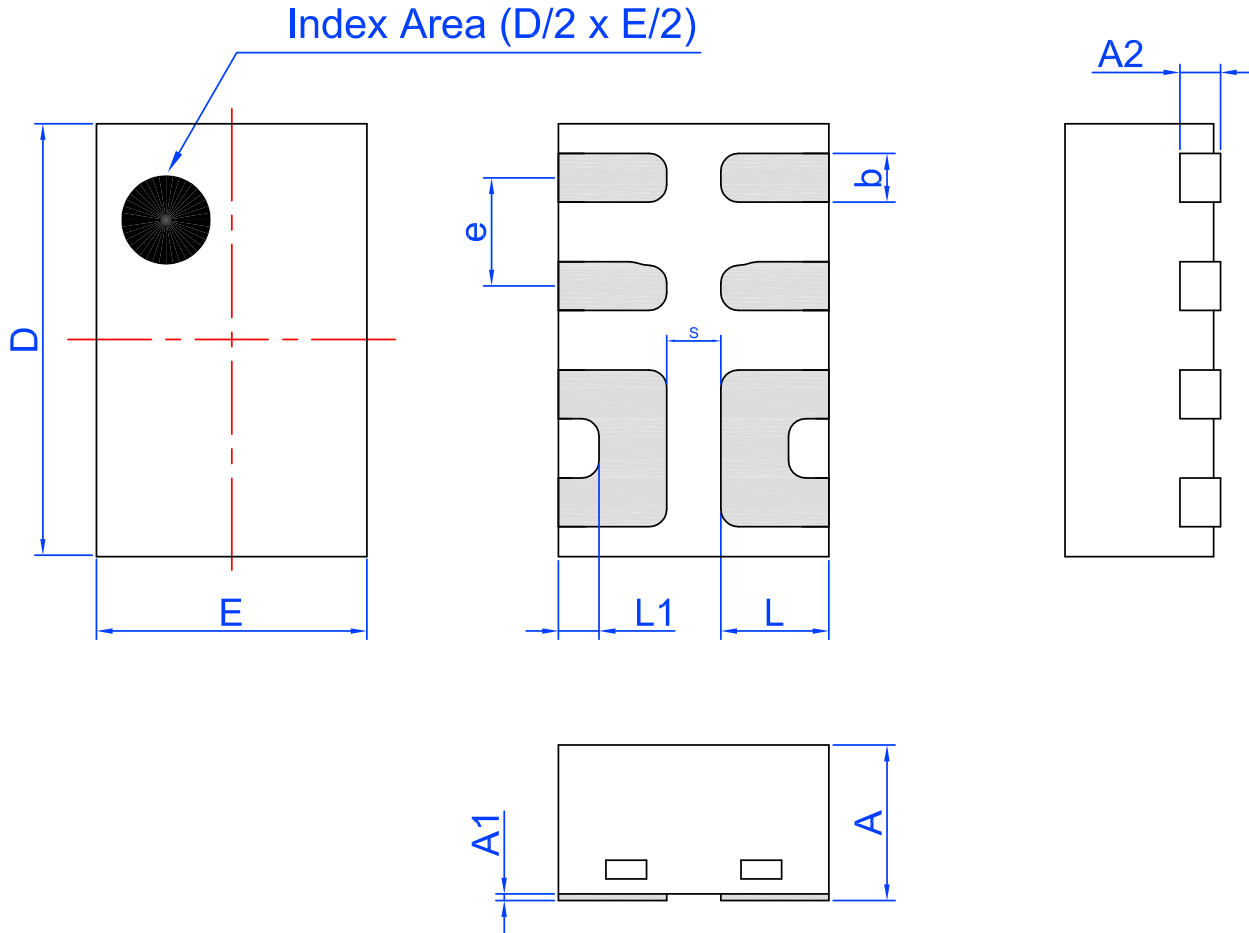

Unit: mm

Symbol	Min	Nom.	Max	Symbol	Min	Nom.	Max
A	0.50	0.55	0.60	D	1.55	1.60	1.65
A1	0.005	-	0.060	E	0.95	1.00	1.05
A2	0.10	0.15	0.20	L	0.35	0.40	0.45
b	0.13	0.18	0.23	L1	0.10	0.15	0.20
e	0.40 BSC			S	0.2 REF		





**Tape and Reel Specifications**

Package Type	# of Pins	Nominal Package Size [mm]	Max Units		Reel & Hub Size [mm]	Leader (min)		Trailer (min)		Tape Width [mm]	Part Pitch [mm]
			per Reel	per Box		Pockets	Length [mm]	Pockets	Length [mm]		
STDFN 8L 1x1.6mm 0.4P FC Green	8	1.0 x 1.6 x 0.55	3,000	3,000	178 / 60	100	400	100	400	8	4

**Carrier Tape Drawing and Dimensions**

Package Type	Pocket BTM Length	Pocket BTM Width	Pocket Depth	Index Hole Pitch	Pocket Pitch	Index Hole Diameter	Index Hole to Tape Edge	Index Hole to Pocket Center	Tape Width
	A0	B0	K0	P0	P1	D0	E	F	W
STDFN 8L 1x1.6mm 0.4P FC Green	1.12	1.72	0.7	4	4	1.55	1.75	3.5	8

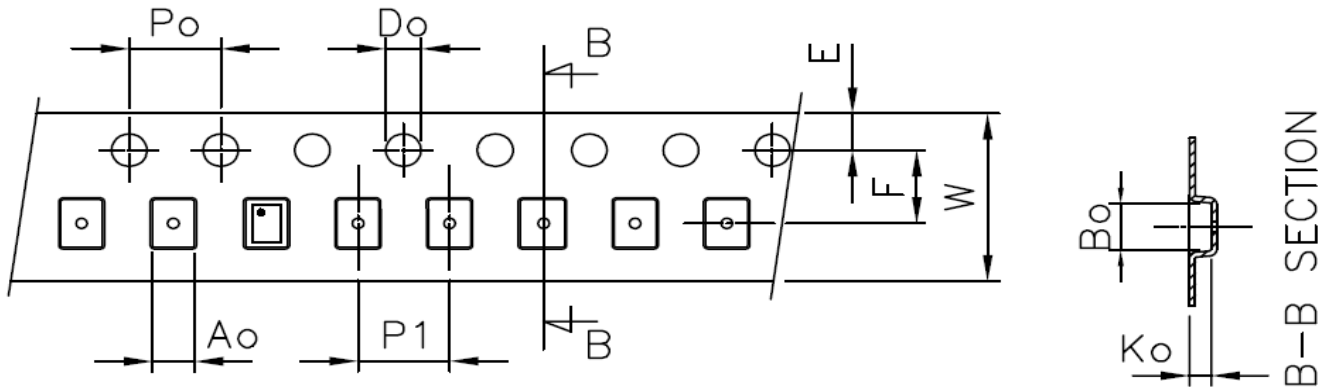

**Recommended Reflow Soldering Profile**

Please see IPC/JEDEC J-STD-020: latest revision for reflow profile based on package volume of 0.88 mm<sup>3</sup> (nominal). More information can be found at [www.jedec.org](http://www.jedec.org).



Компания «ЭлектроПласт» предлагает заключение долгосрочных отношений при поставках импортных электронных компонентов на взаимовыгодных условиях!

Наши преимущества:

- Оперативные поставки широкого спектра электронных компонентов отечественного и импортного производства напрямую от производителей и с крупнейших мировых складов;
- Поставка более 17-ти миллионов наименований электронных компонентов;
- Поставка сложных, дефицитных, либо снятых с производства позиций;
- Оперативные сроки поставки под заказ (от 5 рабочих дней);
- Экспресс доставка в любую точку России;
- Техническая поддержка проекта, помощь в подборе аналогов, поставка прототипов;
- Система менеджмента качества сертифицирована по Международному стандарту ISO 9001;
- Лицензия ФСБ на осуществление работ с использованием сведений, составляющих государственную тайну;
- Поставка специализированных компонентов (Xilinx, Altera, Analog Devices, Intersil, Interpoint, Microsemi, Aeroflex, Peregrine, Syfer, Eurofarad, Texas Instrument, Miteq, Cobham, E2V, MA-COM, Hittite, Mini-Circuits, General Dynamics и др.);

Помимо этого, одним из направлений компании «ЭлектроПласт» является направление «Источники питания». Мы предлагаем Вам помощь Конструкторского отдела:

- Подбор оптимального решения, техническое обоснование при выборе компонента;
- Подбор аналогов;
- Консультации по применению компонента;
- Поставка образцов и прототипов;
- Техническая поддержка проекта;
- Защита от снятия компонента с производства.



#### Как с нами связаться

**Телефон:** 8 (812) 309 58 32 (многоканальный)

**Факс:** 8 (812) 320-02-42

**Электронная почта:** [org@eplast1.ru](mailto:org@eplast1.ru)

**Адрес:** 198099, г. Санкт-Петербург, ул. Калинина, дом 2, корпус 4, литера А.