

**RECEPTACLE**

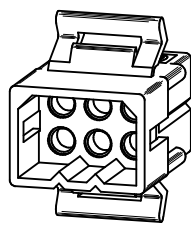

**PLUG**

<b>UPDATE REV. LEVEL</b> EC NO: UCP2011-1525 DRWN: AELHAG 2010/11/23 CHKD: JBELL 2010/11/24 APPR: FSMITH 2010/12/03 X4	<b>DESCRIPTION</b> QUALITY SYMBOLS ▽=0 ▽=0	<b>GENERAL TOLERANCES (UNLESS SPECIFIED)</b>		<b>DIMENSION STYLE</b> IN/MM	<b>SCALE</b> 2:1	<b>DESIGN UNITS</b> INCH	THIRD ANGLE PROJECTION	
		4 PLACES ± --- ± --- 3 PLACES ± --- ± .007 2 PLACES ± 0.18 ± 0.10 1 PLACE ± 0.25 ± ---	mm INCH DRAWN BY DATE AELHAG 2010/11/23 CHECKED BY DATE JBELL 2010/11/24 APPROVED BY DATE FSMITH 2010/12/03	TITLE .093/(2.36) HOUSING, PLUG AND RECEPTACLE, 6 CKT., .198/(5.03)CTRS.				
		ANGULAR ± 2 °		MATERIAL NO. <b>SEE CHART</b>		DOCUMENT NO. SD-1261-*		SHEET NO. 1 OF 2
		DRAFT WHERE APPLICABLE MUST REMAIN WITHIN DIMENSIONS		MOLEX INCORPORATED THIS DRAWING CONTAINS INFORMATION THAT IS PROPRIETARY TO MOLEX INCORPORATED AND SHOULD NOT BE USED WITHOUT WRITTEN PERMISSION				

PLUG	
PART NO.	ENG. NO.
03-09-2061	I261-P
23-09-2061	I261-P-100
03-09-2062	I261-P1
23-09-2062	I261-P1-100
03-09-7061	I261-PBK
03-09-7062	I261-PIBK
27-09-2093	I261-P1-200

RECEPTACLE	
PART NO.	ENG. NO.
03-09-1061	I261-R
23-09-1061	I261-R-100
03-09-1062	I261-R1
23-09-1062	I261-R1-100
03-09-1063	I261-R2
23-09-1063	I261-R2-100
03-09-1064	I261-R3
27-09-1063	I261-R2-200
03-09-6064	I261-R3BK
03-09-6063	I261-R2BK
03-09-6062	I261-R1BK
03-09-6061	I261-RBK

**LEGEND: PLUG**

I261-P\*\*\*-\*\*\*  
 P = PLUG  
 I = PLUG WITHOUT MOUNTING EARS  
 BLANK = PLUG WITH PREBENT MOUNTING EARS  
 COLOR: BLANK=NATURAL COLOR  
 AM=AMBER BK=BLACK BU=BLUE  
 BN=BROWN GY=GRAY GN=GREEN  
 OR=ORANGE RD=RED YW=YELLOW  
 MATERIAL: BLANK = NYLON 6/6, U.L. 94V-2  
 100 = POLYPROPYLENE, U.L. 94V-0  
 200 = NYLON 6/6, U.L. 94V-0, RED

**LEGEND: RECEPTACLE**

I261-R\*\*\*-\*\*\*  
 R = RECEPTACLE  
 BLANK = WITH STD. MOUNTING EARS, WITH LOCK RAMPS  
 1 = WITH STD. MOUNTING EARS, WITHOUT LOCK RAMPS  
 2 = WITHOUT MOUNTING EARS, WITHOUT LOCK RAMPS  
 3 = WITHOUT MOUNTING EARS, WITH LOCK RAMPS  
 4 = WITH PREBENT MOUNTING EARS, WITH LOCK RAMPS  
 5 = WITH PREBENT MOUNTING EARS, WITHOUT LOCK RAMPS  
 COLOR: BLANK=NATURAL COLOR  
 AM=AMBER BK=BLACK BU=BLUE  
 BN=BROWN GY=GRAY GN=GREEN  
 OR=ORANGE RD=RED YW=YELLOW  
 MATERIAL: BLANK = NYLON 6/6, U.L. 94V-2  
 100 = POLYPROPYLENE, U.L. 94V-0  
 200 = NYLON 6/6, U.L. 94V-0, RED

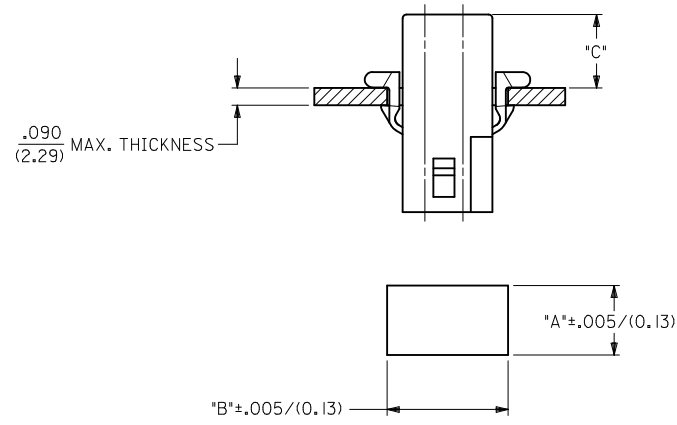

HOUSING	DIM. "A"	DIM. "B"	DIM. "C" (STD. EAR)	DIM. "C" (PREBENT)
PLUG	.750/(19.05)	.695/(17.65)	.39/(9.9)	.40/(10.1)
RECEPTACLE	.718/(18.24)	.600/(15.24)	.40/(10.1)	.41/(10.3)

MOUNTING HOLE CUTOUT

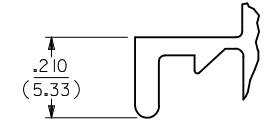

**DETAIL 3**  
 .093/(2.36) STANDARD MOUNTING EAR  
 (SCALE 4:1)

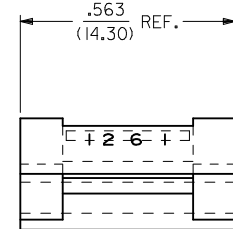

**DETAIL 4**  
 .093/(2.36)PREBENT MOUNTING EAR  
 (SCALE 4:1)

**NOTES:**

- MATERIAL: SEE LEGEND
- FINISH: NONE.
- PRODUCT SPECIFICATION: PS-43660-9999
- PACKAGING INFORMATION: PK-1261-001
- HOUSINGS FOR USE WITH MOLEX .093/(2.36) PIN AND SOCKET TERMINALS.
- CIRCUIT I.D. NUMBERS ON SIDE OF HOUSING APPEAR ON PARTS FROM TOOLS BUILT AFTER 9/3/91.
- WHERE DENOTED IN CHART, TOOLS ARE BUILT WITH PREBENT MOUNTING EARS PER DETAIL 4 AND SUPERSEDE ALL TOOLS PREVIOUSLY BUILT WITH THE STANDARD MOUNTING EAR.
- TEXT AND CIRCUIT IDENTIFIERS ARE SHOWN IN APPROXIMATE LOCATION BUT MAY VARY TO ACCOMMODATE TOOLING.

DEL. UV MAT'L & P/N EC NO: UCP2011-1525 DRWN: AELHAG 2010/11/23 CHKD: JBELL 2010/11/24 APPR: FSMITH 2010/12/03	QUALITY SYMBOLS = 0 = 0	GENERAL TOLERANCES (UNLESS SPECIFIED)		DIMENSION STYLE <b>IN/MM</b>		SCALE <b>4:1</b>	DESIGN UNITS <b>INCH</b>	THIRD ANGLE PROJECTION	
		4 PLACES ± --- ± ---	3 PLACES ± --- ± .007	DRAWN BY AELHAG	DATE 2010/11/23	TITLE <b>.093/(2.36) HOUSING, PLUG AND RECEPTACLE, 6 CKT., .198/(5.03)CTRS.</b>			
		2 PLACES ± 0.18 ± .010	1 PLACE ± 0.25 ± ---	CHECKED BY JBELL	DATE 2010/11/24	MOLEX INCORPORATED			
		ANGULAR ± 2 °		APPROVED BY FSMITH	DATE 2010/12/03	MATERIAL NO. <b>SEE CHART</b>		DOCUMENT NO. <b>SD-1261-*</b>	SHEET NO. <b>2 OF 2</b>
DRAFT WHERE APPLICABLE MUST REMAIN WITHIN DIMENSIONS		SIZE 		THIS DRAWING CONTAINS INFORMATION THAT IS PROPRIETARY TO MOLEX INCORPORATED AND SHOULD NOT BE USED WITHOUT WRITTEN PERMISSION					



Компания «ЭлектроПласт» предлагает заключение долгосрочных отношений при поставках импортных электронных компонентов на взаимовыгодных условиях!

Наши преимущества:

- Оперативные поставки широкого спектра электронных компонентов отечественного и импортного производства напрямую от производителей и с крупнейших мировых складов;
- Поставка более 17-ти миллионов наименований электронных компонентов;
- Поставка сложных, дефицитных, либо снятых с производства позиций;
- Оперативные сроки поставки под заказ (от 5 рабочих дней);
- Экспресс доставка в любую точку России;
- Техническая поддержка проекта, помощь в подборе аналогов, поставка прототипов;
- Система менеджмента качества сертифицирована по Международному стандарту ISO 9001;
- Лицензия ФСБ на осуществление работ с использованием сведений, составляющих государственную тайну;
- Поставка специализированных компонентов (Xilinx, Altera, Analog Devices, Intersil, Interpoint, Microsemi, Aeroflex, Peregrine, Syfer, Eurofarad, Texas Instrument, Miteq, Cobham, E2V, MA-COM, Hittite, Mini-Circuits, General Dynamics и др.);

Помимо этого, одним из направлений компании «ЭлектроПласт» является направление «Источники питания». Мы предлагаем Вам помощь Конструкторского отдела:

- Подбор оптимального решения, техническое обоснование при выборе компонента;
- Подбор аналогов;
- Консультации по применению компонента;
- Поставка образцов и прототипов;
- Техническая поддержка проекта;
- Защита от снятия компонента с производства.



#### Как с нами связаться

**Телефон:** 8 (812) 309 58 32 (многоканальный)

**Факс:** 8 (812) 320-02-42

**Электронная почта:** [org@eplast1.ru](mailto:org@eplast1.ru)

**Адрес:** 198099, г. Санкт-Петербург, ул. Калинина, дом 2, корпус 4, литера А.