

OUTPUT COUPLING CAPACITOR-LESS VIDEO AMPLIFIER WITH COAXIAL COMMUNICATION RECEIVER

■ GENERAL DESCRIPTION

The NJU71042 is a Low Voltage Video Amplifier with Coaxial Communication Receiver. By the internal charge pump circuit, output capacitor is unnecessary.

The NJU71042 features low power and small package, and is suitable for low power design on downsizing of portable video system and system with video output.

Moreover, the following voltage gain variations are arranged.

- NJU71041(Gain=6dB)

■ PACKAGE OUTLINE



NJU71042RB2
MSOP10(TVSP10)



NJU71042MJE
****U.D.**

■ FEATURES

- Operating Voltage 2.5 to 3.45V
- Output coupling capacitor-less
- Coaxial Communication Receiver
- 12dB amplifier
- Internal 75Ω Driver Circuit (2-system drive)
- Internal LPF -1dB at 10MHz typ
-40dB at 54MHz typ

- CMOS Technology
- Package Outline

MSOP10(TVSP10)*, EQFN12(3.0*3.0mm)**U.D.

*MEET JEDEC MO-187-DA / THIN TYPE

■ PIN CONFIGURATION

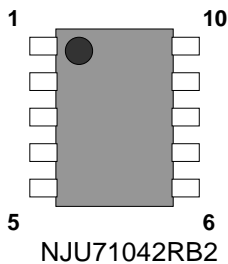

- 1: CP1
- 2: V+
- 3: VIN
- 4: UTCREF
- 5: UTCOUT
- 6: UTCIN
- 7: VOUT
- 8: GND
- 9: V-
- 10: CP2

■ BLOCK DIAGRAM

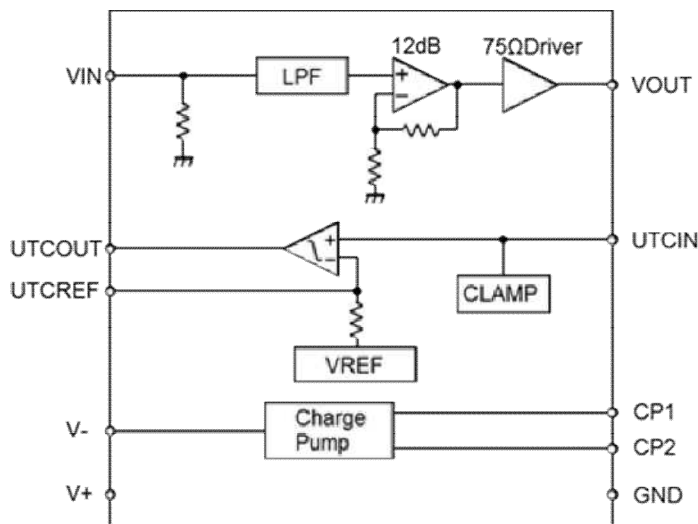

NJU71042

■ ABSOLUTE MAXIMUM RATINGS (Ta=25°C)

PARAMETER	SYMBOL	RATINGS	UNIT
Supply Voltage	V ⁺	3.55	V
Power Dissipation	P _D	MSOP10(TVSP10): 480(Note1)	mW
VIN Input Voltage (positive)	VIN+	+0.5	V
VIN Input Voltage (negative)	VIN-	-0.5	V
Operating Temperature Range	Topr	-40 to +85	°C
Storage Temperature Range	Tstg	-55 to +125	°C

(Note 1) At on a board of EIA/JEDEC specification. (114.3 x 76.2 x 1.6mm 2 layers, FR-4)

■ RECOMMENDED OPERATING CONDITION (Ta=25°C)

PARAMETER	SYMBOL	TEST CONDITION	MIN.	TYP.	MAX.	UNIT
Operating Voltage	Vopr		2.5	-	3.45	V

■ ELECTRICAL CHARACTERISTICS (V⁺=3.0V, R_L=150Ω, Ta=25°C)

PARAMETER	SYMBOL	TEST CONDITION	MIN.	TYP.	MAX.	UNIT
-----------	--------	----------------	------	------	------	------

◆ Power Supply

Operating Current	I _{CC}	No Signal	-	16	25	mA
-------------------	-----------------	-----------	---	----	----	----

◆ Video Amplifier Characteristics

Maximum Output Voltage Swing	V _{om}	f=100kHz, THD=1%	3.6	-	-	V _{p-p}
Voltage Gain	G _v	V _{in} =100kHz, 0.5V _{p-p} , Input Sine Signal	11.6	12.0	12.4	dB
Low Pass Filter Characteristic	G _f 6.75M	V _{in} =6.75MHz/100kHz, 0.5V _{p-p}	-1.0	0	1.0	dB
	G _f 10M	V _{in} =10MHz/100kHz, 0.5V _{p-p}	-	-1.0	-	
	G _f 54M	V _{in} =54MHz/100kHz, 0.5V _{p-p}	-	-35	-24	
Differential Gain	DG	V _{in} =0.5V _{p-p} , 10step Video Signal	-	0.8	-	%
Differential Phase	DP	V _{in} =0.5V _{p-p} , 10step Video Signal	-	0.5	-	deg
S/N Ratio	SN _v	100kHz to 6MHz, V _{in} =0.5V _{p-p} 100% White Video Signal, R _L =75Ω	-	+65	-	dB
Switching Noise Level	N _{swpl}	R _L =75Ω, 10% White Video Signal Input	-	4	7	mV _{pp}

◆ Coaxial Communication Receiver Characteristics

Data Threshold Voltage	V _{th}		-	0.65	-	V
Data Output Voltage High Level	VOH		2.7	-	-	V
Data Output Voltage Low Level	VOL		-		0.3	

■ TEST CIRCUIT

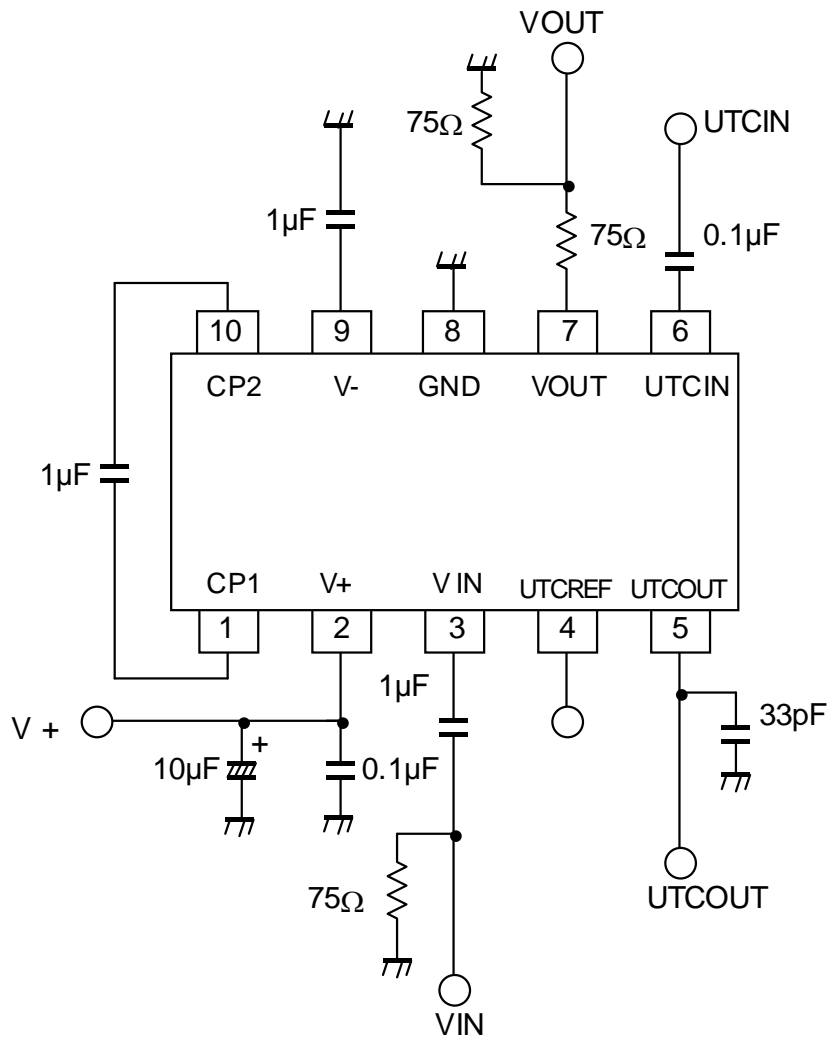

NJU71042

■ APPLICATION CIRCUIT 1 (Standard circuit)

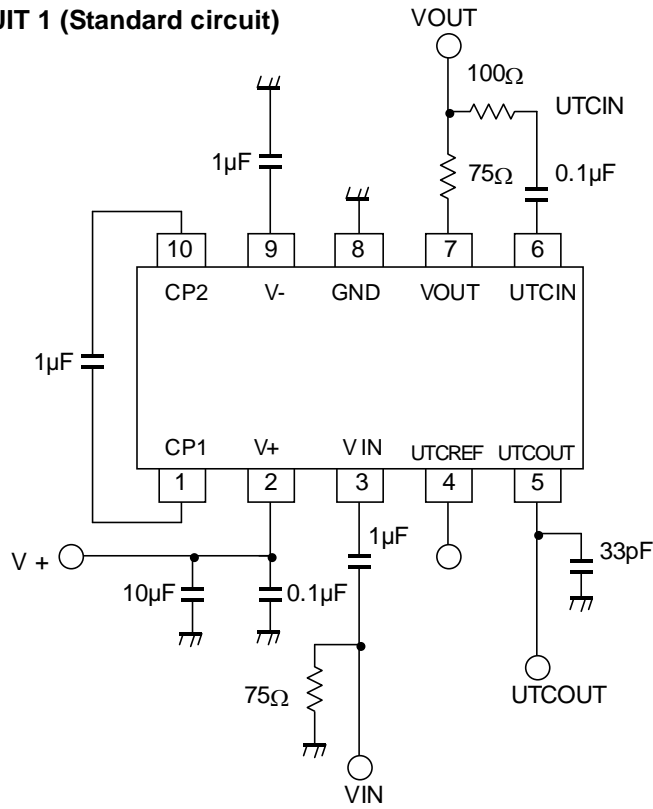

■ APPLICATION CIRCUIT 2 (Two-line drive circuit)

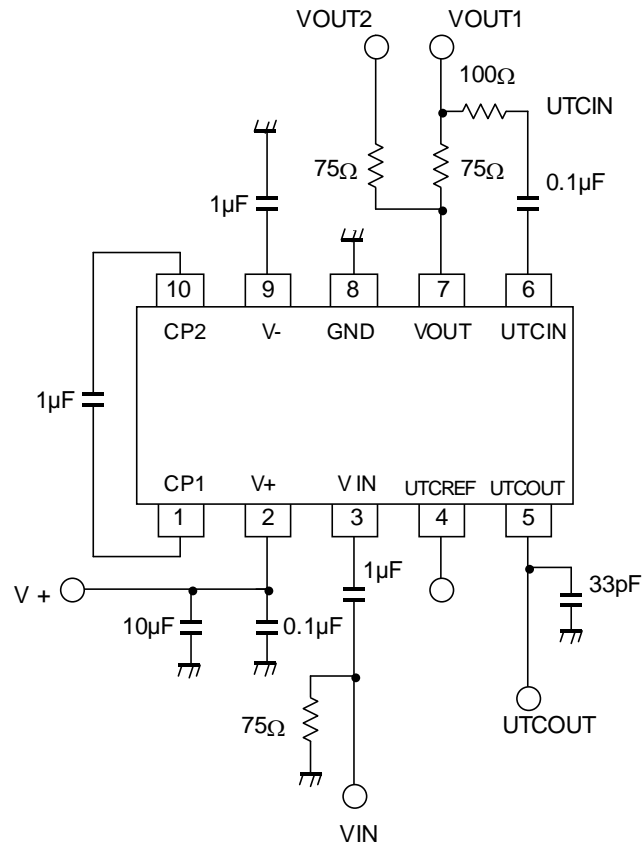

■ Application Note

• The UTC receiver block (UTCIN (pin6), UTCOUT (pin5), UTCREF (pin4))

The NJU71042 can transmit that video signal and camera control signal at one coaxial cable.

The output video signal from the NJU71042 superimposes on a camera control signal (a coaxial data from an output unit).

The output unit examples are DVR, camera-controller, and so on.

The superimposed signal is inputted to the NJU71042 UTCIN (pin 6). Refer to fig1.

The signal inputted to UTCIN (pin6) is compared to the reference voltage generated by the NJU71042.

After that, it is amplified and outputted the high (V+)/low (0V) signal from UTCOUT (pin5).

(The UTCREF (pin4) can set the threshold voltage of the comparator by the pull-down or the pull up resistor. Refer to fig3.)

The signal outputted from UTCOUT (pin5) is inputted to a camera control block of CCTV.

As above mentioned, the video signal and the camera control signal can transmit at one coaxial cable.

Therefore, The NJU71042 contributes to the space - saving.

A case of multiple coaxial transmission: UTC(Up The Coaxial)

This is one of a case at the multiplex coaxial transmission used in CCTV.

It is a system that control signals of camera multiplexing to the coaxial cable.

This system is superimposed on the control signal pulse in the vertical blanking period as shown in Figure.

This is because do not affect the video signal.

Case of Coaxitron

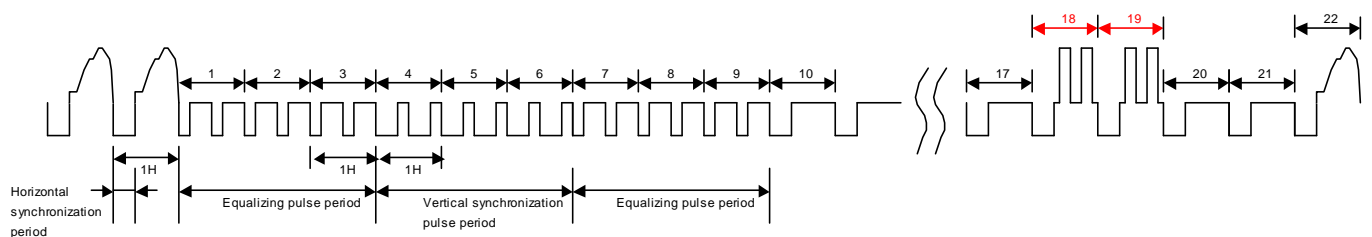

Figure: A case of UTC

• Application flow about the UTC receiver of the NJU71042

1. The output-signal from VOUT (pin7) superimposes a camera control signal by a camera control unit.
(The superimposed signal is inputted to the camera output block.)
2. The superimposed signal is inputted to UTCIN (pin6).
3. Its signal is clamped on sync-tip to reference voltage.
4. The clamped signal is amplified two times. After that, its signal is passed through comparator, and converted to high level (V+) or low level (0V). And then, the converted signal is outputted from UTCOUT (pin5).
5. The outputted signal from UTCOUT (pin5) is inputted to CCTV' s camera control unit.

Note) The control signal cannot use 2-system drive. Refer to Fig2.

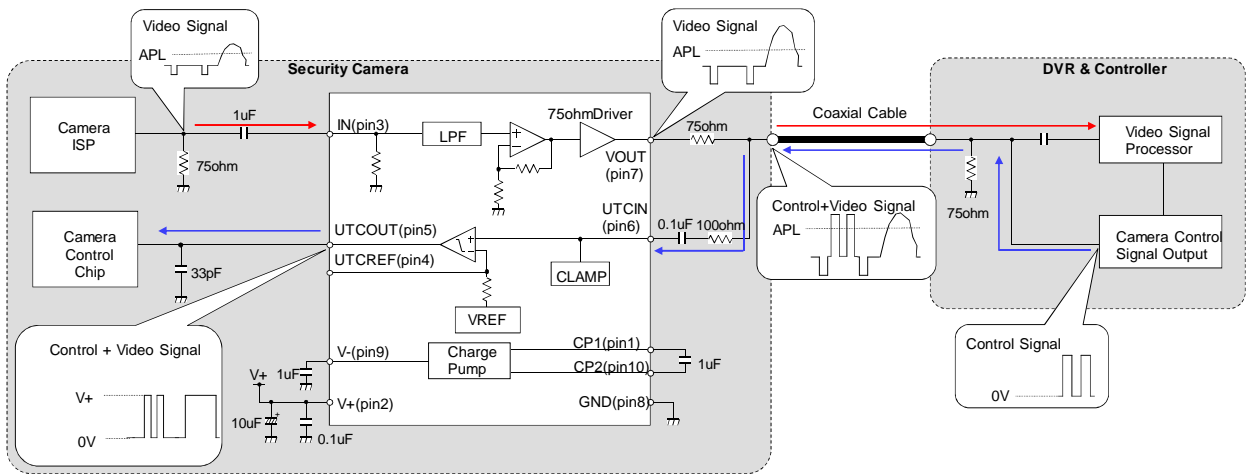

Fig.1: Application of UTC

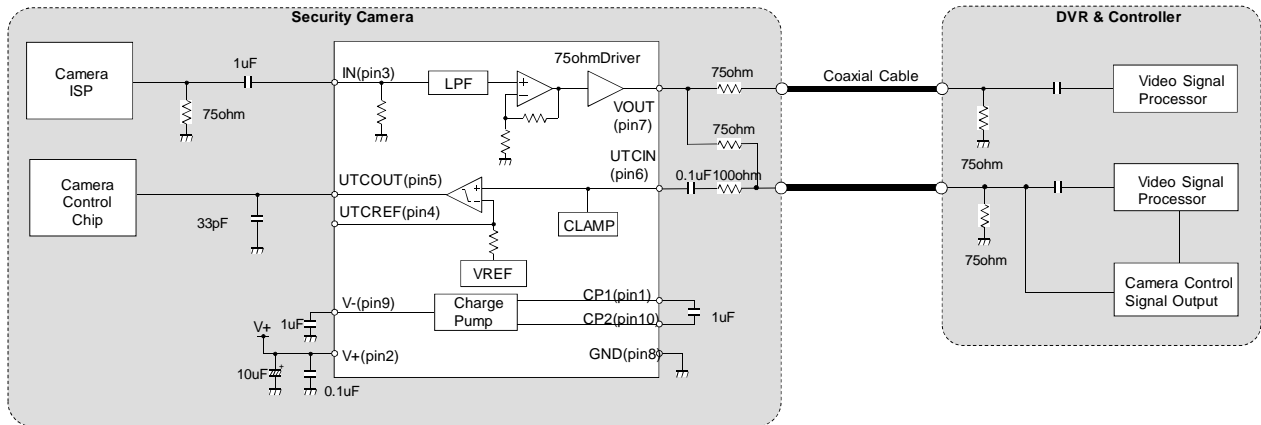

Fig.2: 2 - system drive application

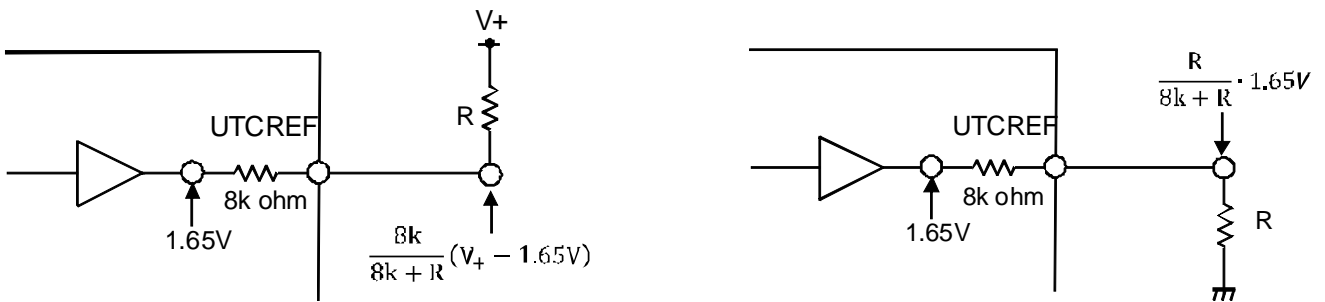

Fig.3: setting method (pull – up, pull – down resistor) of UTCREF

■ TERMINAL DISRIPTION

PIN No.	PIN NAME	FUNCTION	EQUIVALENT CIRCUIT	DC VOLTAGE
1	CP1	Flying Capacitor Terminal		-
2	V+	V+ Power Supply	-	-
3	VIN	Input for video signal		0V
4	UTC REF	Adjust terminal for reference voltage of comparator (UTC receiver)		1.65V
5	UTC OUT	Output for UTC receiver		-

■ TERMINAL DISCRIPTION

PIN No.	PIN NAME	FUNCTION	EQUIVALENT CIRCUIT	DC VOLTAGE
6	UTCIN	Input for UTC receiver		0.35V
7	VOUT	Output for video signal		0V
8	GND	ground	-	-
9	V-	V- power supply for charge-pump	-	-
10	CP2	Flying Capacitor Terminal		-

[CAUTION]
 The specifications on this databook are only given for information, without any guarantee as regards either mistakes or omissions. The application circuits in this databook are described only to show representative usages of the product and not intended for the guarantee or permission of any right

Mouser Electronics

Authorized Distributor

Click to View Pricing, Inventory, Delivery & Lifecycle Information:

[NJR:](#)

[NJU71042RB2-TE2](#)



Компания «ЭлектроПласт» предлагает заключение долгосрочных отношений при поставках импортных электронных компонентов на взаимовыгодных условиях!

Наши преимущества:

- Оперативные поставки широкого спектра электронных компонентов отечественного и импортного производства напрямую от производителей и с крупнейших мировых складов;
- Поставка более 17-ти миллионов наименований электронных компонентов;
- Поставка сложных, дефицитных, либо снятых с производства позиций;
- Оперативные сроки поставки под заказ (от 5 рабочих дней);
- Экспресс доставка в любую точку России;
- Техническая поддержка проекта, помощь в подборе аналогов, поставка прототипов;
- Система менеджмента качества сертифицирована по Международному стандарту ISO 9001;
- Лицензия ФСБ на осуществление работ с использованием сведений, составляющих государственную тайну;
- Поставка специализированных компонентов (Xilinx, Altera, Analog Devices, Intersil, Interpoint, Microsemi, Aeroflex, Peregrine, Syfer, Eurofarad, Texas Instrument, Miteq, Cobham, E2V, MA-COM, Hittite, Mini-Circuits, General Dynamics и др.);

Помимо этого, одним из направлений компании «ЭлектроПласт» является направление «Источники питания». Мы предлагаем Вам помощь Конструкторского отдела:

- Подбор оптимального решения, техническое обоснование при выборе компонента;
- Подбор аналогов;
- Консультации по применению компонента;
- Поставка образцов и прототипов;
- Техническая поддержка проекта;
- Защита от снятия компонента с производства.



Как с нами связаться

Телефон: 8 (812) 309 58 32 (многоканальный)

Факс: 8 (812) 320-02-42

Электронная почта: org@eplast1.ru

Адрес: 198099, г. Санкт-Петербург, ул. Калинина, дом 2, корпус 4, литера А.