

Jul.1.2019 Copyright 2019 HIROSE ELECTRIC CO., LTD. All Rights Reserved.  
 In case of consideration for using Automotive equipment / device which demand high reliability, kindly contact our sales window correspondents.

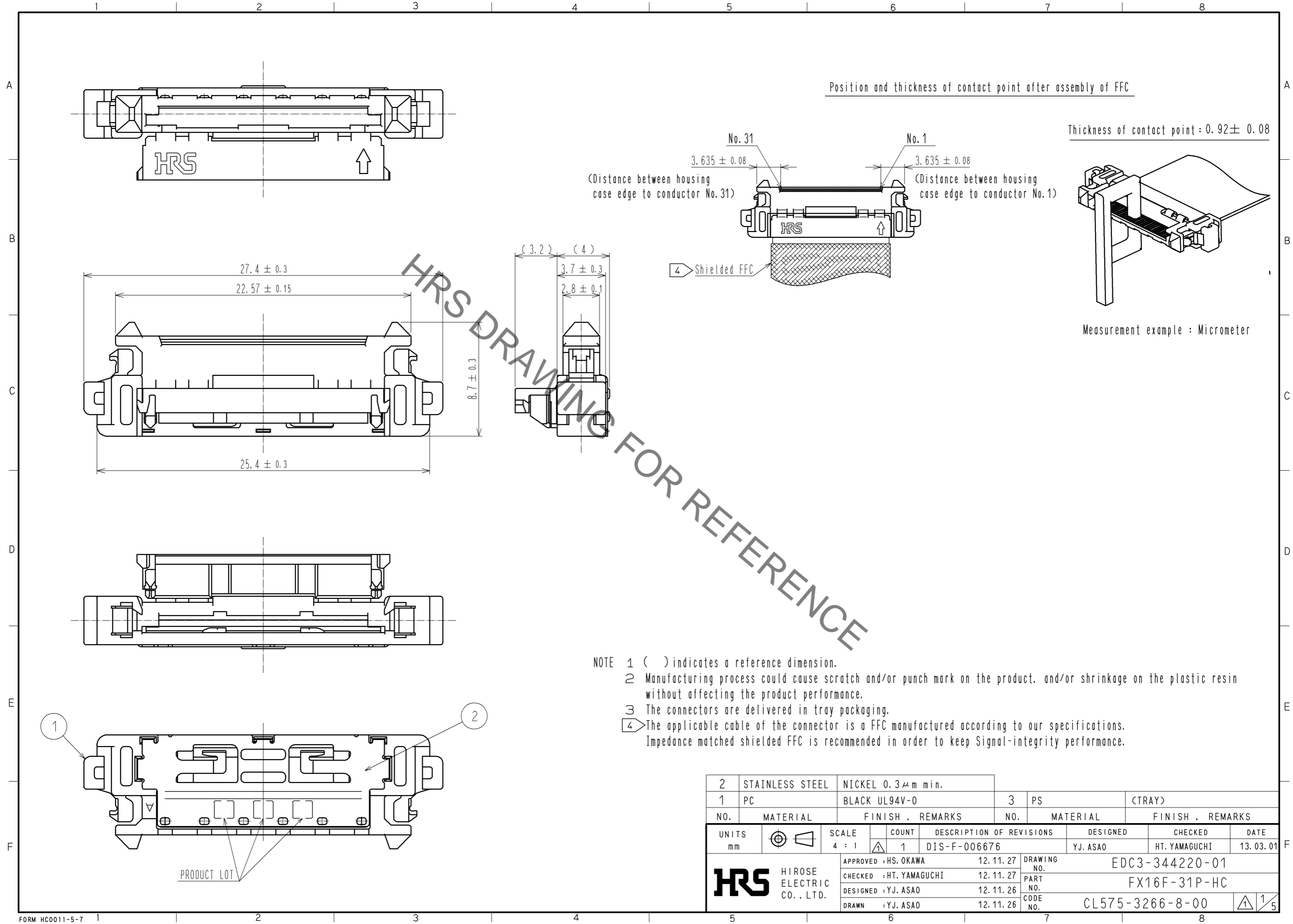

HRS DRAWING FOR REFERENCE

- NOTE
- 1 ( ) indicates a reference dimension.
  - 2 Manufacturing process could cause scratch and/or punch mark on the product, and/or shrinkage on the plastic resin without affecting the product performance.
  - 3 The connectors are delivered in tray packaging.
  - 4 The applicable cable of the connector is a FFC manufactured according to our specifications. Impedance matched shielded FFC is recommended in order to keep Signal-integrity performance.

2	STAINLESS STEEL	NICKEL 0.3 μm min.	3	PS	(TRAY)
1	PC	BLACK UL94V-0			
NO.	MATERIAL	FINISH . REMARKS	NO.	MATERIAL	FINISH . REMARKS
UNITS		SCALE	COUNT	DESCRIPTION OF REVISIONS	
mm		4 : 1	1	DIS-F-006676	
DESIGNED			CHECKED		
Y.J. ASAO			HT. YAMAGUCHI		
DATE			DATE		
13. 03. 01			12. 11. 27		
APPROVED : HS. OKAWA			DRAWING NO. EDC3-344220-01		
CHECKED : HT. YAMAGUCHI			PART NO. FX16F-31P-HC		
DESIGNED : Y.J. ASAO			CODE NO. CL575-3266-8-00		
DRAWN : Y.J. ASAO			1/5		

Jul.1.2019 Copyright 2019 HIROSE ELECTRIC CO., LTD. All Rights Reserved.  
In case of consideration for using Automotive equipment / device which demand high reliability, kindly contact our sales window correspondents.

# DRAWING FOR PACKING(1:2)

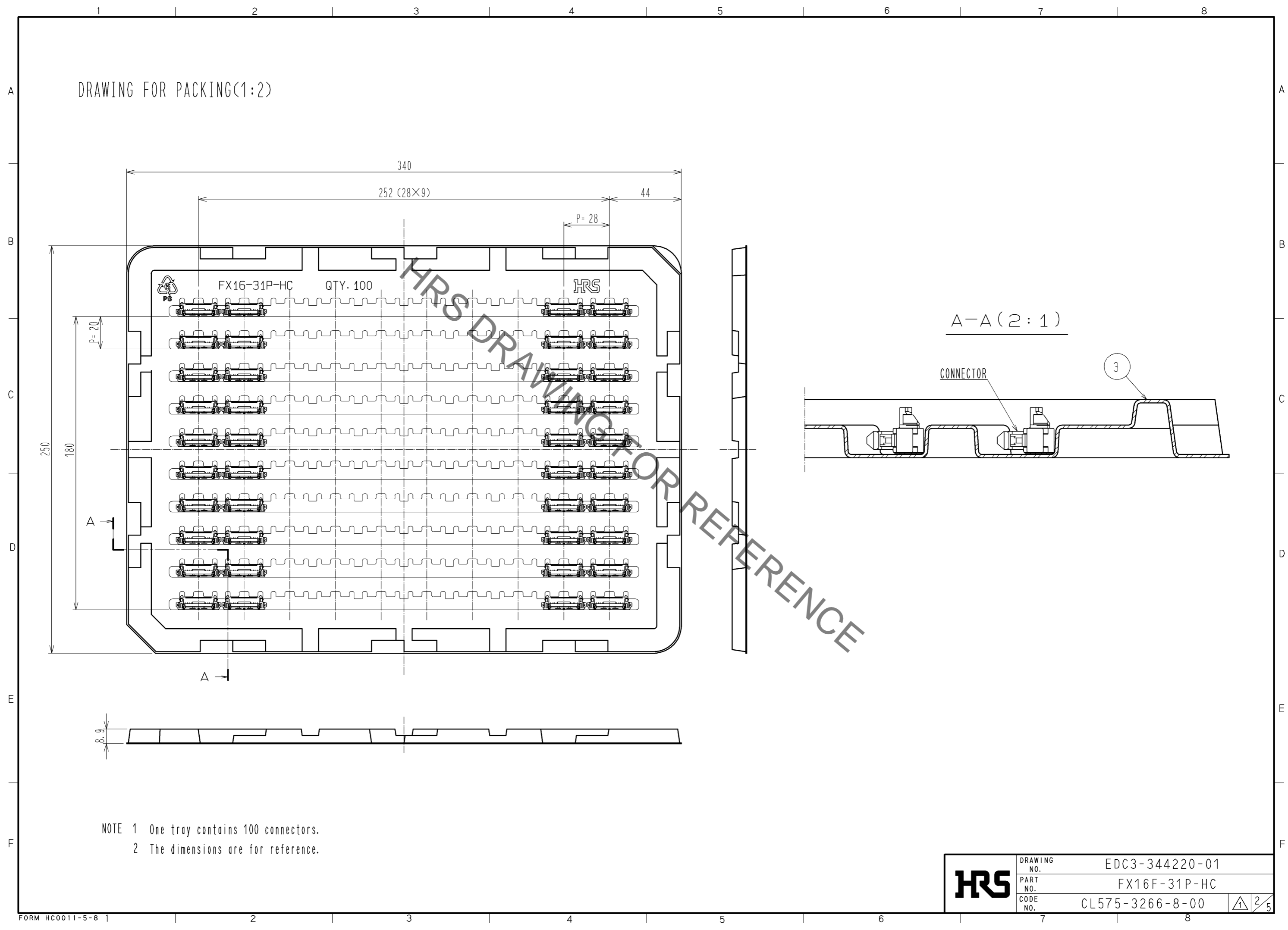

- NOTE 1 One tray contains 100 connectors.
- NOTE 2 The dimensions are for reference.

<b>HRS</b>	DRAWING NO.	EDC3-344220-01
	PART NO.	FX16F-31P-HC
	CODE NO.	CL575-3266-8-00
		2/5

**HANDLING INSTRUCTIONS**

**[ 1 ] Insertion to on-board connector**

The connector mating is keyed. Align the marks as shown in the figure for mating. Insert the connector completely until they are locked at both ends.

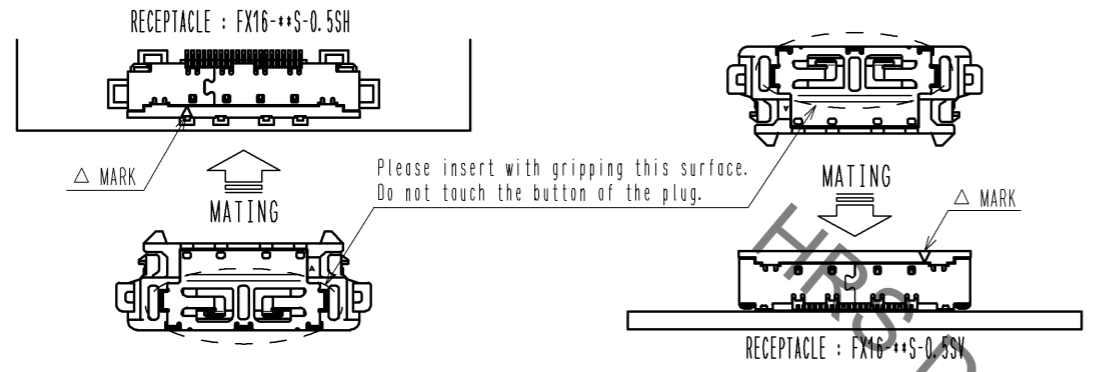

The connectors have a reverse-insertion prevention structure. However, the connectors may be damaged when inserted reversely with the force of 25N or more. Avoid a forceful insertion and make sure to confirm that the connectors are aligned with the marks before the mating operation.

**[ 2 ] After mating**

Carefully wire FFC, so that excessive force will not be applied to the mated connector. Pulling the FFC with the force of 10N or more may damage the connector. It may also cause FFC breakage. Take a caution to avoid pulling the FFC.

Repetitive FFC strokes could also cause FFC breakage as well. Do not use the connector under the environment of repetitive FFC strokes.

Take enough bend radius and/or distance from the connector for FFC not to apply stress to the connector base when the application requires FFC bend back.

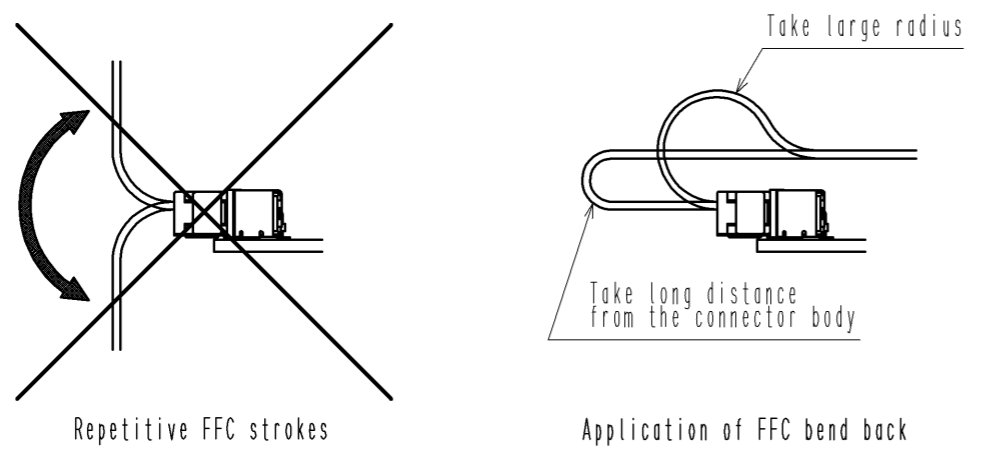

**[ 3 ] Withdrawal from on-board connector**

The connectors are locked while they are mated. In order to unmate the connectors, pull out straight with the button pushed to release the lock. At this time, do not pull the FFC. Also avoid the withdrawal in angle, which may damage the connectors.

**<Correct withdrawal>**

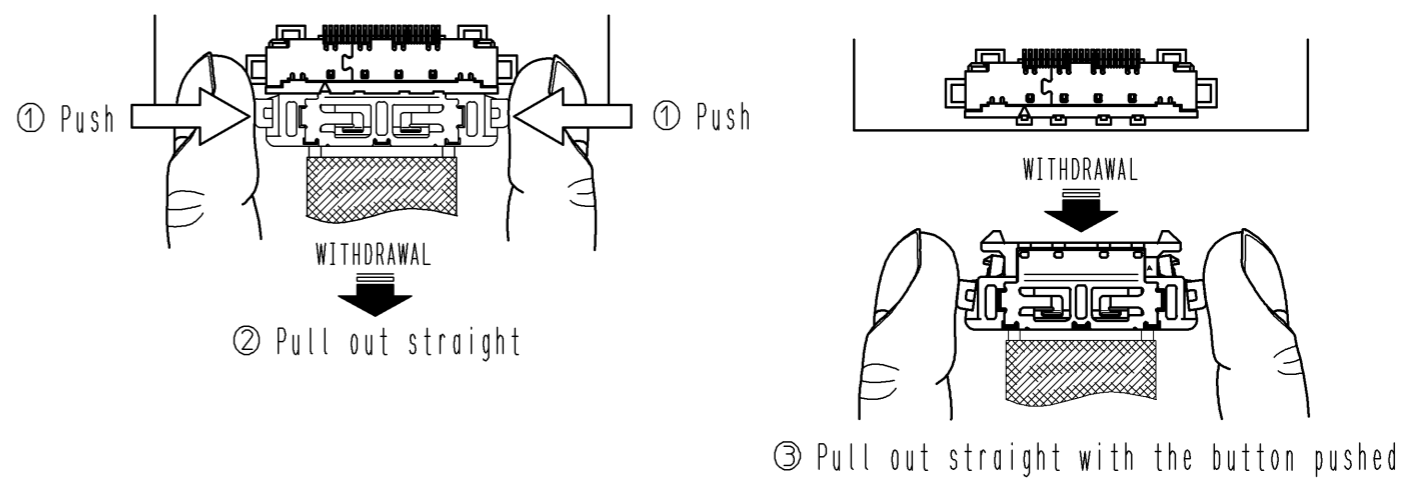

**<Incorrect withdrawal>**

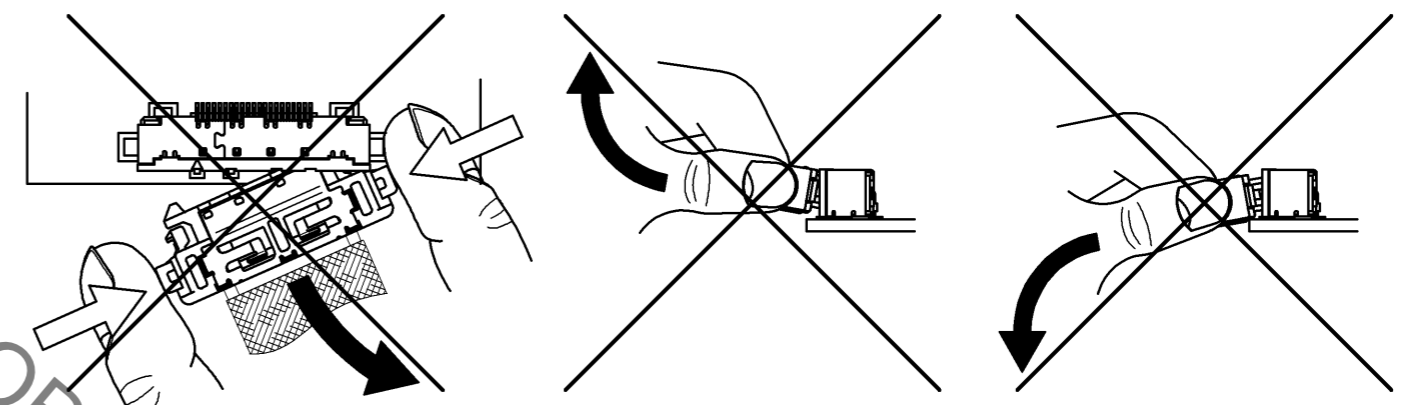

**[ 4 ] For the case that connector is withdrawn in condition that lock on one side is locked**

In case connector is withdrawn in condition that lock on one side is locked, it could damage the locking part. In such case, do not withdraw forcefully, but mate the plug again and pull out the plug in condition that the two locks are locked and withdraw with <Correct withdrawal> method.

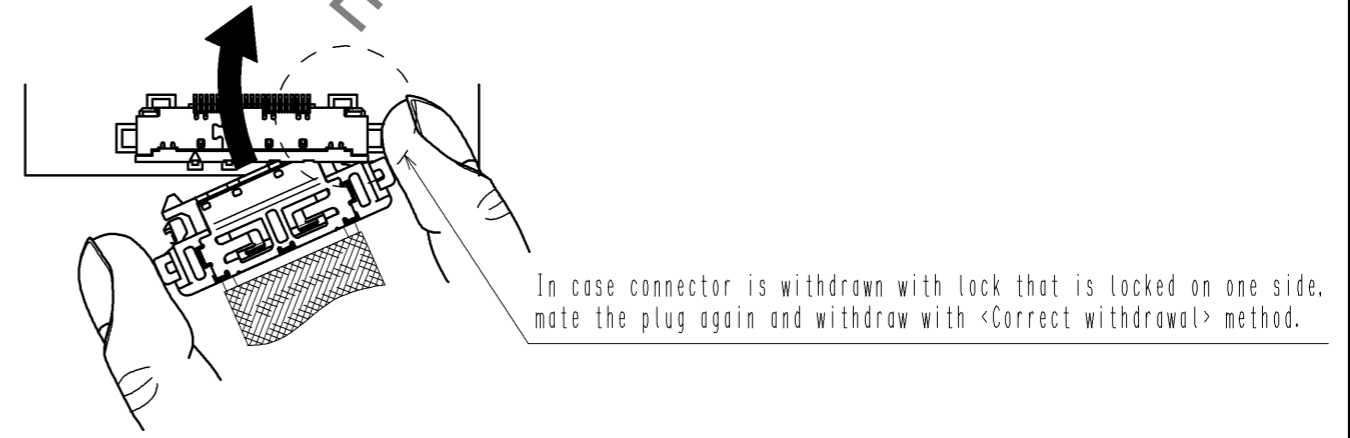

\*Note : The connectors shown in this 'HANDLING INSTRUCTIONS' are drawn for the instruction purpose. Therefore, the appearance differs from the actual connectors. Please confirm the connector configuration on the connector drawing (SHEET 1).

<b>HRS</b>	DRAWING NO.	EDC3-344220-01
	PART NO.	FX16F-31P-HC
	CODE NO.	CL575-3266-8-00
		3/5

Jul.1.2019 Copyright 2019 HIROSE ELECTRIC CO., LTD. All Rights Reserved. In case of consideration for using Automotive equipment / device which demand high reliability, kindly contact our sales window correspondents.

Jul.1.2019 Copyright 2019 HIROSE ELECTRIC CO., LTD. All Rights Reserved.  
 In case of consideration for using Automotive equipment / device which demand high reliability, kindly contact our sales window correspondents.

Please read the notification below before handling the connector.

**PRECAUTION FOR HARNESS**

\*Please make sure not to touch conductor of FFC.

**[ 1 ] How to insert FFC**

FFC needs to be inserted straight in alignment with mold lib as shown on illustration below.  
 In case FFC is inserted wrong direction, FFC can not be inserted.  
 In the worst case, FFC will be deformed, plastic housing, spring terminal will be broken, so please be aware of these points.

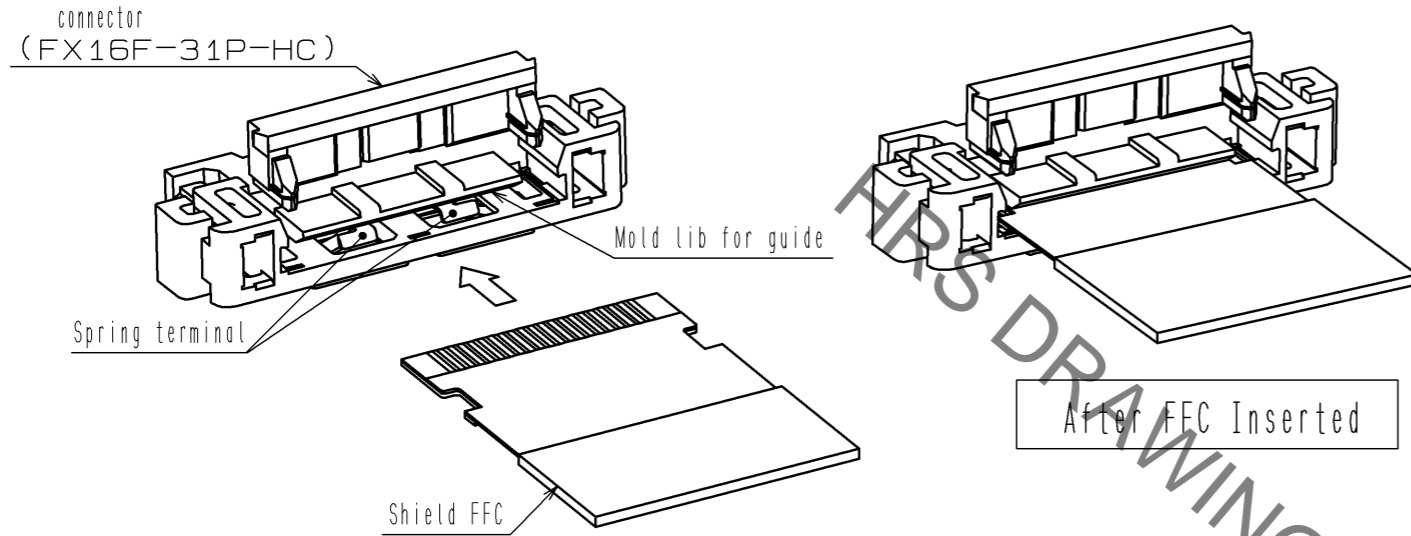

**[ 3 ] How to fix FFC**

Hold the connector with both hands and put the thumb near the fook of both sides of the hinged actuator as shown in the figure below.  
 Then push down both sides of the hinged actuator at the same time.  
 After closing hinged actuator, hold both sides of the plastic housing and pull the FFC to FFC layout direction by 3 to 5N, then verify that FFC does not come off from the plastic housing and fit to both side hooks completely.

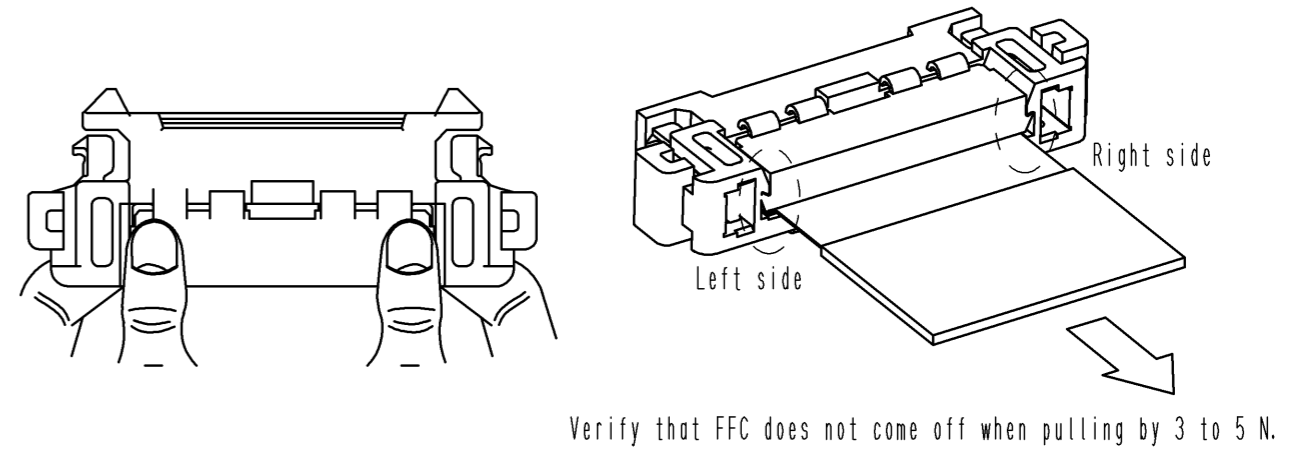

**[ 2 ] How to check FFC inserted position**

Verify that the position of FFC end face from directly above to check whether FFC inserted to correct position.  
 When inserted correctly, the end of FFC is visible through the square holes in the plastic housing.  
 \*Please check that the end of FFC hits the wall of the plastic housing.

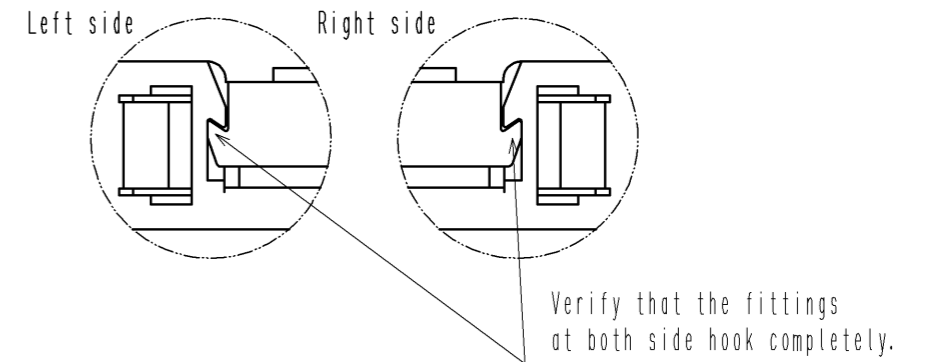
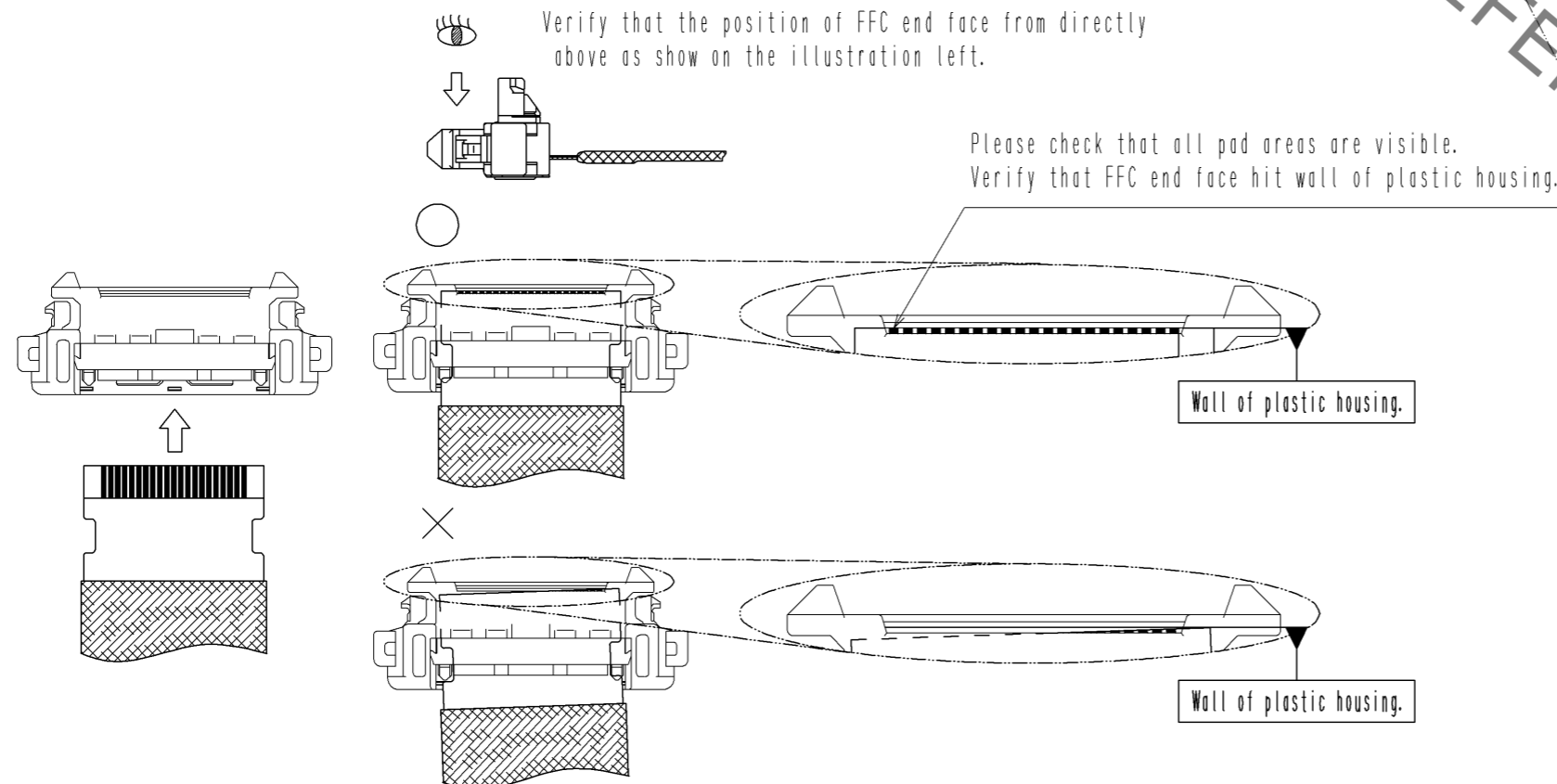

**[ 4 ] Other precautions**

① Do not apply forces to the hinged actuator to the direction as shown below, and also avoid closing it to the locked position until the correct process in cable assembly. Do not use the connector when this happens.

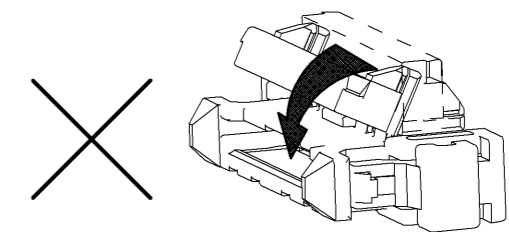

② Once removing the FFC from the plug housing after cable assembly, do not reuse.  
 ③ For the packing of the plug after cable assembly, do not damage and/or deform the product.

\*Note : The connectors shown in this 'PRECAUTION FOR HARNESS' are drawn for the instruction purpose. Therefore, the appearance differs from the actual connectors. Please confirm the connector configuration on the connector drawing (SHEET 1).

<b>HRS</b>	DRAWING NO.	EDC3-344220-01	4/5
	PART NO.	FX16F-31P-HC	
	CODE NO.	CL575-3266-8-00	

Jul.1.2019 Copyright 2019 HIROSE ELECTRIC CO., LTD. All Rights Reserved.  
 In case of consideration for using Automotive equipment / device which demand high reliability, kindly contact our sales window correspondents.

Applicable FFC dimensions

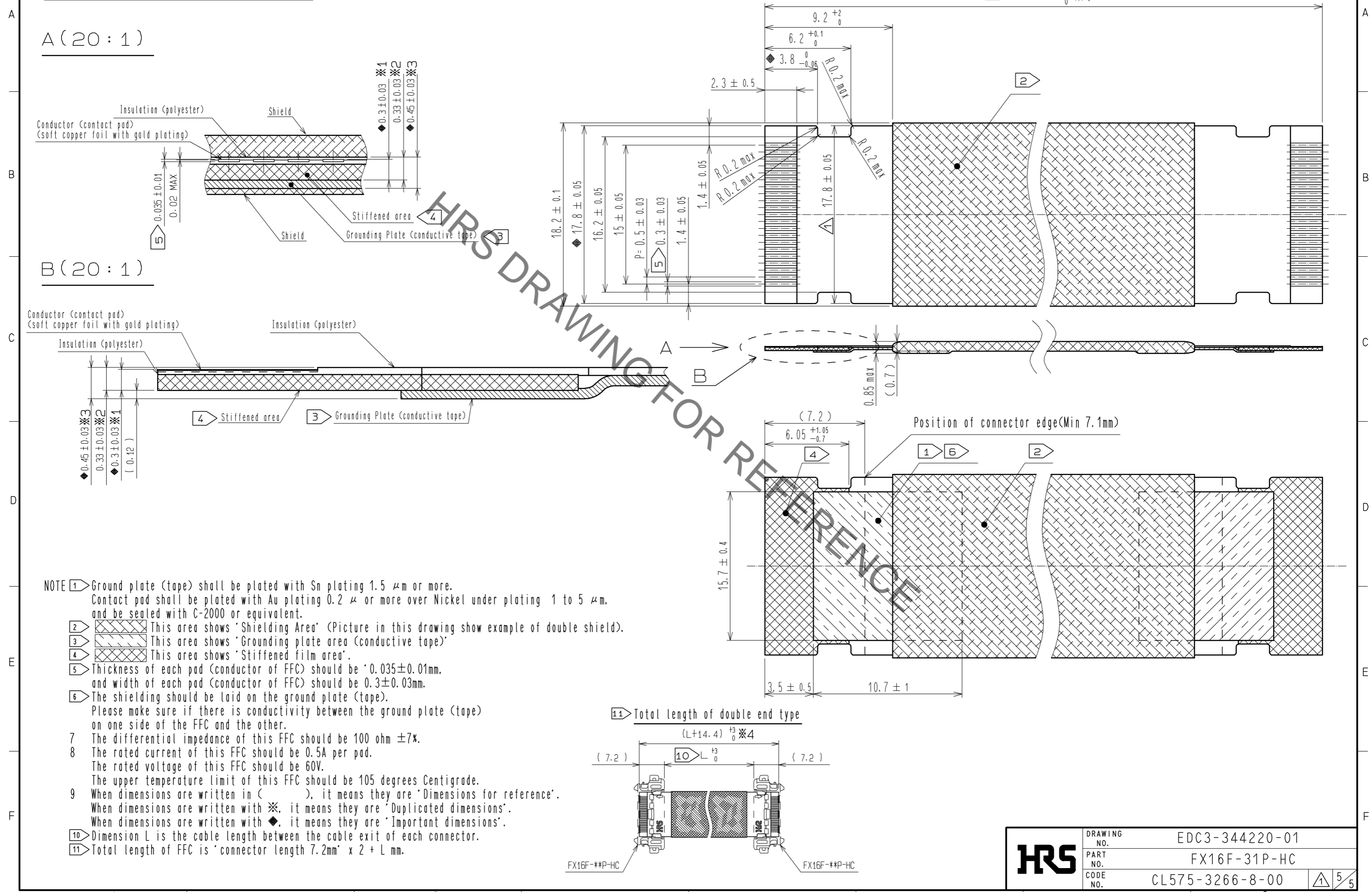

<b>HRS</b>	DRAWING NO.	EDC3-344220-01
	PART NO.	FX16F-31P-HC
	CODE NO.	CL575-3266-8-00
		5/5



Компания «ЭлектроПласт» предлагает заключение долгосрочных отношений при поставках импортных электронных компонентов на взаимовыгодных условиях!

Наши преимущества:

- Оперативные поставки широкого спектра электронных компонентов отечественного и импортного производства напрямую от производителей и с крупнейших мировых складов;
- Поставка более 17-ти миллионов наименований электронных компонентов;
- Поставка сложных, дефицитных, либо снятых с производства позиций;
- Оперативные сроки поставки под заказ (от 5 рабочих дней);
- Экспресс доставка в любую точку России;
- Техническая поддержка проекта, помощь в подборе аналогов, поставка прототипов;
- Система менеджмента качества сертифицирована по Международному стандарту ISO 9001;
- Лицензия ФСБ на осуществление работ с использованием сведений, составляющих государственную тайну;
- Поставка специализированных компонентов (Xilinx, Altera, Analog Devices, Intersil, Interpoint, Microsemi, Aeroflex, Peregrine, Syfer, Eurofarad, Texas Instrument, Miteq, Cobham, E2V, MA-COM, Hittite, Mini-Circuits, General Dynamics и др.);

Помимо этого, одним из направлений компании «ЭлектроПласт» является направление «Источники питания». Мы предлагаем Вам помощь Конструкторского отдела:

- Подбор оптимального решения, техническое обоснование при выборе компонента;
- Подбор аналогов;
- Консультации по применению компонента;
- Поставка образцов и прототипов;
- Техническая поддержка проекта;
- Защита от снятия компонента с производства.



#### Как с нами связаться

**Телефон:** 8 (812) 309 58 32 (многоканальный)

**Факс:** 8 (812) 320-02-42

**Электронная почта:** [org@eplast1.ru](mailto:org@eplast1.ru)

**Адрес:** 198099, г. Санкт-Петербург, ул. Калинина, дом 2, корпус 4, литера А.