

## Micropower high precision series voltage reference



QFN8 1.5x1.5

### Features

- Fixed 1.25 V, 1.8 V, 2.048 V, 2.5 V, 3.0 V, 3.3 V, 4.096 V, 5.0 V output voltage
- Ultra low operating current: 3.9  $\mu$ A (typ.) at 25 °C
- High initial accuracy: +/-0.15 %
- Stable when used with capacitive loads
- Extended temperature range: -40 to +125 °C
- 30 ppm/°C maximum temperature coefficient
- Available in QFN8 1.5x1.5 package

### Applications

- Portable equipment
- Data acquisition systems
- Instrumentation
- Medical equipment
- Test equipment

### Description

The TS33 family of low power series voltage references is capable of providing stable and precise output voltages with an initial accuracy of 0.15% over an extended temperature range (-40 to +125 °C).

The ultra low operating current is a key advantage for power-restricted designs. In addition, the TS33 is very stable over the entire operating temperature range, making it suitable for high-precision applications.

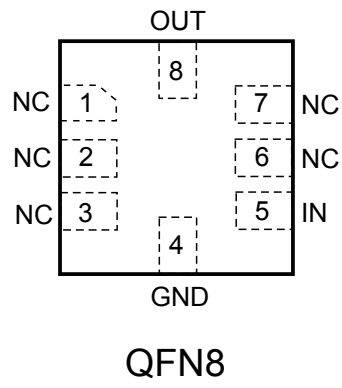
Available in QFN8 surface mount packages, the TS33 can be designed in applications where space saving is a critical issue.

Maturity status link

TS33

# 1 Pin configuration

Figure 2. Pin configuration (top view)



GAMG190120171500MT

## 2 Maximum ratings

**Table 1. Absolute maximum ratings**

Symbol	Parameter	Value	Unit
$V_{IN}$	Maximum input voltage	-0.3 to 7	V
$V_{OUT}$	Maximum voltage on the output pin	-0.3 to $V_{IN} + 0.3$	V
$I_{OUT}$	Output short-circuit current (sinking/sourcing)	Internally limited	mA
$P_d$	Power dissipation <sup>(1)</sup>	700	mW
$T_{stg}$	Storage temperature	-65 to +150	°C
ESD	Human body model (HBM)	4	kV
	Charged device model	1000	V
$T_{lead}$	Lead temperature (soldering) 10 s	260	°C
$T_j$	Max junction temperature	+150	°C

1.  $P_d$  has been calculated with  $T_{amb} = 25\text{ °C}$  and  $T_{jmax} = 150\text{ °C}$

**Note:** Absolute maximum ratings are those values beyond which damage to the device may occur. Functional operation under these conditions is not implied.

**Table 2. Thermal data**

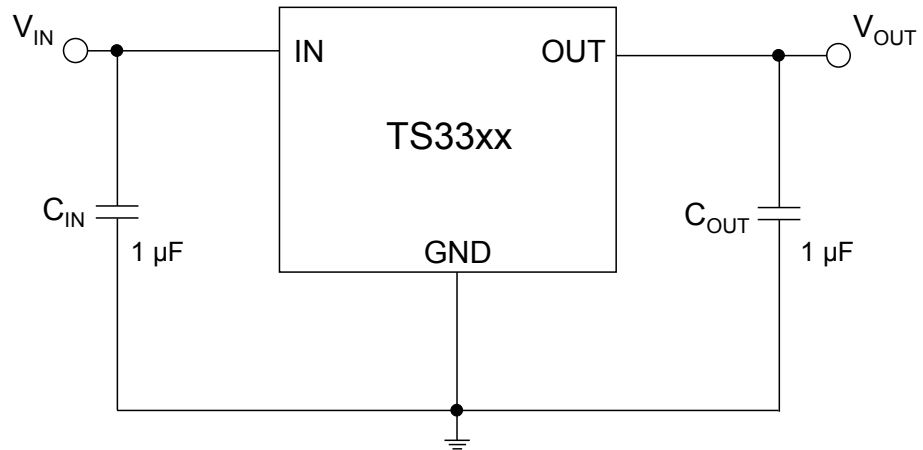
Symbol	Parameter	Value	Unit
$R_{thJA}$	Thermal resistance junction-ambient	159	°C/W
$R_{thJC}$	Thermal resistance junction-case	103	°C/W

**Table 3. Recommended operating conditions**

Symbol	Parameter	Value	Unit
$V_{IN}$	Operating input voltage range	1.8 to 5.5	V
$I_{OUT}$	Maximum operating current	±5	mA
$T_{oper}$	Operating free air temperature range	-40 to +125	°C

### 3 Typical application

Figure 3. Typical application circuit



## 4 Electrical characteristics

$V_{IN} = 5\text{ V}$ ,  $I_{LOAD} = 0\text{ mA}$ ,  $T_{amb} = 25\text{ °C}$  (unless otherwise specified).

**Table 4. Electrical characteristics for TS3312**

Symbol	Parameter	Test condition	Min.	Typ.	Max.	Unit
$V_{IN}$	Minimum input voltage	$I_{LOAD} = 0\text{ mA}$ $T_{amb} = 25\text{ °C}$	1.8			V
$V_{OUT}$	Output voltage	$V_{IN} = 5\text{ V}$		1.25		V
	Initial accuracy	$I_{LOAD} = 0\text{ mA}$ $T_{amb} = 25\text{ °C}$	-0.15		0.15	%
$\Delta V_{OUT}/\Delta T$	Average temperature coefficient	$-40\text{ °C} < T_{amb} < +85\text{ °C}$		9	30	ppm/°C
		$-40\text{ °C} < T_{amb} < +125\text{ °C}$		8	30	
$\Delta V_{OUT}/\Delta V_{IN}$	Line regulation	$V_{IN} = 1.8\text{ V to } 5.5\text{ V}$	-50	6	+50	ppm/V
		$0\text{ °C} < T_{amb} < 70\text{ °C}$		6		
		$-40\text{ °C} < T_{amb} < +85\text{ °C}$		8		
		$-40\text{ °C} < T_{amb} < +125\text{ °C}$		30		
$\Delta V_{OUT}/\Delta I_{LOAD}$	Load regulation	$V_{IN} = 1.8\text{ V}$	-50	6	+50	ppm/mA
		$I_{LOAD} = \pm 5\text{ mA}$ $0\text{ °C} < T_{amb} < 70\text{ °C}$		10		
		$-40\text{ °C} < T_{amb} < +85\text{ °C}$		20		
		$-40\text{ °C} < T_{amb} < +125\text{ °C}$		20		
$I_{SC}$	Short-circuit current sourcing/ sinking			35		mA
$I_Q$	Quiescent current			3.9	7	$\mu\text{A}$
		$-40\text{ °C} < T_{amb} < +85\text{ °C}$		4.4	7.5	
		$-40\text{ °C} < T_{amb} < +125\text{ °C}$		4.8	10	
$C_{OUT}$	Capacitive load		0.1		10	$\mu\text{F}$
$T_{ON}$	Turn-on settling time	to 0.1 %, $C_{OUT} = 1\text{ }\mu\text{F}$		2		ms
$e_n$	Noise floor	$f = 0.1\text{ Hz to } 10\text{ Hz}$		35		$\mu\text{V}_{P-P}$

**Table 5. Electrical characteristics for TS3330**

Symbol	Parameter	Test conditions	Min.	Typ.	Max.	Unit
$V_{OUT}$	Output voltage	$V_{IN} = 5\text{ V}$		3.0		V
	Initial accuracy	$I_{LOAD} = 0\text{ mA}$ $T_{amb} = 25\text{ °C}$	-0.15		0.15	%
$\Delta V_{OUT}/\Delta T$	Average temperature coefficient	$-40\text{ °C} < T_{amb} < +85\text{ °C}$		9	30	ppm/°C
		$-40\text{ °C} < T_{amb} < +125\text{ °C}$		8	30	
$\Delta V_{OUT}/\Delta V_{IN}$	Line regulation	$V_{IN} = 3.2\text{ V to } 5.5\text{ V}$	-50	6	+50	ppm/V
		$0\text{ °C} < T_{amb} < 70\text{ °C}$		6		
		$-40\text{ °C} < T_{amb} < +85\text{ °C}$		8		
		$-40\text{ °C} < T_{amb} < +125\text{ °C}$		30		
$\Delta V_{OUT}/\Delta I_{LOAD}$	Load regulation	$V_{IN} = 3.2\text{ V}$	-50	6	+50	ppm/mA
		$I_{LOAD} = \pm 5\text{ mA}$ $0\text{ °C} < T_{amb} < 70\text{ °C}$		10		
		$-40\text{ °C} < T_{amb} < +85\text{ °C}$		20		
		$-40\text{ °C} < T_{amb} < +125\text{ °C}$		20		
$V_{DROP}$	Minimum dropout voltage	$V_{IN} = 3.2\text{ V}$ $I_{LOAD} = \pm 5\text{ mA}$ $0\text{ °C} < T_{amb} < 70\text{ °C}$		50	100	mV
		$-40\text{ °C} < T_{amb} < +85\text{ °C}$		70		
		$-40\text{ °C} < T_{amb} < +125\text{ °C}$		75		
		$-40\text{ °C} < T_{amb} < +125\text{ °C}$		80		
		$I_{LOAD} = \pm 2\text{ mA}$ $-40\text{ °C} < T_{amb} < +85\text{ °C}$			70	
$I_{SC}$	Short-circuit current sourcing/sinking			35		mA
$I_Q$	Quiescent current			3.9	7	$\mu\text{A}$
		$-40\text{ °C} < T_{amb} < +85\text{ °C}$		4.4	7.5	
		$-40\text{ °C} < T_{amb} < +125\text{ °C}$		4.8	10	
$C_{OUT}$	Capacitive load		0.1		10	$\mu\text{F}$
$T_{ON}$	Turn-on settling time	to 0.1 %, $C_{OUT} = 1\text{ }\mu\text{F}$		2		ms
$e_n$	Noise floor	$f = 0.1\text{ Hz to } 10\text{ Hz}$		67		$\mu\text{V}_{P-P}$

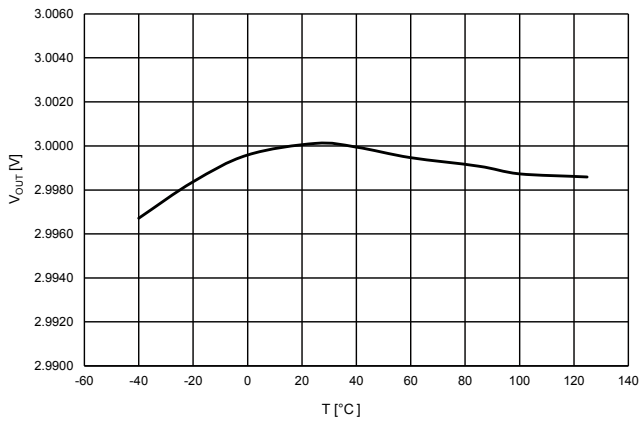
**Table 6. Electrical characteristics for TS3333**

Symbol	Parameter	Test conditions	Min.	Typ.	Max.	Unit
$V_{OUT}$	Output voltage	$V_{IN} = 5\text{ V}$		3.3		V
	Initial accuracy	$I_{LOAD} = 0\text{ mA}$ $T_{amb} = 25\text{ °C}$	-0.15		0.15	%
$\Delta V_{OUT}/\Delta T$	Average temperature coefficient	$-40\text{ °C} < T_{amb} < +85\text{ °C}$		9	30	ppm/°C
		$-40\text{ °C} < T_{amb} < +125\text{ °C}$		8	30	
$\Delta V_{OUT}/\Delta V_{IN}$	Line regulation	$V_{IN} = 3.5\text{ V to } 5.5\text{ V}$	-50	6	+50	ppm/V
		$0\text{ °C} < T_{amb} < 70\text{ °C}$		6		
		$-40\text{ °C} < T_{amb} < +85\text{ °C}$		8		
		$-40\text{ °C} < T_{amb} < +125\text{ °C}$		30		
$\Delta V_{OUT}/\Delta I_{LOAD}$	Load regulation	$V_{IN} = 3.5\text{ V}$	-50	6	+50	ppm/mA
		$I_{LOAD} = \pm 5\text{ mA}$ $0\text{ °C} < T_{amb} < 70\text{ °C}$		10		
		$-40\text{ °C} < T_{amb} < +85\text{ °C}$		20		
		$-40\text{ °C} < T_{amb} < +125\text{ °C}$		20		
$V_{DROP}$	Minimum dropout voltage	$V_{IN} = 3.5\text{ V}$ $I_{LOAD} = \pm 5\text{ mA}$ $0\text{ °C} < T_{amb} < 70\text{ °C}$		50	100	mV
		$-40\text{ °C} < T_{amb} < +85\text{ °C}$		70		
		$-40\text{ °C} < T_{amb} < +125\text{ °C}$		75		
		$-40\text{ °C} < T_{amb} < +125\text{ °C}$		80		
		$I_{LOAD} = \pm 2\text{ mA}$ $-40\text{ °C} < T_{amb} < +85\text{ °C}$			70	
$I_{SC}$	Short-circuit current sourcing/sinking			35		mA
$I_Q$	Quiescent current			3.9	7	$\mu\text{A}$
		$-40\text{ °C} < T_{amb} < +85\text{ °C}$		4.4	7.5	
		$-40\text{ °C} < T_{amb} < +125\text{ °C}$		4.8	10	
$C_{OUT}$	Capacitive load		0.1		10	$\mu\text{F}$
$T_{ON}$	Turn-on settling time	to 0.1 %, $C_{OUT} = 1\text{ }\mu\text{F}$		2		ms
$e_n$	Noise floor	$f = 0.1\text{ Hz to } 10\text{ Hz}$		73		$\mu\text{V}_{P-P}$

## 5 Typical performance characteristics

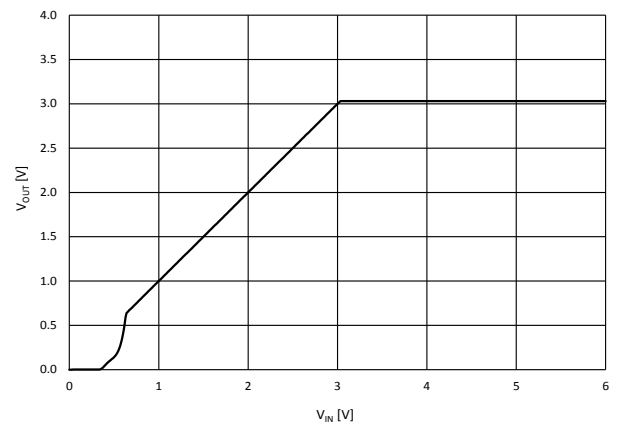
The following plots are referred to the typical application circuit and, unless otherwise noted, at  $T_A = 25\text{ }^\circ\text{C}$ ,  $V_{OUT} = 3.0\text{ V}$ .

**Figure 4. Output voltage vs. temperature**



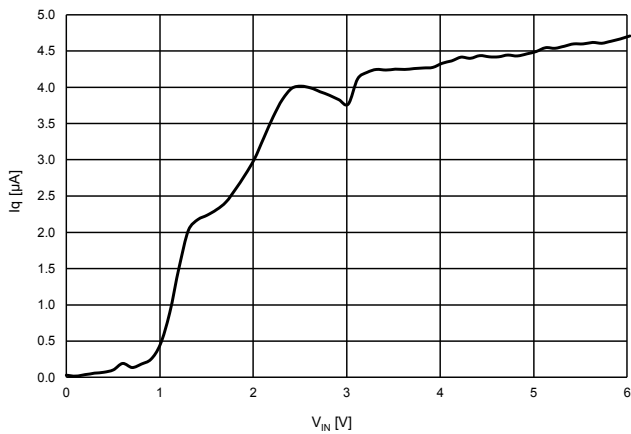
GAMG251120160930MT

**Figure 5. Output voltage vs. input voltage**



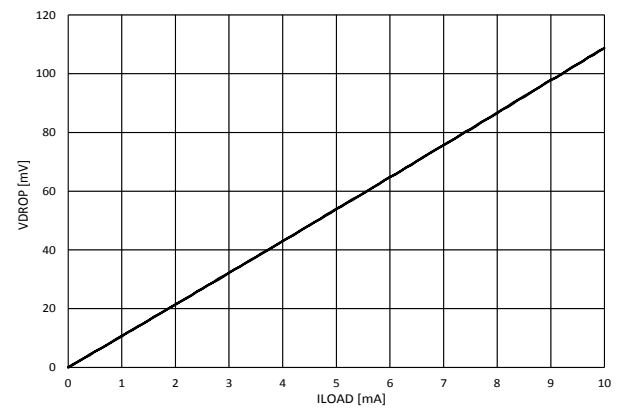
GAMG251120160931MT

**Figure 6. Quiescent current vs. input voltage**



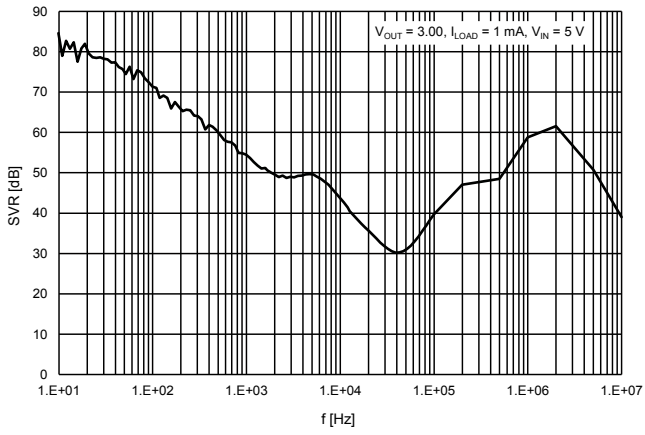
GAMG251120160932MT

**Figure 7. Dropout voltage vs. load current**

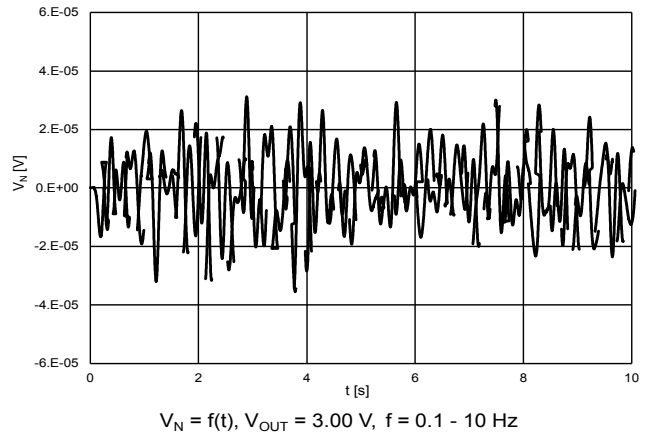


GAMG251120160933MT

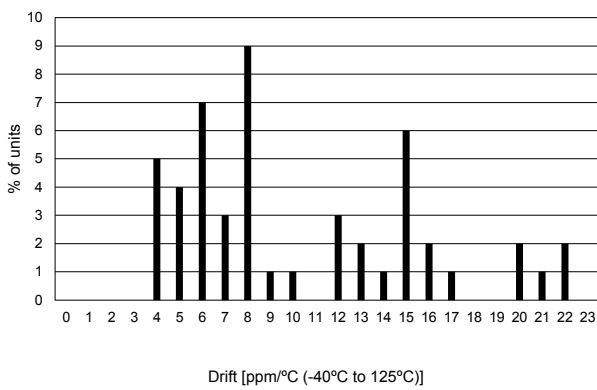


**Figure 8. SVR vs. frequency**


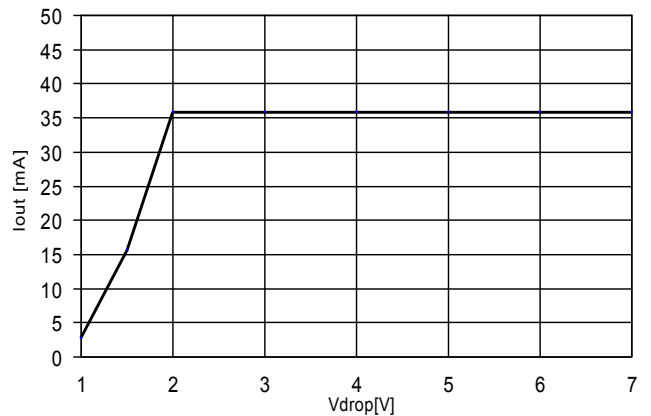
GAMG251120160934MT

**Figure 9. Low frequency noise**


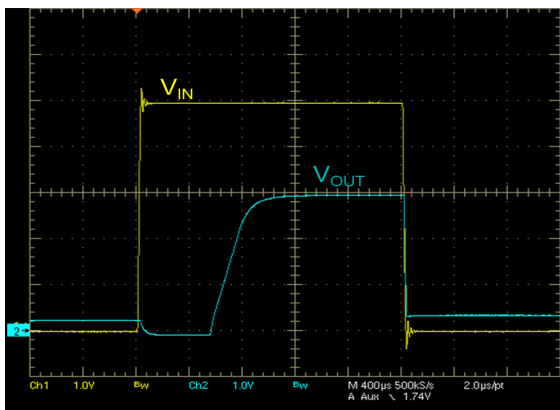
GAMG251120160935MT

**Figure 10. Temperature drift**


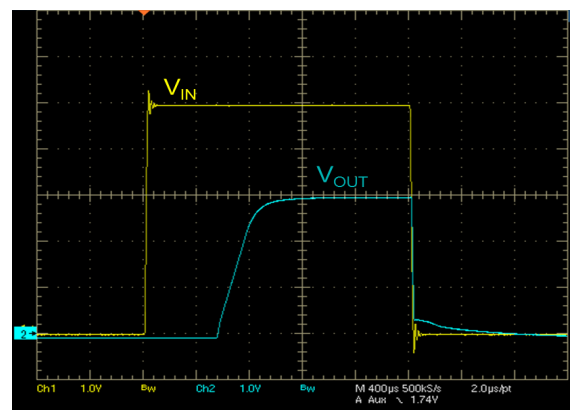
GAMG251120160936MT

**Figure 11. Short-circuit current vs. dropout voltage**

 $T = 25\text{ }^{\circ}\text{C}$ ,  $C_{in} = 1\text{ }\mu\text{F}$ ,  $C_{out} = 1\text{ }\mu\text{F}$ 

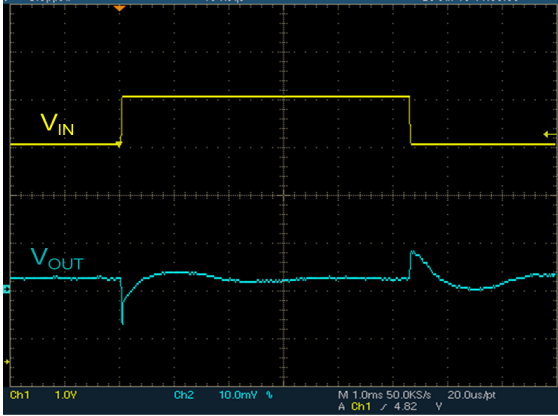
GAMG251120160937MT

**Figure 12. Startup transient (no load)**

 $V_{IN}$  from 0 to 5V,  $V_{OUT}=3\text{V}$ ,  $I_{OUT}=0\text{mA}$ ,  $C_{IN}= C_{OUT}= 1\mu\text{F}$ 

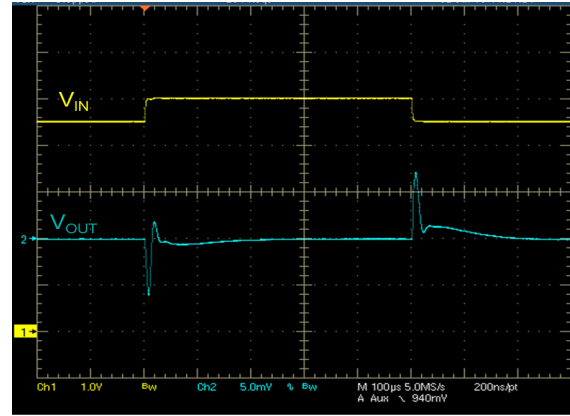
GAMG251120160938MT

**Figure 13. Startup transient ( $I_{OUT} = 5\text{ mA}$ )**

 $V_{IN}$  from 0 to 5V,  $V_{OUT}=3\text{V}$ ,  $I_{OUT}=5\text{mA}$ ,  $C_{IN}= C_{OUT}= 1\mu\text{F}$ 

GAMG251120160939MT

**Figure 14. Line transient (no load)**

 $V_{IN} = 5V, V_{OUT} = 3V, I_{OUT} = 0mA, C_{OUT} = 1\mu F, \Delta V_{IN} = 500mV$ 

GAMG251120160940MT

**Figure 15. Line transient ( $I_{OUT} = 1\text{ mA}$ )**

 $V_{IN} = 5V, V_{OUT} = 3V, I_{OUT} = 1mA, C_{OUT} = 1\mu F, \Delta V_{IN} = 500mV$ 

GAMG251120160941MT

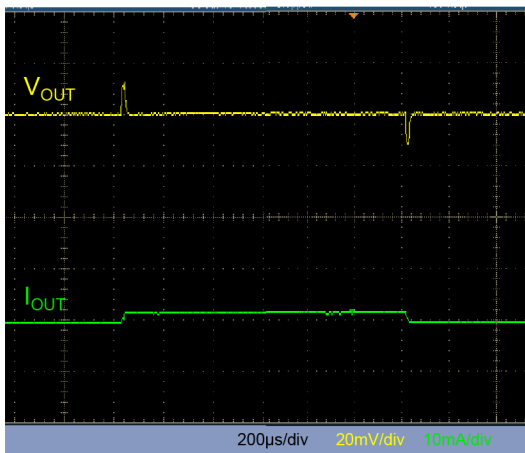
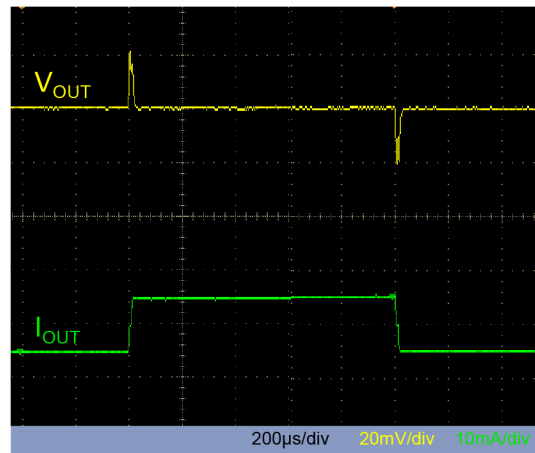
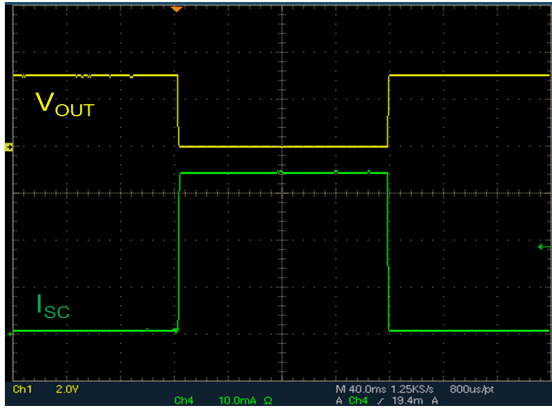
**Figure 16. Load transient ( $I_{OUT} = \pm 1\text{ mA}$ )**

 $V_{OUT} = 3V, I_{OUT} = \pm 1mA, C_{IN} = C_{OUT} = 1\mu F$ 
**Figure 17. Load transient ( $I_{OUT} = \pm 5\text{ mA}$ )**

 $V_{OUT} = 3V, I_{OUT} = \pm 5mA, C_{IN} = C_{OUT} = 1\mu F$

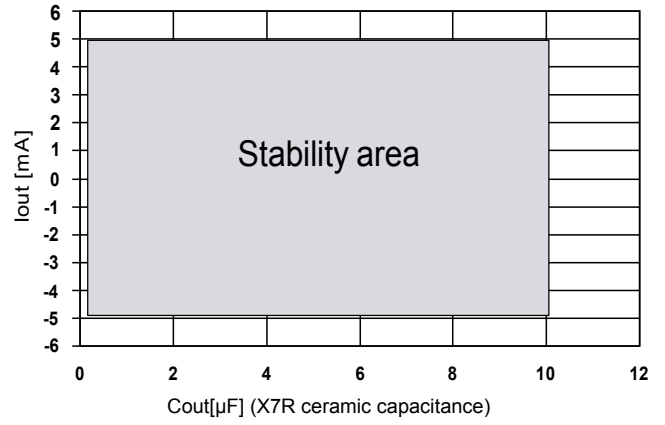
Figure 18. Short-circuit response



$V_{IN}=5V$ ,  $T=25^{\circ}C$ ,  $C_{IN}=1\mu F$ ,  $C_{OUT}=1\mu F$

GAMG251120160944MT

Figure 19. Stability plan



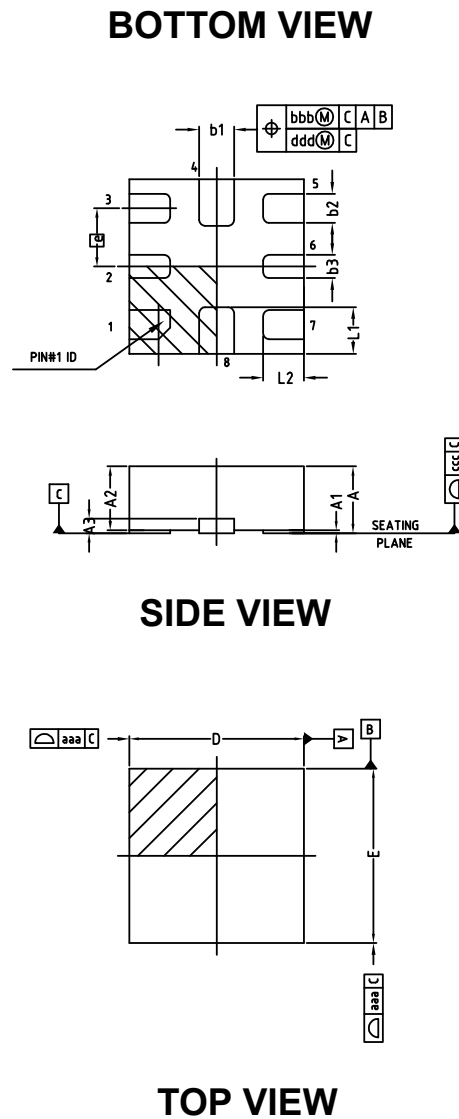
GAMG251120160945MT

## 6 Package information

In order to meet environmental requirements, ST offers these devices in different grades of ECOPACK® packages, depending on their level of environmental compliance. ECOPACK® specifications, grade definitions and product status are available at: [www.st.com](http://www.st.com). ECOPACK® is an ST trademark.

### 6.1 QFN8 package information

Figure 20. QFN8 package outline



DM00182817\_A

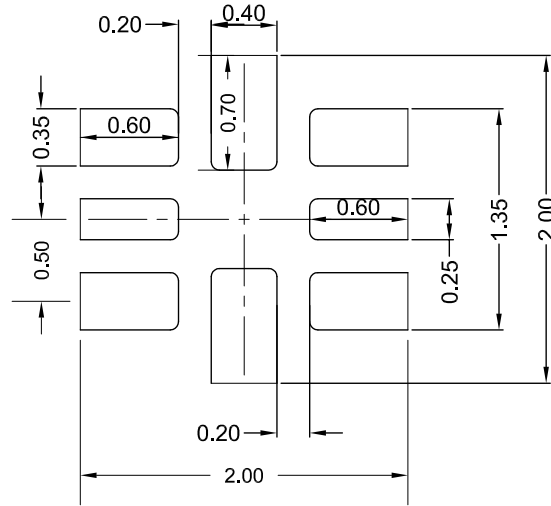
**Table 7. QFN8 mechanical data**

Dim.	mm			Note
	Min.	Typ.	Max.	
A	0.40	-	0.55	4
A1	0.00	-	0.05	12
A2	0.33	0.43	0.53	4
A3		-		4
b1	0.25	0.3	0.35	4.9
b2	0.20	0.25	0.30	
b3	0.15	0.20	0.25	
D	1.40	1.50	1.60	4
e		0.50		4
E	1.40	1.50	1.60	4
L1	0.30	0.40	0.50	4
L2	0.25	0.35	0.45	4
N		8		15

**Table 8. QFN8 tolerance of form and position**

Symbol	Tolerance of form and position
aaa	0.15
bbb	0.10
ccc	0.08
ddd	0.05
eee	0.10

Figure 21. QFN8 recommended footprint



DM00182817\_A

## 7 Ordering information

**Table 9. Order codes**

Part number	Output voltage (V)	Precision	Package	Temperature range
TS3312AQPR	1.25	±0.15 %	QFN8	-40 to +125 °C
TS3325AQPR <sup>(1)</sup>	2.5			
TS3330AQPR	3.0			
TS3333AQPR	3.3			

1. *In development.*

## Revision history

**Table 10. Document revision history**

Date	Revision	Changes
05-Sep-2017	1	Initial release.
26-Sep-2018	2	Added new order codes TS3325AQPR and TS3333AQPR in <a href="#">Table 9. Order codes.</a>



## Contents

<b>1</b>	<b>Pin configuration</b> .....	<b>2</b>
<b>2</b>	<b>Maximum ratings</b> .....	<b>3</b>
<b>3</b>	<b>Typical application</b> .....	<b>4</b>
<b>4</b>	<b>Electrical characteristics</b> .....	<b>5</b>
<b>5</b>	<b>Typical performance characteristics</b> .....	<b>8</b>
<b>6</b>	<b>Package information</b> .....	<b>12</b>
<b>6.1</b>	<b>QFN-8 package information</b> .....	<b>12</b>
<b>7</b>	<b>Ordering information</b> .....	<b>15</b>
	<b>Revision history</b> .....	<b>16</b>
	<b>Contents</b> .....	<b>17</b>
	<b>List of tables</b> .....	<b>18</b>
	<b>List of figures</b> .....	<b>19</b>

## List of tables

<b>Table 1.</b>	Absolute maximum ratings . . . . .	3
<b>Table 2.</b>	Thermal data . . . . .	3
<b>Table 3.</b>	Recommended operating conditions . . . . .	3
<b>Table 4.</b>	Electrical characteristics for TS3312 . . . . .	5
<b>Table 5.</b>	Electrical characteristics for TS3330 . . . . .	6
<b>Table 6.</b>	Electrical characteristics for TS3333 . . . . .	7
<b>Table 7.</b>	QFN8 mechanical data . . . . .	13
<b>Table 8.</b>	QFN8 tolerance of form and position . . . . .	13
<b>Table 9.</b>	Order codes . . . . .	15
<b>Table 10.</b>	Document revision history . . . . .	16

## List of figures

<b>Figure 2.</b>	Pin configuration (top view) . . . . .	2
<b>Figure 3.</b>	Typical application circuit . . . . .	4
<b>Figure 4.</b>	Output voltage vs. temperature . . . . .	8
<b>Figure 5.</b>	Output voltage vs. input voltage . . . . .	8
<b>Figure 6.</b>	Quiescent current vs. input voltage . . . . .	8
<b>Figure 7.</b>	Dropout voltage vs. load current . . . . .	8
<b>Figure 8.</b>	SVR vs. frequency . . . . .	9
<b>Figure 9.</b>	Low frequency noise . . . . .	9
<b>Figure 10.</b>	Temperature drift. . . . .	9
<b>Figure 11.</b>	Short-circuit current vs. dropout voltage . . . . .	9
<b>Figure 12.</b>	Startup transient (no load) . . . . .	9
<b>Figure 13.</b>	Startup transient ( $I_{OUT} = 5 \text{ mA}$ ) . . . . .	9
<b>Figure 14.</b>	Line transient (no load) . . . . .	10
<b>Figure 15.</b>	Line transient ( $I_{OUT} = 1 \text{ mA}$ ) . . . . .	10
<b>Figure 16.</b>	Load transient ( $I_{OUT} = +/-1 \text{ mA}$ ) . . . . .	10
<b>Figure 17.</b>	Load transient ( $I_{OUT} = +/-5 \text{ mA}$ ) . . . . .	10
<b>Figure 18.</b>	Short-circuit response . . . . .	11
<b>Figure 19.</b>	Stability plan . . . . .	11
<b>Figure 20.</b>	QFN8 package outline . . . . .	12
<b>Figure 21.</b>	QFN8 recommended footprint. . . . .	14

**IMPORTANT NOTICE – PLEASE READ CAREFULLY**

STMicroelectronics NV and its subsidiaries (“ST”) reserve the right to make changes, corrections, enhancements, modifications, and improvements to ST products and/or to this document at any time without notice. Purchasers should obtain the latest relevant information on ST products before placing orders. ST products are sold pursuant to ST’s terms and conditions of sale in place at the time of order acknowledgement.

Purchasers are solely responsible for the choice, selection, and use of ST products and ST assumes no liability for application assistance or the design of Purchasers’ products.

No license, express or implied, to any intellectual property right is granted by ST herein.

Resale of ST products with provisions different from the information set forth herein shall void any warranty granted by ST for such product.

ST and the ST logo are trademarks of ST. All other product or service names are the property of their respective owners.

Information in this document supersedes and replaces information previously supplied in any prior versions of this document.

© 2018 STMicroelectronics – All rights reserved



Компания «ЭлектроПласт» предлагает заключение долгосрочных отношений при поставках импортных электронных компонентов на взаимовыгодных условиях!

Наши преимущества:

- Оперативные поставки широкого спектра электронных компонентов отечественного и импортного производства напрямую от производителей и с крупнейших мировых складов;
- Поставка более 17-ти миллионов наименований электронных компонентов;
- Поставка сложных, дефицитных, либо снятых с производства позиций;
- Оперативные сроки поставки под заказ (от 5 рабочих дней);
- Экспресс доставка в любую точку России;
- Техническая поддержка проекта, помощь в подборе аналогов, поставка прототипов;
- Система менеджмента качества сертифицирована по Международному стандарту ISO 9001;
- Лицензия ФСБ на осуществление работ с использованием сведений, составляющих государственную тайну;
- Поставка специализированных компонентов (Xilinx, Altera, Analog Devices, Intersil, Interpoint, Microsemi, Aeroflex, Peregrine, Syfer, Eurofarad, Texas Instrument, Miteq, Cobham, E2V, MA-COM, Hittite, Mini-Circuits, General Dynamics и др.);

Помимо этого, одним из направлений компании «ЭлектроПласт» является направление «Источники питания». Мы предлагаем Вам помощь Конструкторского отдела:

- Подбор оптимального решения, техническое обоснование при выборе компонента;
- Подбор аналогов;
- Консультации по применению компонента;
- Поставка образцов и прототипов;
- Техническая поддержка проекта;
- Защита от снятия компонента с производства.



#### Как с нами связаться

**Телефон:** 8 (812) 309 58 32 (многоканальный)

**Факс:** 8 (812) 320-02-42

**Электронная почта:** [org@eplast1.ru](mailto:org@eplast1.ru)

**Адрес:** 198099, г. Санкт-Петербург, ул. Калинина, дом 2, корпус 4, литера А.