

Features

- Low Voltage Operation: 2.7 V
- High IP3: +56 dBm
- Low Insertion Loss: 0.30 dB at 1 GHz
- High Isolation: 25 dB at 1 GHz
- 0.5 micron GaAs PHEMT Process
- Lead-Free SC70 Package
- Halogen-Free “Green” Mold Compound
- 260°C Reflow Compatible
- RoHS* Compliant Version of MASWSS0117

Description

The MASWSS0204 is a GaAs pHEMT MMIC single pole double throw (SPDT) high power switch in a low cost SC70 six lead package. The MASWSS0204 is ideally suited for applications where high power, low control voltage, low insertion loss, high isolation, small size and low cost are required.

Typical applications are for CDMA handset systems that connect separate transceiver and/or GPS functions to a common antenna, as well as other related handset and general purpose applications. The MASWSS0204 can be used in all systems operating up to 3 GHz requiring high power at low control voltage.

The MASWSS0204 is fabricated using a 0.5 micron gate length GaAs pHEMT process. The process features full passivation for performance and reliability.

Functional Block Diagram

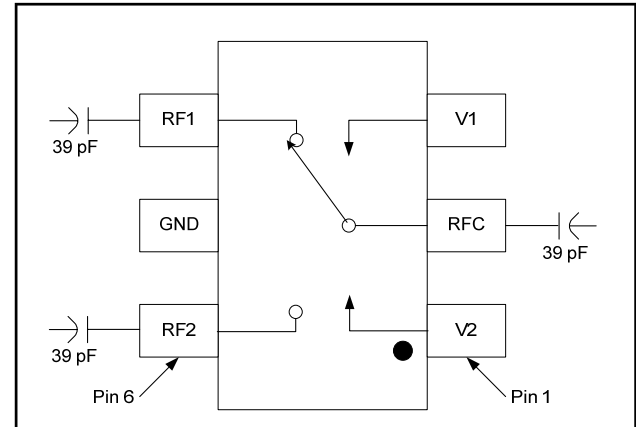

Pin Configuration

Pin No.	Pin Name	Description
1	V2	Vcontrol 2
2	RFC	RF Common
3	V1	Vcontrol 1
4	RF1	RF Port 1
5	GND	RF Ground
6	RF2	RF Port 2

MASWSS0204 orientation in tape

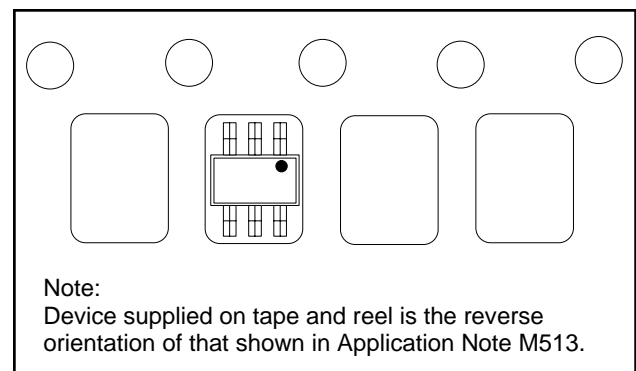

Ordering Information ^{1,2}

Part Number	Package
MASWSS0204	Bulk Packaging
MASWSS0204TR-3000	3000 piece reel
MASWSS0204SMB	Sample Test Board

1. Reference Application Note M513 for reel size information.
2. All sample boards include 5 loose parts.

* Restrictions on Hazardous Substances, European Union Directive 2002/95/EC.

GaAs SPDT 2.7 V High Power Switch DC - 3.0 GHz

Rev. V3

Electrical Specifications: $T_A = 25^\circ\text{C}$, $V_C = 0\text{ V}/2.7\text{ V}$, $Z_0 = 50\ \Omega$ ³

Parameter	Test Conditions	Units	Min.	Typ.	Max.
Insertion Loss ⁴	DC - 1 GHz	dB	—	0.30	0.65
	1 - 2 GHz		—	0.35	—
	2 - 3 GHz		—	0.35	—
Isolation	DC - 1 GHz	dB	23	25	—
	1 - 2 GHz		—	19	—
	2 - 3 GHz		—	15	—
Return Loss	DC - 3 GHz	dB	—	20	—
IP3	825 MHz Two Tone, +24 dBm Total Pin, 5 MHz Spacing	dBm	—	56	—
Cross Modulation	For Cell Band: Two-tone signal input: $T_{x1} = +22\text{ dBm @ } 820\text{ MHz}$, $T_{x2} = +22\text{ dBm @ } 821\text{ MHz}$, $R_x\text{ interfere} = -23\text{ dBm @ } 869\text{ MHz}$.	dBm	—	-99	—
	For PCS Band: Two-tone signal input: $T_{x1} = +18\text{ dBm @ } 1880\text{ MHz}$, $T_{x2} = +18\text{ dBm @ } 1881\text{ MHz}$, $R_x\text{ interfere} = -23\text{ dBm @ } 1960\text{ MHz}$.	dBm	—	-94	—
P0.1dB	1 GHz	dBm	—	38	—
Trise, Tfall	10% to 90% RF, 90% to 10% RF	ns	—	70	—
Ton, Toff	50% control to 90% RF, 50% control to 10% RF	ns	—	100	—
Transients	In Band	mV	—	25	—
Control Current	$V_C = 2.7\text{ V}$	μA	—	5	20

3. For positive voltage control, external DC blocking capacitors are required on all RF ports.

4. Insertion loss can be optimized by varying the DC blocking capacitor value, e.g. 1000 pF for 100 MHz - 1 GHz, 39 pF for 0.5 - 3 GHz.

Absolute Maximum Ratings ^{5,6}

Parameter	Absolute Maximum
Input Power (0.5 - 3 GHz, 3 V Control)	+38 dBm
Operating Voltage	+8.5 volts
Operating Temperature	-40°C to +85°C
Storage Temperature	-65°C to +150°C

5. Exceeding any one or combination of these limits may cause permanent damage to this device.

6. M/A-COM Technology does not recommend sustained operation near these survivability limits.

Truth Table ^{7,8,9}

V1	V2	ANT- RF1	ANT - RF2
1	0	On	Off
0	1	Off	On

7. For positive voltage control, external DC blocking capacitors are required on all RF ports.

8. Differential voltage, $V(\text{state } 1) - V(\text{state } 0)$, must be +2.7 V minimum, but must not exceed 8.5 V.

9. 0 = -5 V to +2.3 V, 1 = -2.3 V to +5 V.

Typical Performance Curves, 39 pF

Insertion Loss

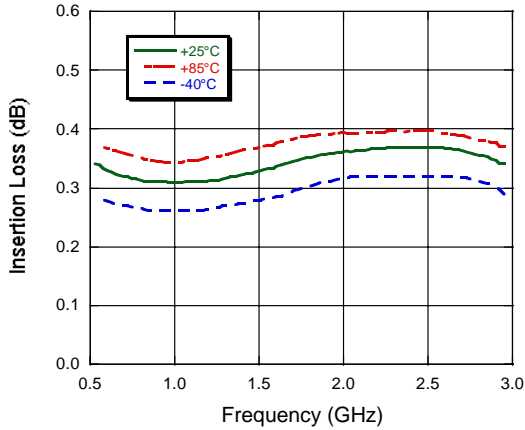

Isolation

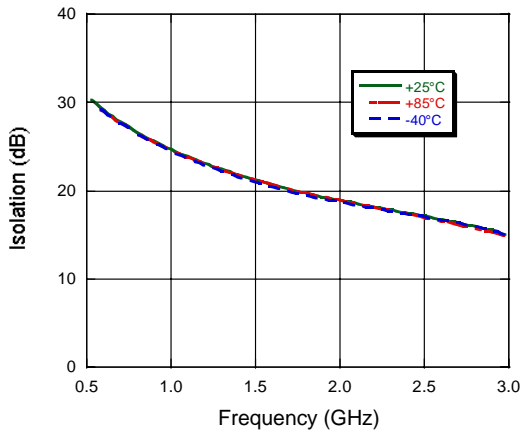

Return Loss

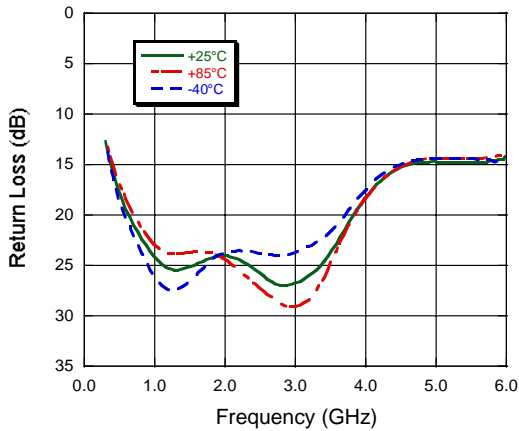

Qualification

Qualified to M/A-COM specification REL-201, Process Flow -2.

Handling Procedures

Please observe the following precautions to avoid damage:

Static Sensitivity

Gallium Arsenide Integrated Circuits are sensitive to electrostatic discharge (ESD) and can be damaged by static electricity. Proper ESD control techniques should be used when handling these devices.

Lead-Free SC70 Plastic Package[†]

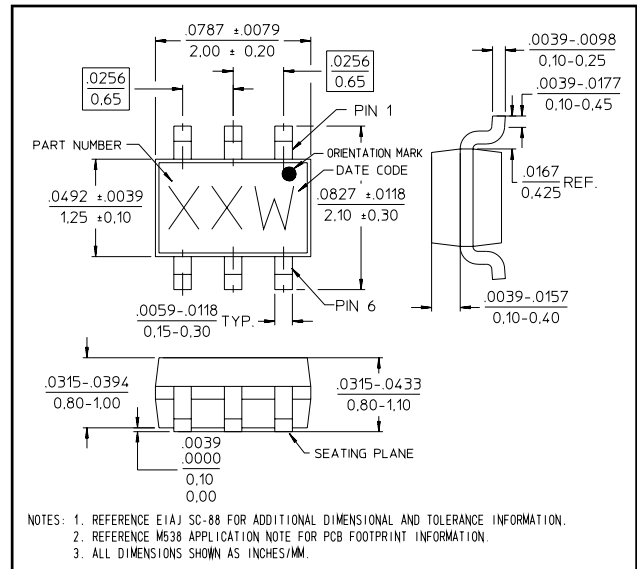

[†] Reference Application Note M538 for lead-free solder reflow recommendations.
Meets JEDEC moisture sensitivity level 1 requirements.
Plating is 100% matte tin over copper.



Компания «ЭлектроПласт» предлагает заключение долгосрочных отношений при поставках импортных электронных компонентов на взаимовыгодных условиях!

Наши преимущества:

- Оперативные поставки широкого спектра электронных компонентов отечественного и импортного производства напрямую от производителей и с крупнейших мировых складов;
- Поставка более 17-ти миллионов наименований электронных компонентов;
- Поставка сложных, дефицитных, либо снятых с производства позиций;
- Оперативные сроки поставки под заказ (от 5 рабочих дней);
- Экспресс доставка в любую точку России;
- Техническая поддержка проекта, помощь в подборе аналогов, поставка прототипов;
- Система менеджмента качества сертифицирована по Международному стандарту ISO 9001;
- Лицензия ФСБ на осуществление работ с использованием сведений, составляющих государственную тайну;
- Поставка специализированных компонентов (Xilinx, Altera, Analog Devices, Intersil, Interpoint, Microsemi, Aeroflex, Peregrine, Syfer, Eurofarad, Texas Instrument, Miteq, Cobham, E2V, MA-COM, Hittite, Mini-Circuits, General Dynamics и др.);

Помимо этого, одним из направлений компании «ЭлектроПласт» является направление «Источники питания». Мы предлагаем Вам помощь Конструкторского отдела:

- Подбор оптимального решения, техническое обоснование при выборе компонента;
- Подбор аналогов;
- Консультации по применению компонента;
- Поставка образцов и прототипов;
- Техническая поддержка проекта;
- Защита от снятия компонента с производства.



Как с нами связаться

Телефон: 8 (812) 309 58 32 (многоканальный)

Факс: 8 (812) 320-02-42

Электронная почта: org@eplast1.ru

Адрес: 198099, г. Санкт-Петербург, ул. Калинина, дом 2, корпус 4, литера А.