

## PIN Diode SPDT 120 Watt Switch for 0.05 - 6.0 GHz Higher Power Applications

Rev. V3

### Features

- Exceptional Broadband Performance
- Low Insertion Loss:  $T_x = 0.20$  dB @ 2.7 GHz
- High Isolation:  $R_x = 50$  dB @ 2.7 GHz
- High  $T_x$  RF Input Power = 120 W C.W. @ 2.0 GHz, 85°C
- Suitable for High Power LTE, TD-SCDMA, WiMAX, and Military Radio Applications
- Surface Mount 4mm PQFN Package
- RoHS\* Compliant and 260°C Reflow Compatible

### Description

The MASW-000936 is a SPDT high power, broadband, high linearity, PIN diode T/R switch for 0.05 – 6.0 GHz applications, including WiMAX & WiFi. The device is provided in an industry standard lead free 4mm PQFN plastic package.

This device incorporates PIN diode die fabricated with M/A-COM Technology Solutions' Low Loss, High Isolation Switching Diode processes.

### Ordering Information<sup>1</sup>

Part Number	Package
MASW-000936-14000T	Tape and Reel (1K)
MASW-000936-001SMB	Sample Board

1. Reference Application Note M513 for reel size information.

### Functional Diagram (Top View)

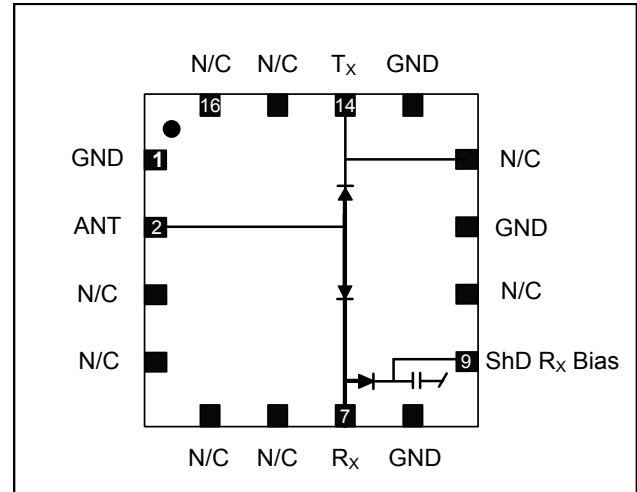

### Pin Configuration<sup>2</sup>

Pin	Pin Name	Description
1	GND	Ground
2	ANT	Antenna
3	N/C	Connect to Ground
4	N/C	No Connection
5	N/C	No Connection
6	N/C	Connect to Ground
7	RX	Receive
8	GND	Ground
9	ShD RX Bias	ShD RX Bias
10	N/C	No Connection
11	GND	Ground
12	N/C <sup>3</sup>	Do Not Use
13	GND	Ground
14	TX	Transmit
15	N/C	Connect to Ground
16	N/C	No Connection

2. The exposed pad centered on the package bottom must be connected to RF, DC and Thermal ground.
3. Do not ground pin 12.

\* Restrictions on Hazardous Substances, European Union Directive 2002/95/EC.

## PIN Diode SPDT 120 Watt Switch for 0.05 - 6.0 GHz Higher Power Applications

Rev. V3

**Electrical Specifications<sup>4</sup>: Freq. = 2.0, 2.7, 3.5 GHz, T<sub>A</sub> = 25°C, Bias = 100 mA / 28 V**

Parameter	Test Conditions	Units	Min.	Typ.	Max.	
Insertion Loss <sup>4</sup> Pin= 0 dBm	R <sub>X</sub> , 0.8 GHz	dB	—	0.20	—	
	T <sub>X</sub> , 0.8 GHz			0.07	—	
	R <sub>X</sub> , 2.0 GHz			0.35	0.55	
	T <sub>X</sub> , 2.0 GHz			0.15	—	
	R <sub>X</sub> , 2.7 GHz			0.50	0.75	
	T <sub>X</sub> , 2.7 GHz			0.20	—	
	R <sub>X</sub> , 3.5 GHz			0.70	0.90	
Isolation <sup>4</sup> Pin= 0 dBm	R <sub>X</sub> to Antenna, 2.0 GHz	dB	41	45	—	
	T <sub>X</sub> to Antenna, 2.0 GHz			16		
	R <sub>X</sub> to Antenna, 2.7 GHz			40		50
	T <sub>X</sub> to Antenna, 2.7 GHz			—		13
	R <sub>X</sub> to Antenna, 3.5 GHz			33		40
	T <sub>X</sub> to Antenna, 3.5 GHz			—		11
Input Return Loss <sup>4</sup> Pin= 0 dBm	R <sub>X</sub>	dB	—	23	—	
	T <sub>X</sub>			34		
T <sub>X</sub> Input P0.1dB	T <sub>X</sub> to Antenna	dBm	—	>50	—	
T <sub>X</sub> IIP3 Pin = +30 dBm	F1 = 2010 MHz, F2 = 2020 MHz	dBm	—	72	—	
T <sub>X</sub> C.W. Input Power	85°C Base plate	dBm / W	—	50.8 / 120	—	
	2.0 GHz			50 / 100		
	2.7 GHz			49 / 80		
R <sub>X</sub> C.W. Input Power	—	dBm	—	41.5	—	
		W		14		
T <sub>X</sub> RF Switching Speed	( 10-90% RF Voltage) 1 MHz Rep Rate in Modulating Mode	ns	—	200	—	

4. See Bias Table

### Absolute Maximum Ratings<sup>5,6</sup>

@ T<sub>A</sub> = +25 °C (unless otherwise specified)

Parameter	Absolute Maximum
Forward Current	150 mA
Reverse Voltage ( RF & D.C. )	160 V
Operating Temperature	-40 °C to +85 °C
Storage Temperature	-55 °C to +150 °C
Junction Temperature	+175 °C
T <sub>X</sub> Incident C.W. Power	50.8 dBm (120 W) <sup>7</sup> @ 2.0 GHz, 85°C

5. Exceeding these limits may cause permanent damage.
6. M/A-COM Technology Solutions does not recommend sustained operation near these survivability limits.
7. Base-plate temperature must be controlled to a constant +85°C.

### Handling Procedures

Please observe the following precautions to avoid damage:

### Static Sensitivity

Silicon Integrated Circuits are sensitive to electrostatic discharge (ESD) and can be damaged by static electricity. Proper ESD control techniques should be used when handling these Class 1C Human Body devices.

## PIN Diode SPDT 120 Watt Switch for 0.05 - 6.0 GHz Higher Power Applications

Rev. V3

### Bias Diagrams & Tables

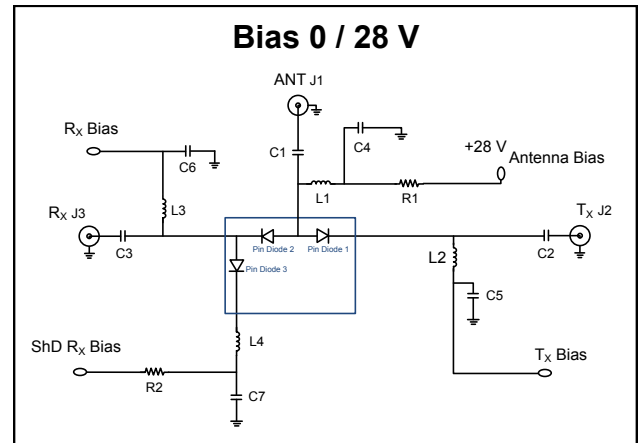
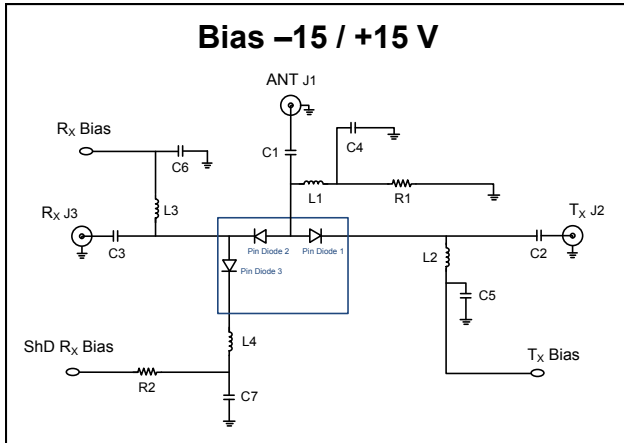

### Bias -15 / +15 V

Bias Table	T <sub>x</sub>	R <sub>x</sub>	R <sub>x</sub> ShDBias	ANT
Pin	Pin 14	Pin 7	Pin 9	Pin 2
T <sub>x</sub> -ANT Isolation	(+15 V), 0 mA	(-15 V), -100 mA	GND	GND
T <sub>x</sub> -ANT Insertion Loss	(-15 V), -100 mA	(+15 V), 100 mA	GND	GND
R <sub>x</sub> -ANT Isolation	(-15 V), -100 mA	(+15 V), 100 mA	GND	GND
R <sub>x</sub> -ANT Insertion Loss	(+15 V), 0 mA	(-15 V), 100 mA	GND	GND

### Bias 0 / 28 V

Bias Table	T <sub>x</sub>	R <sub>x</sub>	R <sub>x</sub> ShDBias	ANT
Pin	Pin 14	Pin 7	Pin 9	Pin 2
T <sub>x</sub> -ANT Isolation	(+28 V), 0 mA	(GND), -100 mA	(+28 V), 0 mA	+28 V
T <sub>x</sub> -ANT Insertion Loss	(GND), -100 mA	(+28 V), 100 mA	(GND), -100 mA	+28 V
R <sub>x</sub> -ANT Isolation	(GND), -100 mA	(+28 V), 100 mA	(GND), -100 mA	+28 V
R <sub>x</sub> -ANT Insertion Loss	(+28 V), 0 mA	(GND), -100 mA	(+28 V), 0 mA	+28 V

**Typical Performance Curves (RF-probed parts),  
 $T_x$  (100 mA Bias Current)**

**Insertion Loss,  $T_x$**

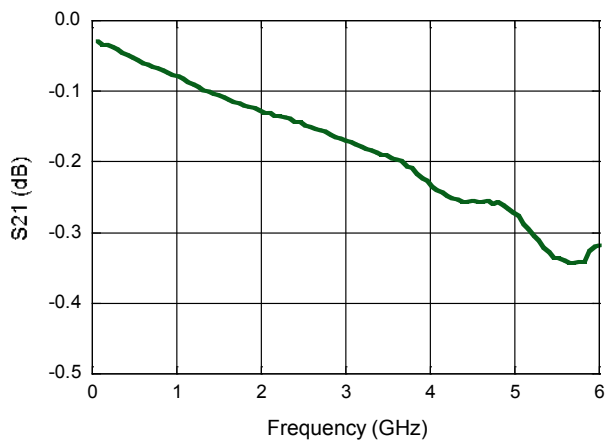

**Isolation,  $T_x$**

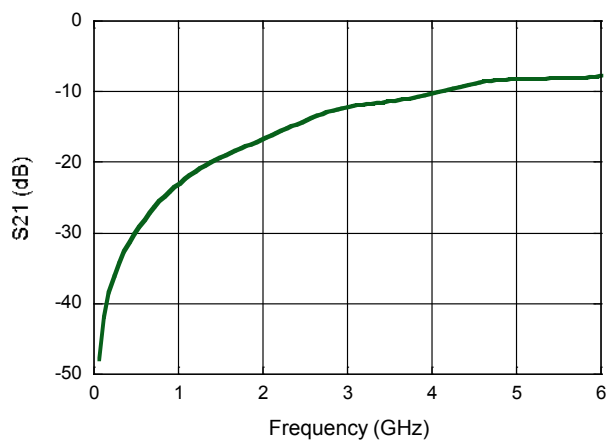

**Input Return Loss,  $T_x$**

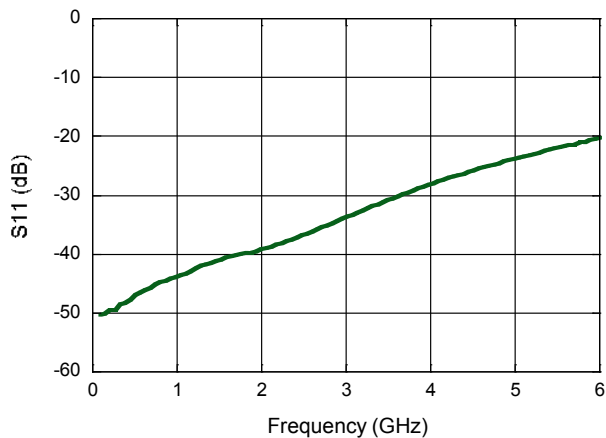

**Output Return Loss,  $T_x$**

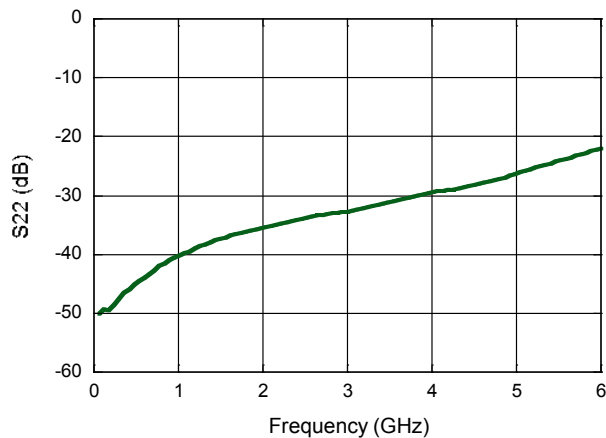

**Typical Performance Curves (RF-probed parts),  
R<sub>x</sub> (100 mA Bias Current)**

**Insertion Loss, R<sub>x</sub>**

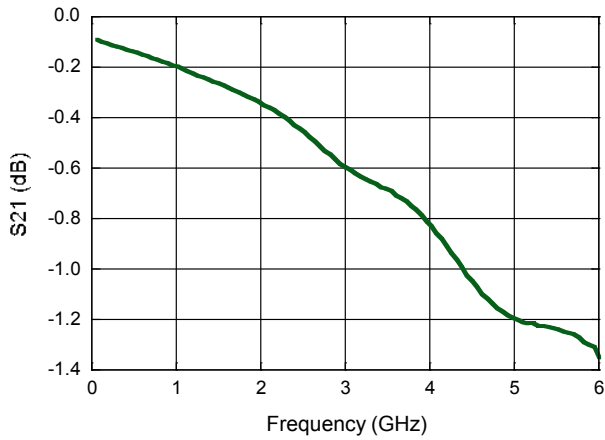

**Isolation, R<sub>x</sub>**

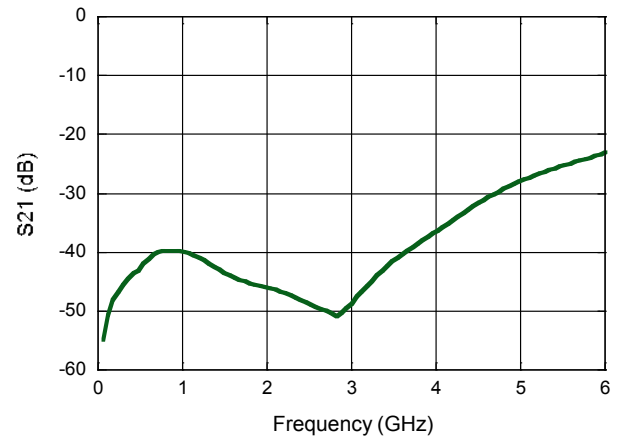

**Input Return Loss, R<sub>x</sub>**

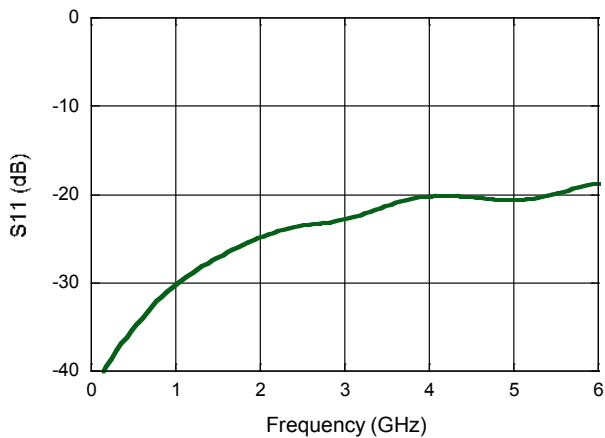

**Output Return Loss, R<sub>x</sub>**

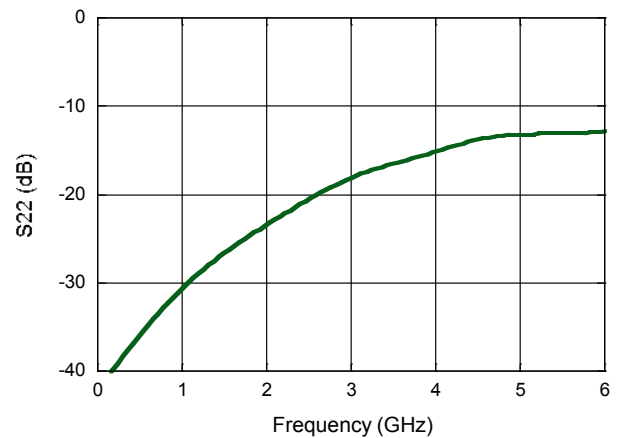

## PIN Diode SPDT 120 Watt Switch for 0.05 - 6.0 GHz Higher Power Applications

Rev. V3

### Application Schematic<sup>8</sup>

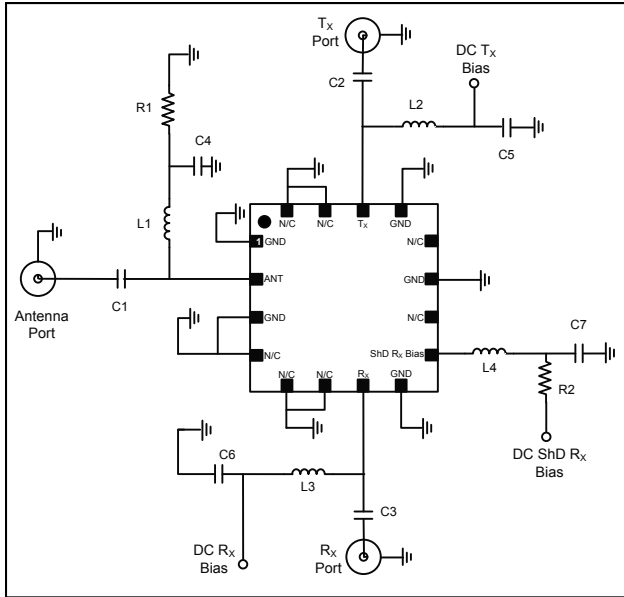

### Parts List

Component	Value	Package
C1-C3	22 pF	0603
C4-C6	27 pF	0603
L1-L4	68 nH	0603
R1, R2	137 $\Omega$	0603

8. Adding an LC network to pin 12 can improve  $R_x$  performance between 2.0 and 2.7 GHz but may limit performance above 3 GHz. For broadband applications M/A-COM Technology Solutions recommends not using pin 12 and not connecting it to any metal trace.

### PCB Footprint

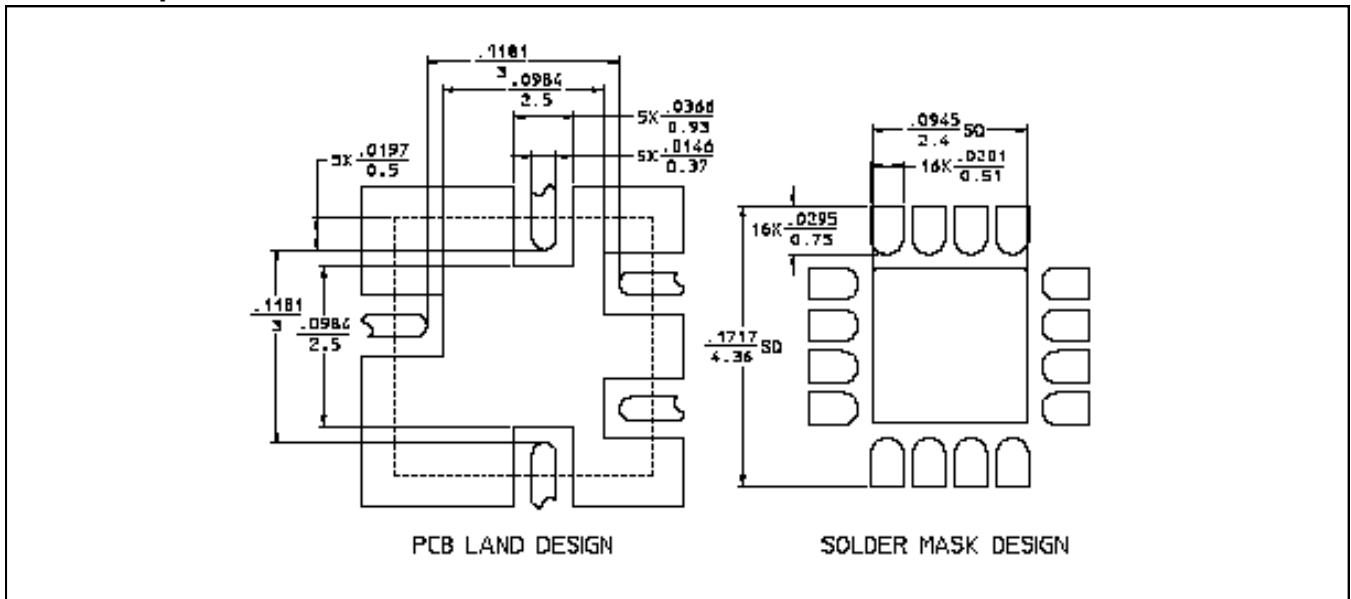

## PIN Diode SPDT 120 Watt Switch for 0.05 - 6.0 GHz Higher Power Applications

Rev. V3

### Lead Free 4 mm 16-Lead PQFN †

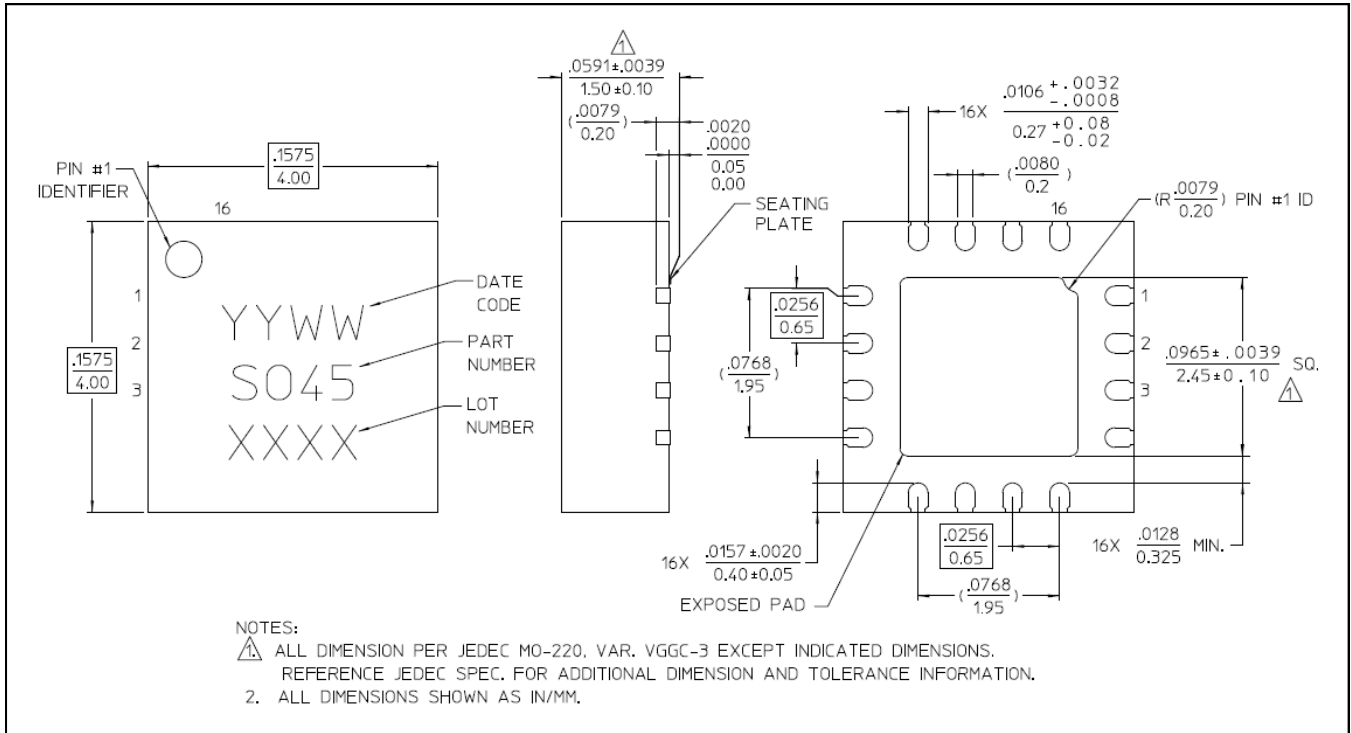

† Reference Application Note S2083 for lead-free solder reflow recommendations.  
Meets JEDEC moisture sensitivity level 1 requirements.  
Plating is NiPdAuAg.

M/A-COM Technology Solutions Inc. All rights reserved.

Information in this document is provided in connection with M/A-COM Technology Solutions Inc ("MACOM") products. These materials are provided by MACOM as a service to its customers and may be used for informational purposes only. Except as provided in MACOM's Terms and Conditions of Sale for such products or in any separate agreement related to this document, MACOM assumes no liability whatsoever. MACOM assumes no responsibility for errors or omissions in these materials. MACOM may make changes to specifications and product descriptions at any time, without notice. MACOM makes no commitment to update the information and shall have no responsibility whatsoever for conflicts or incompatibilities arising from future changes to its specifications and product descriptions. No license, express or implied, by estoppel or otherwise, to any intellectual property rights is granted by this document.

THESE MATERIALS ARE PROVIDED "AS IS" WITHOUT WARRANTY OF ANY KIND, EITHER EXPRESS OR IMPLIED, RELATING TO SALE AND/OR USE OF MACOM PRODUCTS INCLUDING LIABILITY OR WARRANTIES RELATING TO FITNESS FOR A PARTICULAR PURPOSE, CONSEQUENTIAL OR INCIDENTAL DAMAGES, MERCHANTABILITY, OR INFRINGEMENT OF ANY PATENT, COPYRIGHT OR OTHER INTELLECTUAL PROPERTY RIGHT. MACOM FURTHER DOES NOT WARRANT THE ACCURACY OR COMPLETENESS OF THE INFORMATION, TEXT, GRAPHICS OR OTHER ITEMS CONTAINED WITHIN THESE MATERIALS. MACOM SHALL NOT BE LIABLE FOR ANY SPECIAL, INDIRECT, INCIDENTAL, OR CONSEQUENTIAL DAMAGES, INCLUDING WITHOUT LIMITATION, LOST REVENUES OR LOST PROFITS, WHICH MAY RESULT FROM THE USE OF THESE MATERIALS.

MACOM products are not intended for use in medical, lifesaving or life sustaining applications. MACOM customers using or selling MACOM products for use in such applications do so at their own risk and agree to fully indemnify MACOM for any damages resulting from such improper use or sale.





Компания «ЭлектроПласт» предлагает заключение долгосрочных отношений при поставках импортных электронных компонентов на взаимовыгодных условиях!

Наши преимущества:

- Оперативные поставки широкого спектра электронных компонентов отечественного и импортного производства напрямую от производителей и с крупнейших мировых складов;
- Поставка более 17-ти миллионов наименований электронных компонентов;
- Поставка сложных, дефицитных, либо снятых с производства позиций;
- Оперативные сроки поставки под заказ (от 5 рабочих дней);
- Экспресс доставка в любую точку России;
- Техническая поддержка проекта, помощь в подборе аналогов, поставка прототипов;
- Система менеджмента качества сертифицирована по Международному стандарту ISO 9001;
- Лицензия ФСБ на осуществление работ с использованием сведений, составляющих государственную тайну;
- Поставка специализированных компонентов (Xilinx, Altera, Analog Devices, Intersil, Interpoint, Microsemi, Aeroflex, Peregrine, Syfer, Eurofarad, Texas Instrument, Miteq, Cobham, E2V, MA-COM, Hittite, Mini-Circuits, General Dynamics и др.);

Помимо этого, одним из направлений компании «ЭлектроПласт» является направление «Источники питания». Мы предлагаем Вам помощь Конструкторского отдела:

- Подбор оптимального решения, техническое обоснование при выборе компонента;
- Подбор аналогов;
- Консультации по применению компонента;
- Поставка образцов и прототипов;
- Техническая поддержка проекта;
- Защита от снятия компонента с производства.



#### Как с нами связаться

**Телефон:** 8 (812) 309 58 32 (многоканальный)

**Факс:** 8 (812) 320-02-42

**Электронная почта:** [org@eplast1.ru](mailto:org@eplast1.ru)

**Адрес:** 198099, г. Санкт-Петербург, ул. Калинина, дом 2, корпус 4, литера А.