

Future Technology Devices International Ltd Datasheet TTL-232R-RPi Debug Cable for Raspberry Pi Datasheet



The TTL-232R-RPi cable provides USB to TTL Level UART solutions and is customised for operation with the Raspberry Pi.

1 Introduction

TTL-232R-RPi is a USB to TTL level serial UART converter cables incorporating FTDI's FT232RQ USB to Serial UART interface IC device which handles all the USB signalling and protocols. The TTL-232R-RPi is designed for use with the Raspberry Pi (RPi), an ultra-low cost, Linux based miniaturised computer. The debug cable sits on the Rx/Tx of the RPi ARM processor UART – which provides much more detail of what's happening within the RPi operating system. Connecting the debug cable to a PC and communicating with the RPi via a terminal emulator on a PC gives the user access to more detailed information from the Linux kernel during RPi start-up, which appears on the Rx/TX lines of the UART, as well as being able to login and access the kernel itself from the PC.

1.1 Features

- TTL-232R-RPi Debug cable provides a USB to TTL Serial interface for Raspberry Pi computer.
- On board FT232RQ provides single chip USB to asynchronous serial data transfer interface.
- Entire USB protocol handled by the electronics in the cable USB.
- Connect directly to a microcontroller UART or I/O pins.
- UART interface support for 7 or 8 data bits, 1 or 2 stop bits and odd / even / mark / space / no parity.
- Fully assisted or X-On / X-Off software handshaking.
- Data transfer rates from 300 baud to 3 Mbaud at TTL levels.
- Internal EEPROM with user writeable area.
- 5V safe TTL inputs make the TTL-232R easy to interface to 5V MCU's.
- FTDI's royalty-free VCP allow for communication as a standard emulated COM port and D2XX 'direct' drivers provide DLL application programming interface.
- Support for FT232R FTDIChip-ID™ feature for improved security.
- 3x 'flying leads' outputs provide TXD, RXD and GND signals.
- Low USB bandwidth consumption.
- UHCI / OHCI / EHCI host controller compatible.
- USB 2.0 Full Speed compatible.
- -40°C to +85°C operating temperature range.
- Cable length is 1.0m.
- FCC and CE compliant.

1.2 Ordering Information

Part Number	Description
TTL-232R-RPi	USB to UART, 3.3V TTL logic level, Raspberry Pi compatible flying leads

Table 1-1 – USB-RS232 Adapter Ordering Information

Table of Contents

1	Introduction	1
1.1	Features.....	1
1.2	Ordering Information.....	2
2	Driver Support.....	4
2.1	Driver Operation Examples	4
3	Operational Descriptions	5
4	Functional Descriptions	5
4.1	TTL-232R-RPi Wire Configuration	5
4.2	TTL-232R-RPi Debug cable Signal Descriptions.....	6
4.3	TTL-232R-RPi Debug cable Electrical Parameters.....	6
5	TTL-232R-RPi Debug cable connection diagram	7
6	Advanced Features of the TTL-232R-RPi.....	7
7	TTL-232R-RPi Circuit Schematic	8
8	Internal EEROM Configuration.....	9
9	Contact Information	10
	Appendix A – List of Tables and Figures.....	10
	Appendix B – Revision History	11

2 Driver Support

Royalty-Free VIRTUAL COM PORT (VCP) DRIVERS for:

- Windows 7 32,64-bit
- Windows Vista
- Windows XP 32,64-bit
- Windows XP Embedded
- Windows CE.NET 4.2 , 5.0 and 6.0
- MAC OS OS-X
- Linux 2.6.32 or later
- ARM Linux
- Android

Royalty-Free D2XX Direct Drivers (USB Drivers + DLL S/W Interface):

- Windows 7 32,64-bit
- Windows Vista
- Windows XP 32,64-bit
- Windows XP Embedded
- Windows CE.NET 4.2, 5.0 and 6.0
- MAC OS OS-X
- Linux 2.6.32 or later
- ARM Linux
- Android

The drivers listed above are all available to download for free from www.ftdichip.com. Various 3rd Party Drivers are also available for various other operating systems - visit www.ftdichip.com for details.

For driver installation instructions please see:

<http://www.ftdichip.com/Support/Documents/InstallGuides.htm>.

2.1 Driver Operation Examples

The TTL-232R-RPi debug cables require USB drivers, available free from <http://www.ftdichip.com>, which are used to make the FT232R in the cable appear as a virtual COM port (VCP). This then allows the user to communicate with the USB interface via a standard PC serial emulation port (for example TTY). Another FTDI USB driver, the D2XX driver, can also be used with application software to directly access the FT232R on the cable though a DLL. This is illustrated in the Figure 2-1.

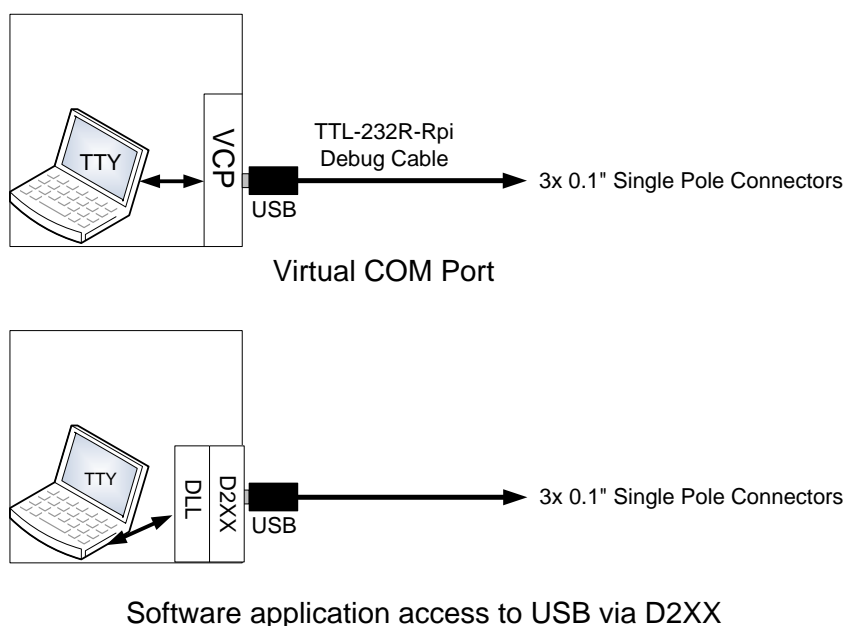

Figure 2-1 – Using the TTL-232R-RPi Generic Cable

3 Operational Descriptions

TTL-232R-RPi is a USB-to-TTL Serial UART debug cable. It is designed to be used with the Raspberry Pi (RPi) Linux-based computer. This cable provides a fast, simple way for a PC to interface with an RPi, to carry out program analysis and debugging.

This cable is electrically configured to process and drive +3.3 V logic level UART signals. The USB side of the cable is USB powered and USB 2.0 Full Speed compatible, supporting data transfer rates up to 3 Mbaud. Spanning 1.0m in length, the TTL-232R-RPi debug cable connects directly to the serial port on the RPi board. The RPi's serial port can output kernel debug messages even if it has not been completely booted.

The following serial communication parameters should be used to access the serial/debugger port on Raspberry Pi board:

- * Speed: 115200 baud
- * Bits: 8
- * Parity: None
- * Stop Bits: 1
- * Flow Control: None

For more information about the Raspberry Pi Computer refer to the Raspberry Pi Foundation web site:

<http://www.raspberrypi.org/>

4 Functional Descriptions

4.1 TTL-232R-RPi Wire Configuration

The following Figure 4-1 shows the cable signals and the wire colours for these signals on the TTL-232R-RPi generic cables.

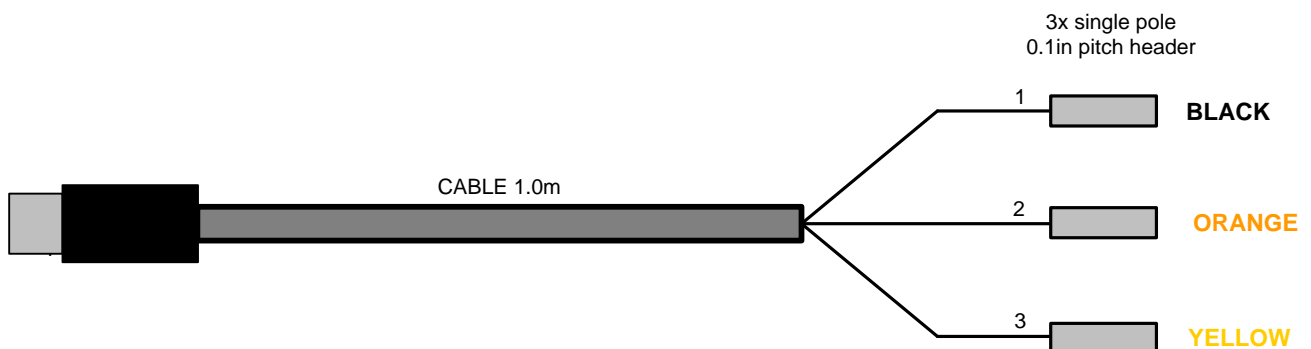

Figure 4-1 – TTL-232R-RPi Debug cable Pin Out

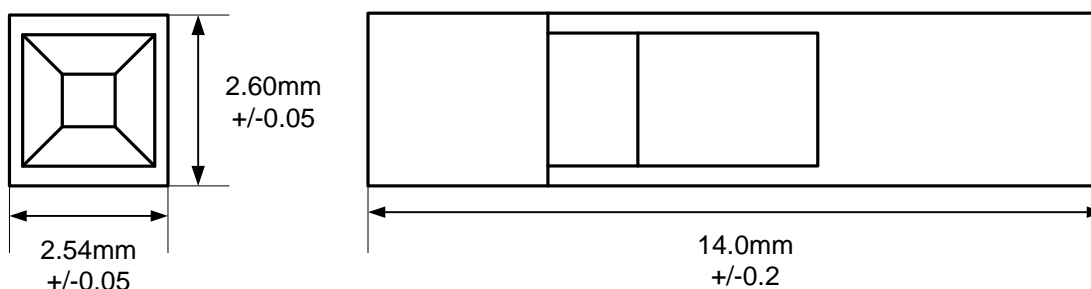

Figure 4-2 – TTL-232R-RPi Debug cable, Single Pole Header Mechanical Details

4.2 TTL-232R-RPi Debug cable Signal Descriptions

Header Pin Number	Name	Type	Colour	Description
1	GND	GND	Black	Device ground supply pin. Connect to ground pin on RPi board
2	TXD	Output	Orange	Transmit Asynchronous Data output. Connect to RXD input on RPi board
3	RXD	Input	Yellow	Receive Asynchronous Data input. Connect to TXD output on RPi board

Table 4-1 – TTL-232R-RPi Debug cable Signal Descriptions

4.3 TTL-232R-RPi Debug cable Electrical Parameters

Parameter	Description	Minimum	Typical	Maximum	Units	Conditions
VCC	Power Input Voltage	4.25	5.0	5.25	V	Dependant on the USB port that the TTL-232R-RPi Debug cable is connected to
I _o	Power Input Current	-	-	15	mA	Less than 70uA during suspend.
T	Operating Temperature Range	-40	-	+85	°C	

Table 4-2 – TTL-232R-RPi Debug cable Operating Parameters

Parameter	Description	Minimum	Typical	Maximum	Units	Conditions
V _{oh}	Output Voltage High	2.2	2.8	3.2	V	I source = 3mA
V _{ol}	Output Voltage Low	0.3	0.4	0.6	V	I sink = 8mA
V _{in}	Input Switching Threshold	1.0	1.2	1.5	V	
V _{hys}	Input Switching Hysteresis	20	25	30	mV	

Table 4-3 – TTL-232R- RPi Debug cable I/O Pin Characteristics

5 TTL-232R-RPi Debug cable connection diagram

The TTL-232R-RPi Debug cable should be connected to Raspberry Pi board according to the diagram below.

Please note that TXD-orange wire should be connected to RX pin on RPi board and RXD-yellow wire should be connected to TX pin on RPi board.

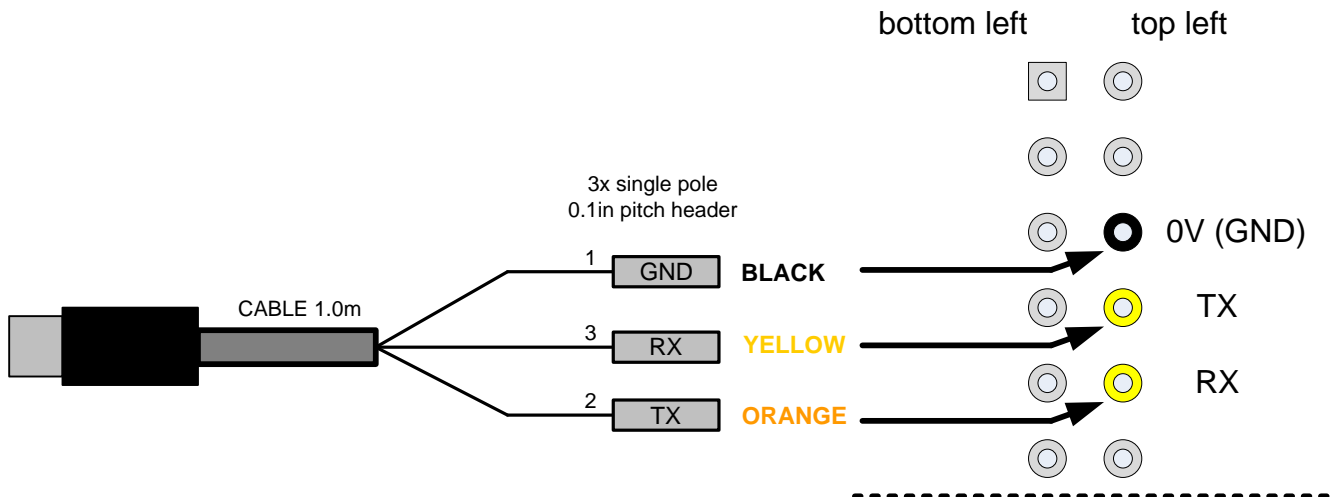

Figure 5-1 – TTL-232R-RPi Debug cable, connection diagram

6 Advanced Features of the TTL-232R-RPi

The TTL-232R-RPi debug cable utilizes FTDI's FT232RQ USB to serial IC device. This section summarises the key features of the FT232RQ which apply to the TTL-232R-RPi debug cables. For further details, and a full features and enhancements description consult the FT232R datasheet, this is available from www.ftdichip.com.

Internal EEPROM. The internal EEPROM in each cable is used to store USB Vendor ID (VID), Product ID (PID), device serial number, product description string and various other USB configuration descriptors. Each cable is supplied with the internal EEPROM pre-programmed as described

Lower Operating and Suspend Current. The FT232R has a low 15mA operating supply current and a very low USB suspend current of approximately 70µA.

Low USB Bandwidth Consumption. The USB interface of the FT232R, and therefore the TTL-232R cables has been designed to use as little as possible of the total USB bandwidth available from the USB host controller.

High Output Drive Option. The UART interface I/O pins on the TTL-232R-RPi Debug cable (RXD and TXD) can be configured to use the FT232R's high output drive option. This option allows the FT232R I/O pins to drive up to three times the standard signal drive level. This allows multiple devices to be driven, or devices that require greater signal drive strength to be interfaced to the cables. This option is enabled in the internal EEPROM.

UART Pin Signal Inversion. The sense of UART signals can be individually inverted by configuring options in the internal EEPROM. For example RXD (active high) can be changed to RXD# (active low) and TXD can be changed to TXD#.

FTDICHIP-ID™. The FT232R includes the new FTDICHIP-ID™ security dongle feature. This FTDICHIP-ID™ feature allows a unique number to be burnt into each cable during manufacture. This number cannot be reprogrammed. An application note, [AN232R-02](#), available from [FTDI website \(www.ftdichip.com\)](http://www.ftdichip.com) describes this feature.

7 TTL-232R-RPi Circuit Schematic

The circuit schematic for the small internal electronic circuit board, utilising the FTDI FT232R, which is encapsulated into the USB connector end of the cable, is shown in Figure 7-1.

Customised versions of these cables are also available. Users interested in customised versions of these cables should contact [FTDI sales \(sales1@ftdichip.com\)](mailto:sales1@ftdichip.com).

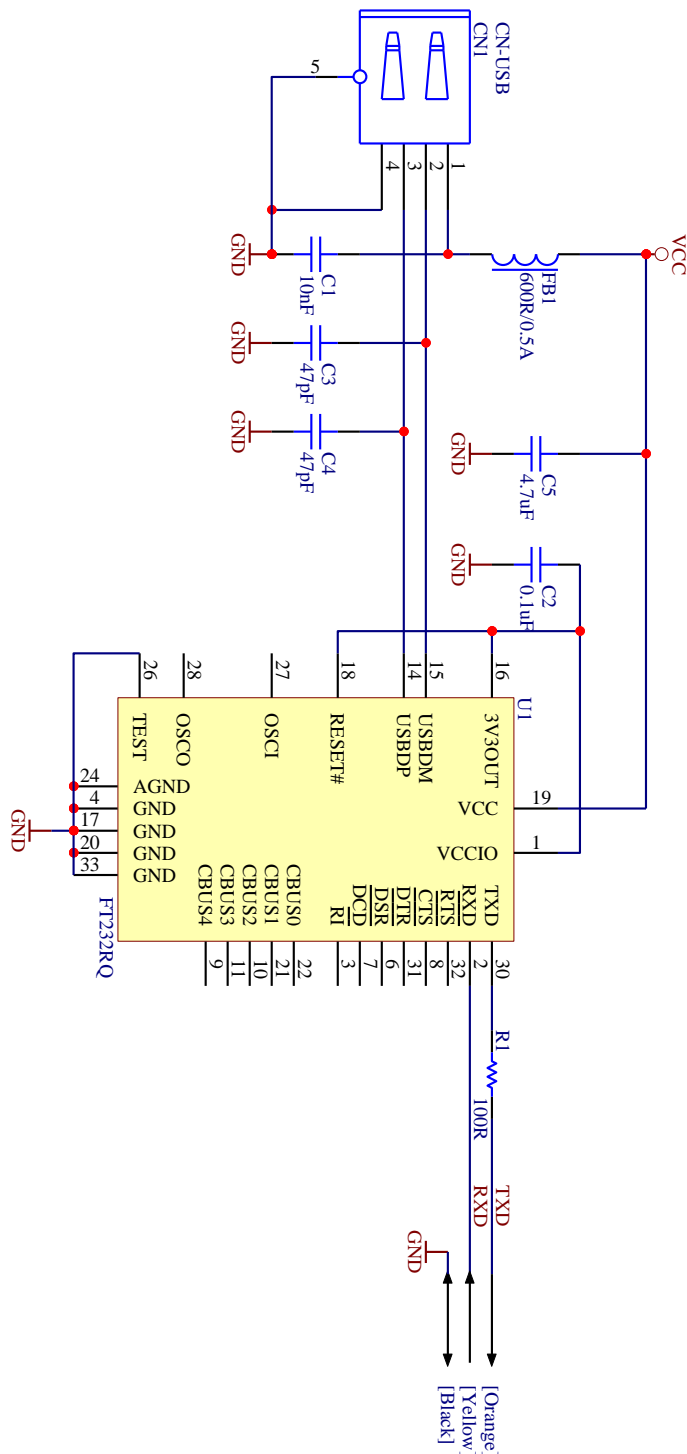

Figure 7-1 – Circuit Schematic of PCB Used in the TTL 232R-RPi Debug cable

8 Internal EEPROM Configuration

The TTL-232R-RPi Debug cable is controlled by the FTDI FT232R IC. This FT232R device contains an EEPROM which contains the USB configuration descriptors for that device. When the cable is plugged into a PC or a USB reset is performed, the PC will read these descriptors. The default values stored into the internal EEPROM are defined in Table 8.1.

Parameter	Value	Notes
USB Vendor ID (VID)	0403h	FTDI default VID (hex)
USB Product ID (PID)	6001h	FTDI default PID (hex)
Serial Number Enabled?	Yes	
Serial Number	See Note	A unique serial number is generated and programmed into the EEPROM during device final test.
Pull down I/O Pins in USB Suspend	Disabled	Enabling this option will make the device pull down on the UART interface lines when the power is shut off (PWREN# is high).
Manufacturer Name	FTDI	
Product Description	TTL232R-3V3	
Max Bus Power Current	90mA	
Power Source	Bus Powered	
Device Type	FT232R	
USB Version	0200	Returns USB 2.0 device description to the host.
Remote Wake Up	Disabled	
High Current I/Os	Enabled	Enables the high drive level on the UART and CBUS I/O pins.
Load VCP Driver	Enabled	Makes the device load the VCP driver interface for the device.
Invert TXD	Disabled	Signal on this pin becomes TXD# if enable.
Invert RXD	Disabled	Signal on this pin becomes RXD# if enable.
Invert RTS#	Disabled	Signal on this pin becomes RTS if enable.
Invert CTS#	Disabled	Signal on this pin becomes CTS if enable.

Table 8-1 – Default Internal EEPROM Configuration

The internal EEPROM in the cable can be re-programmed over USB using the utility program [FT_PROG](#). [FT_PROG](#) can be downloaded from the www.ftdichip.com.



9 Contact Information

Head Office – Glasgow, UK

Future Technology Devices International Limited
Unit 1, 2 Seaward Place, Centurion Business Park
Glasgow G41 1HH
United Kingdom
Tel: +44 (0) 141 429 2777
Fax: +44 (0) 141 429 2758

E-mail (Sales) sales1@ftdichip.com
E-mail (Support) support1@ftdichip.com
E-mail (General Enquiries) admin1@ftdichip.com

Branch Office – Hillsboro, Oregon, USA

Future Technology Devices International Limited (USA)
7235 NW Evergreen Parkway, Suite 600
Hillsboro, OR 97123-5803
USA
Tel: +1 (503) 547 0988
Fax: +1 (503) 547 0987

E-Mail (Sales) us.sales@ftdichip.com
E-Mail (Support) us.support@ftdichip.com
E-Mail (General Enquiries) us.admin@ftdichip.com

Branch Office – Taipei, Taiwan

Future Technology Devices International Limited (Taiwan)
2F, No. 516, Sec. 1, NeiHu Road
Taipei 114
Taiwan, R.O.C.
Tel: +886 (0) 2 8791 3570
Fax: +886 (0) 2 8791 3576

E-mail (Sales) asia.sales1@ftdichip.com
E-mail (Support) asia.support1@ftdichip.com
E-mail (General Enquiries) asia.admin1@ftdichip.com

Branch Office – Shanghai, China

Future Technology Devices International Limited (China)
Room 1103, No. 666,
West Huaihai Road,
Shanghai, 200052
China
Tel: +86 21 62351596
Fax: +86 21 62351595

E-mail (Sales) cn.sales@ftdichip.com
E-mail (Support) cn.support@ftdichip.com
E-mail (General Enquiries) cn.admin@ftdichip.com

Web Site

<http://ftdichip.com>

Distributor and Sales Representatives

Please visit the Sales Network page of the [FTDI Web site](#) for the contact details of our distributor(s) and sales representative(s) in your country.

System and equipment manufacturers and designers are responsible to ensure that their systems, and any Future Technology Devices International Ltd (FTDI) devices incorporated in their systems, meet all applicable safety, regulatory and system-level performance requirements. All application-related information in this document (including application descriptions, suggested FTDI devices and other materials) is provided for reference only. While FTDI has taken care to assure it is accurate, this information is subject to customer confirmation, and FTDI disclaims all liability for system designs and for any applications assistance provided by FTDI. Use of FTDI devices in life support and/or safety applications is entirely at the user's risk, and the user agrees to defend, indemnify and hold harmless FTDI from any and all damages, claims, suits or expense resulting from such use. This document is subject to change without notice. No freedom to use patents or other intellectual property rights is implied by the publication of this document. Neither the whole nor any part of the information contained in, or the product described in this document, may be adapted or reproduced in any material or electronic form without the prior written consent of the copyright holder. Future Technology Devices International Ltd, Unit 1, 2 Seaward Place, Centurion Business Park, Glasgow G41 1HH, United Kingdom. Scotland Registered Company Number: SC136640

Appendix A – List of Tables and Figures

List of Figures

Figure 2-1 – Using the TTL-232R-RPi Generic Cable	4
Figure 4-1 – TTL-232R-RPi Debug cable Pin Out	5
Figure 4-2 – TTL-232R-RPi Debug cable, Single Pole Header Mechanical Details	5
Figure 5-1 – TTL-232R-RPi Debug cable, connection diagram	7
Figure 7-1 – Circuit Schematic of PCB Used in the TTL 232R-RPi Debug cable	8

List of Tables

Table 1-1 – USB-RS232 Adapter Ordering Information	2
Table 4-1 – TTL-232R-RPi Debug cable Signal Descriptions	6
Table 4-2 – TTL-232R-RPi Debug cable Operating Parameters	6
Table 4-3 – TTL-232R- RPi Debug cable I/O Pin Characteristics	6
Table 8-1 – Default Internal EEPROM Configuration	9

Appendix B – Revision History

Document Title: DS_TTL-232R-RPi
Document Reference No.: FT_000722
Clearance No.: FTDI# 296
Product Page: <http://www.ftdichip.com/Products/Cables/USBTTLSerial.htm>
Document Feedback: [Send Feedback](#)

Version 1.0 Initial Datasheet Released 15/06/12



Компания «ЭлектроПласт» предлагает заключение долгосрочных отношений при поставках импортных электронных компонентов на взаимовыгодных условиях!

Наши преимущества:

- Оперативные поставки широкого спектра электронных компонентов отечественного и импортного производства напрямую от производителей и с крупнейших мировых складов;
- Поставка более 17-ти миллионов наименований электронных компонентов;
- Поставка сложных, дефицитных, либо снятых с производства позиций;
- Оперативные сроки поставки под заказ (от 5 рабочих дней);
- Экспресс доставка в любую точку России;
- Техническая поддержка проекта, помощь в подборе аналогов, поставка прототипов;
- Система менеджмента качества сертифицирована по Международному стандарту ISO 9001;
- Лицензия ФСБ на осуществление работ с использованием сведений, составляющих государственную тайну;
- Поставка специализированных компонентов (Xilinx, Altera, Analog Devices, Intersil, Interpoint, Microsemi, Aeroflex, Peregrine, Syfer, Eurofarad, Texas Instrument, Miteq, Cobham, E2V, MA-COM, Hittite, Mini-Circuits, General Dynamics и др.);

Помимо этого, одним из направлений компании «ЭлектроПласт» является направление «Источники питания». Мы предлагаем Вам помощь Конструкторского отдела:

- Подбор оптимального решения, техническое обоснование при выборе компонента;
- Подбор аналогов;
- Консультации по применению компонента;
- Поставка образцов и прототипов;
- Техническая поддержка проекта;
- Защита от снятия компонента с производства.



Как с нами связаться

Телефон: 8 (812) 309 58 32 (многоканальный)

Факс: 8 (812) 320-02-42

Электронная почта: org@eplast1.ru

Адрес: 198099, г. Санкт-Петербург, ул. Калинина, дом 2, корпус 4, литера А.