

THIS DRAWING IS UNPUBLISHED. RELEASED FOR PUBLICATION  
 © COPYRIGHT - - ALL RIGHTS RESERVED.

REVISIONS					
P	LTR	DESCRIPTION	DATE	DWN	APVD
3		modify the packaging specific	03AUG2018	E.Z	W.H

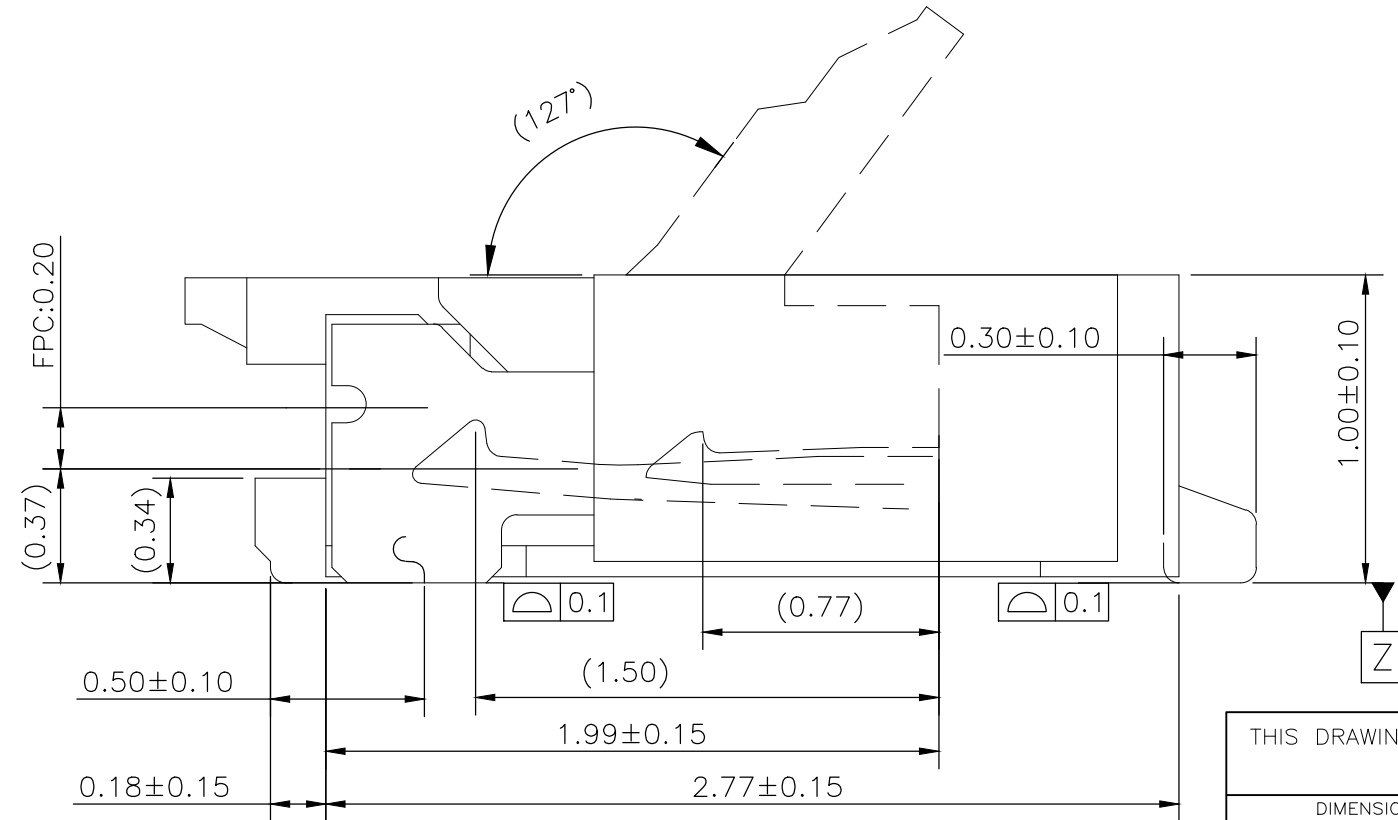
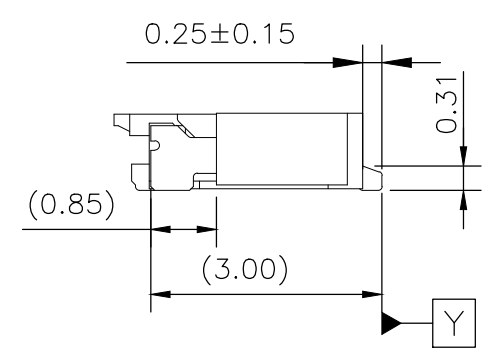
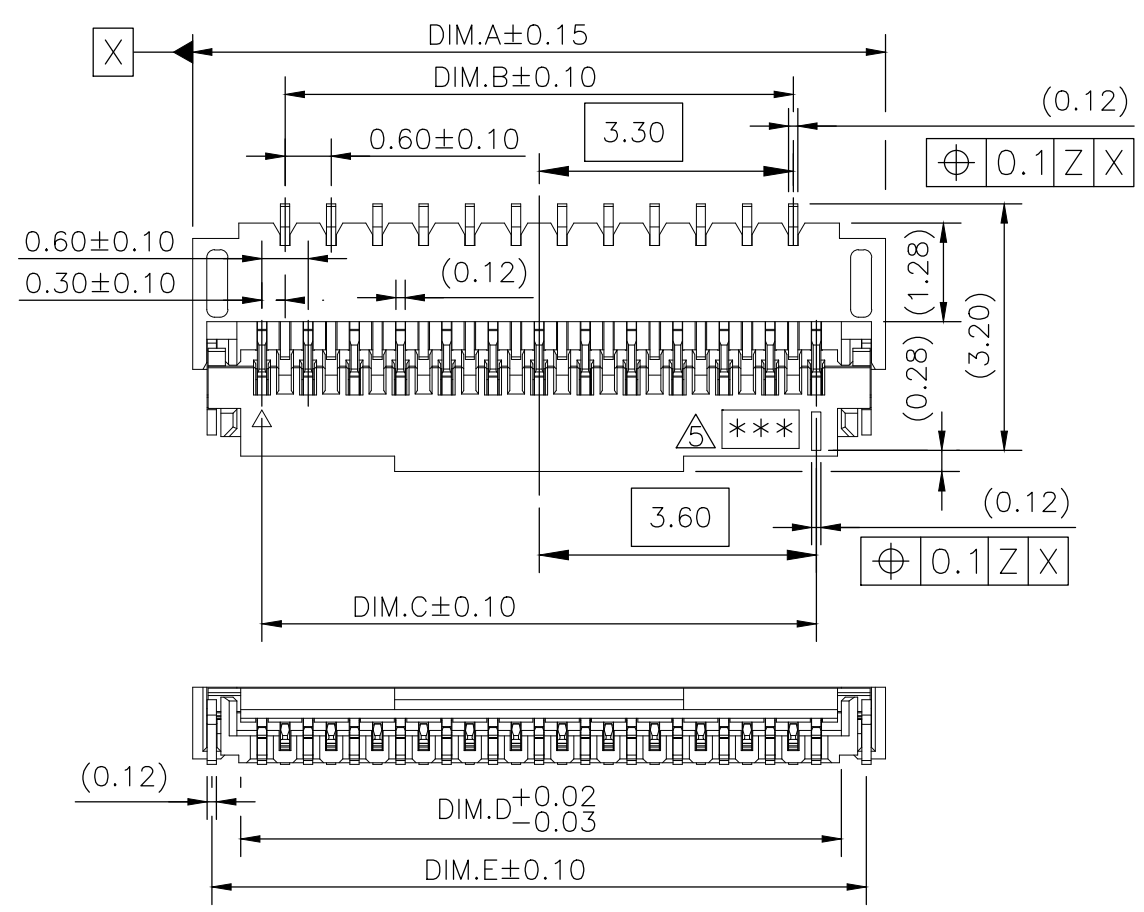

- NOTES:
- MATERIAL:
    - HOUSING : HIGH TEMPERATURE THERMOPLASTIC UL94V-0, COLOR: NATURAL.
    - ACTUATOR: HIGH TEMPERATURE THERMOPLASTIC UL94V-HB, COLOR: BLACK.
    - CONTACT: COPPER ALLOY.
    - FITTING NAIL : COPPER ALLOY.
  - FINISH:
    - CONTACT: GOLD PLATING 3u" MIN. ON CONTACT AREA. GOLD PLATING 1u" MIN. ON SOLDER TAILS. 50u"MIN. NICKEL UNDERPLATING OVERALL.
    - FITTING NAIL: TIN PLATING 80u" MIN. ON SOLDER TAILS. 50u" MIN. NICKEL UNDERPLATING OVERALL.
  - SPECIFICATION:
 

VOLTAGE: 30V AC/DC  
 CURRENT RATING: 0.5 AMPERE  
 CONTACT RESISTANCE: INITIAL 50 mOHMS MAX. AFTER TEST Δ30 mOHMS MAX.  
 DIELECTRIC WITHSTANDING VOLTAGE: 250V AC/1 MINUTE;  
 INSULATION RESISTANCE: 500M OHMS MIN.  
 FFC/FPC WITHDRAWL FORCE: 0.20N PER CONTACT MIN;  
 FFC/FPC THICKNESS: 0.20+/-0.03mm.
  - THE PRODUCT IS RoHS AND HF COMPLIANT.
- ⚠ PIN NO.

45	13.8	14.5	13.85	13.2	12.6	15.0	4-2328724-5
39	12.0	12.7	12.05	11.4	10.8	13.2	3-2328724-9
33	10.2	10.9	10.25	9.6	9.0	11.4	3-2328724-3
31	9.6	10.3	9.65	9.0	8.4	10.8	3-2328724-1
25	7.8	8.5	7.85	7.2	6.6	9.0	2-2328724-5
21	6.6	7.3	6.65	6.0	5.4	7.8	2-2328724-1
15	4.8	5.5	4.85	4.2	3.6	6.0	1-2328724-5
13	4.2	4.9	4.25	3.6	3.0	5.4	1-2328724-3
PIN NO.	DIM.F	DIM.E	DIM.D	DIM.C	DIM.B	DIM.A	PART NO.

THIS DRAWING IS A CONTROLLED DOCUMENT.

DWN Eliana.Zhang 29DEC2017	 TE Connectivity FPC CONNECTOR PITCH=0.30mm FRONT FLIP	
CHK Wenke.He 29DEC2017		
APVD Wenke.He 29DEC2017		
NAME 108-115143		
PRODUCT SPEC 108-115143	SIZE A3	
APPLICATION SPEC -	CAGE CODE -	
WEIGHT SEE TABLE	DRAWING NO C-2328724	
CUSTOMER DRAWING		RESTRICTED TO -
SCALE 10:1		SHEET 1 OF 3
REV 3		

THIS DRAWING IS UNPUBLISHED.

RELEASED FOR PUBLICATION

ALL RIGHTS RESERVED.

© COPYRIGHT - -

REVISIONS

P	LTR	DESCRIPTION	DATE	DWN	APVD
-	-	SEE SHEET 1	-	-	-

RECOMMENDED LAND PATTERN  
(RECOMMENDED METAL MASK THICKNESS:T=0.1mm)

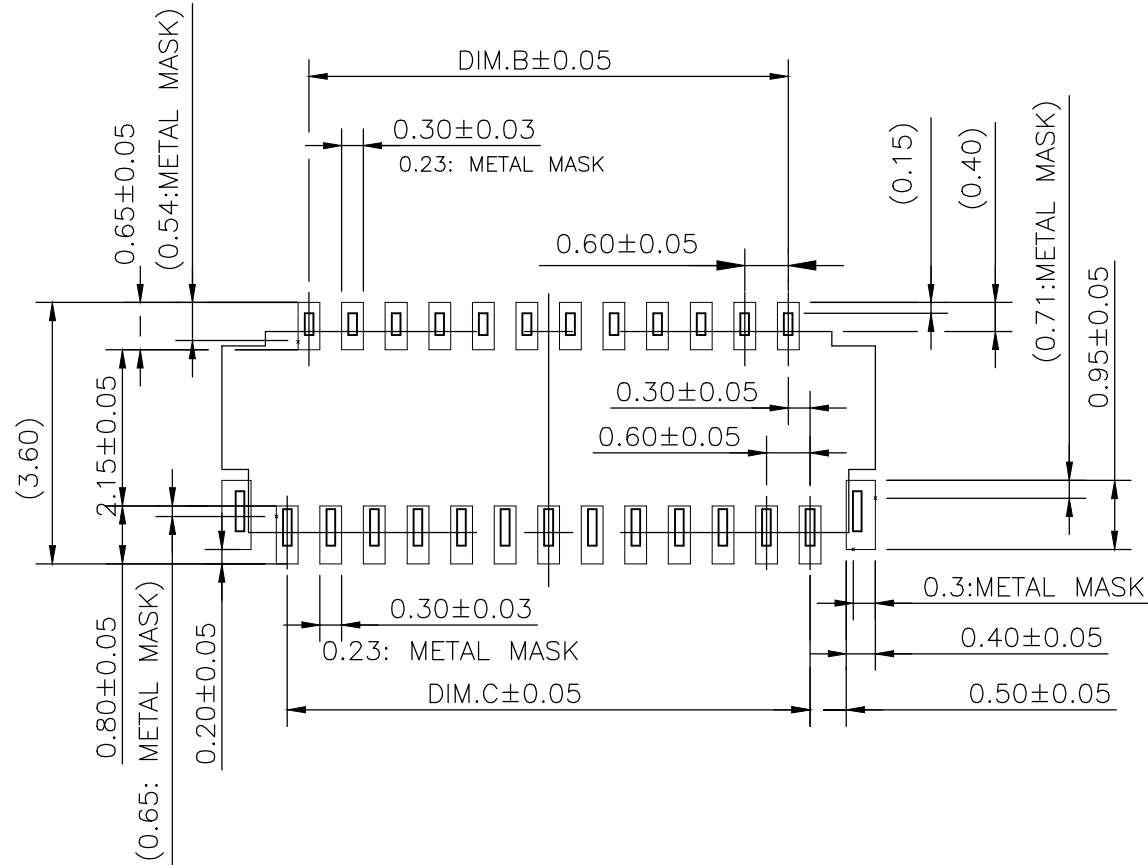

RECOMMENDED FPC

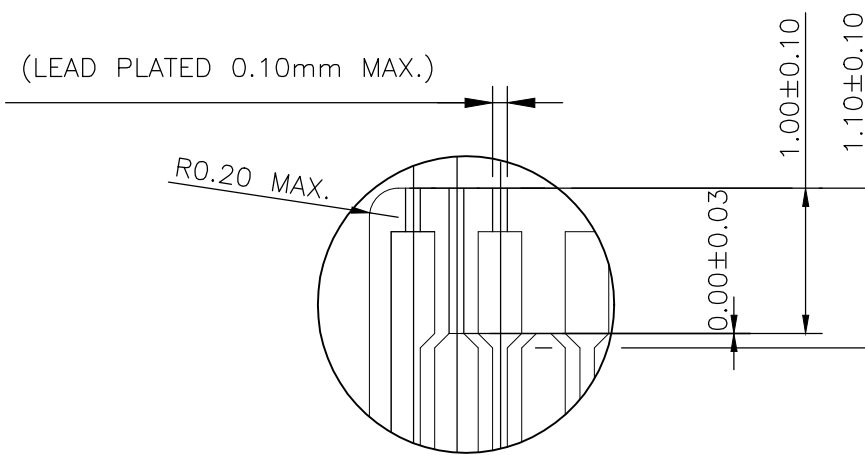
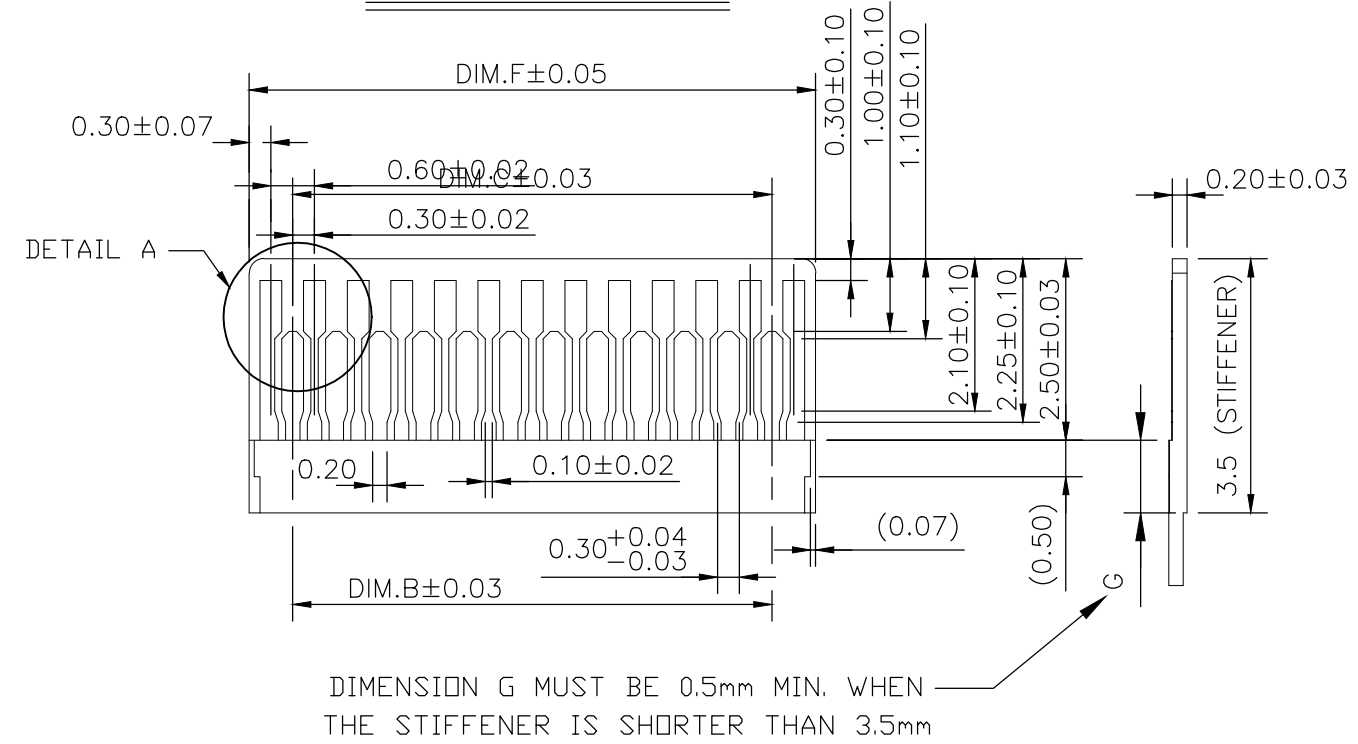

DETAIL A

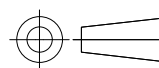
THIS DRAWING IS A CONTROLLED DOCUMENT.		DWN Eliana.Zhang 29DEC2017	 <b>TE Connectivity</b>			
DIMENSIONS: mm		CHK Wenke.He 29DEC2017				
TOLERANCES UNLESS OTHERWISE SPECIFIED:		APVD Wenke.He 29DEC2017	NAME FPC CONNECTOR PITCH=0.30mm FRONT FLIP			
		PRODUCT SPEC 108-115143	RESTRICTED TO			
MATERIAL		FINISH	APPLICATION SPEC	SIZE A3	CAGE CODE -	DRAWING NO C-2328724
-		-	WEIGHT SEE TABLE	SCALE 10:1	SHEET 2 of 3	REV 3
CUSTOMER DRAWING						

THIS DRAWING IS UNPUBLISHED.

RELEASED FOR PUBLICATION

© COPYRIGHT - -

ALL RIGHTS RESERVED.

REVISIONS

P	LTR	DESCRIPTION	DATE	DWN	APVD
-	-	SEE SHEET 1	-	-	-

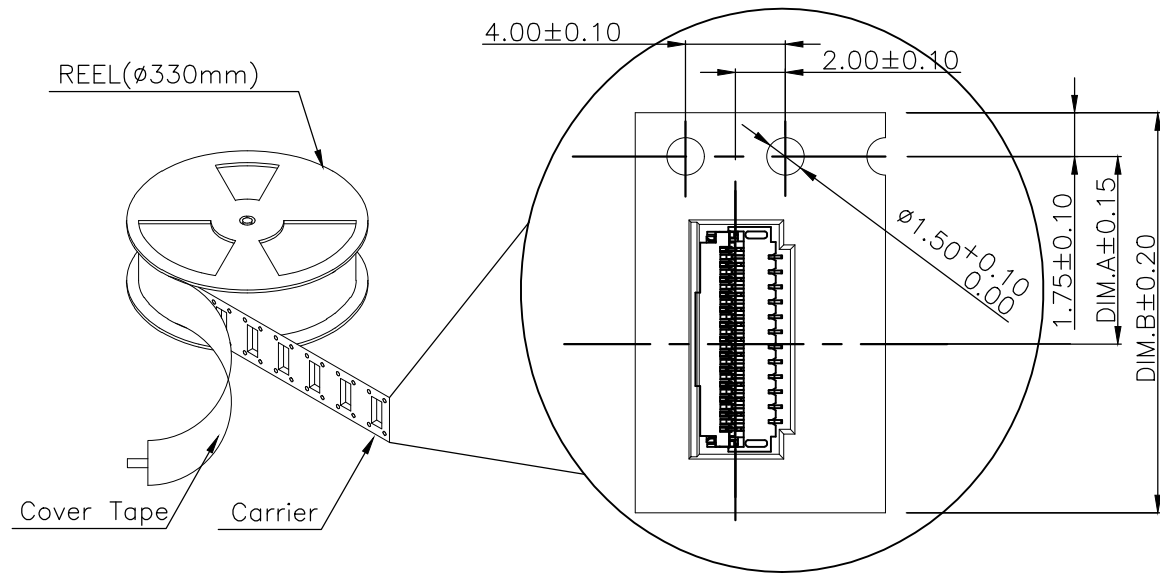

NOTES: (APPLIED TO CURRENT SHEET)

1. THE DIRECTION OF EACH CONNECTOR ON A EMBOSS IS REFERRED TO THIS DRAWING.
2. PACKAGED IN EMBOSS TAPE AND PLASTIC RELL 5000 PCS PER RELL.
3. WINDING THE COVER TAPE AROUND THE OUTER PERIPHERY IN A TURN.

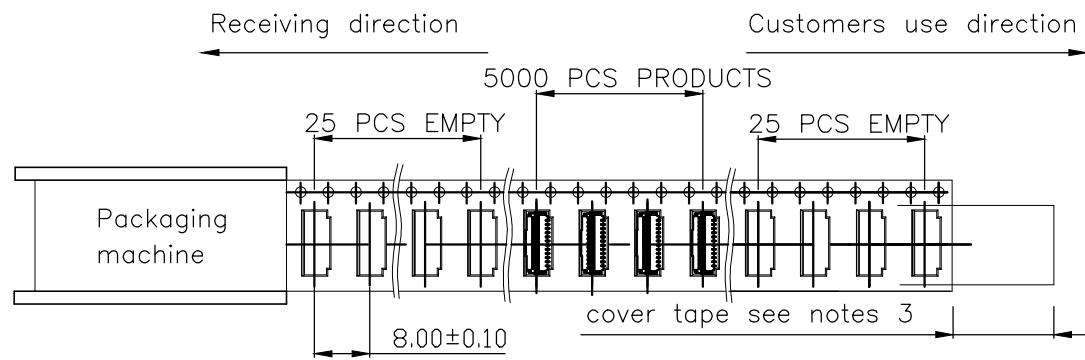
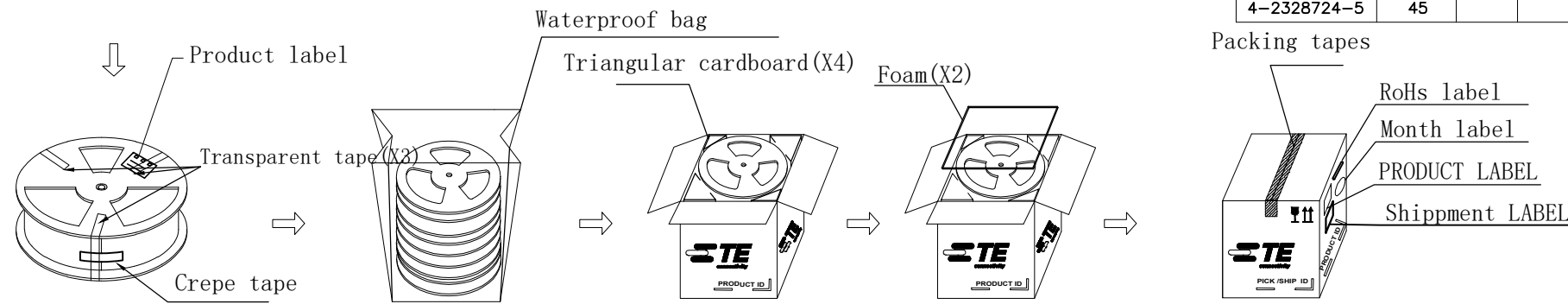

TABLE A

P/N	PIN NO.	Amount of packing				Weight of packing			
		DIM.A	DIM.B	Pcs/Reel	Reel/Carton	PCS/Carton	Unit weigh(g)	Net weight(kg)	GW (kg)
1-2328724-3	13	7.50	16.00	5,000	7	35,000	0.0305	1.068	4.43
1-2328724-5	15			5,000	7	35,000	0.0345	1.208	4.82
2-2328724-1	21			5,000	7	35,000	0.0455	1.593	5.21
2-2328724-5	25	11.50	24.00	5,000	7	35,000	0.0550	1.925	5.48
3-2328724-1	31			5,000	5	25,000	0.0645	1.613	4.99
3-2328724-3	33			5,000	5	25,000	0.0665	1.663	5.08
3-2328724-9	39			5,000	5	25,000	0.0775	1.938	5.37
4-2328724-5	45			5,000	5	25,000	0.0885	2.213	5.64



THIS DRAWING IS A CONTROLLED DOCUMENT.		DWN Eliana.Zhang 29DEC2017	TE Connectivity FPC CONNECTOR PITCH=0.30mm FRONT FLIP		
DIMENSIONS: mm		CHK Wenke.He 29DEC2017			
TOLERANCES UNLESS OTHERWISE SPECIFIED:		APVD Wenke.He 29DEC2017	NAME		
0 PLC ± 0.4 1 PLC ± 0.25 2 PLC ± 0.15 3 PLC ± 0.10 4 PLC ± - ANGLES ± 3.0		PRODUCT SPEC 108-115143	RESTRICTED TO		
MATERIAL		APPLICATION SPEC	SIZE A3	CAGE CODE -	DRAWING NO C-2328724
FINISH		WEIGHT SEE TABLE	SCALE 10:1		SHEET 3 of 3
		CUSTOMER DRAWING	REV 3		



Компания «ЭлектроПласт» предлагает заключение долгосрочных отношений при поставках импортных электронных компонентов на взаимовыгодных условиях!

Наши преимущества:

- Оперативные поставки широкого спектра электронных компонентов отечественного и импортного производства напрямую от производителей и с крупнейших мировых складов;
- Поставка более 17-ти миллионов наименований электронных компонентов;
- Поставка сложных, дефицитных, либо снятых с производства позиций;
- Оперативные сроки поставки под заказ (от 5 рабочих дней);
- Экспресс доставка в любую точку России;
- Техническая поддержка проекта, помощь в подборе аналогов, поставка прототипов;
- Система менеджмента качества сертифицирована по Международному стандарту ISO 9001;
- Лицензия ФСБ на осуществление работ с использованием сведений, составляющих государственную тайну;
- Поставка специализированных компонентов (Xilinx, Altera, Analog Devices, Intersil, Interpoint, Microsemi, Aeroflex, Peregrine, Syfer, Eurofarad, Texas Instrument, Miteq, Cobham, E2V, MA-COM, Hittite, Mini-Circuits, General Dynamics и др.);

Помимо этого, одним из направлений компании «ЭлектроПласт» является направление «Источники питания». Мы предлагаем Вам помощь Конструкторского отдела:

- Подбор оптимального решения, техническое обоснование при выборе компонента;
- Подбор аналогов;
- Консультации по применению компонента;
- Поставка образцов и прототипов;
- Техническая поддержка проекта;
- Защита от снятия компонента с производства.



#### Как с нами связаться

**Телефон:** 8 (812) 309 58 32 (многоканальный)

**Факс:** 8 (812) 320-02-42

**Электронная почта:** [org@eplast1.ru](mailto:org@eplast1.ru)

**Адрес:** 198099, г. Санкт-Петербург, ул. Калинина, дом 2, корпус 4, литера А.